

**Integration of Manufacturing
Resource Planning (MRP II)
Systems With Computer Aided
Design (CAD)**

by

**G. Harhalakis, L. Mark, and M.
Bohse**

Integration of Manufacturing Resource Planning (MRP II)
Systems with Computer Aided Design (CAD)

G. Harhalakis¹, L. Mark², M. Bohse¹

¹University of Maryland, Department of Mechanical Engineering

²University of Maryland, Department of Computer Science

Abstract. The traditional, fragmented approach to increasing manufacturing efficiency has resulted in "islands of automation" in our factories. Computer Integrated Manufacturing (CIM) is the goal of tying together these islands into a single coherent system capable of controlling an entire manufacturing operation. The technical and organizational difficulties of such a massive undertaking require a modular approach to CIM implementation, with an initial nucleus being gradually expanded by allowing interaction between it and other systems' databases. Manufacturing Resource Planning (MRP II) is best positioned to serve as this nucleus. The suggested first system for integration is Computer Aided Design (CAD); the integration being centered around part specification, product structure, and engineering changes.

A model of the CAD/MRP II integrated system, detailing the logical interaction between the systems in the areas of part specification maintenance and engineering changes, is currently being developed and presented. Integration is to be achieved through a multi-database interoperability system, which uses Artificial Intelligence concepts to define and enforce the update and retrieval dependencies of the databases. Finally, the implementation strategy, which requires several stages, is also presented.

INTRODUCTION. Under pressure to remain efficient and competitive, many companies feel compelled to implement one or more of the vast array of new technologies and techniques which are being presented and promoted as a means to the development of the factory of the future. These include Computer Aided Design (CAD), Computer Aided Manufacturing (CAM), Flexible Manufacturing Systems (FMS), Manufacturing Resource Planning (MRP II), Group Technology (GT), Just In Time Inventory Control (JIT), Automated Materials Handling (AMH) and Computer Aided Process Planning (CAPP), to name only a few. Too often, however, this approach, in which individual technologies are implemented independently, results in "islands of automation", where individual tasks are automated without any communication or interfacing with other related activities.

Instead of firms independently automating as many as 50 different functional areas [1] often using unique hardware and software for each, it is time to adopt a systematic approach to implementing and integrating the various technologies as a means for achieving the productivity gains required [2].

The ultimate goal of this implementation and integration process is to attain some form of Computer Integrated Manufacturing (CIM): the appropriate use of both hardware and software to provide effective and economical interaction between every production related activity based on an integrated systems architecture. Superficially, CIM is sometimes defined as the integration of CAD and CAM; to fully justify the term, however, CIM must include all of the techniques mentioned above, and perhaps some others, each of which has a role in the planning, monitoring, control and execution of the various production functions. Each of those techniques is used to enhance and facilitate the tasks involved throughout the life cycle of a typical product: plan, design, develop, manufacture, sell and service. By coordinating all these functions and sharing common data, CIM will improve productivity, delivery performance and overall profitability and competitiveness. In a typical CIM environment, an engineer uses Computer Aided Design to design and draft a product based on the requirements set forth by marketing surveys and research. When the design is finalized, it will be passed to both the Manufacturing Resource Planning system for recording product structure information and the Computer Aided Process Planning system, where, using Artificial Intelligence and Group Technology, process plans will be developed. Once the process plans are complete, these will be downloaded to the routings file of the Manufacturing Resource Planning system for execution at the appropriate time. MRP II coordinates the scheduling of

shop floor activities and machines, and the gathering of materials and other resources (i.e., labor, equipment, cash, etc.), based on the process plans and the production schedule as established by Master Scheduling and detailed by the Material Requirements Planning module. In its execution role, MRP II can be assisted by Artificial Intelligence, Automated Materials Handling, Computer Aided Manufacturing, Group Technology, and other techniques to enhance its capabilities. By coordinating all of these activities, MRP II effectively serves as the "hub" of the CIM system, as depicted in Figure 1, the proposed functional model of CIM. The links between the various systems are determined by the common information required and the logical rules to regulate the data flow.

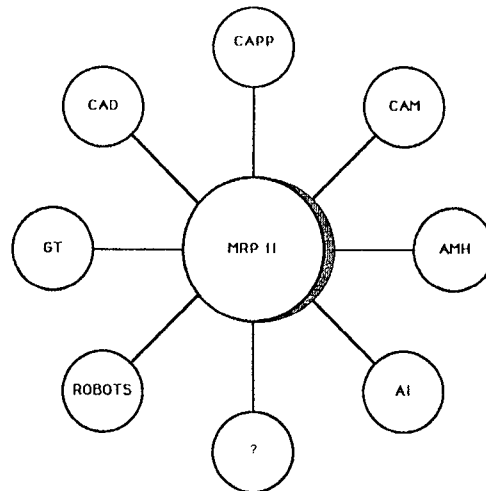

Fig. 1 Functional CIM Model with MRPII as the "Hub"

Today, CIM is only a goal; it cannot be purchased as a turn-key system, and no one has yet created a comprehensive CIM system in industry or academia. The barriers to CIM are numerous and include not only technological difficulties, but organizational issues as well. For CIM to be successful, management will have to take the leadership role in coordinating the gradual implementation and integration of CIM components as

they become available and most importantly, prepare the members of the organization for the drastic changes that will accompany CIM development.

This paper discusses a suggested model for the functional integration of CAD and the Bill of Material module of an MRP II system, given the fundamental similarities of operations and commonality of data between these systems. The functional design and the detailed description of the model are followed by the first steps toward the implementation of it, using the multi-database interoperability technique discussed in later sections. The next steps required to reach a state of functionality follow the conclusions drawn from this first part of the work.

STRATEGIC ISSUES IN THE DATABASE ARCHITECTURE. There are many problems and issues that must be resolved before CIM is possible, among which the database architecture is of utmost importance. Given the functional model of CIM proposed in Figure 1, how is the actual system to be constructed? There are two primary schools of thought in this area. The first is that a single database, accessible to all system functions and maintaining all system data, should be constructed as shown in Figure 2a. The second alternative is that separate databases be maintained for each function, and interoperational capabilities be added as needed. This concept is presented in Figure 2b.

The idea of a single database has some definite advantages over the idea of separate databases. With a single database shared data are stored in one place, whereas with separate databases copies of the shared data may be stored in several of the databases. In a single database the problem of maintaining consistency between several copies of the same data is non-existing. A single database solution would also avoid the overhead associated with communication between the functions in the separate database solution.

It is not clear which of the two solutions would give the users the best response time. With a single database the response time for all functions would be higher because of the size of the database. With separate databases the response time for functions that only affects their local database would be low, whereas the response time for functions that affect other than their local database could be very significant, depending on the amount of traffic (number of inter-database operation calls) needed to maintain consistency.

The separate database solution has some definite advantages too. The single database solution would require CIM to be developed from scratch; a nonmomental task for any single developer. The separate database solution, on the other hand, protects the investments in existing systems. If is not only the investment in actual software that is important here, but education of employees using the software as well.

Furthermore, the separate database solution facilitates a gradual evolution towards CIM, and carries the promise of software vendor independence. We feel that the separate database solution carries sufficient promise to warrant further investigation. As seen later multi-database interoperability depends on artificial intelligence, in the form of rule-based expert systems, in order to define the proper interaction between the databases involved, under all circumstances.

SYSTEM DESCRIPTION. The systems under consideration for this starting point are Computer Aided Design (CAD) and Manufacturing Resource Planning (MRP II). While neither of these can be called fully mature, their overlap is well established: product definition. CAD facilitates the creation and design of parts and assemblies, where assemblies are really just arrangements of component parts. MRP II has the role of cataloging each part and assembly by number and description

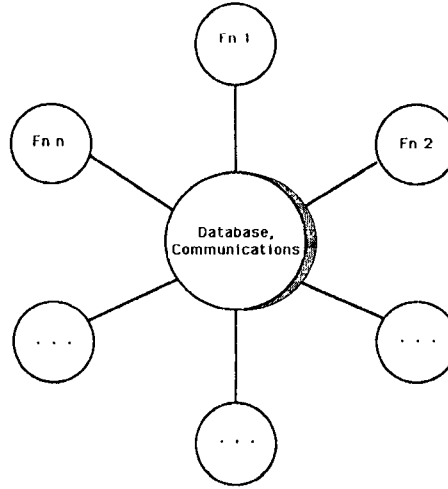

a Single Database Approach to CIM

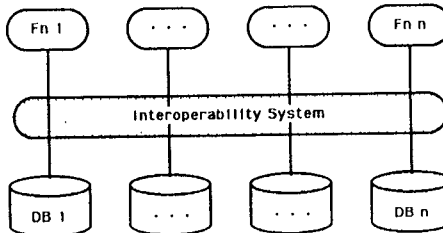

b Multiple Database Approach to CIM
Fig. 2 Single and Multiple Database Concepts

and defining the product structure (i.e. where each part is used).

More specifically, the elements common to MRP II and CAD addressed by the integration are as follows:

- Part Specifications
- Bills of Material
- Engineering Changes

In both systems, part specifications serve to document component parts and assemblies. In MRP II, part specifications are contained in a Part Master Record (PMR) which contains information needed for the procurement, manufacture, or assembly of components, such as:

- Part number
- Drawing number
- Revision level

- Description
- Source code (make or buy)
- Unit of measure
- Vendor information (for purchased parts)
- Leadtime
- Cost

Many, but not all, of these fields are likewise maintained in a CAD system, for the purpose of documenting and cataloging design drawings.

Bills of Material (BOM's) are used to define the product structure of assemblies using a family tree format to relate the component parts to the final product. Parts on a given level in a BOM are said to be the "parent" items of the parts on the next lower level. If structured properly, a BOM serves as a model of the sequence of fabrication and assembly operations for the end product.

Using the BOM and PMR information for a product and its components, MRP II establishes a plan for production activities and material purchases. In the Materials Requirements Planning (MRP) module of MRP II, the requirements for end product manufacture (as input from the Master Scheduling module of MRP II) are carried through the various levels of the BOM to determine the quantity of each assembly, component, and raw material needed, and the requirement date (using the leadtime and vendor information in the PMR). Inventory records are checked for current inventory levels and pending orders to calculate the net requirements of each item. MRP II then initiates the generation of purchase and manufacturing orders for the required purchased and manufactured parts, respectively.

To CAD, the BOM is represented by the parts list associated with each assembly drawing, which is the single-level explosion of an assembly into its component parts. It is the set of CAD bills of materials up to the top level item that define the product structure for the rest of the system.

Before a part drawing is released in a CAD system, it is assigned a part number and given a description. Additionally, other information, such as revision level, estimated cost, and unit of measure, is typically included. This same information is usually manually re-entered into the MRP II system to form the PMR. As it is entered into MRP II, additional information, such as vendor sources and leadtime, is added. The step of re-entering the information into MRP II means both wasted time and a greater chance of errors.

The creation of BOM's is generally similar to that of PMR's. The parts lists from CAD assembly drawings are entered into MRP II manually. Creating BOM's in this fashion for complex assemblies is very time consuming, as repeated reviews of drawings are essential to assure accuracy. As with PMR creations, the re-entry of similar data requires extra time and results in more errors.

Even when newly released, there is a chance of inconsistent part or product structure data between CAD and MRP II. To make matters worse, engineering changes, which are inevitable throughout a product's life cycle, must also be entered and maintained in each system independently. Thus the chance of inconsistency increases as the part ages.

The extra effort and higher error rate caused by maintaining PMR and BOM data in both CAD and MRP II can be eliminated. Common data can be maintained and made available to either system, eliminating transcription errors resulting from keying the same data into both. Part specifications information from CAD drawings would be transferred to MRP II at the time of the drawing's release to establish a skeletal Part Master Record, which could be completed by MRP II users. For assembly drawings, a first cut BOM would likewise be transferred

to MRP II using information in the parts list. The BOM could then be modified by MRP II users to better represent the manufacturing sequence.

Engineering changes would be greatly simplified by the integrated system. Parts requiring modifications for safety reasons could be pulled from use by users of either system. As soon as new revisions of parts or replacement parts are released by CAD, the data is available to MRP for planning purposes.

THE FUNCTIONAL DESIGN OF THE MODEL. The functional model of the CAD/MRP II integrated system is based on the similarity of functions and the commonality of data between the two systems. The model is not derived from any two commercial packages in particular, but instead is intended to be generic enough to be applied to any set of fairly well-designed systems. The model to be presented includes the sharing of part specification and engineering change data. The model is intended to operate in a discrete parts, make-to-stock environment.

The part specification data maintained by each system is shown in Figure 3. General part data is maintained for each part and is retrieved by part number; in addition to this data, the effectivity start and end dates and status code (different for each system) of each revision is maintained.

For Each Part Number	
CAD	MRP II
Part Number	Part Number
Drawing Number	Drawing Number
Drawing Size	Drawing Size
Description	Description
CAD Unit of Measure	CAD(BOM) Unit of Measure
	MRP(Purchasing) Unit of Measure
	UOM Conversion Factor
	Source Code
	Cost
	Leadtime
Supersedes Part Number	Supersedes Part Number
Superseded by Part Number	Superseded by Part Number
For Each Revision Level	
CAD	MRP II
Part Number	Part Number
Revision Level	Revision Level
Effectivity Start Date	Effectivity Start Date
Effectivity End Date	Effectivity End Date
CAD Status Code	MRP II Status Code

Fig. 3 Part Specification Data Maintained by Each System

It is assumed that no data exists in either system when the integration is established, ensuring data consistency.

The functioning of the model can be represented by examining the status codes associated with each part and revision. These codes have different values for each system, as follows:

CAD Status

- W - "Working", not a completed drawing, used prior to approval, and not transmittable to MRP II
- R - "Released", an active part
- H - "Hold", under review, pending for approval, possibly with a new revision level. Part should not be used by either system.

0 - "Obsolete"

MRP II Status

R - "Released", active part

H - "Hold", not to be used by MRP

The basic functions of the system are described with the aid of status code diagrams, showing the flow of information and the status of each part in both systems during a given activity. In the following sections, the basic operations are described through the presentation of appropriate scenarios.

Creation of New Part

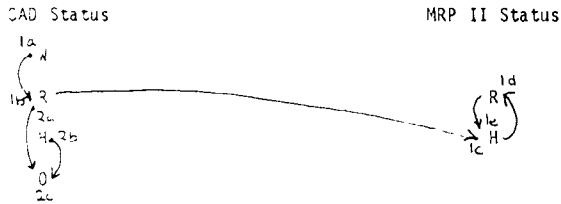

Fig. 4 Status Diagram for the Creation of a New Part

A brand new part is first created by a CAD user as a working drawing (figure 4, point a). At this point, no information about the part exists in MRP II. Upon completion and approval within CAD, the part is released by a CAD user (b).

If the part supersedes another, the status of the superseded part is immediately changed in CAD to obsolete, (2c), regardless of whether the part previously had an R status (2a) or an H status (2b). In MRP II, the changeover to the superseding part is performed automatically, by virtue of the effectivity start date of the higher level assembly calling for the new part as part of a revision change, handled by an Engineering Change Procedure.

The release of the new part within CAD triggers the establishment of a skeletal Part Master Record (PMR) in MRP using the CAD Part Specification data. Because the PMR is not complete, and to give manufacturing time to plan for the purchase or manufacture of the part (eg., search for vendors, develop routings) the part is given a status of H in MRP II (c). When MRP II users complete the PMR, the part can be released within MRP II (d). If the need arises, due to a machine break down or vendor problems, for example, MRP II users can place a local hold on the part (e) without affecting CAD. Once held, MRP II users can again release the part.

There are three cases involving the submission for a revision change. Each begins in the above diagram with the old revision having a released status in both CAD and MRP II. (point a, Figure 5a).

The first case (indicated by "1" preceding the letters in the status diagram) occurs when CAD is notified by MRP II users of a desire for a change in a part. If the CAD users decide the part is adequate as is, there is no change of status within CAD. MRP II users may invoke a local hold during the review (1b), but this has no effect on CAD.

The second case (2 in Fig. 5a) involves CAD users putting the part on hold within CAD to review the design (2b). Because safety concerns may be the reason for the design review, a hold placed on a part in CAD automatically triggers a hold on the part in MRP II (2c) (if the part wasn't put on hold by MRP II users already). In this scenario, the CAD users determine the part to be satisfactory, and re-release it without change (2d). A message is then sent to MRP II to

notify its users of the re-release; the part remains on hold in MRP II, however, until released by that systems users (2e).

The final case occurs when CAD users determine that

Submission of Parts for Revision Change

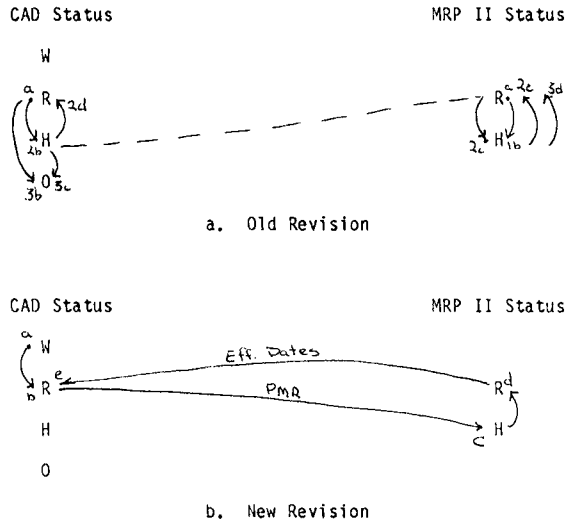

Fig. 5 Status Diagrams for the Submission of Parts for a Revision Change

a new revision is necessary. The new revision is created as a working drawing (point a, Fig. 5b). When the new revision is released by CAD (b), the status of the old revision in CAD is changed to "0", whether its status was previously "R" (3b) or "H" (3c). In addition, any changes to the part data are communicated to MRP II (c, new revision diagram) along with a record of the new revision, which is given an "H" status for the same reasons given for new parts. MRP II users are also responsible for determining the effectivity start date of the new revision, since they have access to inventory and quantity-on-order information. On release by MRP II users, the effectivity date is sent back to CAD (e) and recorded in the part data for informational purposes. Note that since MRP II automatically determines which revision of a part to select based on the effectivity dates, there is no need for an explicit "obsolete" status as used in CAD. After the release of the new revision, MRP II users can re-release the old revision (3d) to use it until the effectivity start date of the new revision.

Obsolescence of a Part

Parts may be made obsolete in CAD from either "R" or "H" CAD status, since the obsolescence may be due to a routine phasing out or due to safety or performance problems. For routine phasing out, there is no need for an intermediate hold in CAD, (which would automatically cause a hold in MRP II as well). A message is simply to be sent to MRP II, but the part's status is not to be changed, allowing the use of existing inventory and orders. For safety or performance related problems, a hold in CAD may be used prior to obsolescence to ensure that the part is not used by MRP II.

Deletion of a Part

Deletion of a part may be initiated by either CAD or MRP II users. Before the deletion can be completed, MRP II is checked to determine if the part to be deleted is used in a product structure, has a non-zero inventory level, or has any outstanding orders. If any of these are found to be true, the deletion is not pro-

passed. If none of these are true, the deletion occurs: within MRP II, all of the part data is deleted; within CAD, the part is made obsolete, but the data maintained for historical purposes and possible future use.

To accomplish each of these scenarios, the processes are broken down into simple tasks such as the creation of a working CAD drawing or placing a CAD hold. Each of these tasks, or operations, is to be programmed separately, allowing for maximum flexibility. A sample flow chart, representing the release of a working part drawing from CAD and the establishment of a PMR in MRP II, is shown in Figure 6.

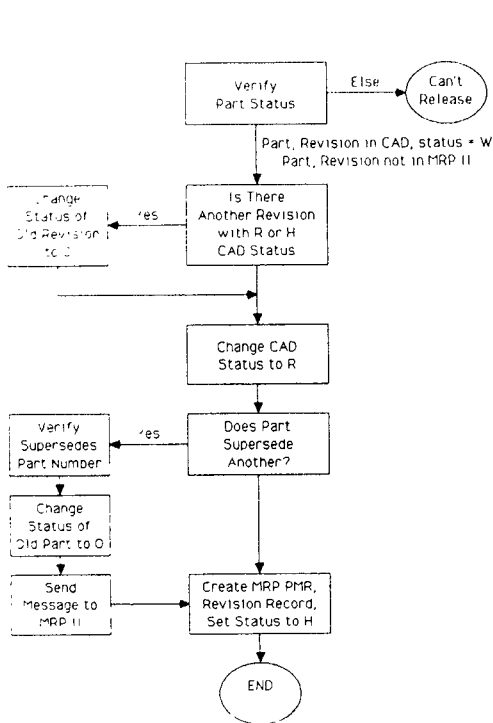

Fig. 6 Flowchart for the Release of a Working Part from CAD

Summarizing the functional characteristics, the CAD system is positioned as the focus of product design and engineering changes. Drawings and part specifications, for both new parts and new revisions, are initiated by CAD, and CAD users are given the ability to place parts on hold throughout the combined system if the need arises. MRP II users are responsible for the planning and manufacture of parts, completing the skeletal CAD part data, and establishing effectivity dates for engineering changes.

MULTI DATABASE INTEROPERABILITY. It was the need for simultaneous access to and manipulation of independently created and managed data files and the need to keep these data files mutually consistent that spurred the database research in the late 1960's and early 1970's.

Because the problems then and now are very similar, most attempts to integrate independently created and managed databases have reapplied the database approach.

The database approach is based on centralized control and integration, and common to these previous attempts is therefore the notion of a global schema, integrating the schemata of the existing databases.

There are basically two ways to integrate existing databases using a global schema. The global schema can be placed between the databases and the system. In this case, the schemata of the existing databases become external schemata and the application software can be preserved, but the data must be reorganized and stored under the global schema. This is illustrated in Figure 7. Alternatively, the global schema can be placed between the users and the databases. In this case, the application software must be rewritten, but the data need not be reorganized. This is illustrated in Figure 8.

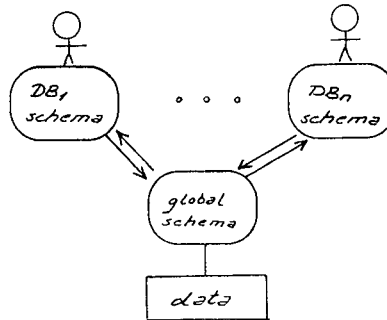

Fig. 7 A Global Schema between the Databases and the System

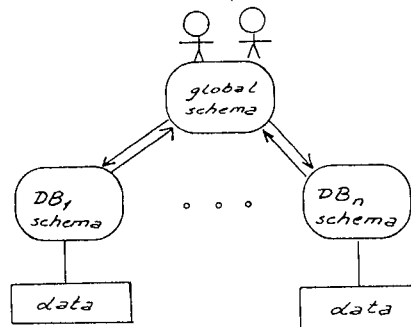

Fig. 8 A Global Schema Between the Users and the Databases

The basic problem in database integration is the required initial design of a global schema which is the UNION of the schemata of the databases to be integrated.

If the databases to be integrated are HOMOGENEOUS, i.e. their schemata are all defined in terms of the same data model, then one encounters the following:

easy problems:

- domains may have different physical representation, e.g. integer or real;
- domains may have different units of measure, e.g. inches and centimeters;
- domains may have different structure, e.g. date may be mmddyy or ddmmyy;
- domains that represent the same may have different names;
- records that represent the same may have different names;

difficult problems:

- the same fact is modeled by different record structures;
- different constraints apply to the same fact;

very difficult problems:

- conflicting models of similar facts;
- conflicting constraints apply to similar facts

If the databases to be integrated are HETEROGENEOUS, i.e. their schemata are defined in terms of different data models, then one encounters

very difficult problems:

- define mappings between data structures in different data models, and
- define mappings between DMLs of different data models

It is noted that it is not the notion of a global schema as such that gives problems in database integration. The problems stem from the requirement, that the global schema be designed from the very outset of the integration; and worse, that the global schema is thought of as the UNION - without redundancy and internal conflicts - of the schemata of the existing databases. This situation is illustrated in Figure 9.

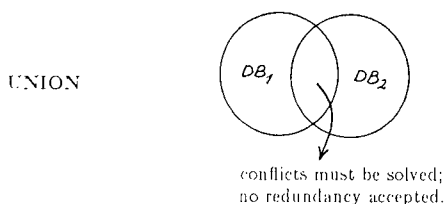

Fig. 9 Database Integration

Let us distinguish the proposed notion of database interoperability from the previous notion of database integration by the illustration in Figure 10.

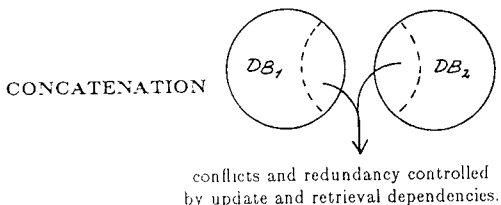

Fig. 10 Database Interoperability

The basic idea is to let the initial global schema be the CONCATENATION of the schemata of the existing databases. The global schema still in other words initially consist of all the schemata of the existing databases with all the redundancy and all the conflicts this implies.

In addition a rule-set is constructed for each separate database called update and retrieval dependencies, which controls inter-database consistency through interdatabase operation calls. This rule set enforces the functionality of the integrated MRP II and CAD systems as described earlier.

It is assumed that all the databases are defined in terms of one family.

A relation R is update dependent on relation S if there exists an update on relation R that succeeds only if one or more implied updates on relation S succeed.

A relation R is retrieval dependent on relation S if there exists a retrieval from relation R that succeeds only if one or more implied retrievals from relation S succeed.

Update and retrieval dependencies have the following (example) structure:

```

op1(R) → cond;
           op2(S);
           op3(T);
           op4(R).
    
```

The meaning is as follows: operation op₁ on relation R is said to succeed if and only if the condition, "cond", evaluates to true and the operation op₂ on S and the operation op₃ on T and the operation op₄ on R all succeed. The operations on the right-hand side may be primitive operations or they may themselves be specified as above.

The relations R, S, and T may reside in the same database or in different databases.

If all the relations reside in the same database, then the update dependencies merely give an operational specification of a set of constraints in that database. If, on the other hand, the relations reside in different databases, then the update dependencies give an operational specification of a set of inter-database constraints. Figure 11 displays sample update dependencies on relations in two databases.

There are two alternative architectures for Multi-Database Systems based on interoperability:

- loosely coupled systems, and
- tightly coupled systems.

In a loosely coupled system the update dependencies would be specified in the individual database schemata. In a tightly coupled system the update dependencies would be specified in a special schema under centralized control.

The loosely coupled architecture is currently adopted which seems to fit best with the proposed evolutionary approach.

Communication in a loosely coupled system is established through inter-database operation calls. The only data passed between databases are the actual parameters of the operation calls. Finally, messages about the success or failure of an operation are passed from the site where the operation was executed to the site where the call of it originated. If retrieval operations are considered, then the data resulting from a retrieval operation has to be communicated back to the site where the call of it originated. As an important part of the research on Multi-Database Interoperability a communication protocol must be defined.

The model for Multi-Database Interoperability allows one to consider a given set of databases as a Multi-Database. But, Interoperability is not established until update and retrieval dependencies are defined in the database schema.

Establishing Interoperability is a continuous evolution process. At the beginning of this process the user will see no change in the database. Gradually, as more retrieval dependencies are added to the schema of the database, the user will be able to see more of the multi-database. Gradually, as more update dependencies are added to the schema of the database, the

Example

CAD database:

```

create_drawing_id(P,D,U,R)
drawing_id(P,D,U,R).
create_part_master(P,D,U,R).
assert_drawing_id(P,D,U,R).
drawing_id(P,D,U,R).
write("Drawing already exists for",P).

```

MRP database:

```

create_part_master(P,D,U,R)
part_master(P,D,U,R).
write("what is the lead time for",P).
break, read L.
write("what is the cost of",P).
break, read C.
assert_part_master(P,D,U,R).
(*check inventory module*)
(*call operations on purchasing module*)
part_master(P,D,U,R).
write("P already exists in part_master").
fail

```

CAD and MRP II systems under the control of one instance of the interpreter.

The third step is to integrate a remote procedure call facility into the interpreter. This will allow for running functional copies of the MRP II and the CAD system under separate instances of the interpreter on the same machine.

The fourth step is to move the two interpreters to different machines by generalizing the remote procedure call facility to allow calls over the net. The execution of steps three and four should not necessarily imply any changes to the functional design of the system.

Whereas this implementation strategy caters for a thorough testing of the specification of the functional relationships between the two systems, it does not provide an integration of two actual systems.

One possible way to not only integrate two actual systems, but furthermore enhance the consistency of each individual system, is to replace the operations in the systems by calls to the interpreters which would then issue and control implied operations on both systems through other system calls.

CONCLUSIONS. The need for manufacturing systems integration has resulted in a CIM crusade in which several industrial and academic researchers are involved. This work suggests a staged approach, starting with MRP II as the nucleus of the system and CAD as the first "satellite". The similarity of functions dealing with the product definition and administration and the large degree of data commonality between BOM of MRP II and CAD call for an attempt to streamline the operations in both systems.

The generation and maintenance of part master records and product structures initiated in the product engineering/design division of every manufacturing organization can be significantly facilitated if an interface is designed and implemented between CAD and MRP II as described in this paper. The functional design of the model must be extended to cover the transition of single level product structures to MRP II, as soon as assembly drawings are completed and released from CAD.

The implementation of the model has just started by translating the logical rules into update dependencies, using a form of rule-based expert systems. On completion of the programming phase, the system will be tested for inconsistencies. Approval of the logical rules will be sought from industrial experts to ensure the applicability of the model in a real working environment.

Subsequently, the model will be extended over two databases on the same computer and later on two computers using remote operation calls.

Future plans include the coupling of Computer Aided Process Planning (CAPP) with the routings module of MRP II for automated downloading of the optimal sequence of manufacturing operations and specification of equipment, tools, jigs and fixtures.

Acknowledgements

The National Science Foundation is acknowledged for partial funding of this work. (Grant No. DMC-85-04922) and the Systems Research Center of the University of Maryland for funding the database interoperability part of this research.

References

1. "The State of CIM", Daniels Appleton, *Datamation*, Vol. 30, pp 66-72. (1984)

Fig. 11 Example of Update Dependencies Specified for Two Databases

effects of the operations on the database can be seen by other users on their databases.

This model for Multi-database Interoperability does not make the very difficult problem of conflicting models of similar facts disappear. No model does! The proposed model does however allow the problem to be solved gradually. Conflicts between models of similar facts can only be resolved or controlled through rigid logical rules as agreed and stated in the functional design of the system.

THE IMPLEMENTATION STRATEGY. The implementation strategy has been planned to allow one to test the specifications of the functional relationships between the MRP II and the CAD systems early in the project.

The first step has therefore been to define a formal language for specifying these functional relationships. This language allows one to specify the operations within and between the MRP II and the CAD systems as an AI production system. This language is currently being evaluated.

The second step is to implement an interpreter for the specification language. The interpreter is being implemented in PROLOG. It is planned to test the specification of the functional relationship between the

2. "The Engineering Research Centers as a Tool for Change in the Culture and Attitudes of Academic Engineering", David C. Hazen, Presentation at the Second Meeting of the Steering Group on Systems Aspects of Cross Disciplinary Engineering, August 3, 1985.