

## ABSTRACT

Title of Thesis: AN ARTS COMMUNITY FOR THE LOGAN CIRCLE  
NEIGHBORHOOD IN WASHINGTON, D.C.

Susan Elizabeth Gibson, Master of Architecture, 2004

Thesis directed by: Steven W. Hurtt, Dean,  
School of Architecture, Planning, and Preservation

In the early 1900's, 14<sup>th</sup> Street in Washington, D.C. was a prominent commercial corridor and the site of numerous automobile showrooms. The riots following Martin Luther King, Jr.'s assassination in 1968 left many damaged buildings and vacant lots along the corridor. This project will seek to revitalize the area. Retail and mixed uses catering to the artist and appealing to the general public will be implemented on the 1500 block of 14<sup>th</sup> Street. An art center located within the block will incorporate affordable, flexible units with spaces for artists to live and work. Galleries and cafes along the ground floor of the building will reach out to the community as a whole.

An artists' community will help redefine 14<sup>th</sup> Street as a 'place.' The development will seek to provide a sense of community within the larger context of the city while acting as a catalyst for future artistic growth.

AN ARTS COMMUNITY FOR THE LOGAN CIRCLE NEIGHBORHOOD IN  
WASHINGTON, D.C.

By

Susan Elizabeth Gibson

Thesis submitted to the Faculty of the Graduate School of the  
University of Maryland, College Park in partial fulfillment  
of the requirements for the degree of  
Master of Architecture  
2004

Advisory Committee:

Dean Steven W. Hurtt, Chair  
Assistant Professor Angel David Nieves  
Professor Thomas L. Schumacher

## **DEDICATION**

To my parents, Elaine and Paul Gibson, for always believing in me.

To my sisters, Cindy and Robin, for always being there for me.

To Adrian Mentus for your love and patience these past two years.

## ACKNOWLEDGEMENTS

Thanks to the following individuals who assisted me through this final charette:

Adrian Mentus  
Laura DeHart  
Elisa Garcia  
John Oderda  
Brad Reed  
Mike Talbott  
Vanessa Vap  
Traci Weems  
Sarah Weiser

A special thank you to Gretchen Wagner for inspiring me this semester, and for your devotion these past weeks.

## TABLE OF CONTENTS

LIST OF FIGURES.....	vi
INTRODUCTION.....	1
CHAPTER I: THE SITE.....	3
Site History.....	3
Site Description.....	15
Site Analysis.....	23
CHAPTER II: PRECEDENT STUDIES.....	39
Arts Districts	
Gateway Arts District (upcoming Arts District).....	39
Short North, Ohio (existing Arts District).....	41
Artists Studios/Galleries	
Torpedo Factory Art Center.....	44
Viaduct des Artes.....	47
Housing	
Fukuoka Housing.....	51
Mount Rainer Artists Housing.....	55
CHAPTER III: Theory.....	58
CHAPTER V: Program.....	63
Design Objectives.....	63
Private Program Requirements.....	64
Public Program Requirements.....	65
Urban Requirements for Block.....	65

CHAPTER VI: SCHEMATIC DESIGNS.....	67
Parti One.....	67
Parti Two.....	69
Parti Three.....	71
Schematic Building Sections.....	73
CHAPTER VII: DESIGN CONCLUSIONS.....	74
BIBLIOGRAPHY.....	84

## LIST OF FIGURES

Figure 1: L’Enfant’s Plan for Washington, D.C. [LCAA website].....	3
Figure 2: Comparison of Versailles, Washington D.C., and Paris. [Peets 46].....	3
Figure 3: 10-mile square of Washington D.C. [Peets 4].....	4
Figure 4: Topography of Washington, D.C. [Peets].....	5
Figure 5: Nodes within plan of Washington, D.C. [Peets].....	5
Figure 6: Vistas to Virginia, across the Potomac River. [Peets].....	5
Figure 7: Bird’s Eye View of McMillan Plan, 1901-1903. [Garvin 78].....	7
Figure 8: Statue @ Logan Circle. [LCCA Website].....	8
Figure 9: 14 <sup>th</sup> Street streetcar, 1870’s. [LCCA Website].....	9
Figure 10: Fourteenth Street. [Greater 14 <sup>th</sup> St & Logan Circle Brochure].....	10
Figure 11: Cars on 14 <sup>th</sup> Street, 1930. [LCCA Website].....	11
Figure 12: DeSoto-Plymouth Dealership on 14 <sup>th</sup> Street, 1935. [LCCA Website].....	11
Figure 13: 1526 14 <sup>th</sup> Street in 1925. [Greater 14 <sup>th</sup> St & Logan Circle Brochure].....	12
Figure 14: 1526 14 <sup>th</sup> Street in 2003.....	12
Figure 15: Image of 14 <sup>th</sup> Street after 1968 Riots. [Redevelopment Land Agency Document 15].....	12
Figure 16: Map of Citywide Damage.....	13
Figure 17: Greater Fourteenth Street and Logan Circle Historic Districts [Greater 14 <sup>th</sup> Street and Logan Circle Brochure].....	14
Figure 18: Aerial Photo, including Thesis Site. [D.C. Office of Planning].....	15
Figure 19: Plan Highlighting Western Side of 14 <sup>th</sup> Street.....	16
Figure 20: Western Side of 14 <sup>th</sup> Street.....	16
Figure 21: Western Side of 14 <sup>th</sup> Street, cont.....	16
Figure 22: Plan Highlighting Eastern Side of 14 <sup>th</sup> Street.....	17
Figure 23: Eastern Side of 14 <sup>th</sup> Street .....	17
Figure 24: Eastern Side of 14 <sup>th</sup> Street , cont.....	17
Figure 25: Plan Highlighting Church Street.....	18
Figure 26: Vacant lot on Church Street .....	18
Figure 27: Development @ Church Street and 14 <sup>th</sup> Street.....	18
Figure 28: Perspective looking down Church Street.....	18
Figure 29: Automobile Repair Shop on Church Street.....	18
Figure 30: Plan highlighting location of the Studio Theatre.....	19
Figure 31: Interior Renovations, 1997. [Kfoury Website].....	19
Figure 32: Exterior of the Studio Theatre.....	19
Figure 33: Plan highlighting location of Studio Theatre Expansion.....	20
Figure 34: Existing Studio Theater and Two Adjacent Buildings.....	21
Figure 35: Studio Theatre Expansion. [Metropolis Development].....	21
Figure 36: Location of Whole Foods Market.....	22
Figure 37: Entrance of Whole Foods Market.....	22
Figure 38: Outdoor Seating at Whole Foods Market.....	22
Figure 39: Exterior of Whole Foods Market.....	22
Figure 40: Regional Diagram of Site and Context.....	23
Figure 41: Map of the Metrorail System.....	24

Figure 42: Diagram of walk from Dupont Circle Metro Station to the site, approximately .55 miles.....	25
Figure 43: Lush landscaping typical of P Street (between Dupont and Logan Circles).....	25
Figure 44: Row homes characteristic of P Street (between Dupont and Logan Circles) Higher density housing occurs as well.....	25
Figure 45: Map of bus lines running through and around the site.....	26
Figure 46: Figure Ground of Site and Greater Context.....	27
Figure 47: Figure Ground Reversal of Site and Greater Context.....	28
Figure 48: Five-minute walk diagram from the site.....	29
Figure 49: Five minute walk from nodes close to site (nodes from L to R: Dupont Circle, Scott Circle, and Logan Circle).....	30
Figure 50: Figure Ground of site and immediate context.....	31
Figure 51: Figure Ground Reversal of Site and Immediate Context.....	32
Figure 52: Diagram of Street Network.....	34
Figure 53: Diagram of Traffic Conditions Near Site.....	35
Figure 54: Retail/restaurant and residential uses near the site.....	35
Figure 55: Civic buildings and churches near the site.....	35
Figure 56: Art/performance spaces and vacancies near the site.....	36
Figure 57: Uptown-Mixed Use (ARTS) Overlay District.....	37
Figure 58: Map of Gateway Arts District. [Gateway Arts District Sector Plan and Sectional Map Amendment].....	39
Figure 59: Map of Short North, arts corridor is highlighted.....	42
Figure 60: Goodale Park. [Short North Website].....	43
Figure 61: Pocket Park. [Short North Website].....	43
Figure 62: Street performers are popular in Short North. [Short North Gazette Website].....	43
Figure 63: Crowds at Gallery Hop. [Short North Gazette Website].....	43
Figure 64: Arches on High Street. [Short North Gazette Website].....	43
Figure 65: Target Gallery, national exhibition space. [Torpedo Factory Website].....	44
Figure 66: Sculptural Stairs in Torpedo Factory.....	44
Figure 67: Diagram of Entrances.....	45
Figure 68: Eastern Entry- Plaza on Potomac.....	45
Figure 69: Western Entry- N. Union Street.....	45
Figure 70: Plan of Torpedo Factory.....	45
Figure 71: First and Second Floor Atrium Space.....	46
Figure 72: Third Floor Studios.....	46
Figure 73: Section through Torpedo Factory.....	46
Figure 74: Map of 12 <sup>th</sup> Arrondissement showing location of Viaduct de Artes.....	47
Figure 75: Railroad viaduct with garden on top. [Amelar 138].....	47
Figure 76: Isometric, Part of the Viaduct. [Viaduc 75].....	48
Figure 77: Drawing of standard arch on viaduct. [Viaduc 75].....	49
Figure 78: Photo of storefront, showing setbacks of glass. [Amelar 141].....	49
Figure 79: Artist working within vaulted space; note daylight pouring in transoms. [Amelar 142].....	50
Figure 80: Section and floor plans of vaulted interiors.....	50

Figure 81: Model of South (Private) Façade. [Holl 99].....	51
Figure 82: Model of North (Public) Façade. Note that courtyard starts at the second level on public side. [Holl 99].....	51
Figure 83: View of North façade [Holl 95].....	51
Figure 84: Diagrammatic Plan showing 3 passages through building.....	52
Figure 85: Diagrammatic Section showing 3 passages through building.....	52
Figure 86: Interlock of Unit Types [Author’s drawing, based on Holl 106].....	52
Figure 87: 3 different configurations of one unit plan (2 sets). [Author’s drawing, based on Holl 06].....	53
Figure 88: Interior of Unit, Configured with panels open. [Holl 107].....	54
Figure 89: Interior of Unit, Configured with panels closed. [Holl 107].....	54
Figure 90: Interior of Unit, Configured with panels open. [Holl 106].....	54
Figure 91: Interior of Unit, Configured with panels closed. [Holl 106].....	54
Figure 92: Exterior model of building. [HGA Website].....	55
Figure 93: Schematic Section through building. [Courtesy HGA].....	55
Figure 94: Section – Public Side.....	56
Figure 95: Interior of Unit. [HGA Website].....	56
Figure 96: Plan Detail – Public Side.....	56
Figure 97: Partial Elevation - Public Side.....	56
Figure 98: Study of programmable wall elements within units.....	57
Figure 99: View from roof of arch.....	59
Figure 100: View to arch.....	59
Figure 101: Artist drawing fountain @ Dupont Circle. [D.C. Stock Photos].....	59
Figure 102: City street of Madrid.....	60
Figure 103: Artists and pedestrians in the Place de la Terte.....	61
Figure 104: Views of Las Ramblas (L to R: Street Performer, Pedestrian Promenade, Street Performer).....	62
Figure 105: Plan of Pocket Park Parti.....	67
Figure 106: Diagram of Pocket Park Parti.....	68
Figure 107: Plan of Promenade Parti.....	69
Figure 108: Diagram of Promenade Parti.....	70
Figure 109: Section through Church Street.....	70
Figure 110: Plan of ‘Catwalk’ Parti.....	71
Figure 111: Diagram of ‘Catwalk’ Parti.....	71
Figure 112: Section through Catwalk @ Café.....	72
Figure 113: Section through Catwalk @ Automobile Museum.....	72
Figure 114: Section showing interaction of gallery space with mezzanine above.....	73
Figure 115: Section showing the two faces of art production: gallery space on the public side, with studio and production space along the alley.....	73
Figure 116: Building section showing opportunity of creating a setback.....	73
Figure 117: Section through entire building, including the 2 existing automobile showrooms on site.....	75
Figure 118: Cross-section showing relationship of building to 14 <sup>th</sup> Street and the roof garden.....	75
Figure 119: First floor plan.....	76
Figure 120: Second floor plan.....	76

Figure 121:	Third floor plan.....	77
Figure 122:	Plan of floor 3 ½ (see Figure 116 for floor relationships).....	77
Figure 123:	Fourth floor plan.....	78
Figure 124:	Fifth floor plan.....	78
Figure 125:	Unit plans.....	79
Figure 126:	West elevation with context.....	80
Figure 127:	West elevation.....	80
Figure 128:	North elevation with context.....	81
Figure 129:	North elevation.....	81
Figure 130:	Perspective of Gallery/Café (Northwest corner).....	82
Figure 131:	Perspective of main gallery.....	83

## INTRODUCTION

Throughout its history, the Greater 14th Street District in Washington D.C. has been an area of great economic and social diversity. In the 1800's and 1900's, residents living within the neighborhood were from various economic backgrounds, with the wealthier living along the major thoroughfares and the working class living on side streets and alleys.

Fourteenth Street was a major commercial corridor during the 1870's and 1880's. In the early 1900's the popularity of the automobile continued to make the street a popular destination. During this time, automobile showrooms arose along the corridor, making 14<sup>th</sup> Street a hub of automobile exhibition and activity.

The activity following the assassination of Martin Luther King, on April 4, 1968, brought the area into a major state of decline. Riots along the commercial corridor left many buildings in flames, resulting in numerous abandoned buildings and vacant lots. Currently, the area is in need of major revitalization, as most of the damage is still evident today.

Arts Districts have been linked with the revitalization of communities across the United States. Short North in Columbus, Broad Street in Philadelphia, and the Addison Street Arts District in Berkeley are all examples where bringing art into the community has helped in its revitalization. Fourteenth Street has been zoned as an Arts Overlay District from Rhode Island Avenue to the south, to Florida Avenue to the north. A great opportunity is therefore provided to promote the diversity and potential of the neighborhood through the development of an arts district.

A master plan for the 1500 block of 14<sup>th</sup> Street will form the foundation of the arts community, addressing its potential to extend north. Programming of the block will cater to the artist while still providing for the general public. Potential uses include an arts supply store, bookshop, and café. The adaptive reuse of existing buildings will be encouraged, ultimately resulting in a blend of new and old structures.

An Arts Center will be incorporated within the city block, acting as an anchor to the surrounding development. The ground floor of the building will seek to draw the public into the artists' realm through the incorporation of a café and gallery. Housing for artists will be located above, providing an environment for artists to live and work. A sense of place will be strived for through integration within the context. Ultimately, the image of the Art Center will define it as a significant landmark within the community.

Art is a way of bringing together people of different ages, ethnicities, and genders. This thesis will suggest how the Greater 14<sup>th</sup> Street District can regain its diversity through the development of an arts district and its reestablishment of 'place.'

## THE SITE

### SITE HISTORY

#### HISTORY OF WASHINGTON, D.C.

The plan for Washington D.C. was established in 1791 by the French Engineer Pierre L'Enfant. Boundaries included a ten mile square, with the Potomac River hugging its western border. The city of Paris and Gardens of French chateaus inspired the design of the new capital. The resultant

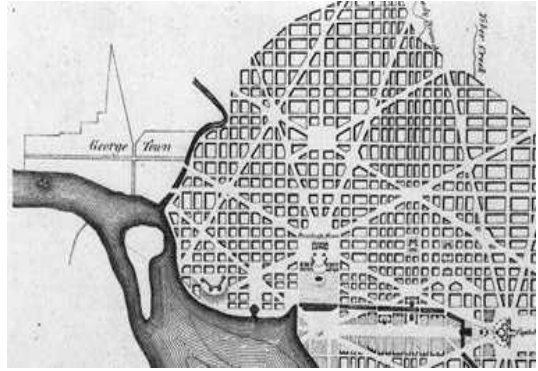


Figure 1: L'Enfant's Plan for Washington, D.C. [LCAA website]

street system consisted of diagonal boulevards and rectilinear streets. Diagonal avenues allowed quick access to key points in the city, while the rationale of the grid system formed reasonable lots for development and an easily navigable street network.<sup>1</sup>

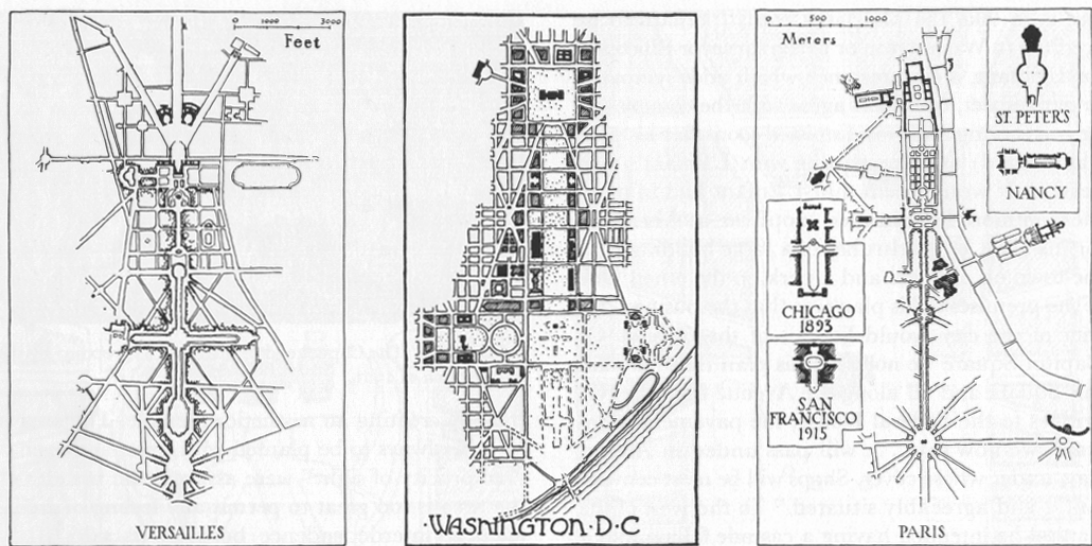


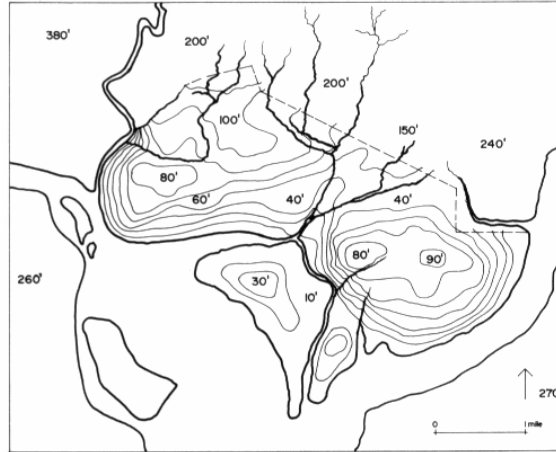
Figure 2: Comparison of Versailles, Washington D.C., and Paris. [Peets 46]

<sup>1</sup> Garvin, 76.

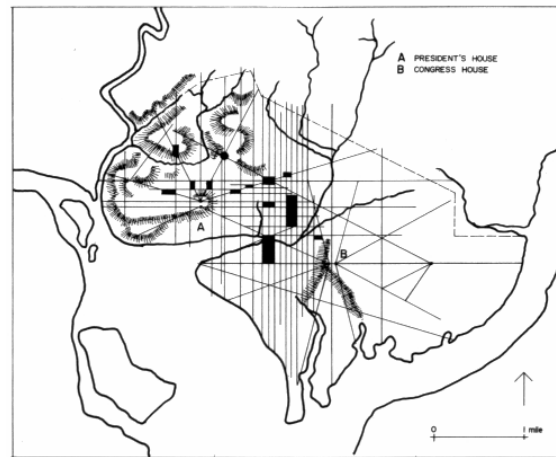


**Figure 3: 10-mile square of Washington D.C. [Peets 4]**

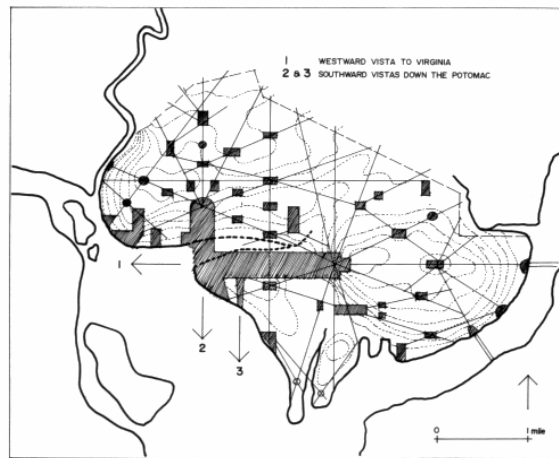
The plan was strongly influenced by the topography of the site. High points of the city were used to strategically locate the prominent buildings, resulting in vistas to the Potomac River. The President's House was to be located north of Tiber Creek, with a 10 mile view to the Potomac River, while the House of Congress was to be situated on Jenkins Hill, to the east. Monumental buildings were to be located between these two high points. Avenues radiated from these, stimulating the juxtaposition of the orthogonal street grid with the diagonal avenues. As stated by L'Enfant, "having first determined some principal points to which I wished to make the rest subordinate I next made the distribution regular with streets at right angles north-south and east-west but afterwards I opened others on various directions as avenues to and from every principal



**Figure 4: Topography of Washington, D.C. [Peets]**



**Figure 5: Nodes within plan of Washington, D.C. [Peets]**



**Figure 6: Vistas to Virginia, across the Potomac River. [Peets]**

space.”<sup>2</sup> He mentioned the numerous functions of diagonal avenues: to directly connect major points in space, to link orthogonal streets, to join significant spaces both visually and literally, contrast with regularity of grid, and to provide various lots and view corridors.<sup>3</sup> Resulting spaces provided additional locations for key buildings within the city.

Although the framework for the plan of L’Enfant has been implemented, many of his intentions went unrealized. Because the plan was so comprehensive, it was unrealistic that original plans would be completely followed through. For instance, the Washington Canal, rather than taking on its reason for being as an economic lifeline, became filled with trash and garbage. Instead of the Mall as a “Grand Avenue,” it was referred to as “waste” space.<sup>4</sup>

The year 1900 marked the one hundred year anniversary of Washington, D.C. as the Capital, instigating attention to the decrepit state of the city. Senator James McMillan formulated a commission which sought to revitalize its conditions. He hired Daniel Burnham, Frederick Law Olmsted Jr., Charles Follen McKim, Charles Moore, and Augustus St. Gaudens to prepare the report on developing the conditions. Park systems designed by Olmsted, Jr. emphasized the city’s topographical features, seeking to link neighborhoods and bring new life to the city.<sup>5</sup> Original intentions of L’Enfant began to be implemented as the national mall became a prominent axial link.

---

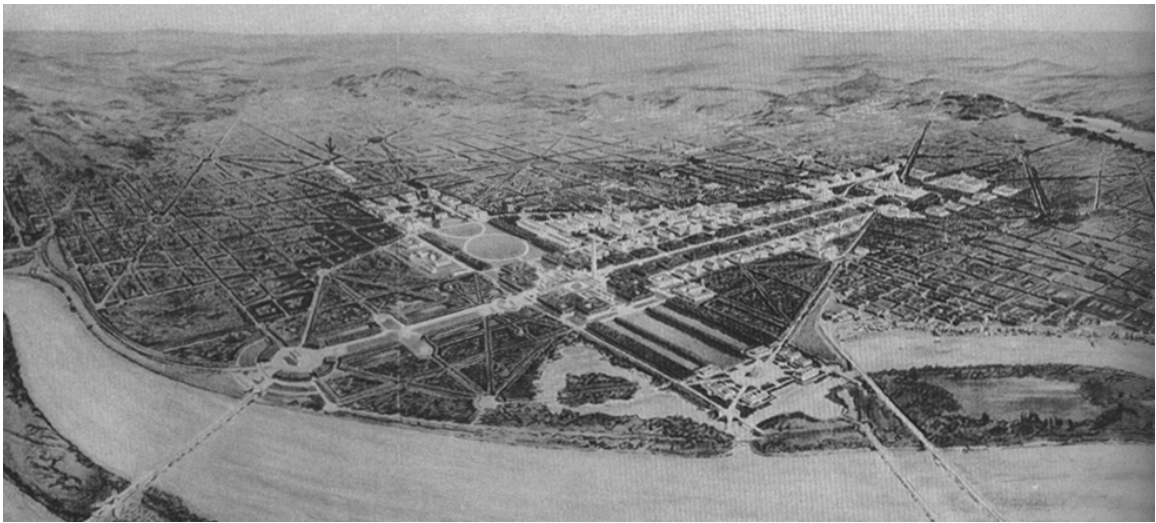
<sup>2</sup> Peets, 4.

<sup>3</sup> Reiff, 6.

<sup>4</sup> Washburn, 80.

<sup>5</sup> Garvin, 77.

The McMillan Plan helped the nation's capital become the city it is today. There are still isolated areas in need of repair, but the overall character of the city remains intact.



**Figure 7: Bird's Eye View of McMillan Plan, 1901-1903. [Garvin 78]**

## HISTORY OF LOGAN CIRCLE

Logan Circle, a result of L'Enfant's Plan, is a primary landmark near the site for this thesis. The statue found in the circle today was commissioned in 1891, demarcating its center. President William McKinley dedicated the statue on April 9, 1901.<sup>6</sup> In 1930, the circle was officially given its name, in memory of Civil War General and Senator John A. Logan. He had lived at #4 Logan Circle for the year prior to his death.<sup>7</sup>



**Figure 8: Statue @ Logan Circle. [LCCA Website]**

Logan Circle is the only area in Washington D.C. which maintains some of its Victorian architecture. The majority of the homes on the circle were constructed between 1874 and 1887, designed in an eclectic mix of styles including Second Empire, High Victorian Gothic, and Romanesque Revival. They remain unified through consistent heights, setbacks, scale, and texture. The intersection of the city's gridded streets and diagonal avenues on the circle result in irregularly shaped building lots. Therefore each home has distinct character, in contrast to adjacent streets where modest row houses are built in a repetitive fashion.<sup>8</sup>

---

<sup>6</sup> LCCA Website.

<sup>7</sup> Greater 14<sup>th</sup> Street and Logan Circle Brochure, 4.

<sup>8</sup> Greater 14<sup>th</sup> Street and Logan Circle Brochure, 4.

## HISTORY OF THE GREATER 14<sup>TH</sup> STREET DISTRICT

The development of the Greater 14<sup>th</sup> Street Area was not guided by formalized regulations, resulting in a diversity of housing types, residents, and income levels within the neighborhood. The wider streets, such as Vermont and Rhode Island Avenues, provided the optimum location for wealthier residents. The middle class gravitated towards the lettered and numbered streets, while the working class inhabited narrower streets and alleys, like Kingman Place. A diverse cross section of residents therefore lived within the neighborhood. Commercial activity tended to be located along the more heavily trafficked routes, such as 14<sup>th</sup> Street. The area characterizes the economic and racial diversity typical of nineteenth century urban development.<sup>9</sup>

In 1862 Congress permitted the Washington and Georgetown Railroad Company to build horse drawn streetcar lines along 7<sup>th</sup> and 14<sup>th</sup> Streets. The 14<sup>th</sup> Street line provided transportation for residents and Civil War supplies.<sup>10</sup> Since the streetcar line



*Photo courtesy of LeRoy O. King, Jr.*

**Figure 9: 14<sup>th</sup> Street streetcar, 1870's. [LCCA Website]**

made the 14<sup>th</sup> Street corridor easily accessible, it became an ideal location for commercial enterprises. Between the 1870's and the 1880's, the number and variety of commercial activity increased, creating competition between potential

businesses. Commercial storefronts with residences above provided shop owners the opportunity to live and work within one building. Some shops were built in pairs,

<sup>9</sup> Greater 14<sup>th</sup> Street and Logan Circle Brochure, 2.

<sup>10</sup> Greater 14<sup>th</sup> Street and Logan Circle Brochure, 2.

however generally each building was designed for a specific purpose and therefore had unique identity.<sup>11</sup>

In the 1870's, Alexander "Boss" Shepherd, the head of the city's Board of Public Works, commissioned a citywide improvement project for Washington D.C. Streets were paved and graded; gas, water and sewer lines were implemented; and thousands of trees were planted throughout the city. Population grew as dwelling units were built at an exponential rate. Logan Circle in particular became a popular place of residency, and was then landscaped as a public park. Additional streetcar lines were constructed along 9<sup>th</sup> and 11<sup>th</sup> Streets, increasing access in and out of the city.

The improvements to the Greater 14<sup>th</sup> District as a result of these changes attracted speculative developers to the area. They catered to the growing middle class, aiming to house government bureaucrats, office workers, and small business owners. The resulting architecture was characterized by a diverse mix of Italianate, Second Empire, Queen Anne and Romanesque styles.<sup>12</sup>

The Greater Fourteenth Street District reached a state of transition as transportation systems improved. The availability of the automobile in 1900's made the suburbs a popular place of residence for the middle class. At the same time, the city was growing northward along the streetcar lines, creating



**Figure 10: Fourteenth Street. [Greater 14<sup>th</sup> St & Logan Circle Brochure]**

---

<sup>11</sup> Greater 14<sup>th</sup> Street and Logan Circle Brochure, 11.

<sup>12</sup> Greater 14<sup>th</sup> Street and Logan Circle Brochure, 11.

another desired location for residency. Abandoned houses plagued the area as commercial properties also weakened.<sup>13</sup>



**Figure 11: Cars on 14<sup>th</sup> Street, 1930. [LCCA Website]**



**Figure 12: DeSoto-Plymouth Dealership on 14<sup>th</sup> Street, 1935. [LCCA Website]**

While residents were fleeing to more desired locations, 14<sup>th</sup> Street prospered as a hub for automobile exhibition, with automobile showrooms rising along the corridor. During the 1900's many existing Victorian homes and commercial structures were destroyed to make room for the new showrooms. Fourteenth Street was quickly nicknamed "Automobile Row," as side streets became more oriented to the service of automobiles. Repair shops arose on side streets such as Church Street and P Street. The buildings were typically multi-storied brick structures with an industrial aesthetic. Today there is not the same demand for such buildings and therefore many of these existing structures are presently vacant. Some have been adapted to meet modern needs, such as at 1526 14<sup>th</sup> Street. This automobile showroom has been converted to a thriving Studio Theatre while maintaining its original character.

---

<sup>13</sup> Greater 14<sup>th</sup> Street and Logan Circle Brochure, 11.

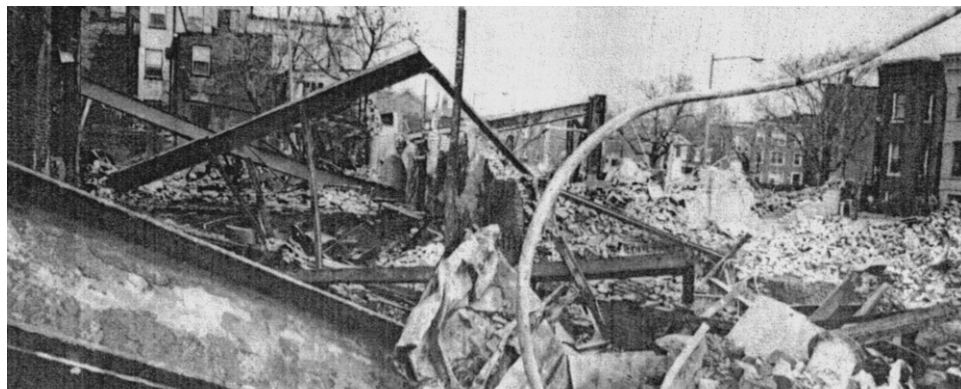


**Figure 13: 1526 14<sup>th</sup> Street in 1925. [Greater 14<sup>th</sup> St & Logan Circle Brochure]**



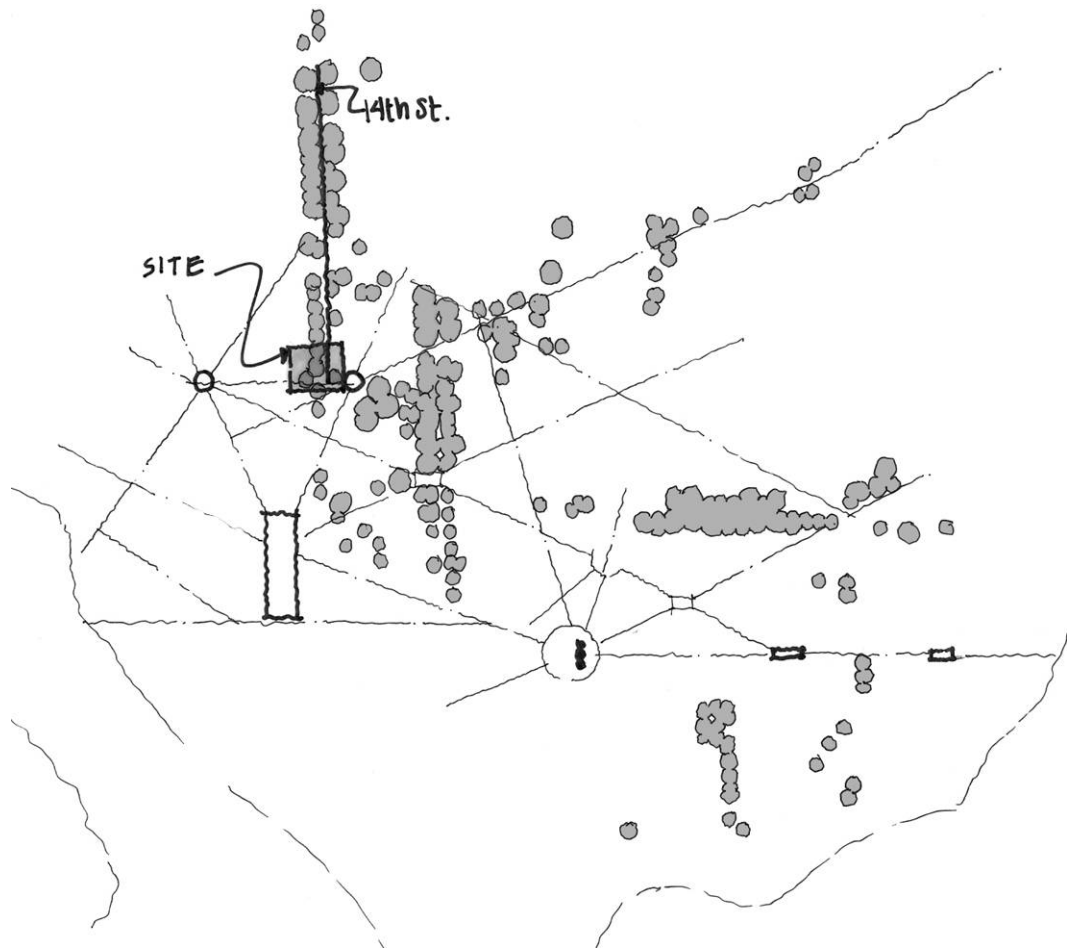
**Figure 14: 1526 14<sup>th</sup> Street in 2003.**

Following the assassination of Martin Luther King, on April 4 1968, riots broke out along 14<sup>th</sup> Street and quickly spread to other areas of the city. The Redevelopment Land Agency estimated citywide damage at 13.3 million dollars, with nearly half of that amount from losses along Fourteenth Street.<sup>14</sup> The corridor became a major target of the riots due to its abundance of commercial activity. Destruction was concentrated on commercial buildings; apartment buildings were usually only affected as a result of the burning of commercial spaces below. The losses during these riots greatly set back the development of this area of the city. Many of the buildings that burned down were never refurbished or rebuilt, destroying the essence of the commercial corridor.



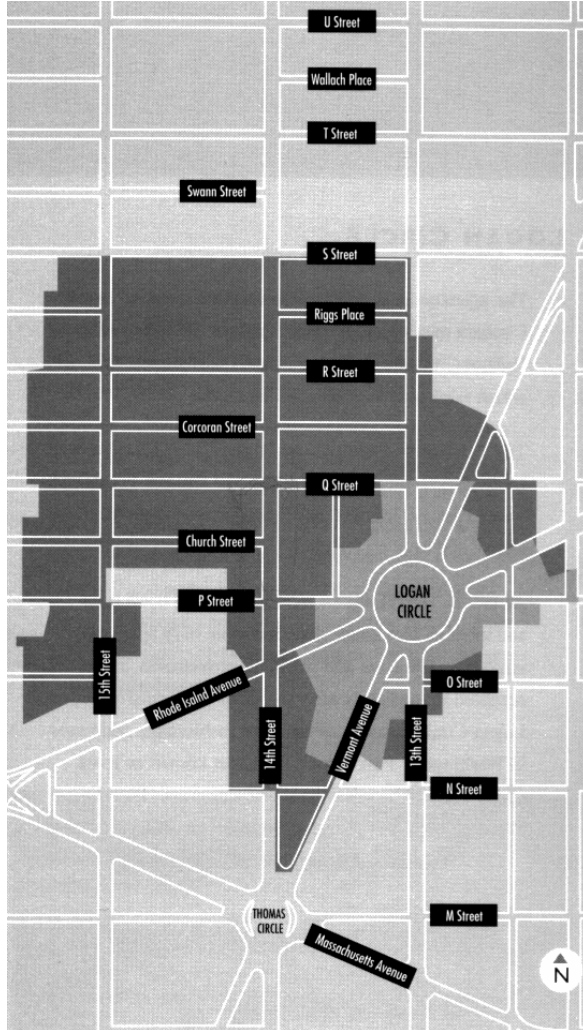
**Figure 15: Image of 14<sup>th</sup> Street after 1968 Riots. [Redevelopment Land Agency Document 15]**

<sup>14</sup> Redevelopment Land Agency Document, 15.



**Figure 16: Map of Citywide Damage**

## THE GREATER FOURTEENTH DISTRICT TODAY



**Figure 17: Greater Fourteenth Street and Logan Circle Historic Districts [Greater 14<sup>th</sup> Street and Logan Circle Brochure]**

In 1972 the Logan Circle Historic District was listed on the National Register of Historic Places. In 1994 the Greater 14<sup>th</sup> Street was listed as well, overlapping the Logan Circle District. The site for this thesis falls within the boundaries of the Greater 14<sup>th</sup> Street Historic District.

Fourteenth Street has potential for future development. Currently there is a movement toward the revival of this corridor, as developers are building on vacant lots and refurbishing old buildings. An increased number of residents are moving to the area as these revitalization efforts are being continued.

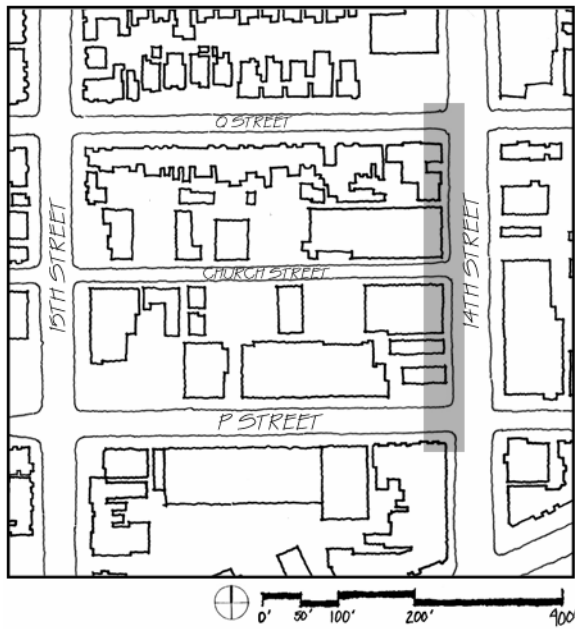
## **SITE DESCRIPTION**

The site for this thesis includes the 1500 block of 14<sup>th</sup> Street in Washington, D.C., between P and Q Streets. Logan Circle is located one block to the east of the site, while Dupont Circle is located five blocks to the west. P Street connects the two circles, becoming a significant route of travel. As 14<sup>th</sup> Street extends to the south, it connects to Thomas Circle, another product of L'Enfant's Plan for Washington, D.C.



**Figure 18: Aerial Photo, including Thesis Site. [D.C. Office of Planning]**

## WESTERN SIDE OF 14<sup>TH</sup> STREET – 1500 BLOCK



Several undeveloped lots disguise the continuity of the western side of 14<sup>th</sup> Street. An extreme condition occurs at the western corner of 14<sup>th</sup> Street and P Street, currently occupied by a surface parking lot. This location is prime for its relationship to these major thoroughfares and should therefore be better utilized.

**Figure 19: Plan Highlighting Western Side of 14<sup>th</sup> Street**

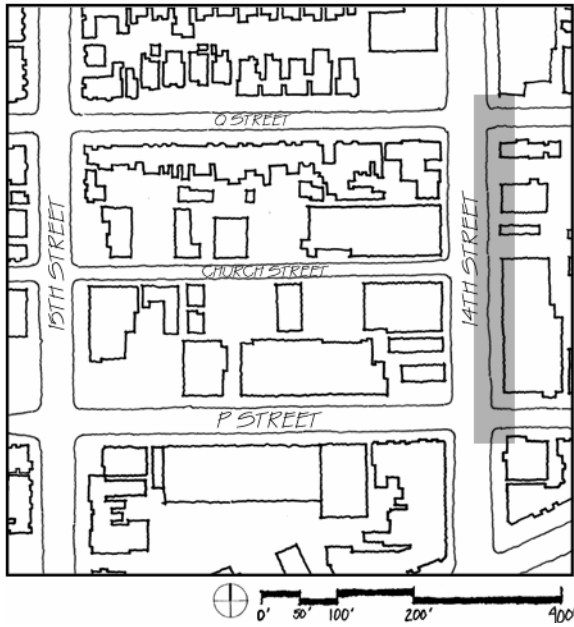


**Figure 20: Western Side of 14<sup>th</sup> Street**



**Figure 21: Western Side of 14<sup>th</sup> Street, cont.**

EASTERN SIDE OF 14<sup>TH</sup> STREET – 1500 BLOCK



Currently the eastern side of the 1500 block of 14<sup>th</sup> Street also has several vacant lots and abandoned structures. With the exception of the Studio Theatre on the South corner, most buildings are vacant and/or in need of major repair.

**Figure 22: Plan Highlighting Eastern Side of 14<sup>th</sup> Street**

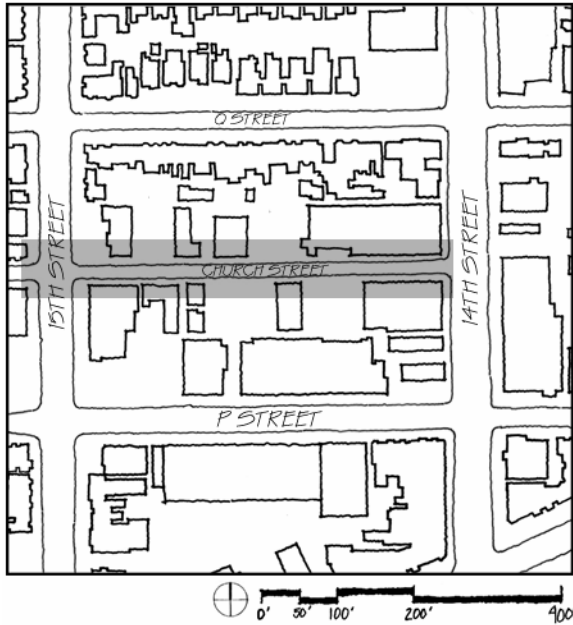


**Figure 23: Eastern Side of 14<sup>th</sup> Street**



**Figure 24: Eastern Side of 14<sup>th</sup> Street , cont.**

## CHURCH STREET



**Figure 25: Plan Highlighting Church Street**



**Figure 26: Vacant lot on Church Street**



**Figure 28: Perspective looking down Church Street**

Church Street once housed many automobile repair shops. Presently these shops are vacant, providing opportunity for rehabilitation. Vacant lots and abandoned buildings characterize the street. However, the two buildings on the corner of Church Street and 14<sup>th</sup> Street are presently being developed into market rate housing.

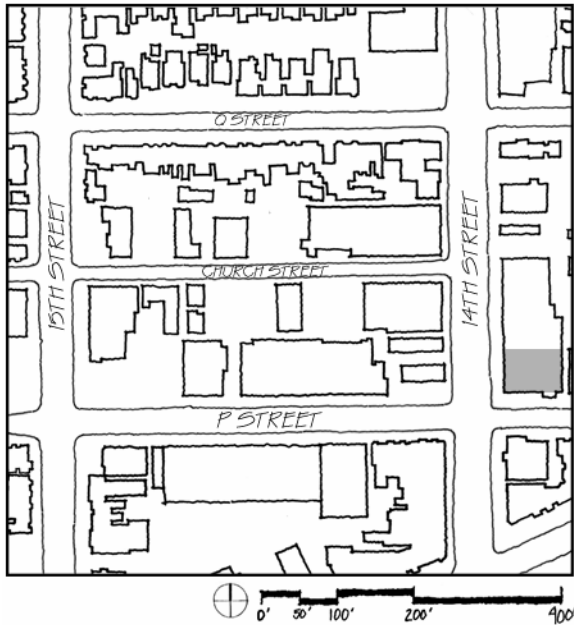


**Figure 27: Development @ Church Street and 14<sup>th</sup> Street**



**Figure 29: Automobile Repair Shop on Church Street**

## STUDIO THEATRE



**Figure 30: Plan highlighting location of the Studio Theatre**

In October of 1987 the Studio Theatre moved to its current location on the eastern corner of 14<sup>th</sup> Street and P Street. Once an automobile showroom, the building has been renovated to house the 200-seat Mead Theatre on the first floor, with office and classroom space above. The Milton Theatre, also seating 200 people, was added in March of 1997 as part of a \$5.5 million dollar renovation.

With this addition, the Studio Theatre

became a national model of the two-theater system. The theater has received national acclaim, receiving over 180 Helen Hayes Award nominations for artistic achievement.<sup>15</sup> The Studio Theatre enhances the artistic character of the neighborhood, while providing opportunities for those pursuing the art of entertainment.



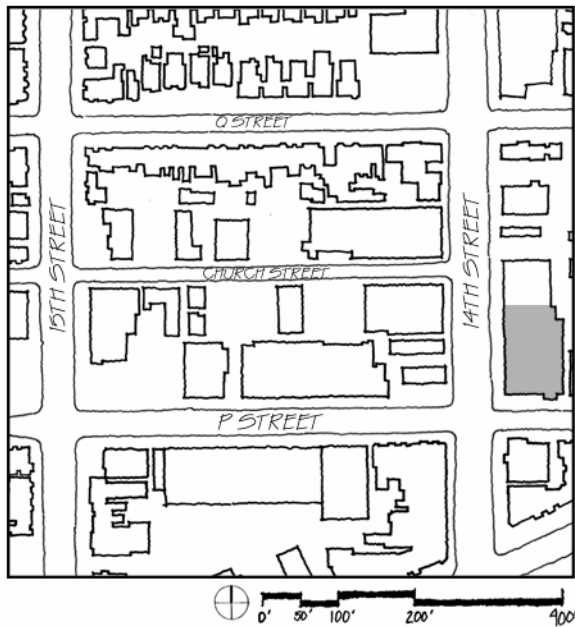
**Figure 31: Interior Renovations, 1997. [Kfoury Website]**



**Figure 32: Exterior of the Studio Theatre**

<sup>15</sup> Studio Theatre Website

## THE STUDIO THEATRE EXPANSION



**Figure 33: Plan highlighting location of Studio Theatre Expansion**

The Studio Theatre is continuing its addition and renovation, an \$11 million project that began on June 4 of 2003. The acquisition of the two adjacent buildings on 14<sup>th</sup> Street provides much additional space for the Studio Theatre. Award-winning Resident Designer Russell Metheny is heading the project, aiming to maintain the industrial aesthetic of the existing structures. Interior spaces of the three buildings will be opened up to

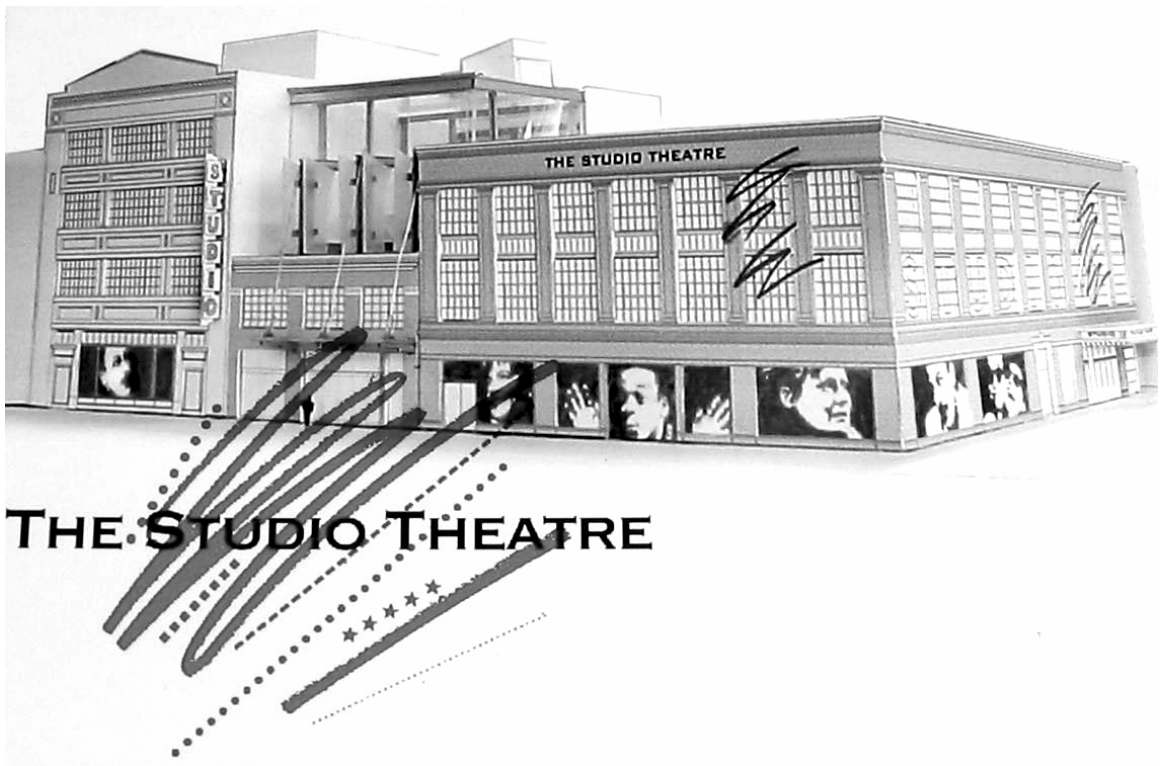
visually unite the interior, while providing a steady flow of traffic for artists, patrons and staff. The addition will provide: two new theatres, a new centrally located lobby, a marquee entrance on 14<sup>th</sup> Street, five new studios for the Acting Conservatory, an expanded lobby for the Milton Theatre, and a glass rooftop atrium on the central building.<sup>16</sup> Existing historic facades will be maintained while new architectural elements will be embellished to unify them.

---

<sup>16</sup> Studio Theatre Website

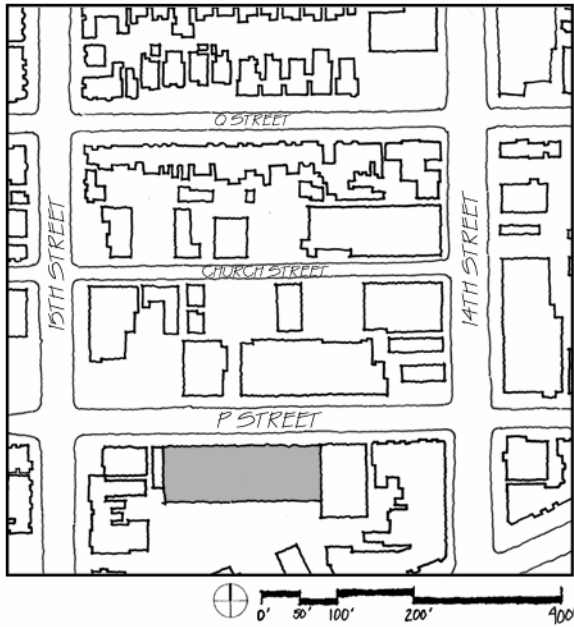


**Figure 34: Existing Studio Theater and Two Adjacent Buildings**



**Figure 35: Studio Theatre Expansion. [Metropolis Development]**

## WHOLE FOODS MARKET



**Figure 36: Location of Whole Foods Market**

The Whole Foods Market, located at 1440 P Street, is a significant destination within the neighborhood. Acting as an anchor, the store attracts both residents and visitors to the area. Outdoor seating makes the store not only a popular place for grocery shopping, but also for eating, socializing with friends, and people watching. Rooftop parking and two levels of subterranean parking address parking needs without overwhelming the site.

Whole Foods becomes a destination fully integrated within its urban context.



**Figure 37: Entrance**



**Figure 38: Outdoor Seating**



**Figure 39: Exterior of Whole Foods Market**

## SITE ANALYSIS

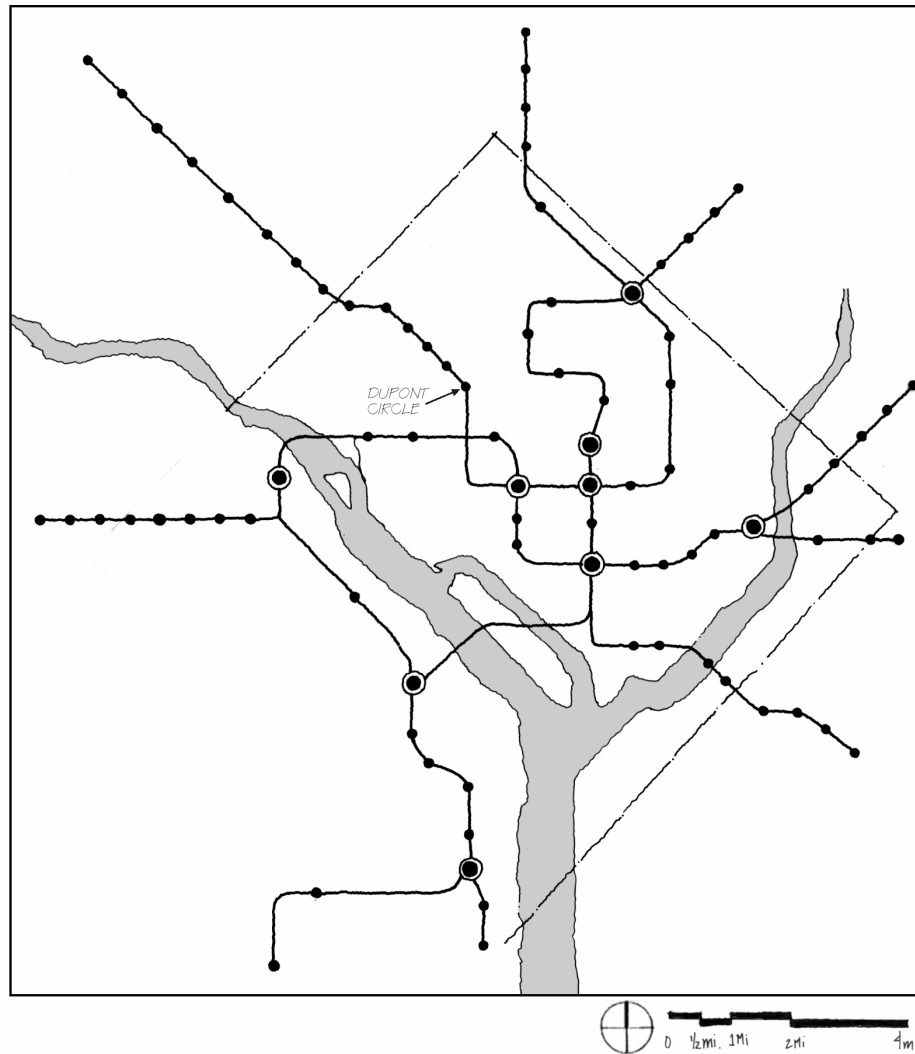
### REGIONAL



**Figure 40: Regional Diagram of Site and Context**

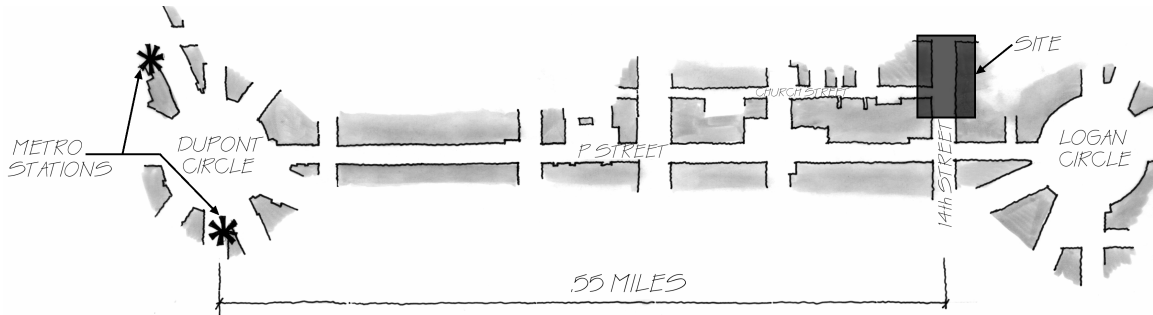
The Potomac River, which hugs D.C. on the west, branches off in Georgetown, flowing north through the city. The site for this thesis is located in Northwest Washington, D.C., between Dupont and Logan Circles. P Street runs between the circles, extending over the river to the west. Rock Creek Park runs alongside the river; together they act as a magnificent amenity for the city.

## MASS TRANSIT – METRORAIL SYSTEM



**Figure 41: Map of the Metrorail System**

The metro system running through the Metropolitan D.C. Area provides access to key points in Washington, Maryland, and Virginia. Dupont Circle is the metro stop in the closest proximity to the site. The stop is located on the red line, which runs from Shady Grove, Maryland, to Glenmont, Maryland. The walk from the stop to the site is approximately .55 miles along P Street. This portion of P Street is characterized by unique residences and lush landscaping.



**Figure 42: Diagram of walk from Dupont Circle Metro Station to the site, approximately .55 miles.**

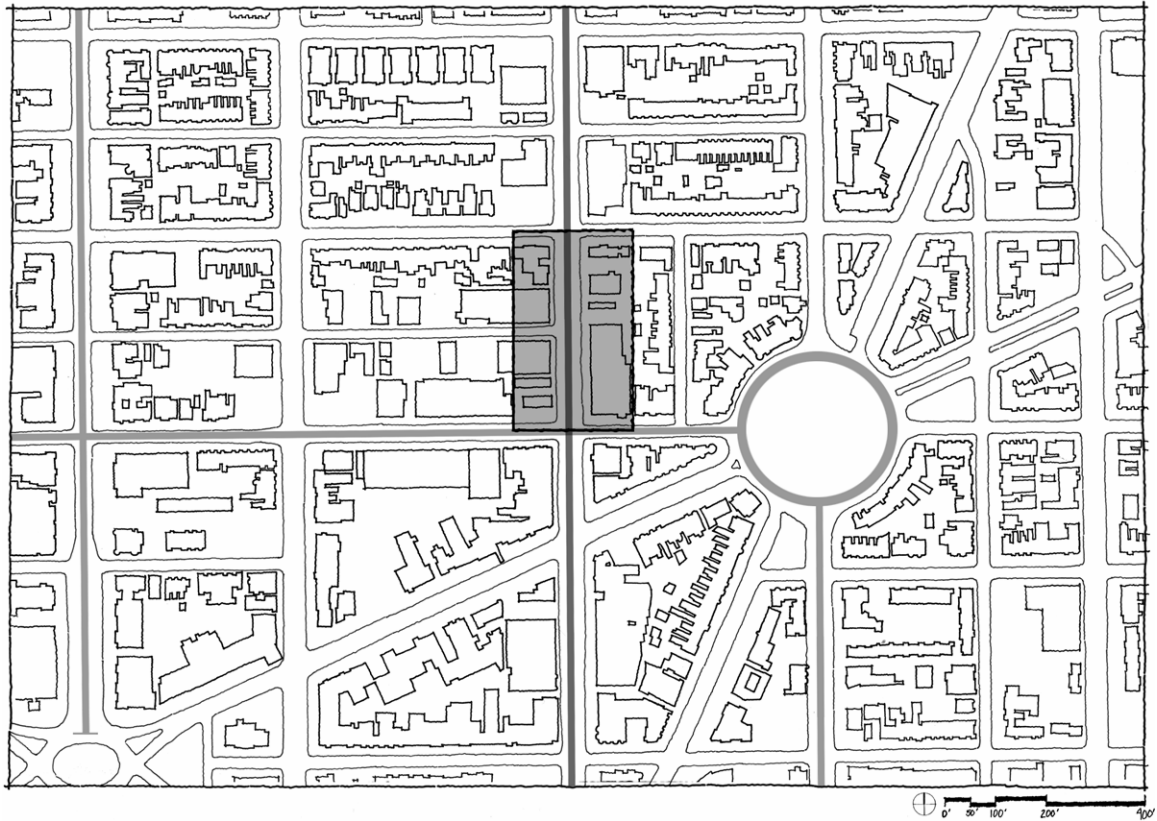


**Figure 43: Lush landscaping typical of P Street (between Dupont and Logan Circles)**



**Figure 44: Row homes characteristic of P Street (between Dupont and Logan Circles). Higher density housing occurs as well.**

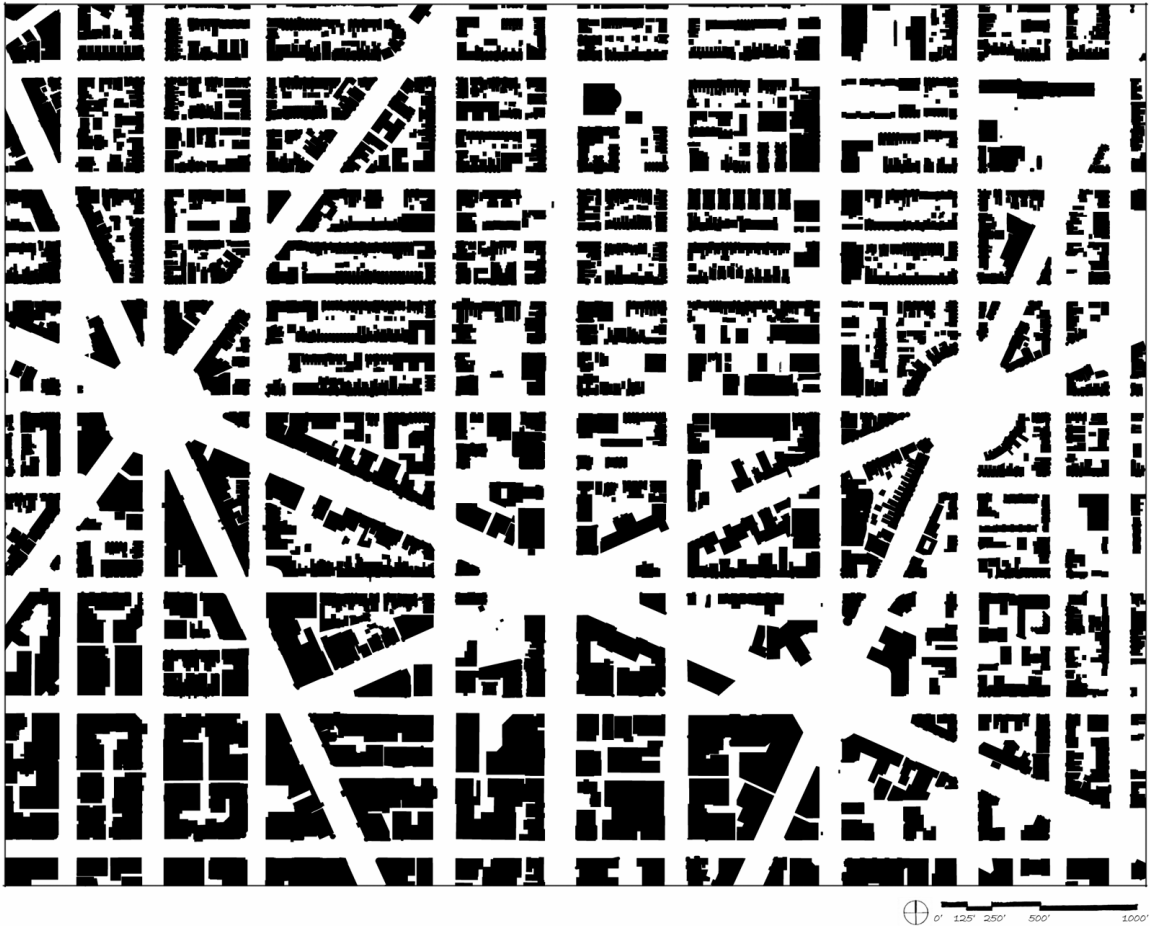
## MASS TRANSIT – METROBUS SERVICE



**Figure 45: Map of bus lines running through and around the site**

Metrobus service connects the site to various points throughout the city. Stops are more frequent than those of the metrorail lines, and the lines run through more areas of the city.

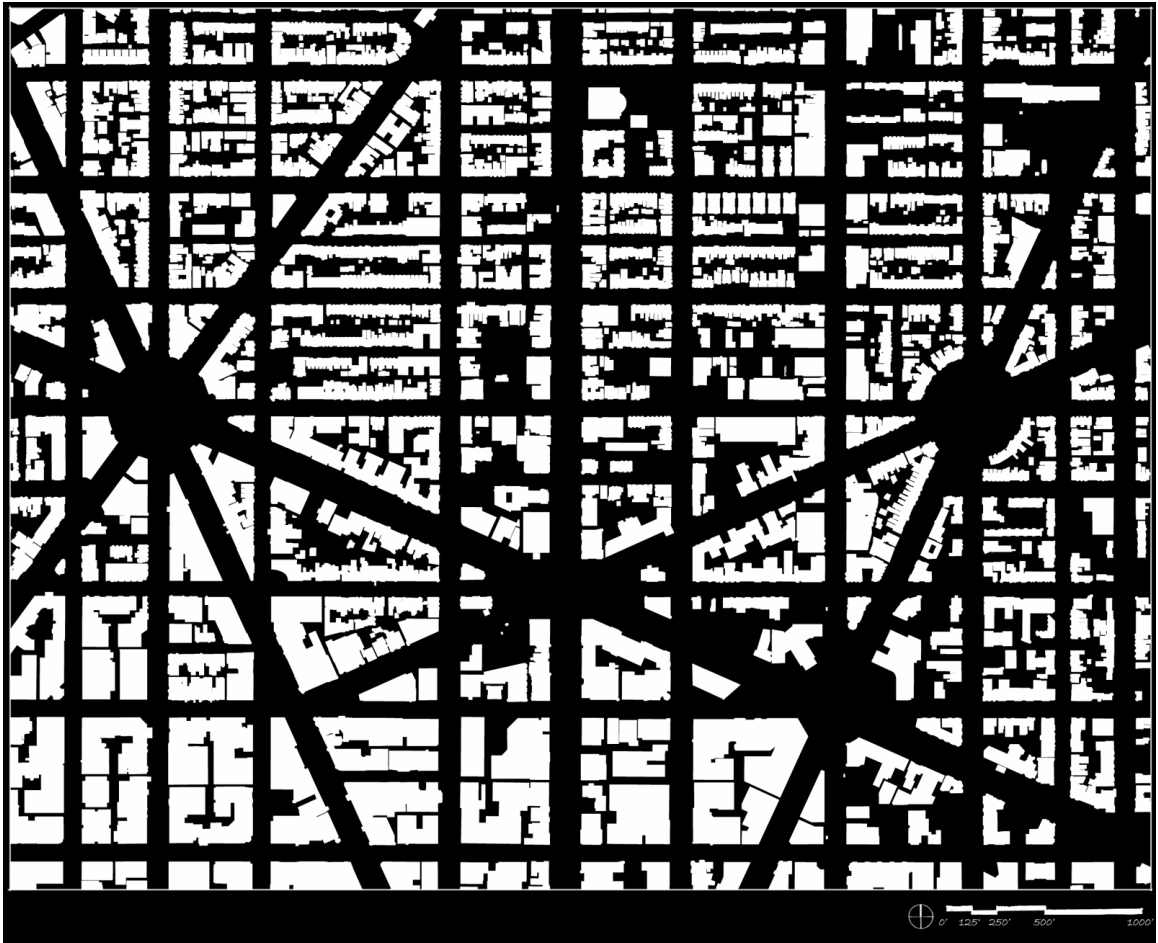
## FIGURE GROUND



**Figure 46: Figure Ground of Site and Greater Context**

There are distinct differences in scale between the blocks to the north of the site and those to the south. Blocks to the north are made of a series of smaller buildings and row homes, defining a residential quality. Buildings to the south of the site tend to be much larger in scale. Large building masses clearly define Dupont Circle, to the west, while small scale buildings surround Logan Circle.

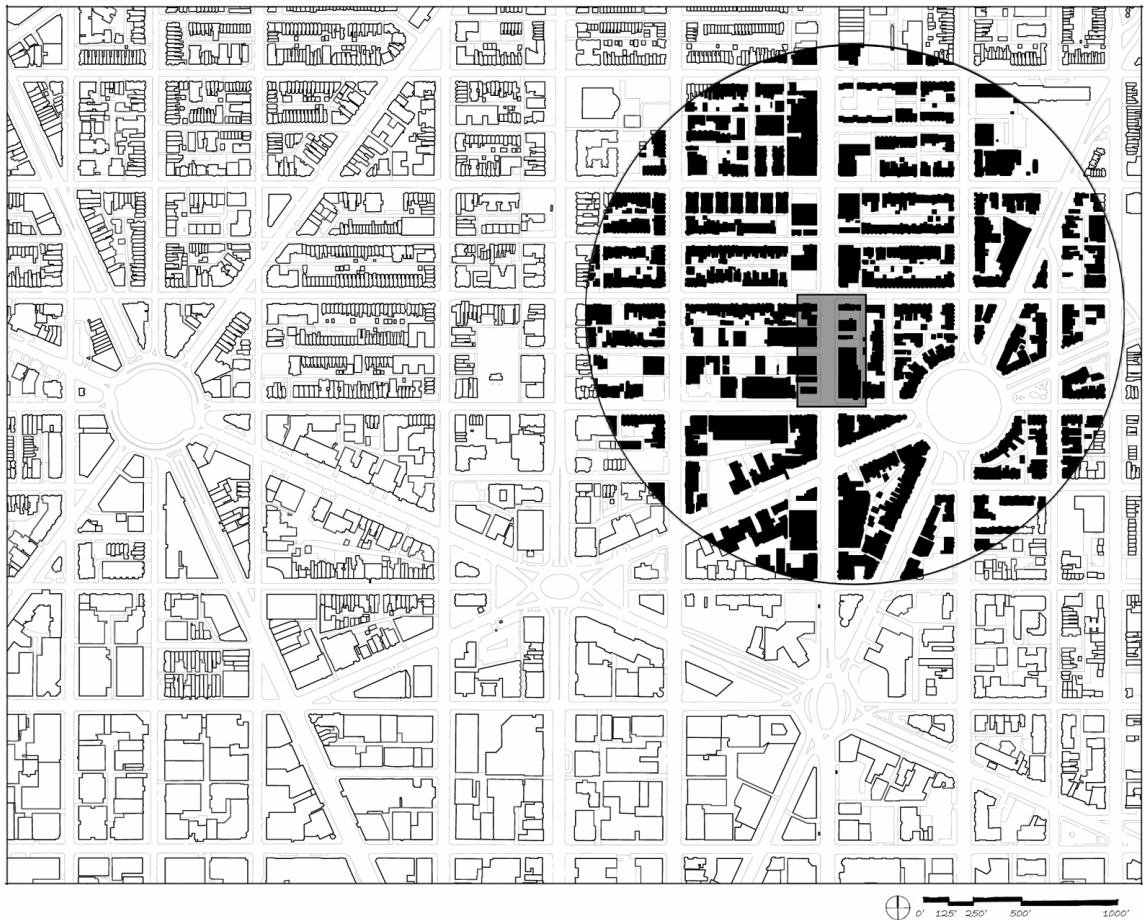
## FIGURE GROUND REVERSAL



**Figure 47: Figure Ground Reversal of Site and Greater Context**

The majority of open spaces in this area of Washington, D.C. are primarily a result of the nodes formed by L'Enfant's plan. The diagonal avenues connecting them become of primary importance.

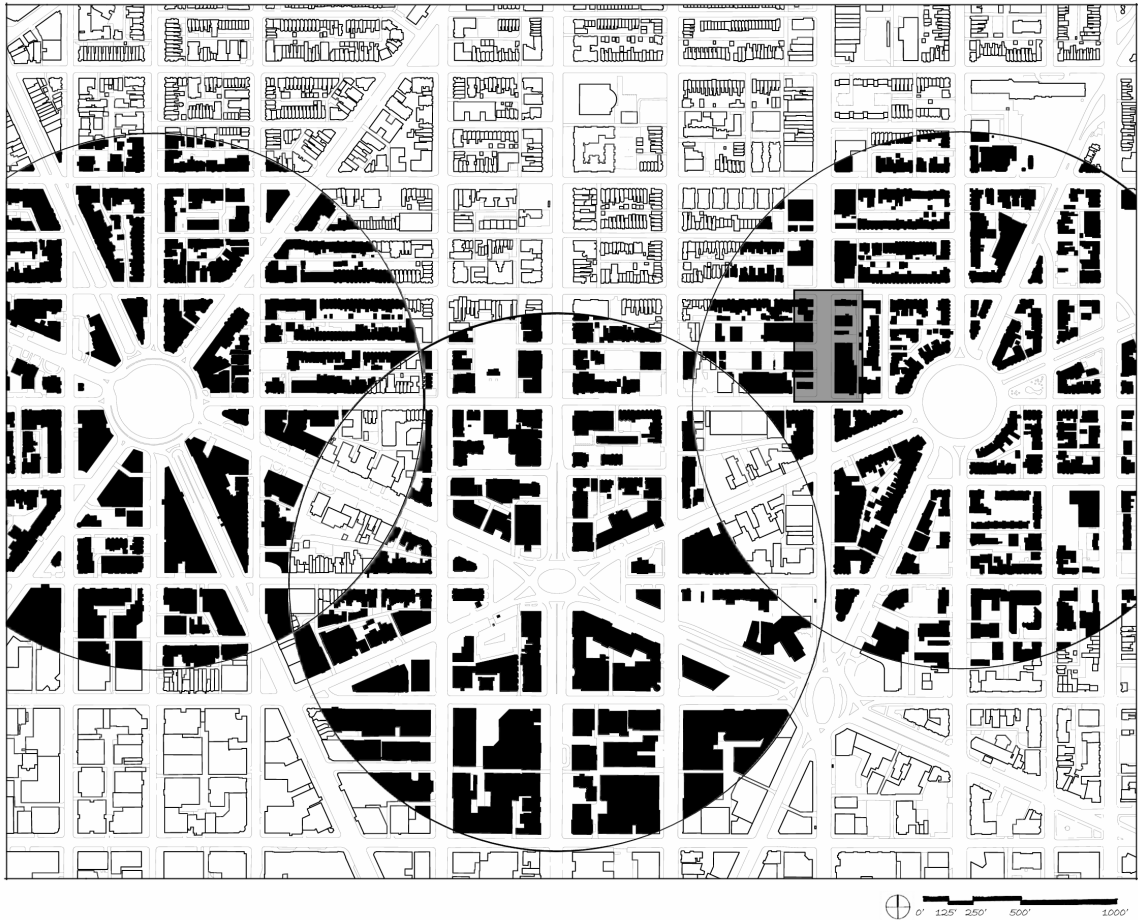
## WALKABILITY – FIVE MINUTE WALK FROM SITE



**Figure 48: Five-minute walk diagram from the site**

An abundance of residences are easily accessible within a five minute walk from the site. Logan Circle is a major landmark close to the site, as is the Fresh Fields Market on P Street. To the south, the Caribou Coffee House and small cafes help anchor retail beginnings. The abundance of homes near the site will provide a substantial clientele for the scope of this thesis.

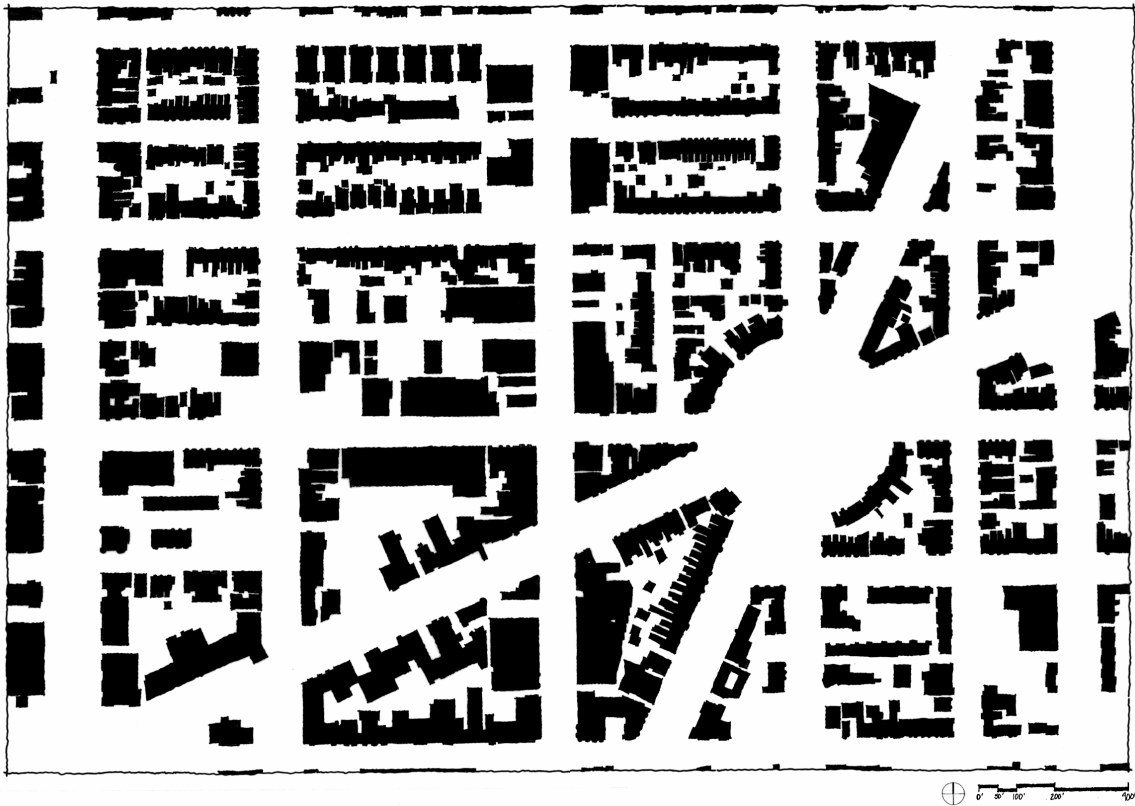
## WALKABILITY – FIVE MINUTE WALK FROM NODES



**Figure 49: Five minute walk from nodes close to site (nodes from L to R: Dupont Circle, Scott Circle, and Logan Circle).**

Three nodes are in close proximity to the site for this thesis. Each is within a five-minute walk from the next. Scott Circle, centrally located, is the most accessible from the other locations.

## FIGURE GROUND

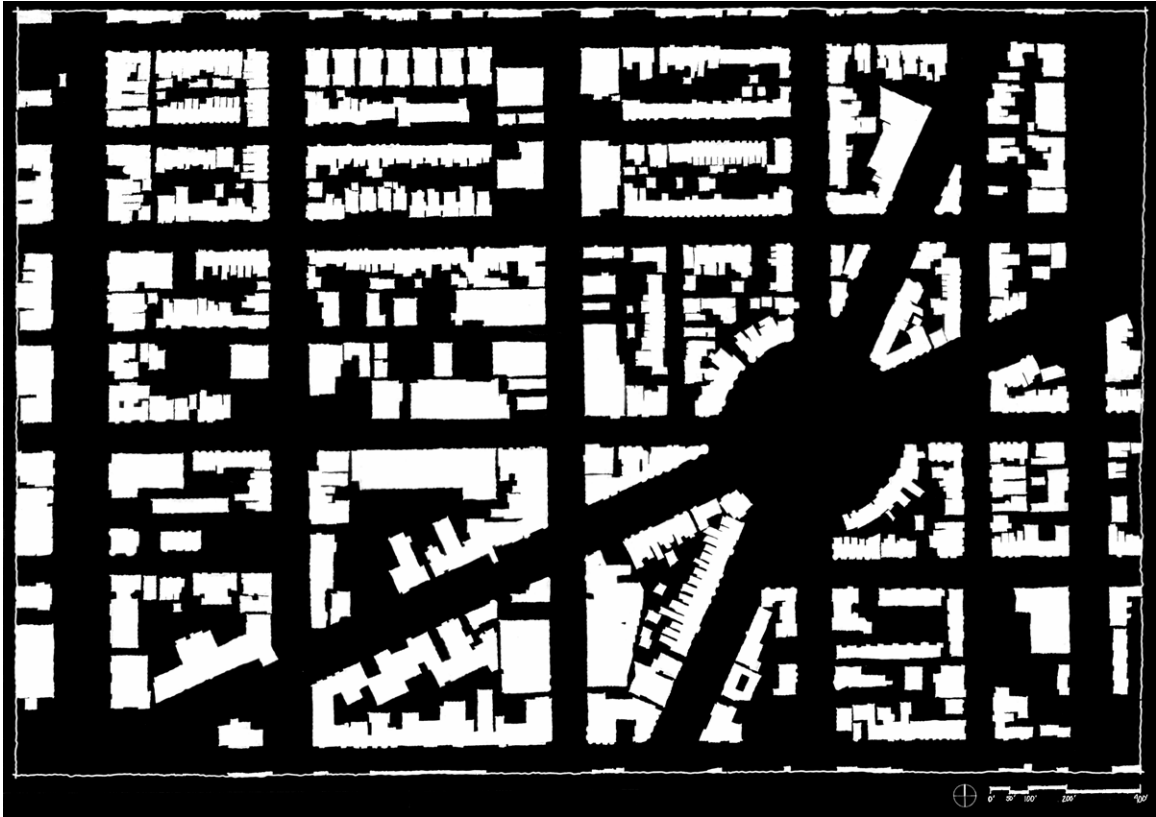


**Figure 50: Figure Ground of site and immediate context**

Building fabric ranges from large scale buildings to small blocks of row houses. Logan Circle is enclosed by these row homes, where other areas are more ill-defined. The disparate fabric along the 14<sup>th</sup> Street corridor provides opportunity for development. Moving north along the street, the vacancies increase.

There is also a pattern of east-west streets being defined by row houses, while larger structures are found on north south streets, especially along 14<sup>th</sup> Street. These streets act primarily as commercial corridors, accounting for the larger buildings.

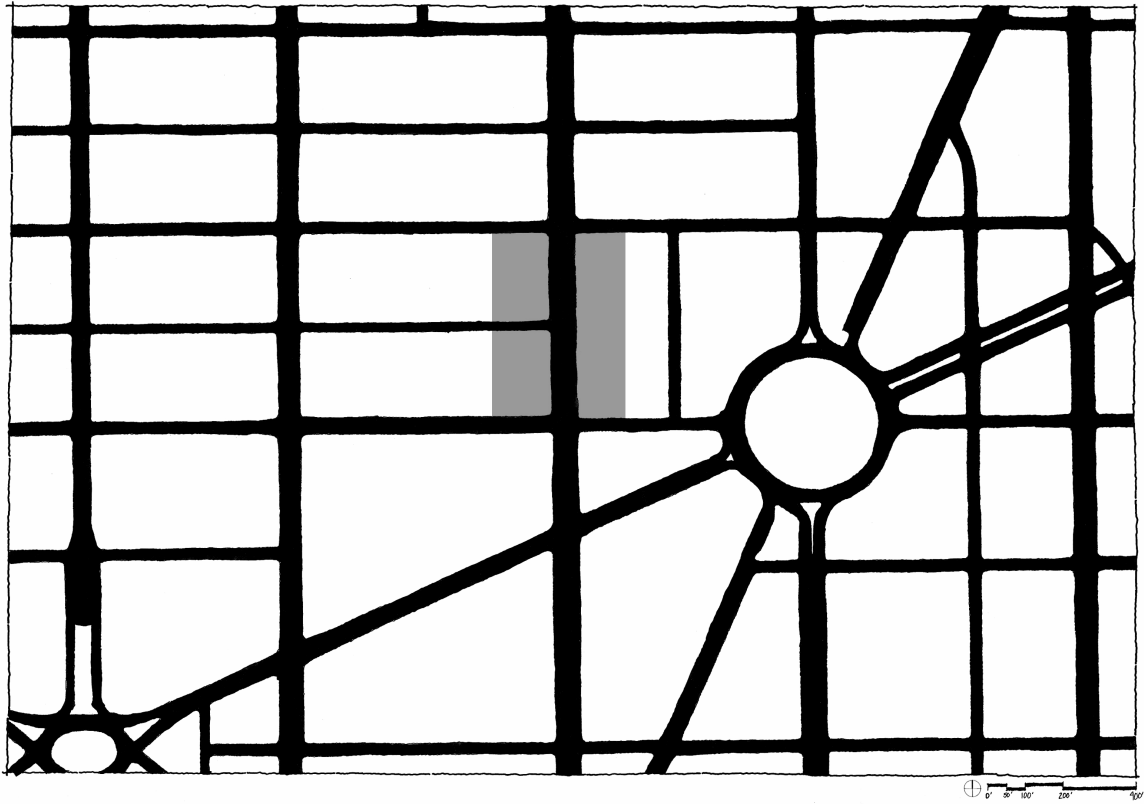
## FIGURE GROUND REVERSAL



**Figure 51: Figure Ground Reversal of Site and Immediate Context**

Street frontage is very prominent in most areas, but there are several locations that are ill-defined. Numerous corners are wasted with vacancies and parking lots. The weak definition of these spaces causes them to blend together, masking the street grid.

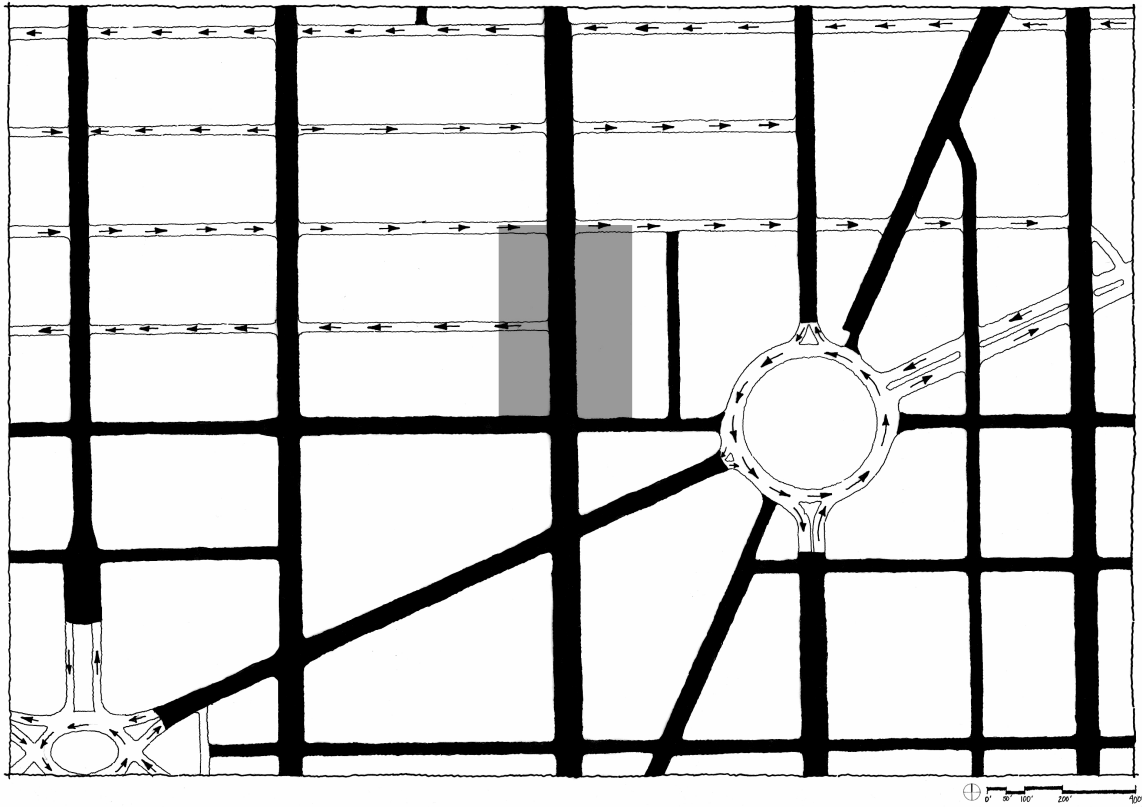
## STREET HIERARCHY



**Figure 52: Diagram of Street Network**

A clear system of streets organizes the area. Primary streets include diagonal avenues and north-south streets, evident in their width. There is a system of secondary and tertiary streets running east to west. Secondary east-west streets are wider and more continuous than the tertiary streets. The complex street system forms clear primary, secondary, and tertiary streets, with resulting blocks running east to west.

## VEHICULAR CIRCULATION



**Figure 53: Diagram of Traffic Conditions Near Site**

Vehicular circulation is made up of a series of one-way and two-way streets. All north-south and diagonal streets carry two-way traffic. One-way traffic occurs along east-west streets, primarily to the north of the site. Church Street traffic, on access with the site, moves to the west. Although cars cannot approach the site from Church Street, it is a frequent route of travel for pedestrians. The street is therefore an important view corridor to the site.

## BUILDING USE

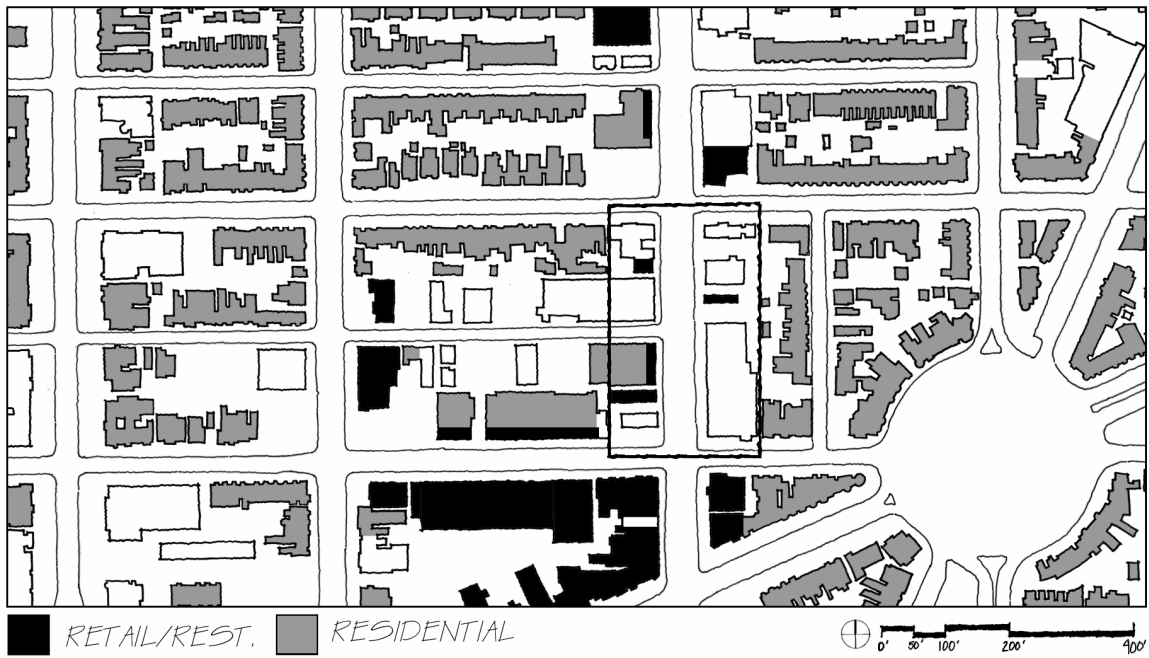


Figure 54: Retail/restaurant and residential uses near the site

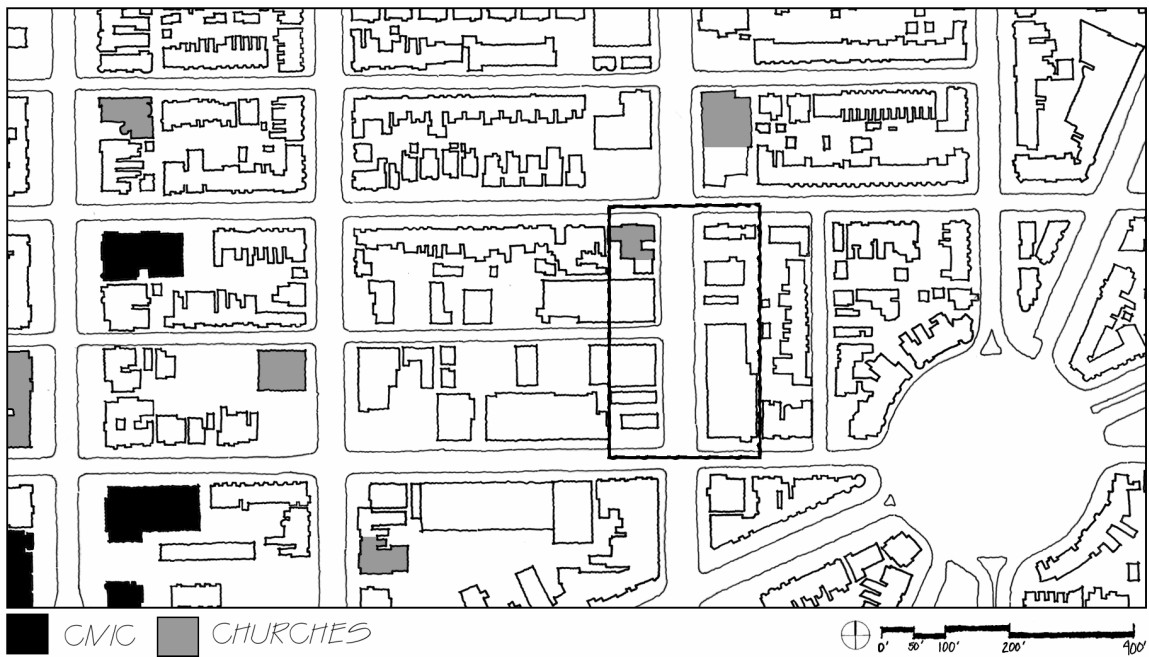
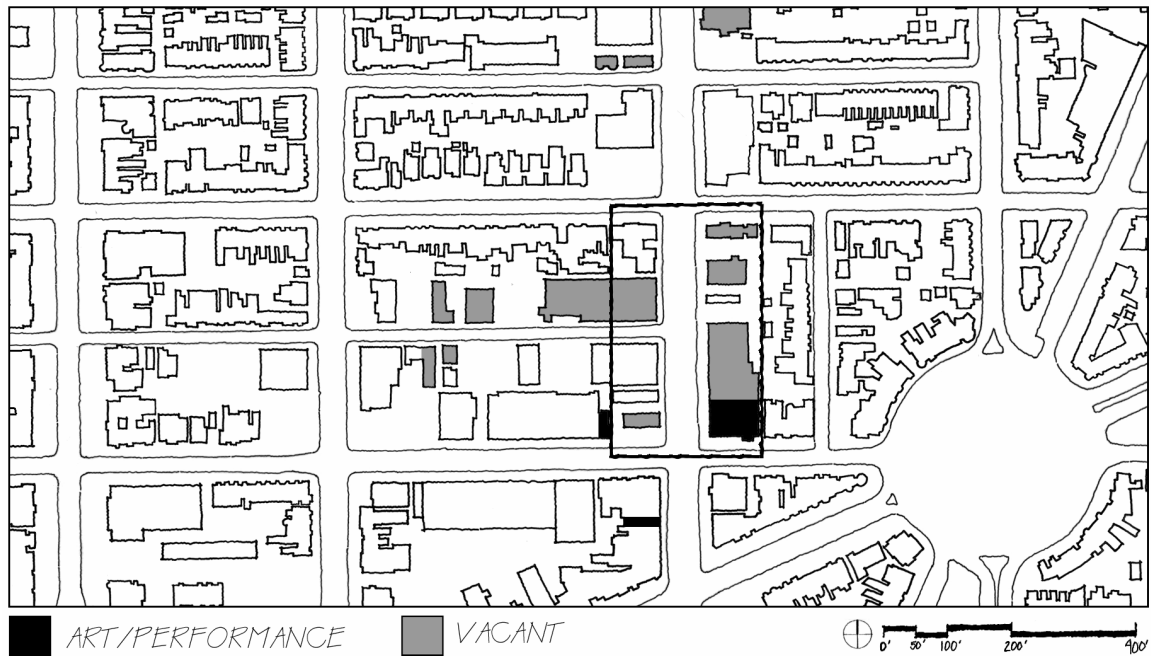


Figure 55: Civic buildings and churches near the site

BUILDING USE  
(cont.)



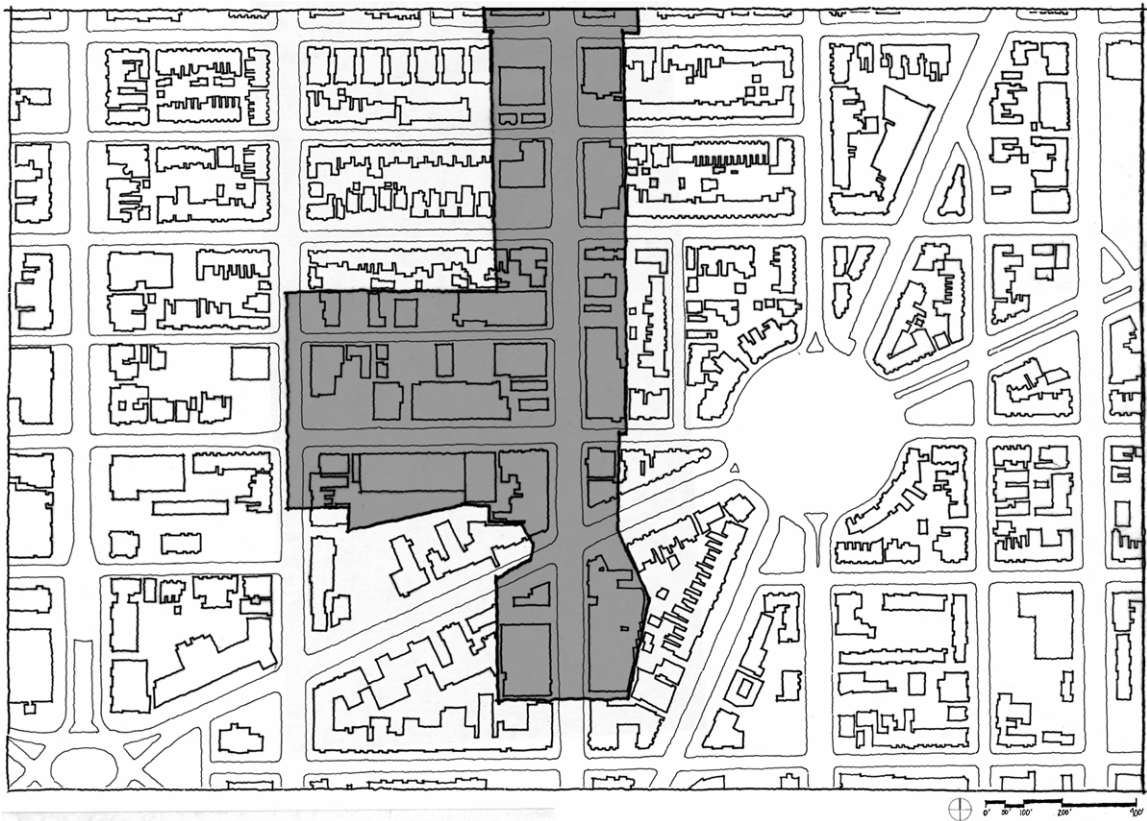
**Figure 56: Art/performance spaces and vacancies near the site**

There is an abundance of residential units surrounding the site. Retail activates the ground level of several apartment buildings, primarily to the south. Based on the existing residential and retail uses that already occur within close proximity, a clientele already exists for the arts community.

Sixteenth Street, two blocks west of 14<sup>th</sup> Street, becomes a major location for civic buildings. Currently housing many embassies, the street is significant due to its location on axis with the White House. Numerous churches are also scattered close to the site, accounting for the name given to “Church Street.”

A majority of vacancies near the region occur closest to the site, along Church Street and 14<sup>th</sup> Street. Art and performance spaces are primarily located along the 14<sup>th</sup> Street corridor, creating opportunity to expand on existing uses.

## ZONING



**Figure 57: Uptown-Mixed Use (ARTS) Overlay District**

The site for this thesis is located within the Uptown Arts-Mixed Use (ARTS) Overlay District. According to the District of Columbia Municipal Regulations, the purposes are to:

- Encourage a scale of development, a mixture of building uses, and other attributes such as safe and efficient conditions for pedestrian and vehicular movement, all of which will be as generally required by the Comprehensive Plan;
- Require uses that encourage pedestrian activity, especially retail, entertainment, and residential uses;
- Provide for an increased presence and integration of the arts and related cultural and arts-related support uses;

- Expand the area’s housing supply in a variety of rent and price ranges;
- Expand business and job opportunities, and encourage development of residential and commercial buildings;
- Strengthen the design character and identity of the area by means of physical design standards;
- Encourage adaptive reuse of older buildings in the area and an attractive combination of new and old buildings; and
- Foster eighteen (18) hours activity and increased public safety.<sup>17</sup>

---

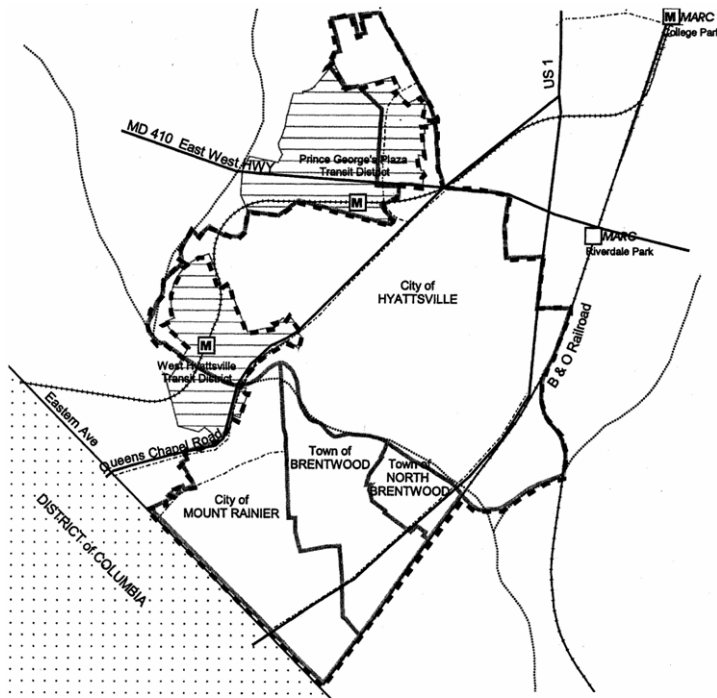
<sup>17</sup> District of Columbia Municipal Regulations, Section 1900.2

## PRECEDENT STUDIES

### ARTS DISTRICTS

UPCOMING ARTS DISTRICT: GATEWAY ARTS DISTRICT, by Artspace, Inc.

Artspace, Inc. was created in 1979 to assist working artists pushed out of their homes in the historic Warehouse District of Minneapolis. The company began by designing individual buildings in Minnesota for artists to live and work. Their growth since then has led them to assist in the development of arts districts across the country, seeking to revive communities and provide positive live/work environments for artists. All projects completed by Artspace have produced positive cash flow, and therefore they have never had to provide additional assistance once their communities were fully operational. Given the experience of the company, the studies and developments of Artspace, Inc. prove to be a valuable source for this thesis.



**Figure 58: Map of Gateway Arts District [Gateway Arts District Sector Plan and Sectional Map Amendment]**

Artspace, Inc. and Prince George's County are currently working together on the development of an arts district along the Route 1 corridor. The boundary for the district begins at the District of Columbia boundary and extends northward for about two miles. Included are the municipalities of Hyattsville,

Mount Rainier, Brentwood, and North Brentwood.

Four anchor projects are proposed to catalyze new art related development to the Prince George's County Gateway Arts District. They include spaces for artists to live and work in each of the four municipalities. Incubator space for arts businesses will be incorporated into the Mount Rainer project. The Brentwood live/work project will include a privately run community center. Gallery space will be housed within the Hyattsville project. North Brentwood will have a "black box" rehearsal and performance theater and a museum.<sup>18</sup> These four projects will begin to reach out to the greater community while forming the foundation of the arts district.

Artspace, Inc. recognizes that these anchors alone can not create an arts district. The projects must be strategically connected and supported through additional programming. Connection is important for visitors must feel they are in a unified area rather than visiting an isolated project. Artspace, Inc. has proven over time that art and culture can revive a community. According to the Gateway Arts District Planning Study, "Arts programming and cultural facilities development are place-making strategies and important components of a vital arts district; they contribute to economic revitalization and help reinforce community pride and cultural identity."<sup>19</sup>

Additionally, it is assumed that the development of the anchor projects will facilitate spin-off benefits for the community. According to Artspace Inc., these benefits include:

- Local and regional retail establishments that accommodate eating, drinking, convenience, and specialty shops.

---

<sup>18</sup> Gateway Arts District Planning Study, 19.

<sup>19</sup> Gateway Arts District Planning Study, 14.

- Increased development of “creative businesses” such as architecture firms, graphic design companies, cutting edge technology companies, etc.
- Additional studio space beyond that planned by Artspace, Inc.<sup>20</sup>

According to the planning study, a potential challenge of the project is its location in the urban fringe. Typically, successful arts districts have been found in city centers.<sup>21</sup>

Currently the zoning along the Route 1 corridor does not permit all of the uses ideal for an arts district. Ideally, the following uses would be found to create a viable arts district:

- Art center
- Art gallery
- Art school (includes dance, photography, filmmaking, music, writing, painting, sculpturing, or printmaking)
- Artist housing
- Artist studio
- Artists’ supply store
- Arts services, including set design and restoration of artworks
- Concert hall or other performing arts space
- Bookstore
- Cabaret
- Craftsman or artisan
- Dinner theater
- Drinking places, including bar, nightclub, or cocktail lounge
- Legitimate theater
- Movie theater
- Museum
- Performing arts ticket office or booking agency
- Photographic studio
- Picture framing shop
- Record store, musical instruments store
- Restaurant
- Television and radio broadcast studio<sup>22</sup>

---

<sup>20</sup> Gateway Arts District Planning Study, 14.

<sup>21</sup> Gateway Arts District Planning Study, 17.

<sup>22</sup> Gateway Arts District Planning Study, 23.

## EXISTING ARTS DISTRICT: SHORT NORTH, OHIO

In 1920, High Street defined the Short North Area in Columbus, Ohio as a flourishing urban center. However, after the construction of Interstate 670, the area quickly became defined by slum housing and neglected commercial buildings. Crime, drugs, and prostitution plagued the area. Revitalization began in the mid 1970's as historic renovation became a popular trend in the neighborhood. "Urban homesteaders" began purchasing cheap dilapidated buildings to renovate, instigating the dramatic changes that have occurred over the past three decades. Presently, the neighborhood is an active arts district, featuring restaurants, small boutiques and shops, art galleries, and residences.<sup>23</sup>

The Short North Arts District lies within the city of Columbus, Ohio. The district runs along North High Street, extending from 5<sup>th</sup> Avenue to Interstate 670. This distance is almost one mile long. Downtown Columbus is located just south of the site, easily accessible by automobile. To the east, Goodale Park provides the neighborhood with the amenity of a landscaped recreational area.

Although Short North has Goodale Park in close proximity, pocket parks are utilized as a way to bring landscaping closer to the urban realm. The Short North Special Improvement District (SID) defines a pocket park



**Figure 59: Map of Short North, arts corridor is highlighted.**

<sup>23</sup> [www.woodcompanies.com/History.htm](http://www.woodcompanies.com/History.htm)

as “a tiny green space that can be found in an unexpected place.”<sup>24</sup> Along the stretch of High Street that defines the arts district, there are at least 20 pocket parks. Precedents for such green spaces can be found in cities such as San Francisco and Chicago. Pocket parks in Short North are used as a way to continually redefine the city’s image by implementing public art and references to historical buildings into the spaces.<sup>25</sup>

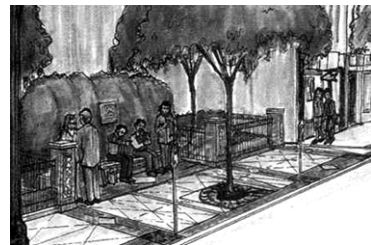
Programming along North High Street includes a mix of galleries, restaurants, and residences. Similar to Arts Districts across the United States, Short North has a gallery hop on the first Saturday of each month. The Short North Arts District is a prime example of how bringing art and historic preservation into the community can help in its revitalization.



**Figure 63: Crowds at Gallery Hop. [Short North Gazette Website]**



**Figure 60: Goodale Park. [Short North Website]**



**Figure 61: Pocket Park. [Short North Website]**



**Figure 62: Street performers are popular in Short North. [Short North Gazette Website]**



**Figure 64: Arches on High Street. [Short North Gazette Website]**

<sup>24</sup> [www.theshortnorth.com/pocketparks.htm](http://www.theshortnorth.com/pocketparks.htm)

<sup>25</sup> [www.theshortnorth.com/pocketparks.htm](http://www.theshortnorth.com/pocketparks.htm)

## ARTISTS STUDIOS/GALLERIES

### TORPEDO FACTORY ART CENTER

The City of Alexandria purchased The Torpedo Factory in 1969 and converted it into an art center. The building was used as a storage unit after the war when there was no longer a need for the manufacture of torpedoes.<sup>26</sup> The spacious interior has proven to be an optimal location for the art center.

Programmatic elements include:

- 84 working studios
- 8 group studios
- 6 main galleries
- classrooms for teaching & community outreach programs

The art center provides studios for 165 artists of various media.

These include painting, pottery, photography, jewelry, stained glass, fibers, printmaking, and sculpture.<sup>27</sup> Communication between artists and visitors makes the Torpedo Factory an interactive learning experience.



**Figure 65: Target Gallery, national exhibition space. [Torpedo Factory Website]**



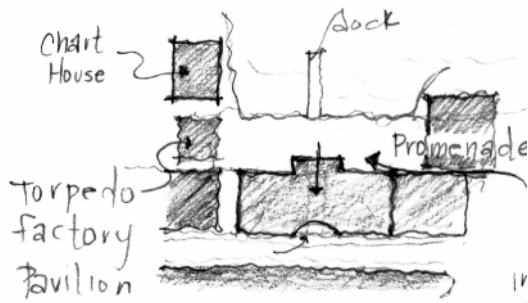
**Figure 66: Sculptural Stairs in Torpedo Factory**

---

<sup>26</sup> Torpedo Factory Website

<sup>27</sup> Torpedo Factory Website

There are two main entrances to the Torpedo Factory. One is located on the western side, along North Union Street. The other is off of a plaza adjacent to the Potomac River. This entry becomes much more prominent since the art center acts as a focal point within this plaza.



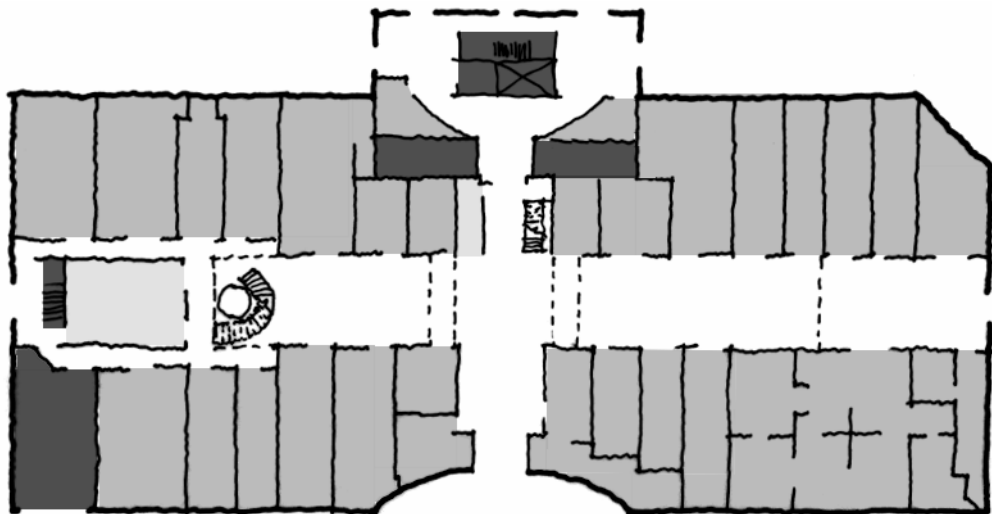
**Figure 67: Diagram of Entrances**



**Figure 68: Eastern Entry- Plaza on Potomac**



**Figure 69: Western Entry- N. Union Street**



**Figure 70: Plan of Torpedo Factory**

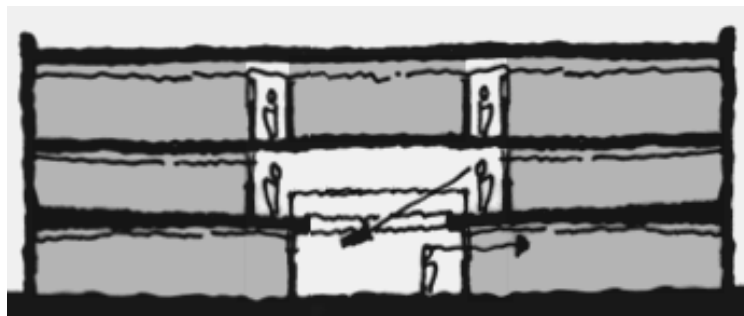
The Torpedo Factory consists of three floors. On the first two, an open atrium space promotes interaction and allows views between the floors. Artists on the third floor have the most privacy; however this studio is not ideal because it becomes more of a destination for visitors. They must seek them out, since views are minimal from one gallery to the next.



**Figure 71: First and Second Floor Atrium Space**



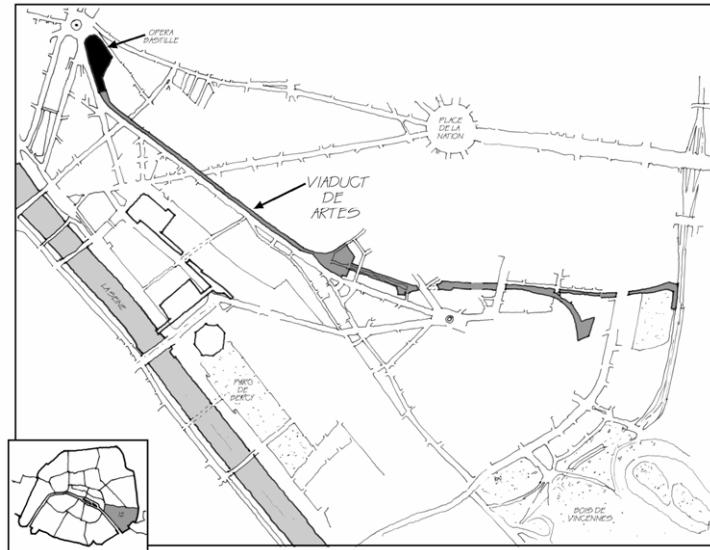
**Figure 72: Third Floor Studios**



**Figure 73: Section through Torpedo Factory**

## VIADUCT DES ARTES

In 1853 a 17-kilometer train line was built for Paris as part of Georges Eugene Haussmann's plans for the city. The line linked the Bois de Vincennes, a park on the eastern edge, to the Place de la Bastille. However, new metro service and train routes in Paris replaced the need for the train



**Figure 74: Map of 12<sup>th</sup> Arrondissement showing location of Viaduct de Artes**

line by 1969. The train line remained deserted for the following three decades.<sup>28</sup>



**Figure 75: Railroad viaduct with garden on top. [Amelar 138]**

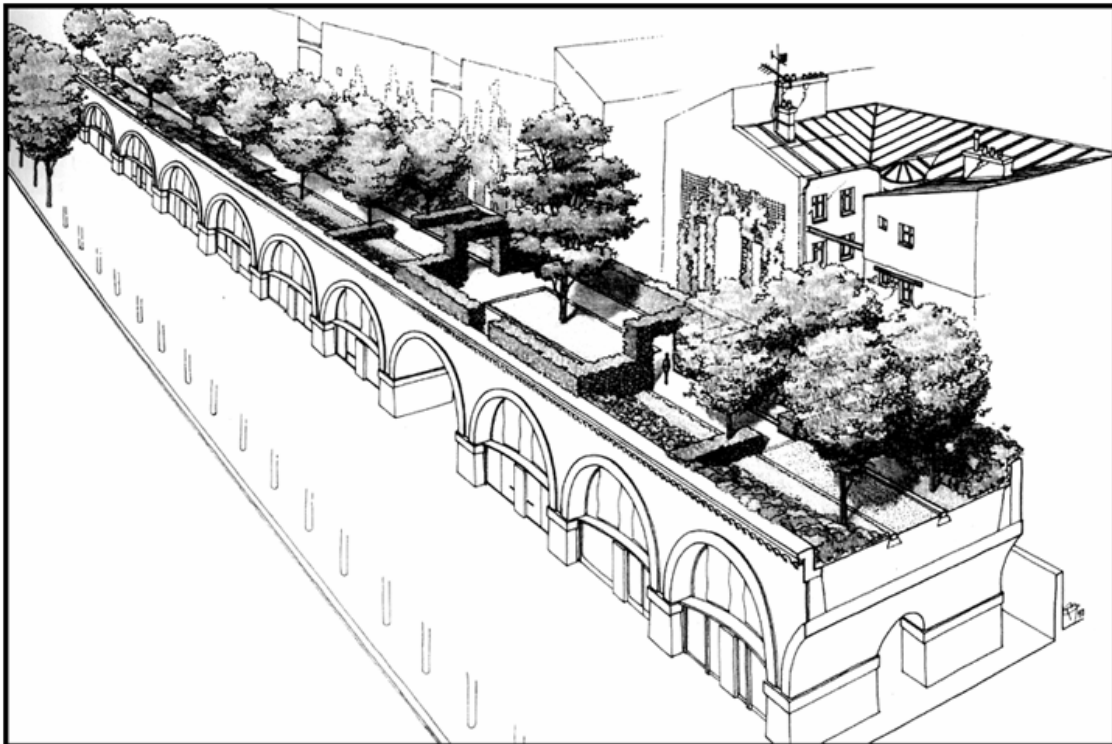
In 1987 a plan was enacted to reuse much of the existing railway, including the viaduct, tunnel, embankments, and trenches. A promenade along the top of the viaduct would become heavily planted to form a linear park system in the city. Architect Philippe Mathieux and landscape architect Jacques Vergely designed the promenade as a way to remove pedestrian traffic off the ground plane and form a stretch of green space weaving through the city fabric.<sup>29</sup>

<sup>28</sup> Bastille, 70.

<sup>29</sup> Amelar, 138.

A competition was held to determine how the viaduct would be renovated on the ground floor. Architect Patrick Berger won the commission and has experience working in historical contexts and relating architecture and landscape.

The viaduct originally consisted of an open arcade at street level. In the three decades after the decline of the rail line, most of the 67 vaults became occupied by a disorderly collection of enterprises. Auto repair, electronic shops, and other haphazard tenants occupied the spaces. Competition officials evaluated the potential of each. Existing tenants were replaced with artisans practicing traditional crafts such as bookbinding, cabinetmaking, and furniture design. Only one tenant, a café would stay in its current location. The resultant viaduct would consist of one artisan per vaulted space, forming the “Viaduct of the Arts.”<sup>30</sup>

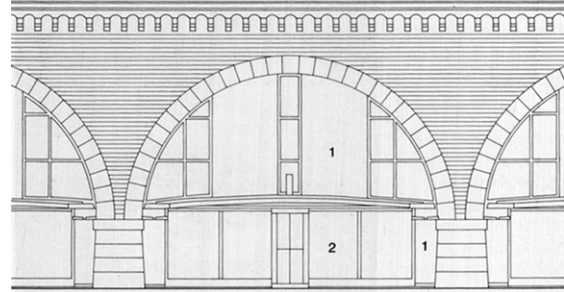


**Figure 76: Isometric, Part of the Viaduct. [Viaduc 75]**

---

<sup>30</sup> Amelar, 138.

Berger's guiding principle in the process of the design was the "expression of this beautiful tectonic shape, the great form of the vaults."<sup>31</sup> His attitude towards the historic preservation of the viaduct was that of a simplistic architectural language,



**Figure 77: Drawing of standard arch on viaduct. [Viaduc 75]**

focusing on the details and recalling the past. To promote the original clean lines of the viaduct, the arcade remains unified, allowing flexibility of storefronts. Top transoms and side window panels are prefabricated, and consistent with each arch. However, the central panel can be manipulated and designed based on the needs and desires of the given artisan.<sup>32</sup>

Transparency of the public façade was desired, to emphasize the original open vaults that existed. The bottom portion of the arches is set in from the front façade wall to create a sense of depth. The arched transom above is set almost two feet behind the lower portion, forming deep shadows on the glass. By recessing the top portion of glass more than the bottom portion, the idea of an open arcade is maintained while maximizing floor space.<sup>33</sup>



**Figure 78: Photo of storefront, showing setbacks of glass. [Amelar 141]**

---

<sup>31</sup> Amelar, 138.

<sup>32</sup> Amelar, 140.

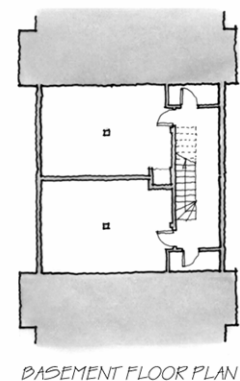
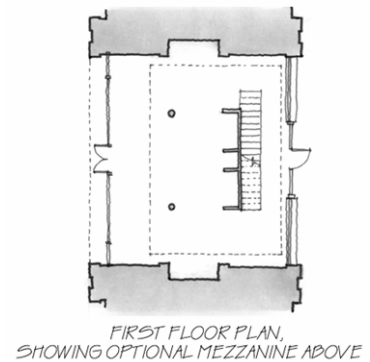
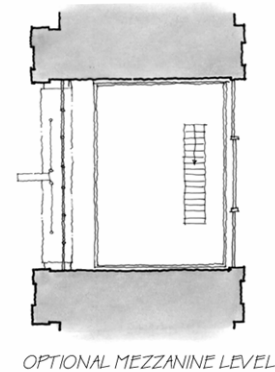
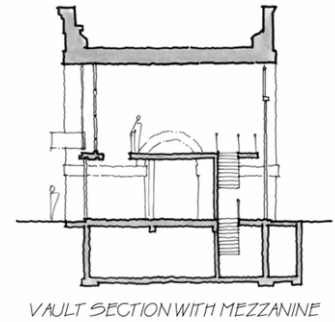
<sup>33</sup> Amelar, 140.

The interior of the vaults are designed to be flexible for different types of artists. A basement level increases the usability of the vaults, and can be used for storage or additional work space. An optional mezzanine level provides additional display space as needed for the artist. Therefore although the arches have a uniform appearance, the spaces within can be tailored as needed.

The resulting Viaduct of the Arts has created a public amenity of the park, while assisting in the rehabilitation of the Bastille neighborhood. Rather than placing upscale businesses in the vaults, artists bring a different and new life to the area.



**Figure 79: Artist working within vaulted space; note daylight pouring in transoms. [Amelar 142]**

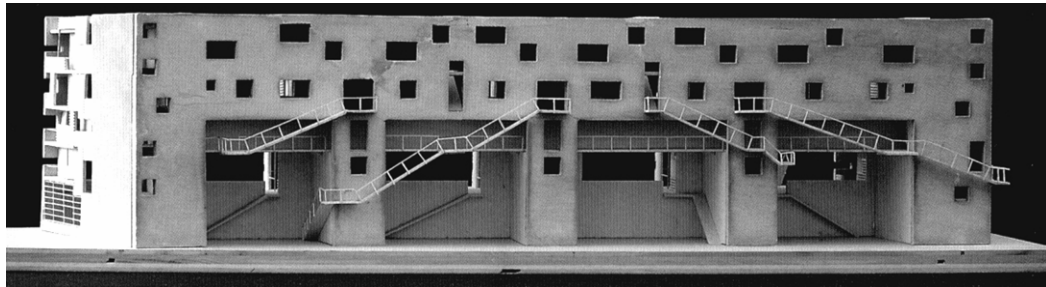


**Figure 80: Section and floor plans of vaulted interiors.**

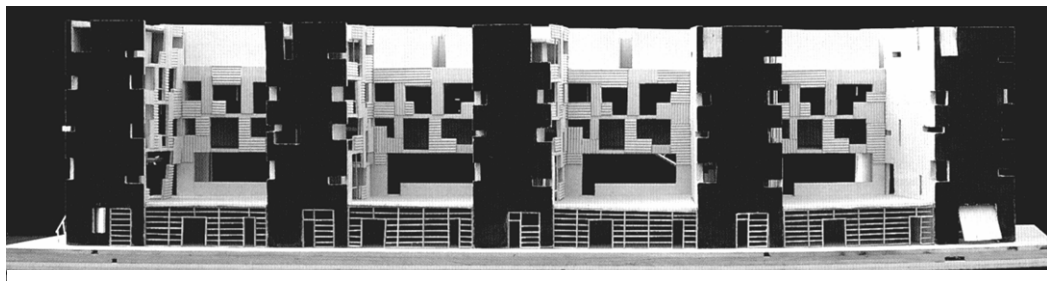
## HOUSING

### FUKUOKA HOUSING: Void Space/Hinged Space Housing in Fukuoka

The Fukuoka Housing, by Steven Holl, is located in Fukuoka, Japan. Rather than creating an object building, Holl seeks to form spaces through the harmonious balance of solids and voids. Four active north facing voids contrast the four quiet south facing voids. The northern edge of the building is lined with shops, to transition from the urban realm to the private spaces within.



**Figure 81: Model of South (Private) Façade. [Holl 99]**



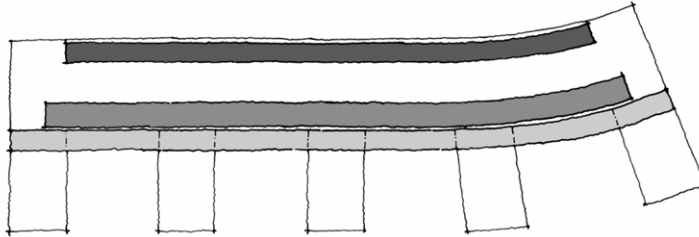
**Figure 82: Model of North (Public) Façade. Note that courtyard starts at the second level on public side. [Holl 99]**

Procession through the building becomes an important component of the design. There are three main passages, which provide exterior access to each apartment. The lower passage runs through the center of the building, visually linking the voids to the north and

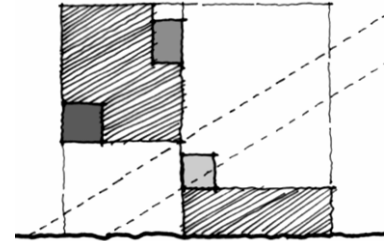


**Figure 83: View of North façade [Holl 95]**

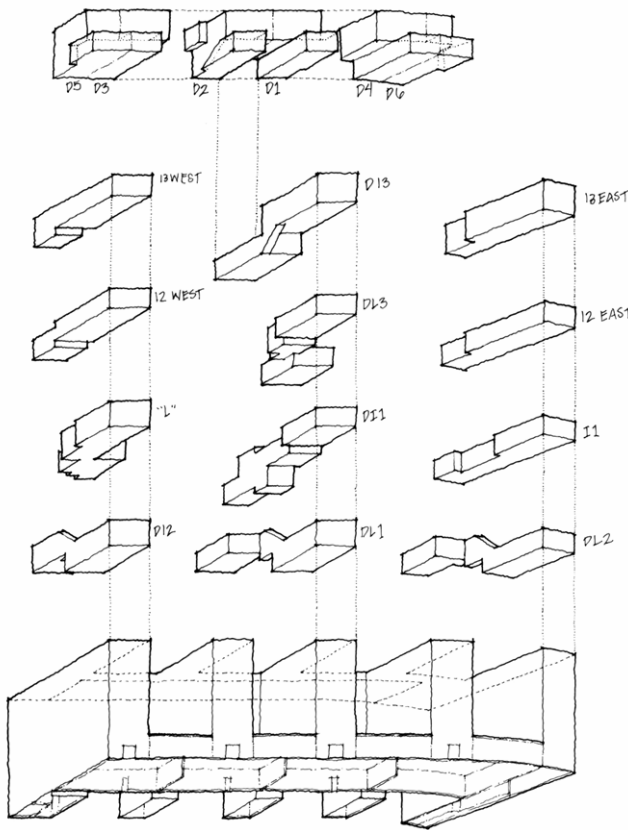
south. The northern passage gives the user a feeling of being suspended into the nearby park. A view to the sky defines the upper most passage, under direct sunlight.<sup>34</sup>



**Figure 84: Diagrammatic Plan showing 3 passages through building.**



**Figure 85: Diagrammatic Section showing 3 passages through building.**



**Figure 86: Interlock of Unit Types [Author's drawing, based on Holl 106]**

Twenty eight apartment units interlock in section like a complex Chinese box.<sup>35</sup> There are 18 variations of the five types of plans: “L” (L-shaped plan), “I” (straight plan), “D” (double level), “DI,” and “DL.” The units interconnect both in plan and section, linking the court spaces on the north and south.<sup>36</sup> The complex connection of the different unit types provides each with multiple exposures of north, south, east, and west light. Each unit is unique in its layout and relationship

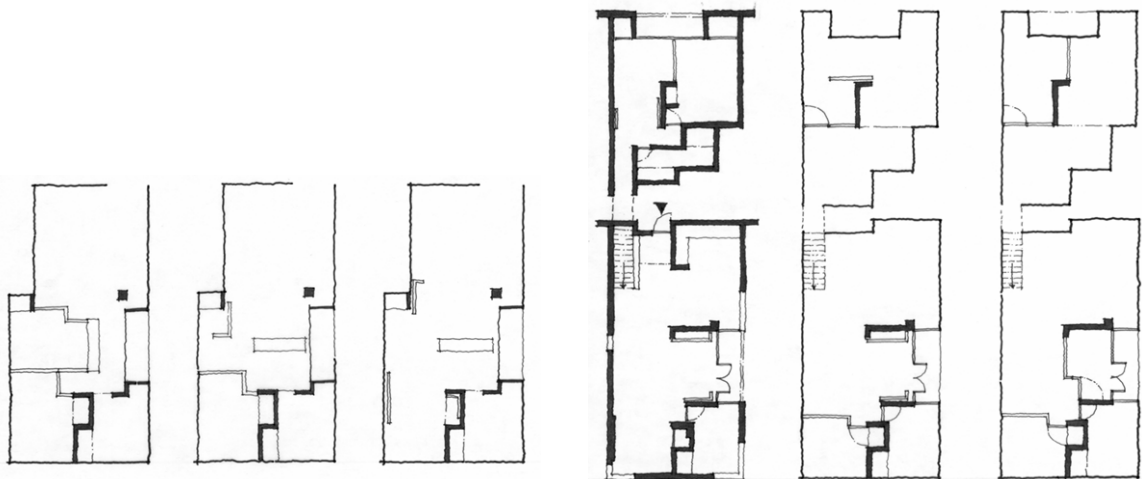
<sup>34</sup> Holl, 94.

<sup>35</sup> Holl, 94.

<sup>36</sup> Holl, 106.

of spaces.<sup>37</sup>

However, all units within the building focus on Holl's idea of "hinged space." The use of pivoting doors, panels, and cabinets makes the units easily adjustable due to *diurnal* and *episodic* changes. *Diurnal* changes reflect the need for living spaces to adjust over the course of a day. Living areas can be expanded during the daylight hours, while bedroom areas become the focus at night. *Episodic* changes relate to the shifting needs of a family over time.<sup>38</sup> For instance, rooms can be added or subtracted as new family members are brought into the family or aged children move out on their own. The adaptability of the units provides users with a unique opportunity to stay in one place of residence as lifestyles change.



**Figure 87: 3 different configurations of one unit plan (2 sets). [Author's drawing, based on Holl 106]**

Holl's implementation of Void Space/Hinged Space forms creative spaces on both the interior and the exterior. The balance between the two creates a building that can easily adapt to the needs of its user while providing significant exterior spaces.

---

<sup>37</sup> Holl, 94.

<sup>38</sup> Holl, 94.



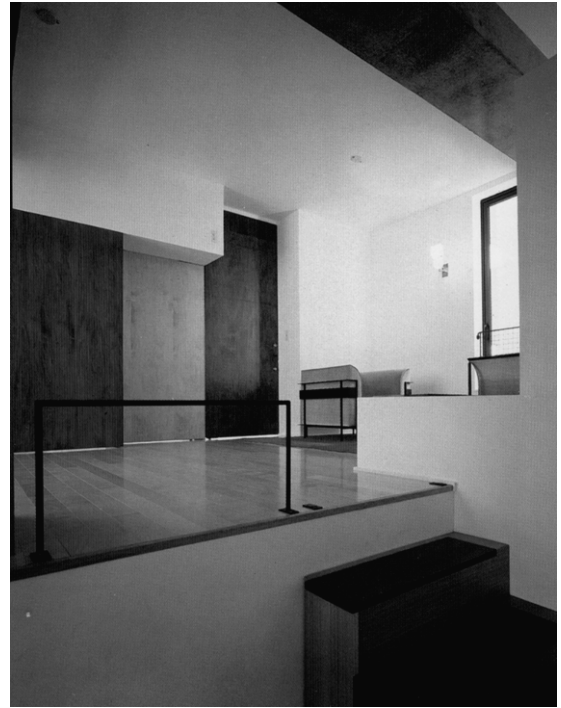
**Figure 88: Interior of Unit, Configured with panels open. [Holl 107]**



**Figure 89: Interior of Unit, Configured with panels closed. [Holl 107]**



**Figure 90: Interior of Unit, Configured with panels open. [Holl 106]**



**Figure 91: Interior of Unit, Configured with panels closed. [Holl 106]**

## MOUNT RAINIER ARTISTS' HOUSING

The Mount Rainer Artists' Lofts will be the first of four new buildings in the Gateway Arts District of Prince George's County, Maryland. Forty-four live/work units will be provided for artists, as well as 7,000 square feet of commercial space to be leased to community-oriented artists.<sup>39</sup> The building will be the entrance to the new arts district, creating a node of art related activity.



Figure 92: Exterior model of building. [HGA Website]

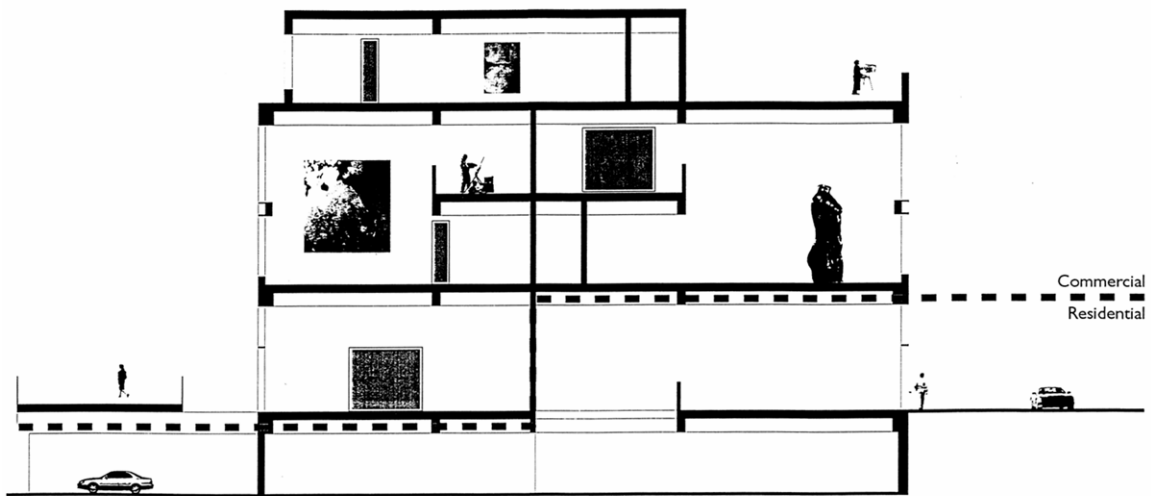
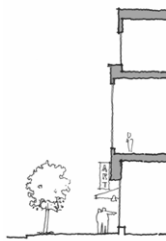


Figure 93: Schematic Section through building. [Courtesy HGA]

<sup>39</sup> [http://www.artspaceusa.org/inprogress/rainier\\_gateway/index.html](http://www.artspaceusa.org/inprogress/rainier_gateway/index.html)

Transparency of the first floor greatly contrasts with those above, where private artist studios and lofts are located. The street level is activated through the articulation of the façade, embracing the public realm. One can clearly see into the gallery space when passing by, prompting interest and engaging the public.

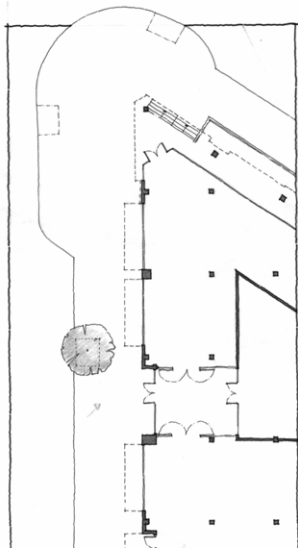
Each unit within the building will have its own amenity. Loft apartments have the luxury of multi-story space, while efficiencies and flats provide outdoor garden space. Sections of the units interlock so corridors are needed on only two of the four levels, maximizing living space.<sup>40</sup>



**Figure 94: Section – Public Side**



**Figure 95: Interior of Unit. [HGA Website]**



**Figure 96: Plan Detail – Public Side**



**Figure 97: Partial Elevation - Public Side**

<sup>40</sup> Mount Rainer literature



**Figure 98: Study of programmable wall elements within units.**

The use of programmable wall elements creates flexible units for different types of artists. Units are designed to be adaptable for the changing working, living, and exhibition needs of the artist. Therefore, the movable structures not only become useful for programmatic reasons, but they can also be used to define and adjust space as needed. Dwellings are designed to be 50 percent larger than typical affordable housing units to increase their flexibility.

Mount Rainer Artists Lofts was awarded \$8 million dollars of federal tax credits by the Maryland Department of Housing and Community Development in January 2002.<sup>41</sup> Other sources of financing are currently being obtained to provide the necessary budget to begin construction in the summer of 2003. The project is estimated to be completed in the fall of 2004.

<sup>41</sup> [http://www.artspaceusa.org/inprogress/rainier\\_gateway/index.html](http://www.artspaceusa.org/inprogress/rainier_gateway/index.html)

## THEORY

Christian Norberg-Schultz reintroduces the Roman idea of *genius loci*, in *The Phenomenon of Place*. *Genius loci* refers to the “spirit of the place.” He states, “Phenomenology’s potential in architecture [is] the ability to make the environment meaningful through the creation of specific places.”<sup>42</sup> Therefore without a sense of place, spaces become insignificant and parallel.

Lawrence Durrell makes a similar argument while referring to the everyday experience of a given place. He says, “As you get to know Europe, slowly tasting the wines, cheeses, and characters of the different countries you begin to realize that the important determinant of any culture is after all – the spirit of the place.”<sup>43</sup> Therefore the spirit of the place does not have to be dominant; it can be part of the culture and texture of the city.

Kevin Lynch, in *The Image of the City*, discusses “paths, edges, districts, nodes, and landmarks as elements of urban planning.”<sup>44</sup> He describes these physical forms as systems of orientation with which a city should be made. Lynch writes, “A good environmental image gives its possessor an important sense of emotional security.”<sup>45</sup> The system of these five planning principles makes a city memorable. People visually connect the elements in their mind, creating an image of the city for them to remember.

The idea of place within the city can be defined by object and texture. For instance, Lynch’s reference to the landmark discusses how it helps to orient people within

---

<sup>42</sup> Nesbitt, 412.

<sup>43</sup> Nesbitt, 423.

<sup>44</sup> Lynch, 46.

<sup>45</sup> Lynch, 4.

the city. An object that stands out within the city fabric brings attention to it and helps the user to associate with his surroundings.

The Arch de Triomphe in Paris, France, acts as a landmark within its surroundings. It helps people associate with where they are, creating an imageable picture in their minds. The avenues radiating from the Place de Charles de Gaulle create



**Figure 99: View from roof of arch**



**Figure 100: View to arch**

numerous visual links to the arch. From a distance, the vision of the arch dominates the area. Another memory is created from the vista from its roof. Views down the avenues orient the viewer within Paris, while highlighting other landmarks within the city.

On a more intimate scale, the Dupont Circle fountain, in Washington, D.C., exemplifies the idea of place. Although visual links are not as prominent, the landmark is evident from within the circle. The fountain is a place people can meet at within the city fabric and relax. This contrasts the Arch de Triumph, which



**Figure 101: Artist drawing fountain @ Dupont Circle. [D.C. Stock Photos]**

defines the ‘place’ more visually than experientially. The fountain creates a landmark within the fabric of Washington, D.C.

The texture of the city fabric can help define a place without bringing attention to any one specific landmark or node. For example, Madrid, in Spain, has many different types of city streets.

Narrow medieval streets define the old part of the city with strait wide boulevards defining the new edges. In the older portion, it is the circumstantial urban fabric that characterizes the place.

Memory associated with Madrid can often consist of just the city streets alone.



**Figure 102: City street of Madrid**

Bringing art into the community also adds to its imageability. In *The Power of Place*, Dolores Hayden develops this idea through the discussion of place and memory. There is not only the visual memory of an individual, but also the social memory through his interactions. Artists have potential to engage the public, helping to create the social identity of a community. Hayden argues that artwork can propose discussion and debate, thus blending it into the experience of the community.<sup>46</sup>

The Place de la Terte in Paris, France, brings the public together, acting as a destination point within the city. The space is surrounded by restaurants and cafes, while

---

<sup>46</sup> Hayden

within the square art work is on display for viewing and purchase. Artists paint and draw in various mediums, while onlookers peer over their shoulders. The space becomes an area of interaction between the everyday person and the artists, a place which attracts people from a mixture of backgrounds. The artistic experience within the space is what makes it memorable.



**Figure 103: Artists and pedestrians in the Place de la Terte.**

Las Ramblas, in Barcelona, Spain has numerous street performers. The architecture along the street is quite interesting and aesthetically appealing, but the memory of the place is more about the experience of the promenade. Interaction of the performers and the pedestrians defines the image of the place.



**Figure 104: Views of Las Ramblas (L to R: Street Performer, Pedestrian Promenade, Street Performer).**

By elevating people's sense of place, people will be more likely to inhabit the public realm. Currently the 14<sup>th</sup> Street area is lacking the sense of place it once had, and through revitalization it can gain that experience back. This thesis will seek to reinstate the imageability, sense of place, and diversity that the area had prior to the 1968 riots.

## **PROGRAM**

### DESIGN OBJECTIVES:

- To promote the area as a cultural and artistic center, using the existing Studio Theatre as a foundation;
- To create a sense of community between artists by providing shared studio and gallery spaces, with living above;
- To respect the existing context of buildings along 14<sup>th</sup> Street by preserving their character and keeping the scale of new construction consistent with existing structures;
- To preserve existing historic structures on site;
- To create mixed uses for residents;
- To provide adequate parking in such a way that does not overwhelm the site;
- To incorporate green space into living units through the use of roof gardens as a secondary ground plane;
- To establish community within the larger context of the city;
- To provide flexible space for artists;
- To maintain diversity of area by not simply creating market value residences but catering towards the artistic community through creative financing and subsidized housing;
- To promote pockets of cultural growth throughout Washington D.C.

Mount Rainer	Brentwood	Hyattsville
75,000 SF	88,000 SF	97,000 SF
44 live/work studios	46 live/work studios	58 live/work studios
1 <sup>st</sup> floor commercial space	1 <sup>st</sup> floor commercial and/or community arts center	1 <sup>st</sup> floor commercial space

**Table 1: Statistics of Three Artist's Live/Work Housing projects. [Artspace, Inc. Website]**

## PRIVATE PROGRAM REQUIREMENTS

The number of dwelling units will be explored through density and massing studies on the site. Units should relate to studio work space in an effort to create a live/work environment, without isolating artists from one another. According to Artspace, Inc., units for artists should be 50 percent larger than standard dwelling units, to account for work space and storage of supplies. Units will be flexible to accommodate different types of artists, although some dwellings may be more specialized. Each unit will include private outdoor space.

- Dwelling Units:<sup>47</sup>
  - Efficiencies: 825-930 s.f./unit
  - One Bedroom Flats: 1150-1390 s.f./unit
  - One Bedroom Lofts: 1400-1517 s.f./unit
  - Two Bedroom Lofts: 1723-1830 s.f./unit
  - Family Lofts: 2525-2630 s.f./unit
- Outdoor Space Per Unit
  - Efficiencies: 150-175 s.f./unit
  - One Bedroom Units: 200-250 s.f./unit
  - Two Bedroom Units: 250-275s.f./unit

---

<sup>47</sup> Square Footages for Units based on Mount Rainer

- Family Units: 300-325 s.f./unit
- Parking (subterranean):
  - .5 space per unit @ 180 s.f. per space

## PUBLIC PROGRAM REQUIREMENTS

The first floor of the art center will incorporate uses to bring in the public, promoting their interaction with the artists. Spaces within the buildings are to be flexible, to accommodate collections of different artists and different types of display.

- Art Galleries:
  - Main Gallery 1600-2000 s.f.
  - Adjacent Film Room 600-750 s.f.
  - 2 Support Galleries 600-775 s.f.
- Café 1600-1800 s.f.
- Communal Studios series @ 800 s.f./studio
- Cyber Facilities 1000-1400 s.f.

## URBAN REQUIREMENTS – 1500 BLOCK OF 14<sup>TH</sup> STREET

The block is to include services which reach out to greater community, while providing functions for artists living within block. Primarily this will consist of boutique shops & cafes on ground stories with residential units above. Requirements are as follows:

- Approximate ground square footage of block: 85,500 s.f.

- Minus Studio Theatre (16,500) s.f.
- Minus existing building @ 14<sup>th</sup> & Q Streets (6,000) s.f.
- Total ground square footage available for development 63,000 s.f.

The following uses are to be programmed for the block to assist in instituting the arts district. However, they are not the focus for the design of this thesis. Square footages are determinant on infilling within the existing fabric, and the adaptive reuse of existing buildings.

- Art supply store
- Offices w/ day care facility
- Community Sculpture Garden
- Classrooms for artists and residents of the neighborhood
  - Bar/Restaurant

## SCHEMATIC DESIGNS

### PARTI ONE – POCKET PARKS

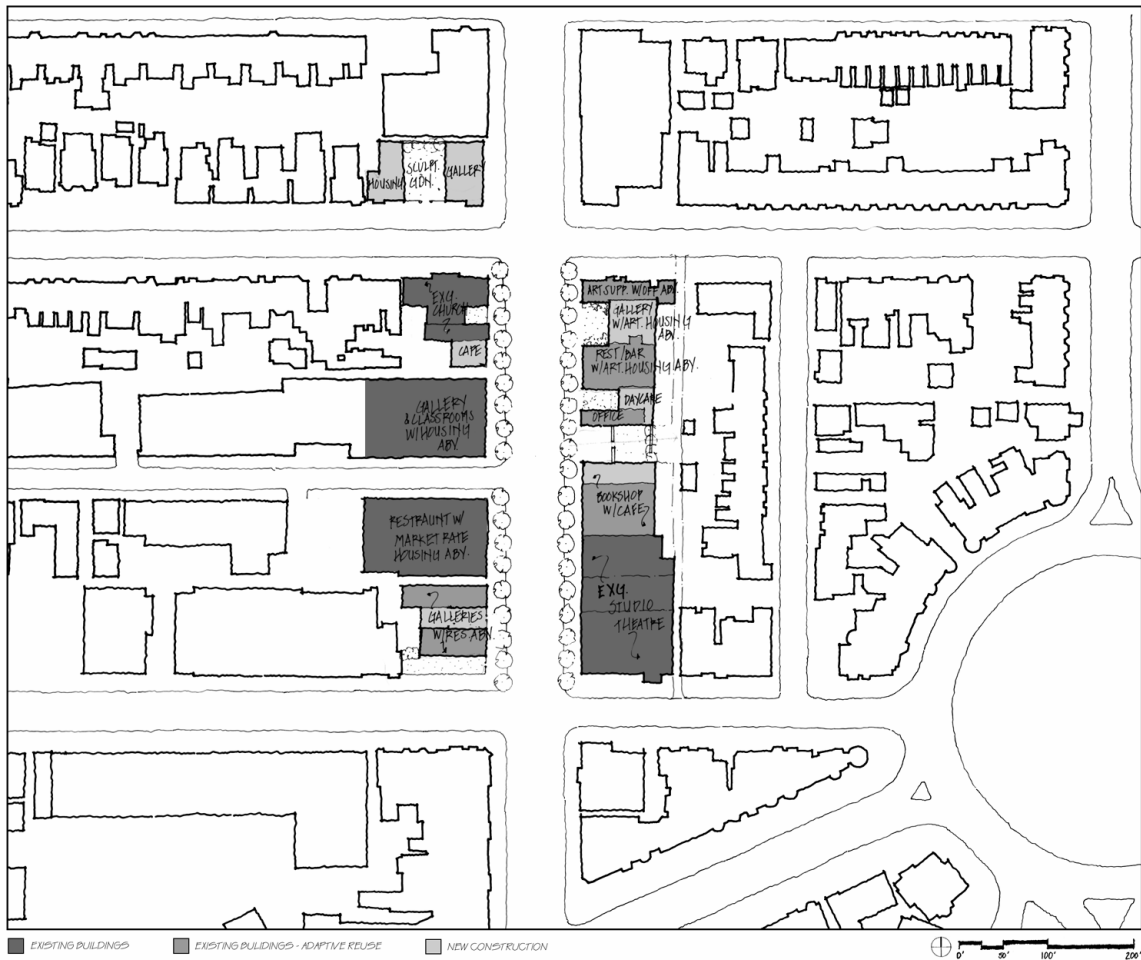


Figure 105: Plan of Pocket Park Parti

Pocket parks are implemented into the block to create special ‘places’ within the city fabric. Dimensions of the parks vary so that each can suit a different purpose or need. The park on axis with Church Street creates potential to provide access to the alley side of the buildings, or the art production side. The park on the northern edge is the largest of all, with potential to serve as a sculpture garden within the community. It is bordered by housing on one side and gallery space on the other. Ideally, as the arts

district grows, the idea of the pocket parks will be maintained through their implementation in the new areas of the artists' community.

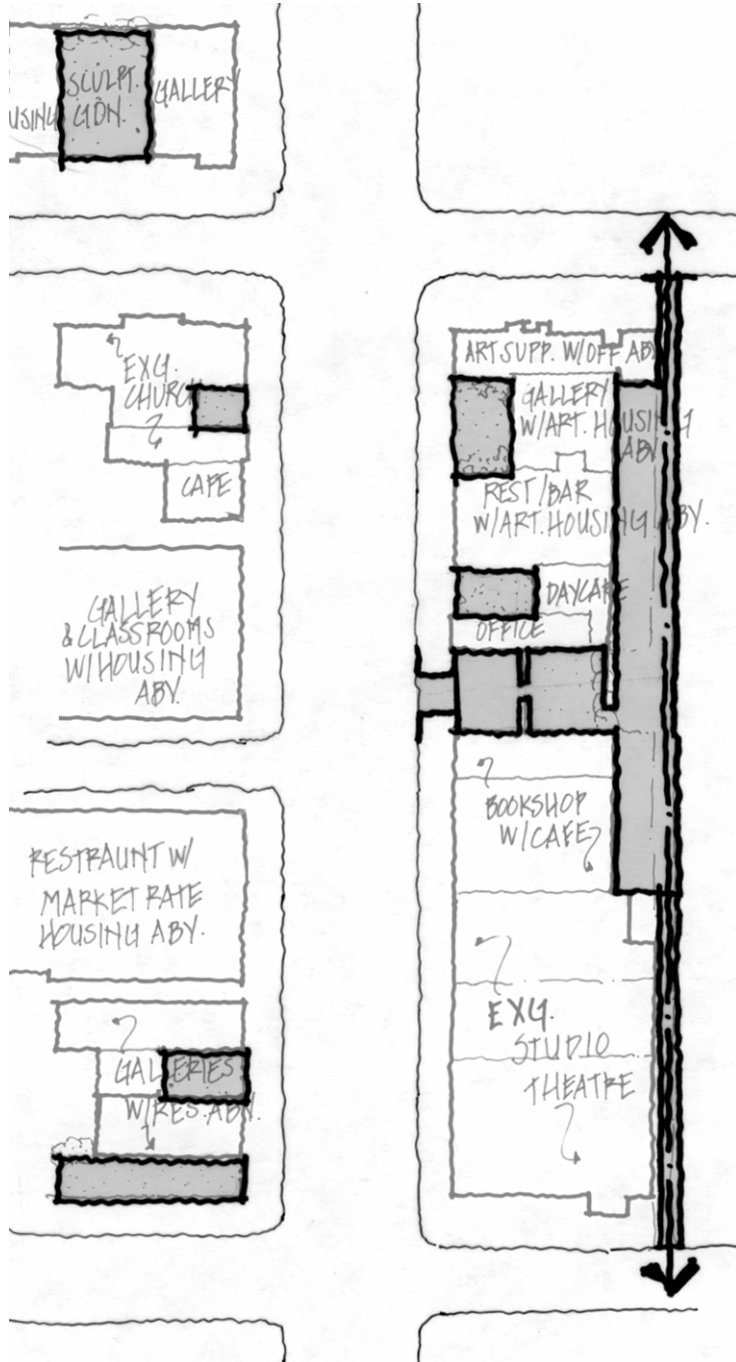
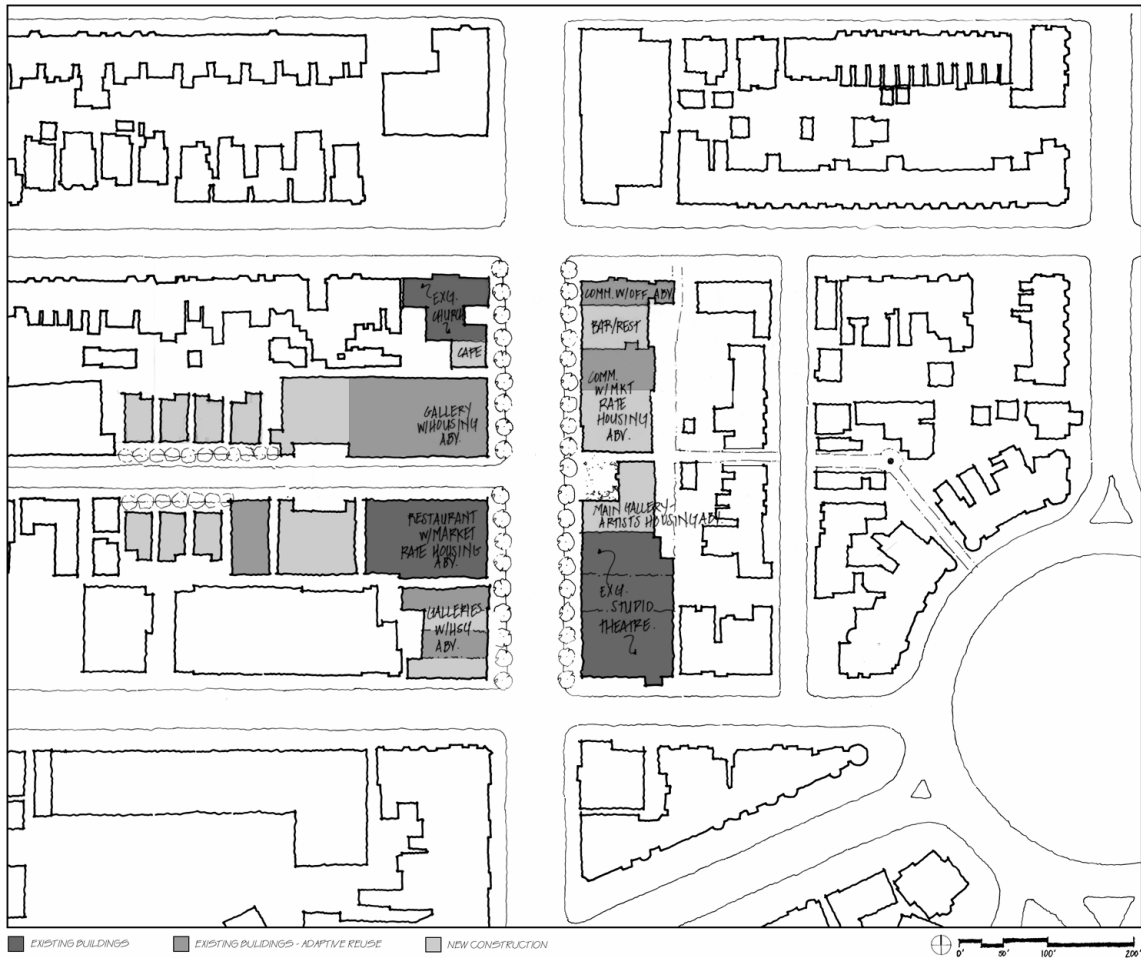


Figure 106: Diagram of Pocket Park Parti

## PARTI TWO – PROMENADE PARTI



**Figure 107: Plan of Promenade Part I**

This scheme incorporates residential units along Church Street for artists to live and work. The buildings are smaller in scale than those on 14<sup>th</sup> Street, and therefore have a much more residential quality to them. They are setback from the sidewalk, but the edge is maintained through landscaping. This provides opportunity for artists to set up outside on a nice day to produce and sell their work. Potentially a nice promenade is set up, running from Church Street all the way to Logan Circle. One would circulate down

Church Street, enter into a park on 14<sup>th</sup> Street, and experience the art production side of the buildings, before moving towards the circle.

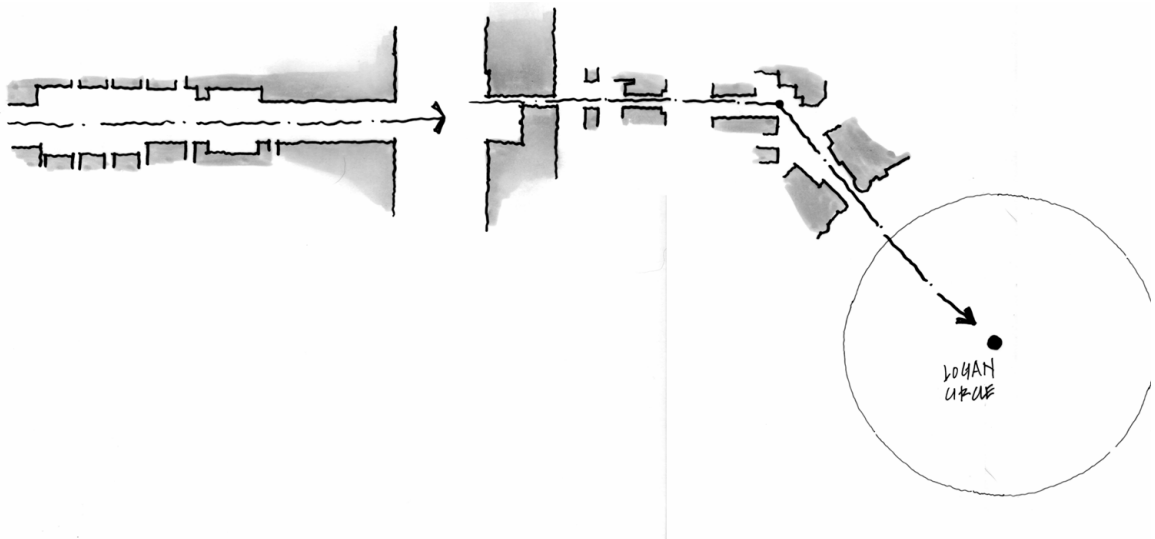


Figure 108: Diagram of Promenade Parti

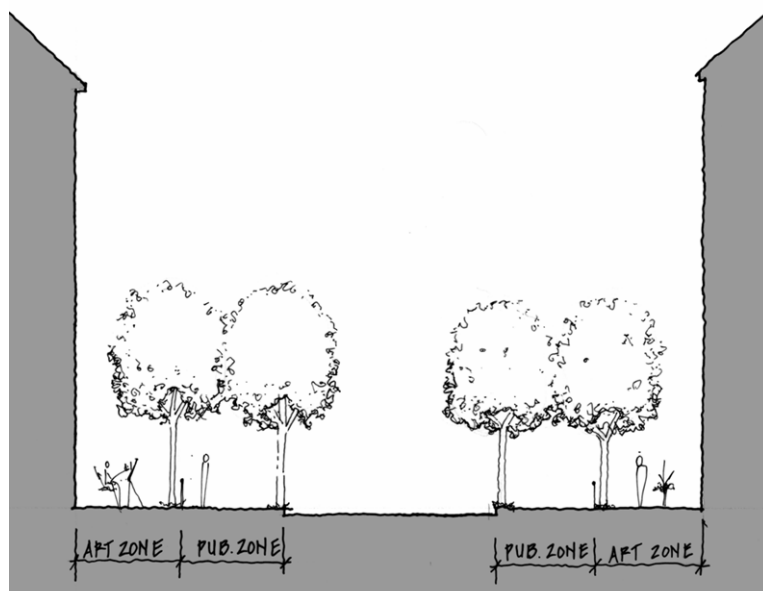
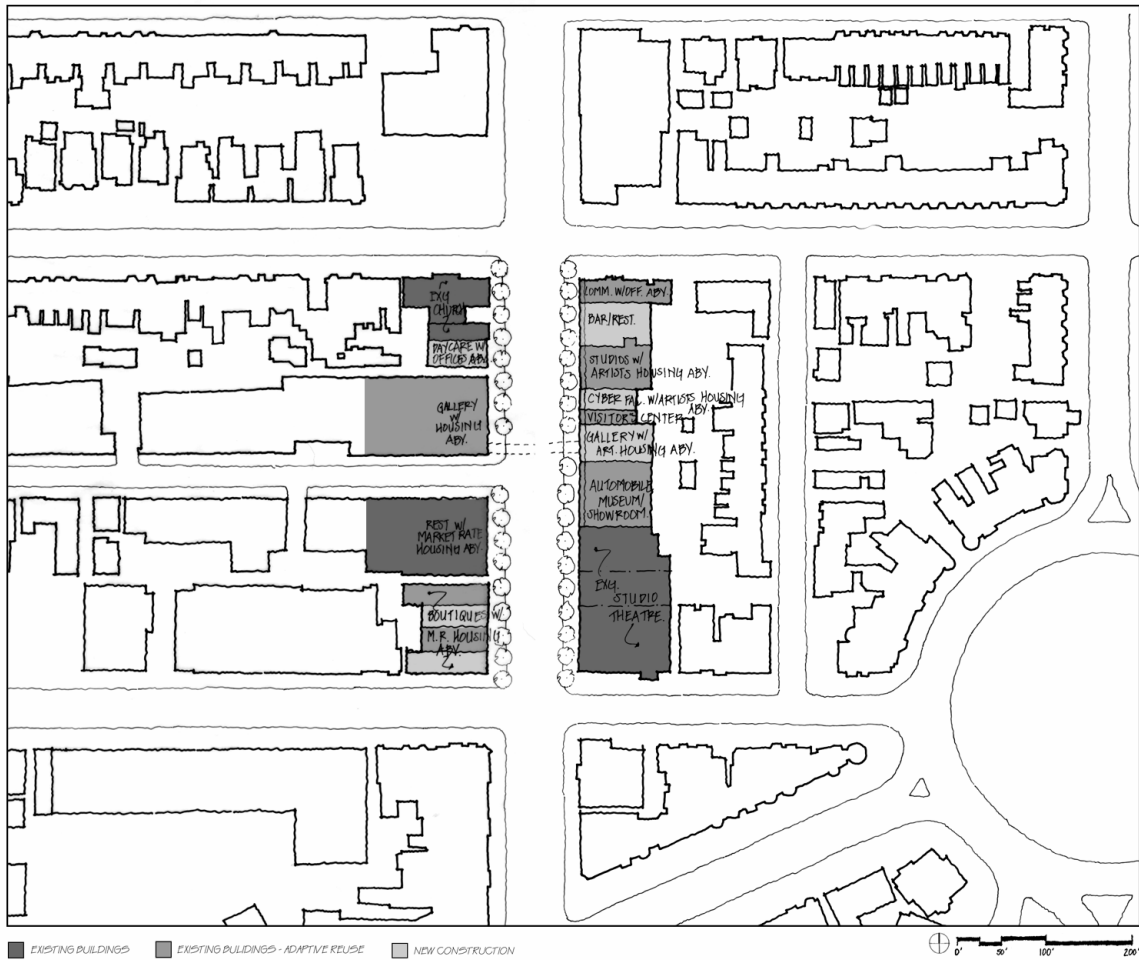


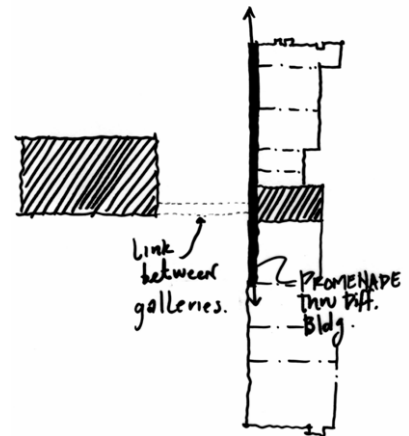
Figure 109: Section through Church Street

### PARTI THREE – “CATWALK PARTI”



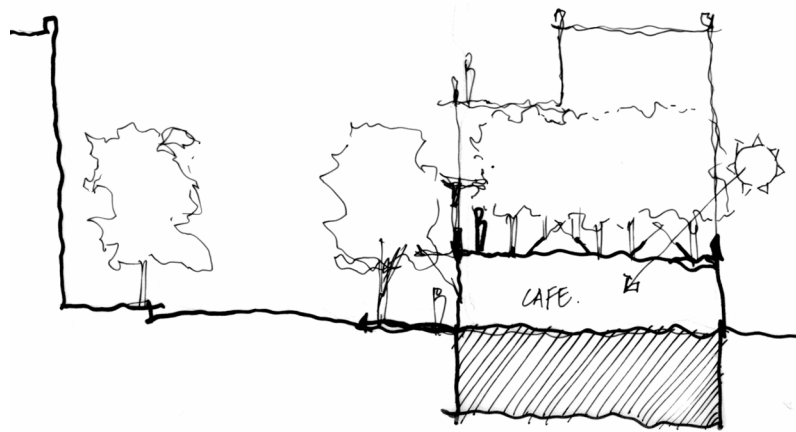
**Figure 110: Plan of ‘Catwalk’ Parti**

In this scheme abandoned buildings are maintained and new ones are filled in. From the exterior, the structures appear separate, but they function as one unit on the interior. A catwalk for residents occurs on the second floor of the buildings, connecting each of them. The experience of the catwalk varies along its length, as it runs through the different buildings. Main gallery buildings are linked by a second

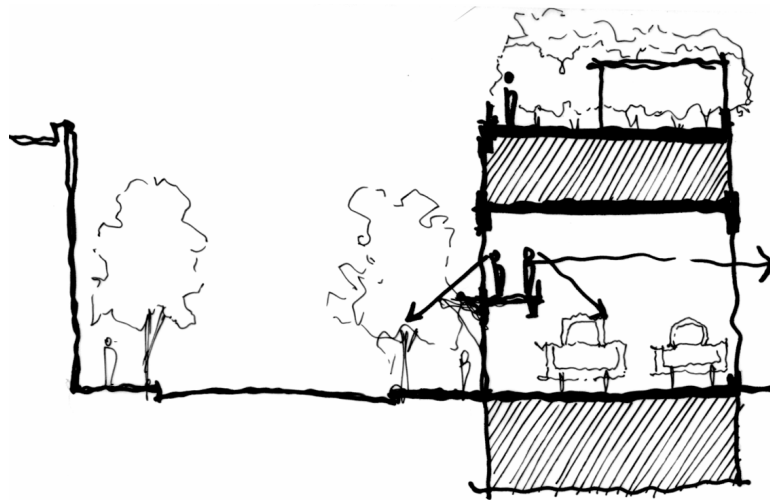


**Figure 111: Diagram of ‘Catwalk’ Parti**

story bridge, which acts as a gateway to the arts district.



**Figure 112: Section through Catwalk @ Cafe**



**Figure 113: Section through Catwalk @ Automobile Museum**

## SCHEMATIC BUILDING SECTIONS

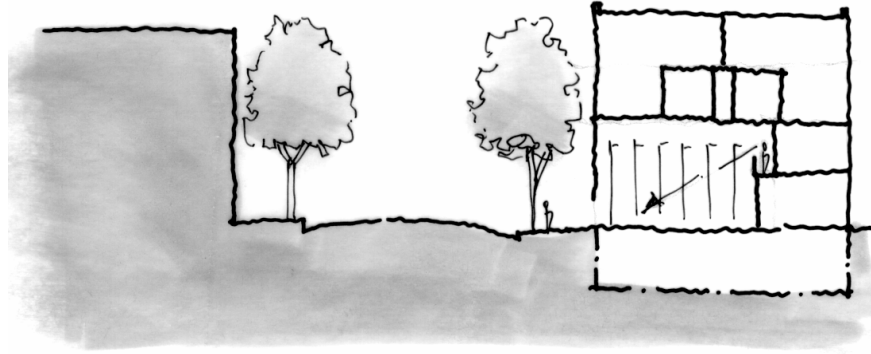


Figure 114: Section showing interaction of gallery space with mezzanine above. Units interlock in section to maximize livable floor area.

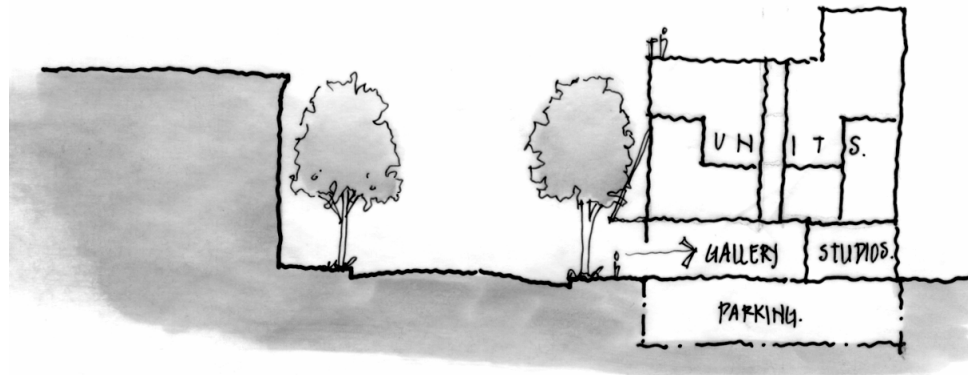


Figure 115: Section showing the two faces of art production: gallery space on the public side, with studio and production space along the alley. Units interlock to gain two-story space into each dwelling. The top floor is set back, providing the amenity of a roof garden.

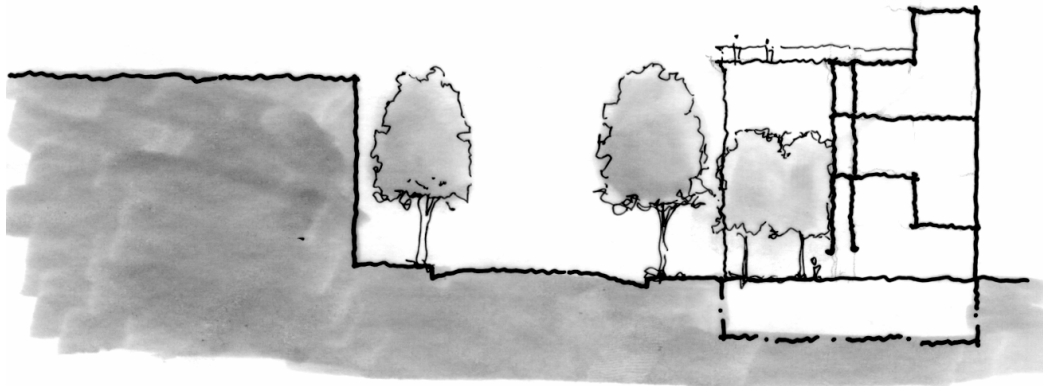


Figure 116: Building section showing opportunity of creating a setback. Space is therefore formed on the public edge for artists to sell their work outside on a nice day. This also shows the potential of a pocket park. The building has more exterior walls due to the setback, resulting in maximum views into the space.

## DESIGN CONCLUSIONS

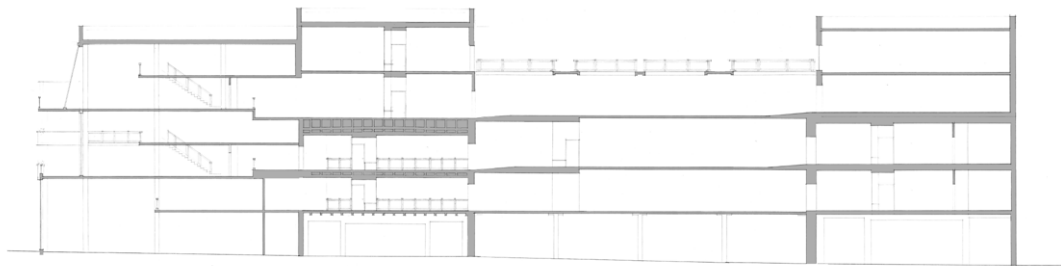
Throughout this thesis the goals for the project have remained consistent, although the scope has transformed. Most importantly, the incorporation of this art center creates an image for the community. In order to do so, there must be a public component that supports the live/work units for the artists. The creation of a contextual art center which also leaves a lasting impression on the visitor has been two objectives for this thesis. To create a beacon for the community, the northwestern corner of the block houses the significant public program. Here, gallery and café space demarcate the corner. The café is designed to operate as its own entity, or to service the gallery during its openings.

The site presented several challenges throughout the semester. Due to its east-west orientation, only the short edge of the structure captures northern light. In an effort to maximize the potential of the north face, two-story units run along that edge. All other units, with 11-14 foot ceiling heights, are oriented to the east and west. The incorporation of existing buildings was also challenging. Several massing studies were executed to study the relationship of new construction with the old automobile showrooms. In order to preserve the integrity of these buildings, new construction on the upper floors is setback from the street. Each of the four structures can be read as separate, while still forming a coherent whole.

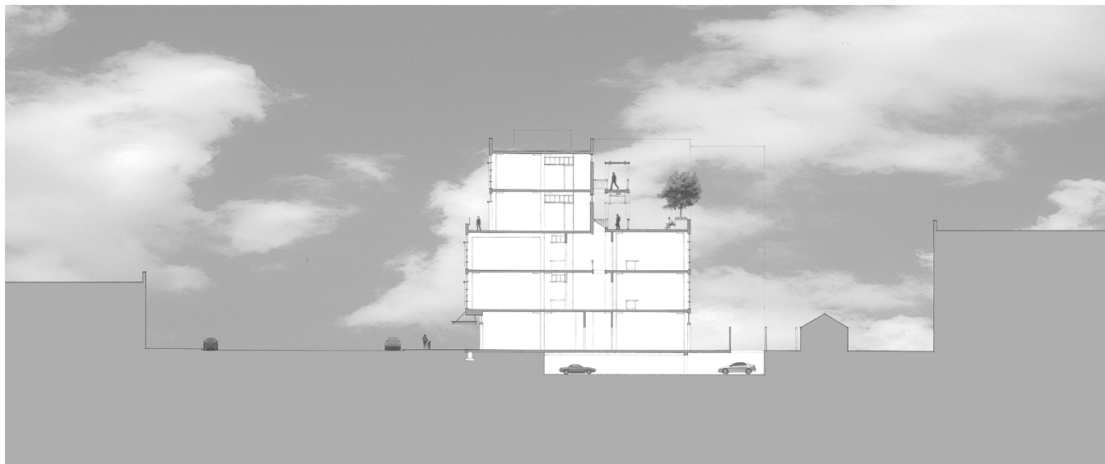
Living units are designed to be flexible for different types of artists. They have the option of placing either their sleeping room or their studio space on the window wall. Spaces are defined by movable panels for optimum flexibility. The only true walls define poche zones and extra bedrooms. The residents are provided the amenity of a roof

garden along the eastern side of the building. Since the artists work within their living quarters, it is a place they can come together for social events and the sharing of ideas.

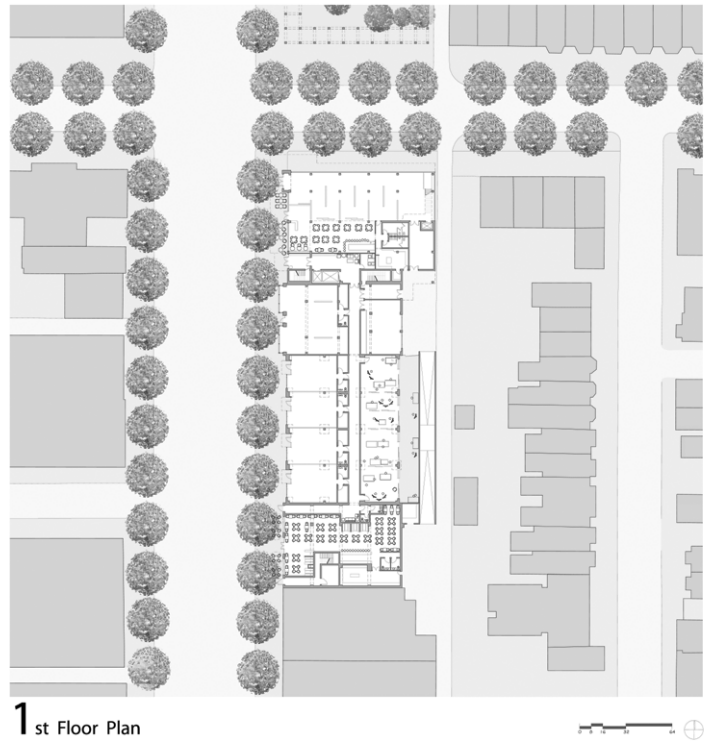
Overall, the Art Center for the Logan Circle Neighborhood provides a positive change for the character of the area. Connecting to the larger community while bringing in a creative population helps give the district an identity. The following drawings illustrate the conclusions of the design:



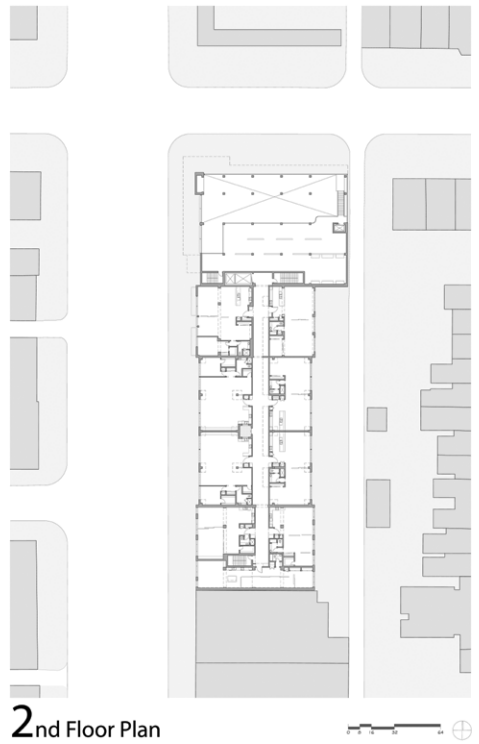
**Figure 117: Section through entire building, including the 2 existing automobile showrooms on site.**



**Figure 118: Cross-section showing relationship of building to 14<sup>th</sup> Street and the roof garden.**



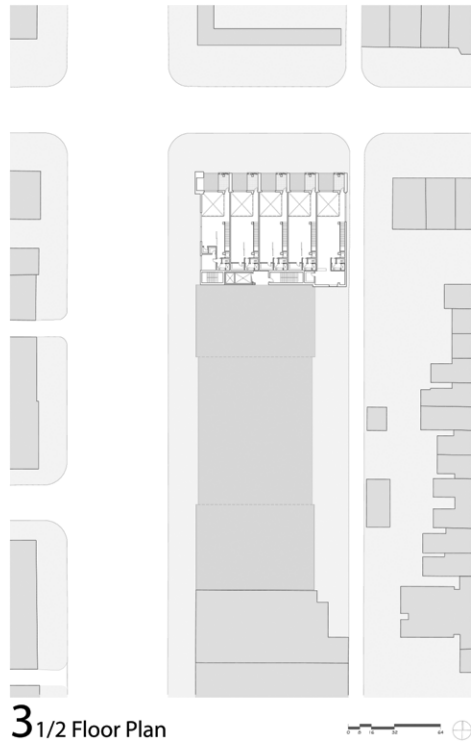
**Figure 119: First floor plan**



**Figure 120: Second floor plan**



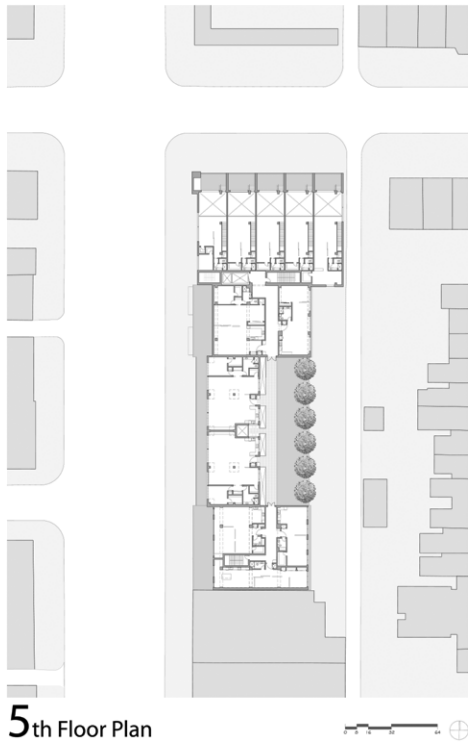
**Figure 121: Third floor plan**



**Figure 122: Plan of floor 3 1/2 (see Figure 116 for floor relationships)**



**Figure 123: Fourth floor plan**



**Figure 124: Fifth floor plan**



UNIT A [Floors 2 & 3]



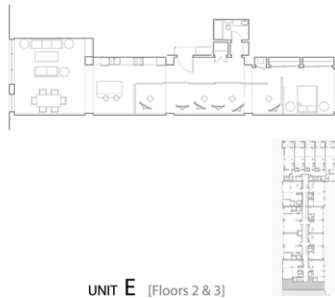
UNIT B [Floors 2 & 3]



UNIT C [Floors 2 & 3]



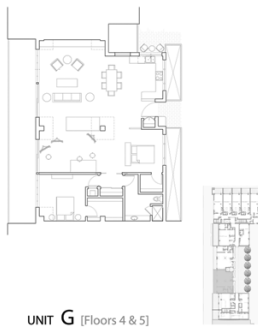
UNIT D [Floors 2 & 3]



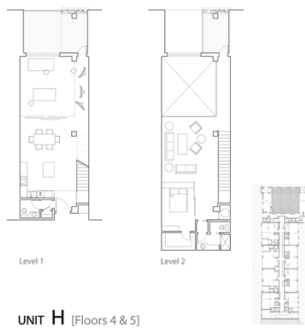
UNIT E [Floors 2 & 3]



UNIT F [Floors 4 & 5]



UNIT G [Floors 4 & 5]



UNIT H [Floors 4 & 5]



UNIT I [Floors 4 & 5]

Figure 125: Unit plans



**Figure 126: West elevation with context**



**Figure 127: West elevation**



**Figure 128: North elevation with context**



**Figure 129: North elevation**



**Figure 130: Perspective of Gallery/Café (Northwest corner)**



**Figure 131: Perspective of main gallery**

## BIBLIOGRAPHY

### SITE:

District of Columbia Municipal Regulations. Chapter 19, Sect. 1900.2

Garvin, Alexander. The American City. Mc-Graw Hill. New York: 1996.

Logan Circle Community Association (LCCA) Website. LCCA. 1 Dec. 2003  
< <http://www.logancircle.org>>.

Historical Society of Washington D.C. The Dupont Circle Historic District. (Pamphlet).  
Washington, D.C.: Tanya Edwards Beauchamp.

Historical Society of Washington D.C. Greater Fourteenth Street and Logan Circle.  
(Pamphlet). Washington, D.C

Historical Society of Washington D.C. Greater U Street Historic District. (Pamphlet).  
Washington, D.C.: Kimberly Prothro Williams.

Project Profiles: The Studio Theatre. Kfoury Construction Group. 22 Dec. 2003.  
<<http://www.kfoury.com/STUDIO.HTM>>

Peets, Elbert. On the Art of Designing Cities: Selected Essays of Elbert Peets. M.I.T.  
Press. Cambridge, Mass.: 1968.

Reiff, Daniel Drake. Washington Architecture 1791-1861. U.S. Commission of Fine  
Arts. Washington, D.C.: 1971.

### PRECEDENTS:

Amelar, Sarah. "From Railway to Greenway." Architecture. April 1997: 138-142.

Artspace. Artspace Projects, Inc. 20 Dec. 2003  
< <http://www.artspaceusa.org/index.html>>

"Bastille Viaduct." Architecture and Urbanism. Nov. 1999: 70-79.

Gateway Arts District Sector Plan and Sectional Map Amendment. Prince George's  
County Planning Department. 22 Dec. 2003  
< <http://www.mncppc.org/cpd/arts.html>>

Holl, Steven. Steven Holl 1986-1996. El Croquis. Madrid: 1996.

The Short North.com. The Short North.com 15 Dec. 2003

The Short North Gazette. The Short North Gazette. 15 Dec. 2003  
<<http://www.shortnorth.com/index.html>>

“Viaduc de la Bastille in Paris.” Detail. July-Aug. 1996: 75-79.

The Torpedo Factory Art Center. The Torpedo Factory. 10 Dec. 2003  
<<http://www.torpedofactory.org>>

#### THEORY:

Chase, John, Margaret Crawford, and John Kaliski. Everyday Urbanism. Monacelli Press. New York: 1999.

Duany, Andres, Elizabeth Plater-Zyberk, and Jeff Speck. Suburban Nation. North Point Press. New York, 2000.

Lynch, Kevin. The Image of the City.

Hayden, Dolores. The Power of Place. MIT Press. Cambridge, Mass.: 1995.

Nesbitt, Kate. Theorizing a New Agenda for Architecture: An Anthology of Architectural Theory 1965-1995. Princeton Architectural Press. New York: 1996.

Washington, DC--Stock Photos. Keith Stanley. 22 Dec. 2003  
<<http://www.kestan.com/dcstock/dupontcircle/>>

#### PROGRAM:

Mount Rainer Literature