

## ABSTRACT

Title of Document: STADSPOORT AMSTERDAM  
Ritsaart Jens Marcelis, M.Arch, 2009

Directed By: Assistant Professor Isaac S. Williams  
School of Architecture, Planning, and Preservation

This thesis will attempt to redevelop the immediate context of Amsterdam's central train station in order to reinvigorate the station's intended purpose of serving as a gateway to the city. Implicit in this goal is the need to examine the transportation and visitor functions housed on the site and to resolve them in a more urbanistically coherent way.

However, the main focus of the thesis is to investigate the history and culture of the city and to synthesize them into a built form which is clearly evocative of Amsterdam's *gestalt*. Since architecture inherently reflects the attitudes of the community that produced it, it is hoped that much of this synthesis may be achieved by examining the tectonic approaches used in Amsterdam's recent and distant architectural past and then reinterpreting them for the twenty-first century.

A secondary focus for the thesis is to attempt to repair the rift in the city's urban fabric that was caused by locating the station at Amsterdam's waterfront, effectively splitting the city in two. Although the primary area of interest is the plaza in front of the station, this secondary focus will necessitate interventions both in the station itself and on its waterfront edge.

By means of these investigations and interventions it is hoped that the site can be reinvigorated as a culturally and urbanistically significant entryway to the city.

STADSPORT AMSTERDAM

By

Ritsaart Jens Marcelis

Thesis submitted to the Faculty of the Graduate School of the  
University of Maryland, College Park, in partial fulfillment  
of the requirements for the degree of  
Master of Architecture  
2009

Advisory Committee:

Isaac S. Williams, Chair

Thomas L. Schumacher, Chair

Karl F. G. DuPuy, Committee Member

Brian P. Kelly, Thesis Coordinator

Filippo Caprioglio, Advisor

Rob van Hees, Advisor

Han Verduin, Advisor

© Copyright by  
Ritsaart Jens Marcelis  
2009

## Foreword

As a child, two things began my interest in architecture: train stations and Gothic architecture. Having already explored the latter in a previous studio, I was interested in pursuing a project that dealt with the architecture of rail. The choice to locate the project in Amsterdam came out of both a desire I had to do a project in my home country of the Netherlands and the deeply personal connection I feel to the city specifically.

Since I moved out of the Netherlands, Amsterdam has been the place where I have spent most of my time when I have gone back to see my family. It is a place that has always caused me to reevaluate my views and attitudes, and has always brought me clarity (perhaps strangely, given its reputation). The choice to work with a train station in Amsterdam is thus highly personal.

I have specifically chosen Amsterdam Centraal Station for this exploration because of its iconic nature for the city and because there are so many opportunities to creatively right the various wrongs that have been committed on the site over the last hundred years. I therefore felt that this station would provide the best opportunities for engaging critical architectural thinking as well as allowing me to pursue my personal interests.

However, insofar as I intend the ultimate design proposal for the site to be reflective of the city and its culture and history, the underlying theme of this thesis is as much about the idea of improving a train station as it is to attempt to provide an examination of Amsterdam itself.

## **Dedication**

This thesis is dedicated to two people: My grandfather, Anne Schotanus, for his indulgence in my childhood interest in going to every train station in Amsterdam and for always encouraging my interests in drawing, architecture, and engineering, and Tom Schumacher, for always providing interesting and stimulating conversations about architecture, and other subjects, and for teaching me how to understand façade design and never to pass judgment on a building until you have been there.

## **Preface**

Photos, drawings, computer models, and other graphics in this document are by the author, except where noted. All satellite map images are copyright-free screenshots from Google Earth and have been manipulated by the author.

## **Acknowledgements**

First and foremost, I thank my parents for providing constant support over the years, emotional, financial, and otherwise. I thank my brother for encouraging my ambitions and giving me a drive to succeed at them.

I thank all my friends and extended family for all the support over the years.

I thank the faculty at the School of Architecture, Planning, and Preservation for making the last seven years consistently interesting, intellectually stimulating, and challenging. I specifically thank Ralph Bennett for always providing me with thoughtful and nuanced guidance in all things academic and professional as well as in life generally.

Lastly, I would like to extend a special thanks to coffee, for providing me with its invaluable support and assistance during all my years in school, and to the Trappist ales of Belgium, for providing me with invaluable support and assistance in enjoying myself when not in school.

# Table of Contents

Foreword.....	ii
Dedication.....	iii
Preface.....	iv
Acknowledgements.....	v
Table of Contents.....	vi
List of Images.....	viii
Chapter 1: Introduction.....	1
On the Use of the Term ‘City Image’.....	1
Statement of the Problem.....	2
Chapter 2: Key Concepts.....	6
Theory.....	6
On Memory.....	6
Preservation?.....	11
Culture.....	15
Architectonic Traditions.....	15
Chapter 3: Site Analysis.....	20
Diagrams.....	20
The Growth of Amsterdam.....	20
The Amstel River.....	23
Transport Functions.....	25
Connections Between Historic Amsterdam and Amsterdam North.....	27
Iconic Buildings and Places.....	28
Programmatic Needs.....	29
Chapter 4: Design Considerations.....	35
Preliminary Explorations.....	35
Program and Parti.....	35

Visual Connectivity with the IJ .....	37
Waterfront Image of the Station .....	45
Station Plaza.....	49
The Station Building .....	50
Chapter 5: Design Process .....	54
Restoring the Connection between the City and the Water .....	54
Developing the Connection through the Station.....	54
The Image of the River in the City .....	61
Developing the Waterfront Area .....	64
Ruyterplein as New Waterfront Plaza .....	64
Connections with the Surrounding Areas.....	68
Further Development Ideas .....	70
Active Gallery .....	72
Performance Space .....	76
Reorganizing the Modes of Transport .....	80
The Transferia .....	80
Language of the Underground.....	88
New Transportation Diagram .....	91
Building on the Image of the Station in the City.....	92
Stationsplein .....	92
Train Sheds.....	94
Station IJzijde .....	97
Before and After .....	108
Chapter 6: Conclusions .....	116
A New Gateway.....	116
Additional Images .....	118
Bibliography .....	131

## List of Images

Figure 1 - Image of Typical Amsterdam Canal .....	1
Figure 2 - Beurs van Berlage .....	15
Figure 3 - Station Amsterdam Sloterdijk.....	15
Figure 4 - Oude Kerk / Old Church .....	16
Figure 5 - Typical Rowhouses.....	16
Figure 6 - Old Waterfront Warehouse / Brick Detailing .....	17
Figure 7 - Lloyd Hotel / Brick Detailing .....	17
Figure 8 - New Waterfront Housing (The Whale).....	18
Figure 9 - ARCAM Building .....	18
Figure 10 - Centraal Station Detail.....	19
Figure 11 - Corner House Along Canal .....	19
Figure 12 - Original River Course and Waterfront .....	20
Figure 13 - Addition of First Canal .....	20
Figure 14 - Addition of Second Canal; Two Canals Mark Oldest Core of City .....	21
Figure 15 - Addition of Service Canals at Dock Areas .....	21
Figure 16 - Planned Growth Via Radial Canal System.....	22
Figure 17 - Completed Canal System with Defensive Outer Ring.....	22
Figure 18 - Axial Connection Between Centraal Station and Dam Square.....	23
Figure 19 - Overlay of Original Course of Amstel River .....	23
Figure 20 - Original Flow of Amstel and Location of Dam .....	24
Figure 21 - Visible Waterfront from City Side Relative to Centraal Station .....	24
Figure 22 - Train .....	25
Figure 23 - Train and Light Rail .....	25
Figure 24 - Train, Light Rail, and Bus.....	26
Figure 25 - Train, Light Rail, Bus, and Bicycle Storage .....	26
Figure 26 - Train, Light Rail, Bus, Bicycle Storage, and Boat Areas.....	27
Figure 27 - Historic Core of Amsterdam and North Amsterdam .....	27

Figure 28 - Key Places in Historic Central Amsterdam.....	28
Figure 29 - Transport Links to Key Places .....	28
Figure 30 - Traffic Parti Diagram .....	35
Figure 31 - Foot Traffic Diagram .....	35
Figure 32 - Programmatic Issues.....	36
Figure 33 - Site Scheme.....	36
Figure 34 - Scheme 1 Plan.....	36
Figure 35 - Aerial View of Centraal Station.....	37
Figure 36 - Strategy 1: Cut Under Station .....	38
Figure 37 - Strategy 2: Go Over Station .....	39
Figure 38 - Strategy 3: Cut Through Station .....	40
Figure 39 - View of Entry Hall with Existing Central Passage.....	41
Figure 40 - View of Existing Central Passage .....	41
Figure 41 - View of Entry Hall with Sky lit Central Passage .....	42
Figure 42 - View of Sky lit Central Passage .....	42
Figure 43 - Diagram of Water Procession from Dam to Station.....	43
Figure 44 - Diagram of Water Procession from Dam to Station.....	44
Figure 45 - Perspective of Water Procession.....	44
Figure 46 - Centraal Station Waterfront Side .....	45
Figure 47 - Schematic Perspective Views with Northern Building .....	46
Figure 48 - Tectonic Reference: Warehouse .....	47
Figure 49 - Tectonic Reference: Warehouse .....	47
Figure 50 - Tectonic Reference: Brick Detailing.....	48
Figure 51 - Tectonic Reference: Muziekgebouw .....	48
Figure 52 - Schematic Drawing of Boat Area .....	49
Figure 53 - Schematic Drawing of Pedestrian Entry to Bus Area.....	49
Figure 54 - Entry Hall Perspective .....	50
Figure 55 - Entry Hall Diagram .....	50
Figure 56 - Schematic Central Passage: Longitudinal Section .....	51

Figure 57 - Schematic Central Passage: Transverse Section.....	51
Figure 58 - Schematic Central Passage: Plan .....	51
Figure 59 - Schematic Central Passage: Isometric View .....	52
Figure 60 - Schematic Central Passage: Perspective Down Hall.....	52
Figure 61 - Schematic Central Passage: View of Track 'Vaults'.....	52
Figure 62 - Comparing a Typical Amsterdam Street Section to a Possible Station Section.....	53
Figure 63 - Current Station as Closed City Gate.....	54
Figure 64 - Desired Condition: Station as Open Gate Leading to the Water.....	55
Figure 65 - Metaphorical River Through Station .....	55
Figure 66 - Existing Station Plan.....	56
Figure 67 - Existing Central Passage .....	56
Figure 68 - Main Strategy: Widen Central Passage and Create Nodes at Both Entry Points .....	57
Figure 69 - Proposed New Station Plan .....	57
Figure 70 - Proposed Passage Section with Daylighting.....	57
Figure 71 - View of Proposed Central Passage .....	58
Figure 72 - Section: Approach from Prins Hendrikkade .....	59
Figure 73 - Section: Station Plaza with Restored Main Hall .....	59
Figure 74 - Section: New Central Passage.....	60
Figure 75 - Section: Waterside Plaza with New Waterside Hall .....	60
Figure 76 - Diagram: Reinforcing the Original Path of the Amstel through Selected Interventions.....	62
Figure 77 - Intervention Area: Beurs van Berlage (Daytime).....	63
Figure 78 - Intervention Area: Beurs van Berlage (Nighttime).....	63
Figure 79 - Existing View of Ruyterkade .....	65
Figure 80 - Section through Ruyterplein.....	65
Figure 81 - View of New Waterfront Station Building (Station IJzijde) .....	66
Figure 82 - Proposed Site Plan .....	66

Figure 83 - Landscape Idea: Market Area at Western Edge of Ruyterplein .....	67
Figure 84 - Landscape Idea: Performance Space at Eastern End of Ruyterplein.....	67
Figure 85 - Landscape Idea: Benches on Ruyterplein .....	67
Figure 86 - Diagram: Disconnection of Urban Development Around Station .....	68
Figure 87 - Warehouse District; Lack of Groundscape .....	68
Figure 88 - Warehouse District; Lack of Groundscape .....	69
Figure 89 - Proposed Diagram: Station as Generator for New Green Edge .....	70
Figure 90 - Expanded Site Plan for Ruyterplein .....	70
Figure 91 - Ruyterplein with Proposed Mixed-Use Buildings at East and West .....	71
Figure 92 - Alternate Development Strategy of Ruyterplein .....	71
Figure 93 - Site Plan for Ruyterplein .....	72
Figure 94 - Plan of Active Gallery .....	73
Figure 95 - Bay Detail of the Active Gallery .....	73
Figure 96 - Modular Boxes .....	74
Figure 97 - Modular Boxes in Gallery Space .....	74
Figure 98 - Modular Boxes used as Platform for Painting .....	75
Figure 99 - Modular Boxes used as Benches .....	75
Figure 100 - Perspective of Active Gallery .....	76
Figure 101 - Site Plan of Ruyterplein .....	76
Figure 102 - Modular Pieces for Performance Area .....	77
Figure 103 - Partition Module Construction Details .....	78
Figure 104 - Partition Module Configuration Options .....	78
Figure 105 - View of Performance Space with Modules .....	79
Figure 106 - View from Performance Space .....	79
Figure 107 - View of Existing Tram Area .....	80
Figure 108 - View of Existing Bus Area.....	81
Figure 109 - View of Existing Bus Area.....	81
Figure 110 - View of Existing Metro Entrance .....	82
Figure 111 - View of Existing Metro Station .....	82

Figure 112 - View of Bicycle Flat .....	83
Figure 113 - Proposed Ground Floor Plan.....	84
Figure 114 - Diagram: Transferia as Node Points at North and South Entrances .....	84
Figure 115 – Transferia .....	85
Figure 116 - Transferium Plan.....	85
Figure 117 - Transferium Plan Superimposed on Ground Floor Plan.....	86
Figure 118 - Section: Transferium A .....	86
Figure 119 - Section: New Metro Station below Main Passage .....	87
Figure 120 - Section: Transferium B.....	87
Figure 121 - View of Entrance/Exit from Transferium A to Stationsplein .....	89
Figure 122 - View of Transferium A .....	89
Figure 123 - View of Transferium B .....	90
Figure 124 - View of Entrance/Exit from Transferium B to Ruyterplein.....	90
Figure 125 - Existing Transportation Diagram .....	91
Figure 126 - Proposed Transportation Diagram .....	91
Figure 127 - Existing View of Stationsplein.....	92
Figure 128 - Site Plan .....	93
Figure 129 - Proposed View of Stationsplein.....	93
Figure 130 - View of Existing Train Shed.....	94
Figure 131 - View of Existing Train Shed.....	95
Figure 132 - View of Proposed Train Shed.....	95
Figure 133 - View of Proposed Train Shed.....	96
Figure 134 - View of Proposed Train Shed.....	96
Figure 135 - View of Proposed Platform Area .....	97
Figure 136 - Existing View of Ruyterkade .....	98
Figure 137 - Station IJzijde: Proposal 1 .....	98
Figure 138 - Station IJzijde: Proposal 2 .....	99
Figure 139 - Station IJzijde: Proposal 3 .....	99
Figure 140 - Station IJzijde: Proposal 4 .....	100

Figure 141 - Station IJzijde: Proposal 5 .....	100
Figure 142 - Proposal 6 .....	101
Figure 143 - Station IJzijde: Proposal 7 .....	101
Figure 144 - Station IJzijde: Proposal 8 .....	102
Figure 145 - Station IJzijde: Proposal 9 .....	102
Figure 146 - Station IJzijde: Proposal 9 .....	103
Figure 147 - Station IJzijde: Final Proposal (Process).....	103
Figure 148 - Station IJzijde: Final Proposal (Process).....	104
Figure 149 - Station IJzijde: Final Proposal .....	104
Figure 150 - Station IJzijde: Sections and Elevations .....	105
Figure 151 - Ground Floor Plan .....	106
Figure 152 - First Floor Plan .....	106
Figure 153 - Second Floor Plan .....	107
Figure 154 - Before: Stationsplein .....	108
Figure 155 - After: Stationsplein .....	108
Figure 156 - Before: Central Passage .....	109
Figure 157 - After: Central Passage.....	109
Figure 158 - Before: Platform Area .....	110
Figure 159 - After: Platform Area .....	110
Figure 160 - Before: Ruyterkade .....	111
Figure 161 - After: Ruyterplein .....	111
Figure 162 - Before: Metro Entrance .....	112
Figure 163 - After: Metro Entrance .....	112
Figure 164 - Before: Metro Station .....	113
Figure 165 - After: Transferium A .....	113
Figure 166 - Before: Bus Depot.....	114
Figure 167 - After: Transferium B .....	114
Figure 168 - Before: Bus Depot.....	115
Figure 169 - After: Transferium B Exit .....	115

Figure 170 - Thesis Match Poster.....	118
Figure 171 - Amsterdam Inner City Aerial Map .....	119
Figure 172 - Site Diagrams and Images.....	120
Figure 173 - Investigations.....	121
Figure 174 - Massing Studies .....	122
Figure 175 - Preservation? .....	123
Figure 176 - Green Spaces, Views, and Scale Comparison of Iconic Buildings.....	124
Figure 177 - Schematic Images .....	125
Figure 178 - Original Station Elevation (West Side).....	126
Figure 179 - Original Station Elevation (East Side) .....	126
Figure 180 - Original Station Rear Elevation .....	126
Figure 181 - Section Through Main Hall .....	127
Figure 182 - Section Through Wings .....	127
Figure 183 - Original Station Ground Floor Plan.....	128
Figure 184 - Renovated Station Ground Floor Plan (1980).....	128
Figure 185 - Original Station First Floor Plan .....	129
Figure 186 - Renovated Station First Floor Plan (1980).....	129
Figure 187 - Etchings of Original Station Interiors.....	130

## Chapter 1: Introduction

### On the Use of the Term ‘City Image’

Within the context of this document, the term ‘city image’ should be taken to mean the city’s *gestalt*, or the collective experience of spaces and places within the city which form in the mind of the visitor (or resident) an image of the city’s culture, mindset, and atmosphere. This includes but is not limited to major spaces, common street images/sections, figural buildings, natural aspects, the way in which buildings are used and maintained, and density. In short, while holistically subjective and impossible to precisely define, there are elements of the city image (such as the ones listed above) which can be examined and responded to in an objective fashion.



Figure 1 - Image of Typical Amsterdam Canal

## **Statement of the Problem**

Amsterdam Centraal Station is the busiest train station in the Netherlands, and is used by about 150,000 passengers per day. It is the central transit hub of Amsterdam, serving the historic core of the city, its outlying metropolitan areas, and the international airport at Schiphol. It is also one of the main links between the Netherlands and its surrounding countries, providing access to several international trade routes. The core of the station is the historic station building itself, designed by prominent Dutch architect Pierre Cuypers and executed between 1881 and 1889. Although the station is still generally effective as an intermodal transit center, it has been negatively affected over the last fifty years by developments both within the station building and on the site surrounding it.

The current configuration of the site is flawed in several ways which cause its full potential to remain untapped. These flaws basically pertain to three areas: First, the configuration of transport functions, second, the lack of a connection between the historic core of Amsterdam and north Amsterdam across the IJ bay, third, the lack of a waterfront image of the station to complement its city front, and last, the overcrowding of small buildings in front of the station, which prevents the city side plaza from connecting to the city in a satisfactory way.

The configuration of transport functions is dealt with extensively in the section regarding program, but in order to frame the problem it is necessary to describe the basics of the situation here. The station serves an intermodal transit network that is comprised of the following forms of transportation: train, light rail or tram, bus, taxi, bicycle, metro, boat, and pedestrian. The station building and surrounding area have integrated some of these functions more successfully than others; while rail and tram services are located efficiently, bus and taxi services are not, and are difficult to find for the visitor. The other transport options are somewhere between these

extremes, meaning that they are more or less functionally adequate but could be improved in some way. A primary goal of this thesis is to investigate options in which transport functions could be reconfigured in such a way that they are improved functionally as well as addressing the other research goals.

The lack of connectivity between the historic core of Amsterdam and the northern part of the city across the water was caused by locating the station on three artificial islands beyond historic Amsterdam's original waterfront edge. By doing this, Pierre Cuypers effectively created a new city edge or wall and destroyed any direct visual connection between the city core and the water. Given that the waters of the IJ provided Amsterdam with its reason for being, this decision changed the character of the city dramatically and was rather unpopular at the time. Besides eliminating the view of the water itself, it also eliminated the view of the northern part of the city, causing it to essentially be forgotten and languish as a disconnected part. Although functional connectivity exists between the two parts of the city by means of a ferry service and a tunnel, the visual connection, and with it a more conscious awareness of the north area is prevented. Thus, a second key goal of this thesis is to examine ways by which this visual connection could be reestablished, with a view to providing a possibility for reintegrating the northern part of the city in a more meaningful way.

However, another problem that faces this goal is the lack of any real waterfront image of the station; while the south side of the station has a rich historic building and façade, the north side is simply a view of the train sheds and the small exits from the passenger concourse below the track area. When one passes through the station, underneath the tracks, and comes out the other side, they are presented with a busy roadway directly on the water. There is no real pedestrian area or any strong link to the surrounding areas, and so this side of the station is essentially a no-man's land in spite of the fact that the ferry service dock is here, there is a major

residential and office development just to its east, and that this represents the image of Amsterdam on its waterfront and for the northern area of the city.

Therefore, another key goal of this thesis is to investigate a design solution which will provide a stronger image, most likely in the form of a building or group of buildings, which can complement the historic station building at the south, and which can support a pedestrian-oriented area with links to the surrounding developments.

Although the north side has more problems than the station plaza at the south, the plaza also has problems and untapped possibilities. Currently, it is cluttered with buildings serving tourist functions – kiosks, ticketing offices, and such – as well as the tram lines and waiting areas. When a visitor exits the station, they are greeted with a confusing arrangement of transport functions and small buildings, and so the plaza both does not read as a unified public space, nor does it allow one to understand how this space relates to the city around it. Thus, another key aspect of this thesis consists of examining ways in which this plaza could be restructured and reinvigorated as a public space, and to look at ways in which it can integrate more strongly with the urban form around it.

Last is the station building itself; time and pressures of increased usage have forced the historic station building to be altered and expanded in ways that are driven more by economics and utility than by a regard for architectural or spatial quality. The interior layout of the station has become convoluted and bewildering, and the tunnels in the passenger concourse are dark, crowded, and difficult to navigate. Therefore, the last key aspect of this thesis consists of examining the station building as it exists at this moment and to investigate ways in which the building and its spatial experience can be improved.

These aspects all need to be dealt with in such a way that the station building can continue to serve Cuypers' intended purpose of it being a gateway to the city. If it is to serve as such, it is then also important that this gateway is evocative of Amsterdam's city image and all that that entails; the station itself and its spatial experience should prepare the visitor for the experience of the city and should communicate the key elements of the city image. To do this, the above problems must be resolved in such a way that the design proposal can deal with the idea of memory, of culture, and architectonics, while also being a functional solution. The following sections will discuss these ideas and their relevance to this thesis in greater detail, and will establish a rough framework or methodology on which research and design work can be based.

## Chapter 2: Key Concepts

### Theory

#### *On Memory*

This thesis intends to explore Amsterdam's city image *vis a vis* the idea of memory. If the station and surrounding area are to serve as a city gate that evokes the city's *gestalt*, it is necessary for any design solution to address both the layers of memory inherent in the site as well as the city as a whole.

The primary layer of memory in the site is the fact that it is relatively new. Prior to the construction of the station and the island it sits on (hereafter referred to as 'station island'), the site used to be the waterfront edge of Amsterdam's historic core. The waterline stopped at the northern terminus of the Damrak, with waterfront streets extending to the west and east to connect to the rest of the city. This created a direct visual and experiential connection between the water, which is and was Amsterdam's reason for being as a port and trade city.

By constructing the island, this connection was lost, thus severing both the historic core from the waterfront as well as north Amsterdam from south Amsterdam. It is critical for any design proposal for the city to recognize this memory and to respond to it critically; while it is impossible to restore the waterfront to its original edge, it is possible to visually or metaphorically reestablish the original flow of the river Amstel into the IJ bay, and thereby create the idea of connectivity to the water. Doing so would revive the idea of the water's connection and importance to the city, and would allow a memory of the city's original edge to reassert itself.

The primary obstacle to this goal is the station building itself, more specifically its rather long wings. There are various ways of dealing with the station in order to

resolve this conflict, which will be discussed below in the section on preservation. However, it is important to acknowledge that some change to the station building is necessary in order for this memory to reassert itself.

Another layer of memory that can be activated is the memory of the wall. Amsterdam's city walls were removed in the seventeenth century, but fragments of it still remain, allowing the observer to mentally reconstruct its path. This reading allows one to discover the various edges of the city over time, and how the city has grown in response to different pressures from different directions. This then enables a richer, more thorough understanding of the city itself and why it looks and is shaped the way it is, and thus allows for greater comprehension of the city image. If the station is truly to serve as a city gate, it must engage this memory also, acknowledging that the waterfront is as much an edge as the old city walls and that the same pressure for expansion that caused the city to grow beyond its walls has also caused the city to expand beyond its original waterfront.

A key element of city image or city memory is the city's architectonics; most people remember Amsterdam as a city of canals and row houses, and while this is not incorrect in a general sense, it only describes a certain portion of the urban fabric. The waterfront edge of the city has its own texture – mostly large, blocky warehouse buildings – so given the location of the station on the waterfront, these textures must be addressed as well. What is important is that the city's various architectonic traditions define the visual aspects of the city image, and so any design solution for the station island should reference these various traditions so as to form an interface between the 'gate' and the city it gives entry to.

This leads to the last key aspect of memory that should be dealt with: the concept of active memory. This is the idea that certain architectonic design elements of the station island could evoke images of other places within the city. If design proposal

were to adopt an element seen elsewhere in the city – for example, if the main entry to the station were to be altered in such a way that one enters under large arches, as one does at the Rijksmuseum to the south – then when a visitor would reach this other place (in this case, the Rijksmuseum), they would consciously or subconsciously recall the image of the station and understand the tie with this other city element.

If this idea were employed to utilize many distinct images/strategies seen throughout the city, it would create a more active reading of place. At first, if a visitor is proceeding out from the station into the city, they would experience the sort of *déjà vu* or recall experience described above, which both reinforces their memory of the station as well as its relation to the rest of the urban fabric. Then, upon returning to the station, this reading would be further reinforced, and so each time a visitor would make a trip from the station into the city, their reading of the connection between station and center to the rest of the city would allow them to form a richer understanding of their experience.

If this idea is executed correctly, it could enable the visitor to understand intuitively how the city is arranged. The most obvious methodology which could be used to construct this understanding would be to identify major places within the city to reference, and then to develop some concordant design element on the station island which would allow the reading of this connection to surface. The selected aspect could be major public squares, major public buildings, or areas which reinforce the notion of the city growing radially (as it did), or any combination thereof.

If more than one aspect is selected, it also becomes important to establish a hierarchy in the strength of the design elements which evoke the different aspects. If we desire to express both radial growth and a network of public spaces, then it

becomes necessary to identify which of these aspects is more significant or useful to express, and then to express them accordingly with a series of design elements of an appropriate strength.

Clearly, this approach is not an exact science; since we each read any situation or place differently, it is impossible to construct a specific effect. In essence, the idea is simply to provide enough architectural cross-referencing that upon experiencing a place within the city, a visitor will think “I have seen this before, but where?”

Over repeated trips, the visitor will then become more aware of the links between the place they have just experienced, the station, and other places referenced by the station, so that in their mind, a sort of rough experiential network will be created that cross-references different places and their connections (i.e., “I have seen this before at the station...this is how I walked here from the station...I have also seen this before...How does this relate to the place I was before, and to the station”). By establishing this experiential network, it then becomes possible to implicitly suggest a particular reading of the city, whether this is the city as a network of major public spaces, or the city as a radial construct, or some other reading.

Naturally, each of these readings has its own implications; for example, if we choose to attempt to activate memories of public spaces, there must be a selection of which public spaces to evoke and why. If the visitor creates a mental network of public spaces, the spaces within that network will obviously strike them as the most important spaces within the city, and so there must be a very deliberate choice in which spaces to select.

It is also important to note that within this idea, the station transcends its role as a transportation hub to become associated with the reading of “gate” or “entry”; when forming a mental network, the visitor would create their spatial reading of the

city relative to this entry. What this means is that rather than saying that all experiences should relate back to the station (which seems to aggrandize the station and this thesis), the idea is more about creating the idea of a particular circulation or promenade throughout the city relative to the gate or point of entry.

Again, this thesis recognizes that this idea is not going to work literally as described. It may or may not work for any particular person; however, the subconscious subtext of establishing these memory links allows the potential for a richer and more thorough understanding of the city than “now I am here, now I am there” for the average observer. If we can describe Amsterdam as a city based on trade and exploration, then we can say that in these activities it is necessary to know where one is relative to other networks (trade routes, geography, etc.) and that creating this implicit reading of the city is reinforcing a key aspect of the view of life as held by the city’s inhabitants.

It is critical for any design solution to engage these ideas about memory in order for the station and its surrounding area to be able to serve the goal of being a true ‘city entry’ and to evoke the city’s image for the visitor. By engaging these ideas, it becomes possible to elevate the station from being a mere building to being a key element of a richer promenade through the city.

## ***Preservation?***

This thesis considers all buildings to be malleable creations. Just as the design process is never truly complete, neither is a building; many if not most buildings are altered after their creation in some way, whether it is the rearrangement of existing conditions or the addition of exterior or interior space. In this way, most buildings are palimpsests, and by extension, so are nearly all urban fabrics. The word palimpsest is thus so universally applicable within architectural and urban contexts that the word itself becomes nearly superfluous – any good architect should understand that they are operating within various layers of history, and should respond to this idea *in some way* in their design proposals. The specific ways are of course limitless and not definable, but it should be apparent that a basic distinction between a good and a bad architect is that one responds to embedded events and histories and the other does not.

In any case, the idea of palimpsest has certainly been continuously employed in Amsterdam. Perhaps one of the most obvious examples are the gates that remain from the first city wall – St. Antoniespoort, Regulierspoort, Montelbaanstoren, Schreijerstoren. All four of these gates have been altered or added to in order to accommodate functions ranging from office space to mint. Some of these alterations are relatively minor, such as the new roof and addition to the Schreijerstoren, while some are major, such as the roofing over of the courtyard of the St. Antoniespoort to allow it to serve as *waag*, or weigh house. A more modern example would be the re-use of and additions to the shipping warehouses on the Prins Hendrikkade, just a few hundred feet east of Centraal Station. New buildings have been built next to, into, and over original buildings and have densified the area, while strengthening the street edge and providing a new image from the waterside.

There are many more such examples within the city, but perhaps these are enough to establish that Amsterdam has a tradition of reusing historic buildings in various

ways, and that architects have never been shy about altering these buildings in order to allow them to better serve their new purposes. Cuypers, architect of Centraal Station, was himself not restrained in this sense either; he notoriously 'restored' old churches and cathedrals by tearing down elements that he considered incongruous, and replacing them with his own designs. A notable example is the cathedral of St. Servaas in Maastricht, where Cuypers replaced several towers and the entire interior (which has since been restored).

These examples show that within the cultural context of Amsterdam and the Netherlands in general, there is a sense that no buildings are sacred, and that they may be modified, reduced, enlarged, or drastically repurposed. This precedent allows and perhaps encourages the notion that the station building itself should not be regarded as an immutable historic object, but rather as a malleable condition which may be operated upon and remolded in various ways.

The various possible alterations to the station should be explored and evaluated according to several criteria: First, and most important, is its degree of invasiveness. The station is a key part of the city image, and therefore some iconic aspect of it has to survive in order for it to retain some of its function within the city image. This is a key aspect of the examples I listed before, all of which maintain the core image and aspect of the buildings before their alteration. A consequence of this idea is that the option of completely removing the station cannot be exercised without having a significant effect on the city image – one that dispenses with too many layers and memories of history to be appropriate for the goals of this thesis.

Thus, we must evaluate how much of the station it is necessary to keep in order for the city image not to be affected too drastically. This is not extremely difficult: The most iconic and key aspect of the station is its central pavilion, with gate and towers. This is the portion of the station which allows it to serve visually and metaphorically

as a 'city gate,' and is the most recognizable aspect of the building. The next key aspect is the side pavilions, which mark the ends of the building and are architecturally distinct from the rest of the wings. The connecting wings themselves are the least important parts to keep, because while some of their interiors contain some significant spaces, externally they simply serve the visual function of 'wall.'

This leads to the second criterion by which alterations should be evaluated: their potential to allow a connection to the northern waterside of the station. The 'walls' created by the connecting wings are the primary obstacle to this goal, and so their removal, replacement, or alteration is quite desirable. Each of these is a viable option; by simply removing them, one achieves a similar effect to leaving the city gates in place after the removal of the city wall, where the three pavilions become freestanding 'gates' and provide a visual memory of the 'wall' formed by the station. The three pavilions may then be operated on in any way such as to reconfigure the station for contemporary needs and services. The 'walls' could also be altered in such a way where only parts of the wings would be removed, and so the 'wall' could be pierced within completely destroying it or having to replace it. Lastly, the 'walls' could also be replaced by another liner of any texture, material, or opacity that would be responsive to the city image and the city's architectural traditions. This idea is explored more thoroughly in the section on tectonics.

Each of these three operations has its relative merits, demerits, and implications. Whether one wishes to destroy the 'wall,' pierce it, or replace it makes a statement about the role of the station building and its function within the city. However, given the fact that the station has many functions within the city and that the site has had changing characteristics over time, any or all of the options may be appropriate, and any design proposal will probably be a mix of approaches. When dealing with a city image as culturally, architecturally, and socially diverse as Amsterdam, it would be a mistake to simply choose one approach; it is this type of action that generated the

station building and its placement in the city in the first place, and if we are to deal with the problems caused by this prior mistake, we cannot take the same attitude without merely magnifying the error.

The final criterion for evaluating the scope of alteration for the station building would be how well various options respond to opportunities for reconfiguring the circulation of transport and pedestrians on the site. Since this is a major component of this thesis, this criterion is key to generating a design proposal that is able to be inventive about the ways in which Amsterdam Centraal can serve as an intermodal transit center. Interestingly, many options can be generated merely by removing the service wings of the station and providing through connections to the waterside underneath the tracks. This allows the entire station building to escape unscathed, but limits the circulation and interaction between the existing station and the new transit areas. Due to the shape of the station, pedestrians would be required to circulate from the sides to the front before entering the station, which would leave the transit areas isolated. Since this thesis intends to increase the links and interactions between the various modes of transport, this seems to suggest a somewhat more invasive strategy.

These three criteria offer a methodology for generating and evaluating design proposals. They also outline the major goals of the thesis: to maintain the key aspects of the station for the city image while simultaneously reinterpreting the station and its surrounding site, to establish a stronger condition with the northern waterside and north Amsterdam and to restore a memory of the original course of the river, and to reconfigure transport functions on the site in order to allow them to function more efficiently and be better integrated. All design proposals will thus be guided by these core tenets.

## Culture

### *Architectonic Traditions*



Figure 2 - Beurs van Berlage



Figure 3 - Station Amsterdam Sloterdijk



**Figure 4 - Oude Kerk / Old Church**



**Figure 5 - Typical Rowhouses**



**Figure 6 - Old Waterfront Warehouse / Brick Detailing**



**Figure 7 - Lloyd Hotel / Brick Detailing**



**Figure 8 - New Waterfront Housing (The Whale)**



**Figure 9 - ARCAM Building**



**Figure 10 - Centraal Station Detail**



**Figure 11 - Corner House Along Canal**

## Chapter 3: Site Analysis

### Diagrams

#### *The Growth of Amsterdam*



Figure 12 - Original River Course and Waterfront



Figure 13 - Addition of First Canal



**Figure 14 - Addition of Second Canal; Two Canals Mark Oldest Core of City**



**Figure 15 - Addition of Service Canals at Dock Areas**



**Figure 16 - Planned Growth Via Radial Canal System**



**Figure 17 - Completed Canal System with Defensive Outer Ring**

## The Amstel River



Figure 18 - Axial Connection Between Central Station and Dam Square



Figure 19 - Overlay of Original Course of Amstel River

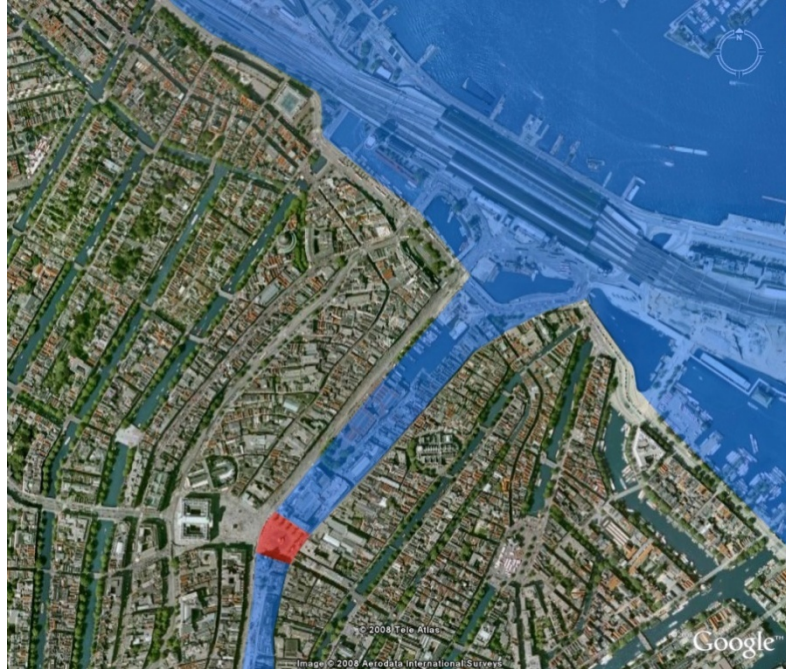

Figure 20 - Original Flow of Amstel and Location of Dam



Figure 21 - Visible Waterfront from City Side Relative to Centraal Station

## Transport Functions



Figure 22 - Train



Figure 23 - Train and Light Rail



**Figure 24 - Train, Light Rail, and Bus**

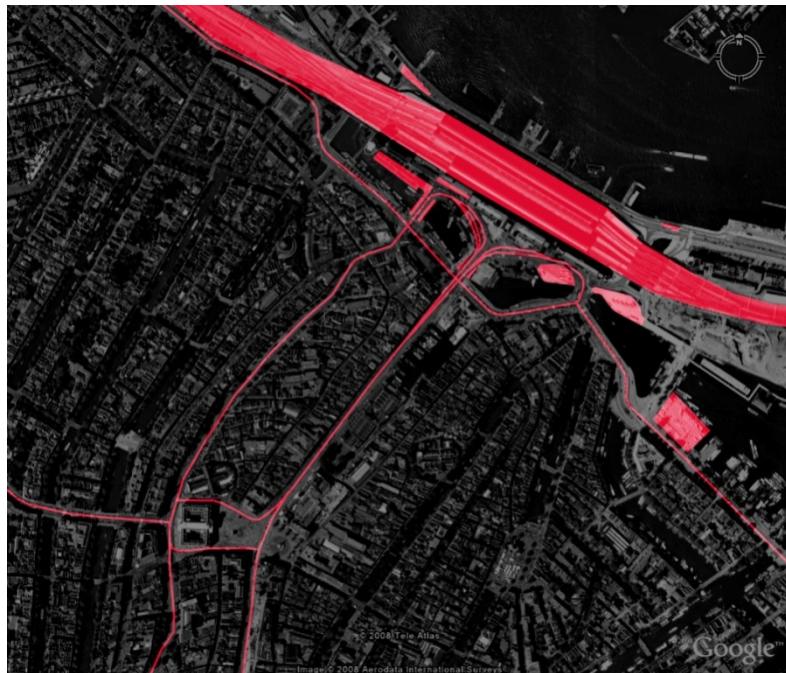

**Figure 25 - Train, Light Rail, Bus, and Bicycle Storage**



Figure 26 - Train, Light Rail, Bus, Bicycle Storage, and Boat Areas

### ***Connections Between Historic Amsterdam and Amsterdam North***



Figure 27 - Historic Core of Amsterdam and North Amsterdam

## Iconic Buildings and Places



Figure 28 - Key Places in Historic Central Amsterdam



Figure 29 - Transport Links to Key Places

## **Programmatic Needs**

Since Amsterdam Centraal Station is an intermodal transportation center which serves as a city entry, the program of the station and site are quite complex. Although the station is able to support its transport functions relatively effectively, there are some issues with their current configuration which must be addressed if the site is to be improved. While trains and light rail (trams) are effectively and efficiently routed through the area, buses, taxis, bicycle traffic, metro, and boat traffic can all be improved.

The bus situation is the most urgent, as the large volume of buses currently has no central hub at the station and has instead been distributed over five separate depots surrounding the station area. This arrangement is confusing for visitors and inconvenient for commuters and inhabitants. The Stationseiland project is primarily aimed at addressing this issue, and resolves it by means of building an additional shed onto the rear of the station, which serves as a central bus terminal.

While this fulfills the programmatic requirement, it may not represent the optimal solution. By adding yet another shed onto the station, the distance between the city and water sides is increased, leading to even less connectivity between the north and south of the station despite the projected addition of a pedestrian area near the water. It also fails to provide a waterside image of the station that truly addresses the character of the surrounding waterfront area, opting instead merely for a shed with "Amsterdam" written on it.

Although the scheme does have positive qualities, namely the creation of a pedestrian boardwalk along the water, the consolidation of bus routes into one area, and the reinforcing of the image of the train sheds themselves, it is the opinion of this thesis that a better solution can be suggested which maintains the positives

of the Stationseiland scheme while adding to the station in a more sustainable manner.

Taxi service is another transport functions that needs to be addressed in a more proactive manner than has currently been done. Taxis and service vehicles can currently enter the station plaza on both the west and east sides, but the only drop-off and waiting area is on the west side, where it is quite small, interferes to some extent with both the tram waiting areas and the pedestrian traffic moving through them, and is not visible enough for the passenger.

Taxi service should be given a larger priority and consolidated into the station itself in some manner that can link more directly to the passenger concourse as well as whatever central hub is established for the buses. This will allow visitors to more easily find both modes of transportation, and also makes the delivery and pick-up of passengers significantly easier for taxi drivers. Since both buses and taxis use the tram lanes in Amsterdam, it should be possible to reconfigure the tram entries at the east and west areas of the plaza in such a way as to provide greater connectivity to the waterside, probably by means of establishing a roadway that goes underneath the rail tracks.

The reconfiguration of the other transport modes is perhaps less critical to the success of this thesis, but it is important that they be addressed anyway. Of the three (bicycle, metro, and boat), the bicycle situation is probably the one that needs the most attention; despite the addition of a bicycle parking garage on the west side of the station, there is still an overflow of bicycle traffic, causing commuters to chain their bicycles to the railings of the three connecting bridges to the station island. This situation is visually unappealing, makes it difficult for commuters to find their bicycles, and leaves the bicycles prone to theft, which is a common occurrence.

Since the bicycle garage seems to be fairly effective in and of itself, and given the large amount of bicycles that it is able to accommodate, this thesis proposes to keep the garage, but to add large bicycle storage areas within the station building to address commuter needs. These areas would be monitored by security, reducing the likelihood of theft and allowing commuters to feel more secure. These areas would need to have direct access to the outside, would need to be large enough to accommodate at least all the overflow bicycles currently being stored on the bridges, and would need to be connected to the passenger concourse in such a way that passengers can easily move between their bicycles and another mode of transport (most likely train or tram).

The question of metro access should be fairly simple to address. The main problem with the entrances to the existing station is aesthetical; the twin stainless steel boxes that take one down to the station seem rudely dropped into place on the plaza and do not reflect any significant architectonic tradition. Essentially, they simply need to be relocated slightly to provide them with a more logical place within the place, and the physical entries need to be replaced with a more appropriate form.

There will need to be two new entries to the new station of the north-south metro line that is being constructed underneath the island; these should be integrated into the passenger concourse of the station and should provide a relatively direct link between the train platforms and the metro below. Since the design and precise placement of the station are part and parcel of the Stationseiland project, this thesis will regard them as malleable, so that the metro concourse can be redesigned/relocated to integrate more successfully with the metro entrances once an appropriate place for them has been determined.

Last is the issue of boat traffic. There are currently two major aspects to this on the site: on the south side, there are the docks and support buildings for the tour boats that travel through the historic city, while on the north side is a ferry terminal that provides ferry services between north Amsterdam and the station. While there is nothing particularly problematic about their location or the way that they interface with the station, both areas could be improved.

The major issue with the southern boat traffic (tour boats) is that the support buildings simply do not fit into the character of the site in terms of scale or architectonics, and that having these small buildings sitting on the edge of the plaza clutters the space and prevents visitors from having a clear visual connection between the city and the plaza. The buildings, while constructed in the twentieth century, have been designed in a sort of kitschy “traditional Dutch house” style which is clearly intended to speak to tourists visiting the city. However, this type of building simply does not exist along the historic waterfront of Amsterdam, and so they represent an anomaly as well as an anachronism.

The uses contained in these buildings – ticketing offices, restaurants, and tourist information kiosks – are pertinent to the site and should be maintained. However, their built form should be reconsidered so that they are not as visually obtrusive as they currently are. Among many possible options is the idea of sinking them into the plaza level, so that they find their primary expression in the retaining wall next to the dock, rather than sitting as disparate objects at the edge of a public space. Whatever solution is ultimately employed should address these issues, as well as arrange the spaces in such a way that they can relate to the metro entrances on the plaza, which are adjacent to the existing set of buildings.

The northern boat traffic (ferry service) is perhaps the easiest issue to address. Its main problem currently is that it simply is not integrated well with any of the

northern exits of the station or any of the surrounding areas, and so the primary goal here should simply be to strengthen those connections and to make the ferry pier and service buildings more directly apparent. There should be a direct and visible connection between the passenger concourse of the station and the ferry areas. This connection should serve to reinforce the connectivity between the city and water sides of the station; it could perhaps serve as the northern anchor for pedestrian circulation through the site.

From this discussion, it becomes apparent that there are essentially two kinds of problems here; First, are the transport functions which need to be reconfigured due to their current inefficiency, while second are the transport functions who should be reconfigured in order to allow the station and plaza areas to be designed holistically. In other words, while the current bus and taxi services are not adequate, the other modes of transportation simply need to be integrated more strongly into the station and plaza so that they read as a whole instead of a collection of unrelated parts.

So far, this discussion has addressed only the transport functions themselves. However, there naturally are many support spaces that accompany these functions, including (but not limited to) ticketing offices, mail services, banking services, office space, retail space, item storage, and other service functions. This thesis perceives the existing service functions to be appropriate, but believes that they could be arranged differently within the station building in order to make them more easily accessible and visible to the traveler.

While automated ticketing services are easily found, the actual ticketing desks are somewhat hidden away in the service building on the west side of the station, and should be reintegrated into the main station area itself. Likewise, banking and ATM services are scattered around the passenger concourse in isolated and sometimes difficult to find areas, and should also be relocated to be more easily accessible.

The current interior arrangement of the building reflects a need for more space, specifically for office and service functions. The original floor layout of the building has been altered by insertion of interstitial floors and partition walls, which destroy the intended experience of the building and cause it to feel overcrowded. The addition of a new set of buildings and spaces could address these issues in such a way that the space needs can be accommodated while the old building can be restored to a more appropriate internal arrangement.

# Chapter 4: Design Considerations

## Preliminary Explorations

### Program and Parti

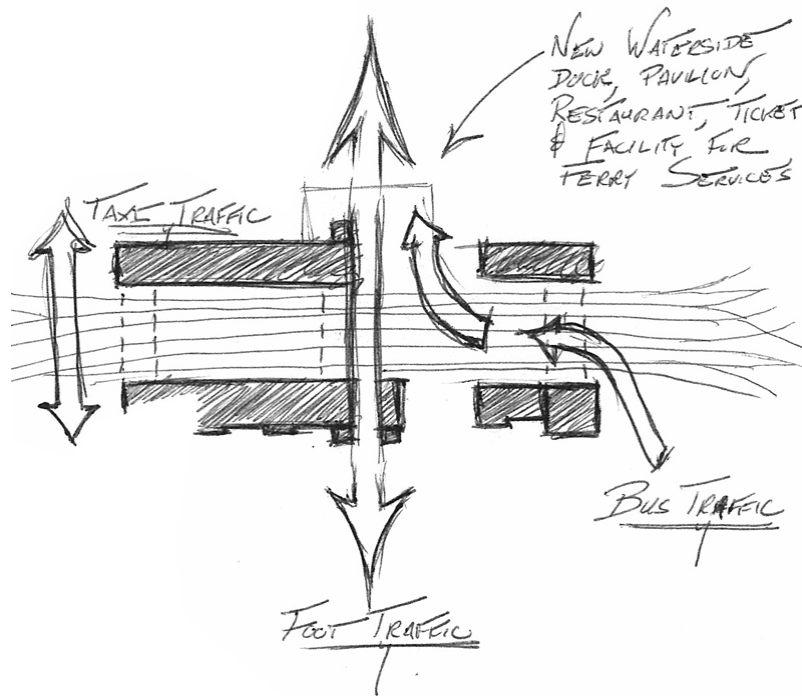

Figure 30 - Traffic Parti Diagram

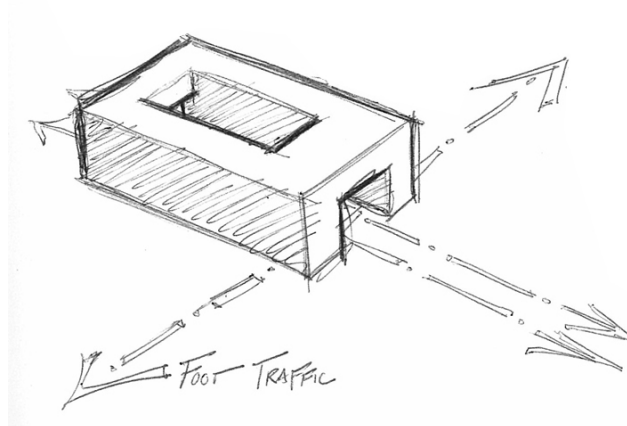
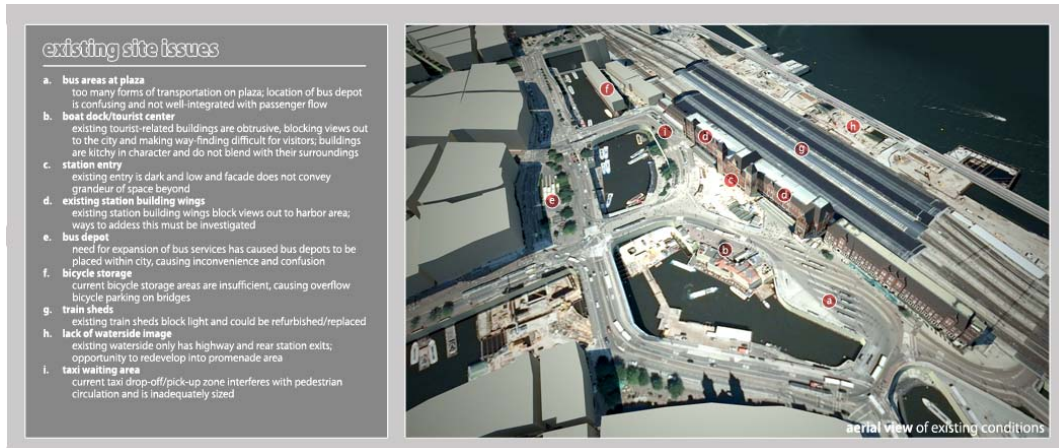

Figure 31 - Foot Traffic Diagram



**Figure 32 - Programmatic Issues**



**Figure 33 - Site Scheme**

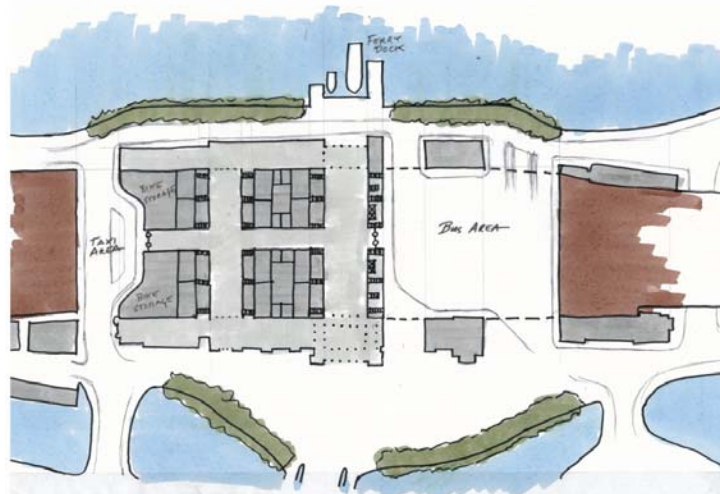

**Figure 34 - Scheme 1 Plan**

## ***Visual Connectivity with the IJ***

Due to the length and size of the building, it is extremely difficult to achieve visual connectivity with the water of the IJ (fig. 35).



**Figure 35 - View of Centraal Station**

Early studies had looked at removing parts of the station building in order to achieve this (fig. 38). However, even with the removal of parts of the station, the expanse of ground covered over by the tracks still makes a true visual connection all but impossible. Figures 39 and 40 show the light levels within the central passage underneath the track area, and also demonstrate how difficult it is to see anything at the end of this length of space. Sky lighting strategies, explored in figures 41 and 42, manage to address this issue somewhat by increasing the level of daylight and thus also visibility. However, with the current height of the ceiling as low as it is at ten feet, and the length of the corridor being about 320 feet, it would still be difficult to achieve a meaningful view once the passage is filled with the mass of commuters that use the station on a daily basis.

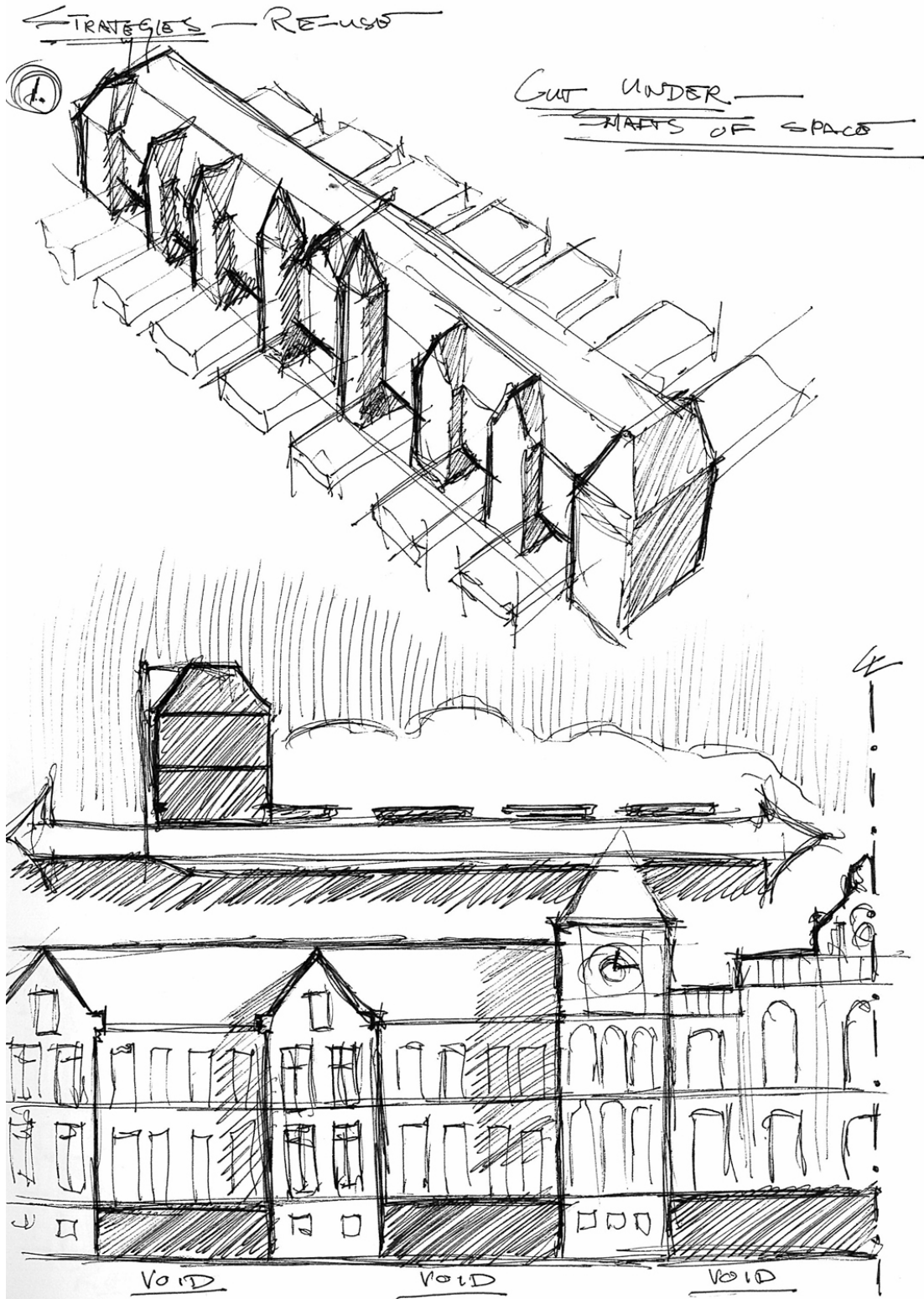

Figure 36 - Strategy 1: Cut Under Station

STRATEGIES - REUSE

(2)

GROW OVER  
CONNECTING RIBBONS

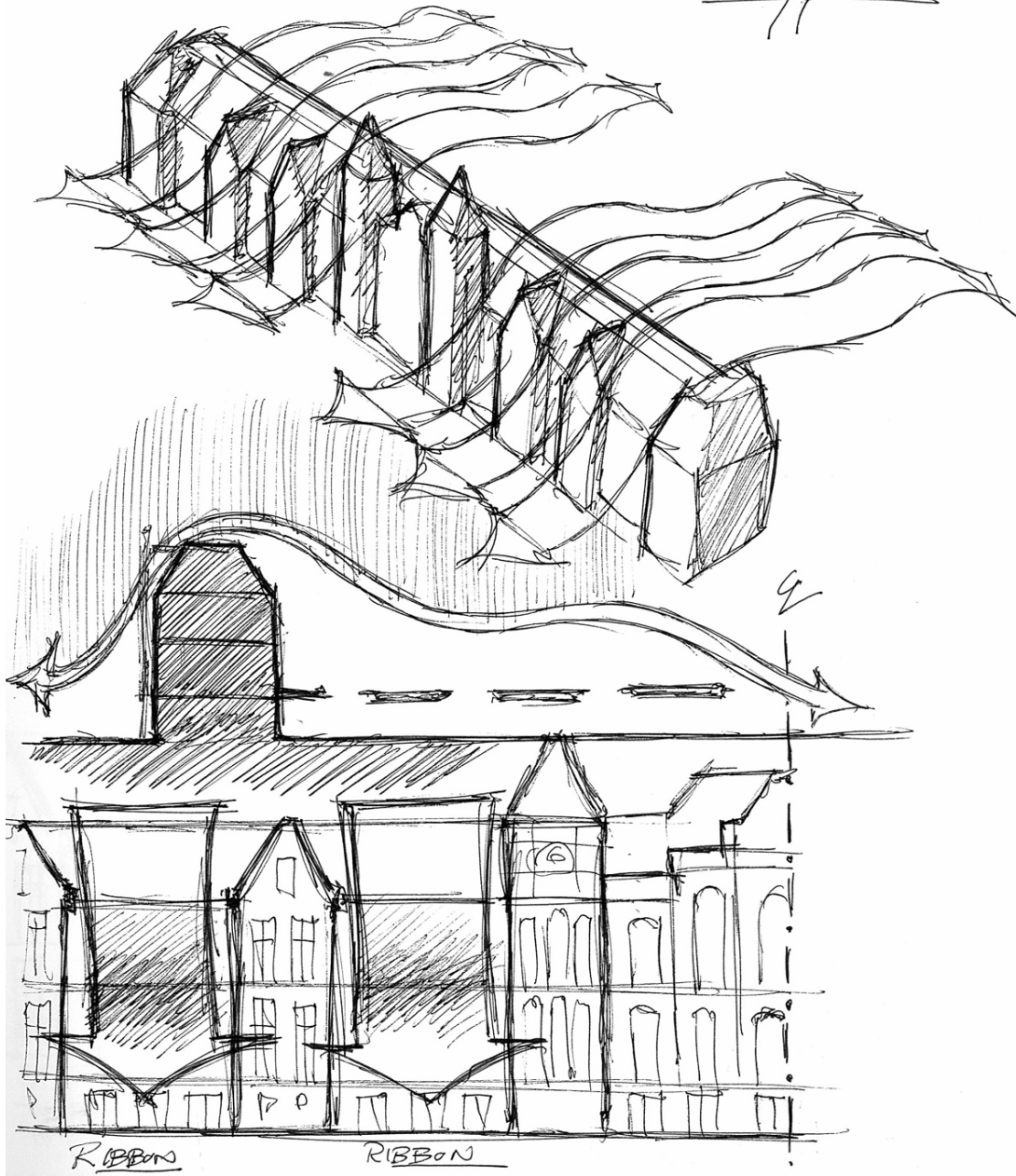

Figure 37 - Strategy 2: Go Over Station

STRATEGIES — REUSE

(2)

PAVILIONS /  
MACRO TUNNELS

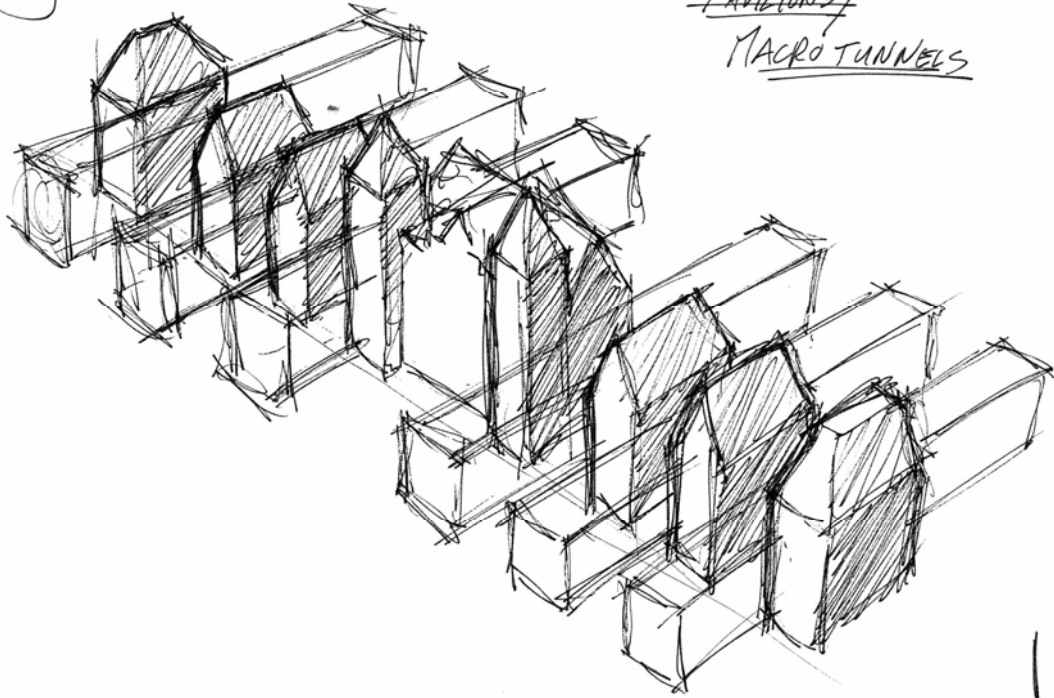

Figure 38 - Strategy 3: Cut Through Station



**Figure 39 - View of Entry Hall with Existing Central Passage**



**Figure 40 - View of Existing Central Passage**



**Figure 41 - View of Entry Hall with Sky lit Central Passage**



**Figure 42 - View of Sky lit Central Passage**

This means that the option of cutting underneath the station, shown in figure 36, is therefore unlikely to succeed. This means that perhaps it is wise to explore a more abstract strategy that tries to a metaphorical connection to the water rather than a literal view. Figures 43-45 show ideas for implementing linear water features along the path from the Dam to the station along the original course of the Amstel River. This could potentially strengthen the memory of the old connection to the IJ. Figure 37 shows the idea of having visual features 'growing' over the station as a possible visual strategy for implying the continuity of the city behind the building. In lieu of a true visual connection, these two strategies could potentially imply the presence of the IJ strongly enough to restore some sense of connection.

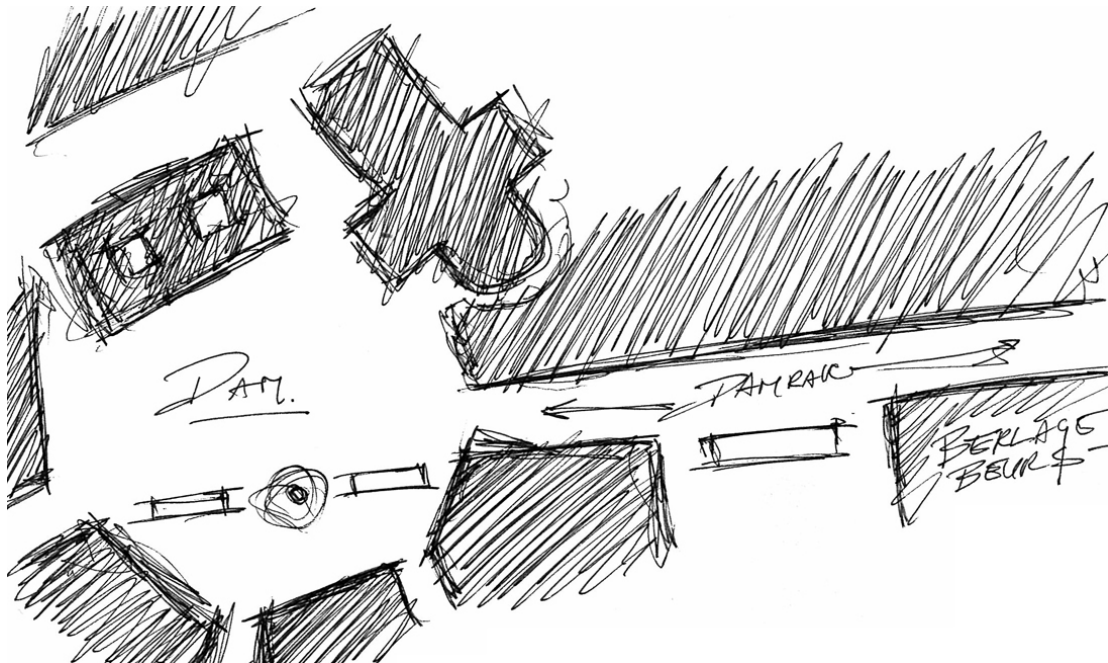

Figure 43 - Diagram of Water Procession from Dam to Station

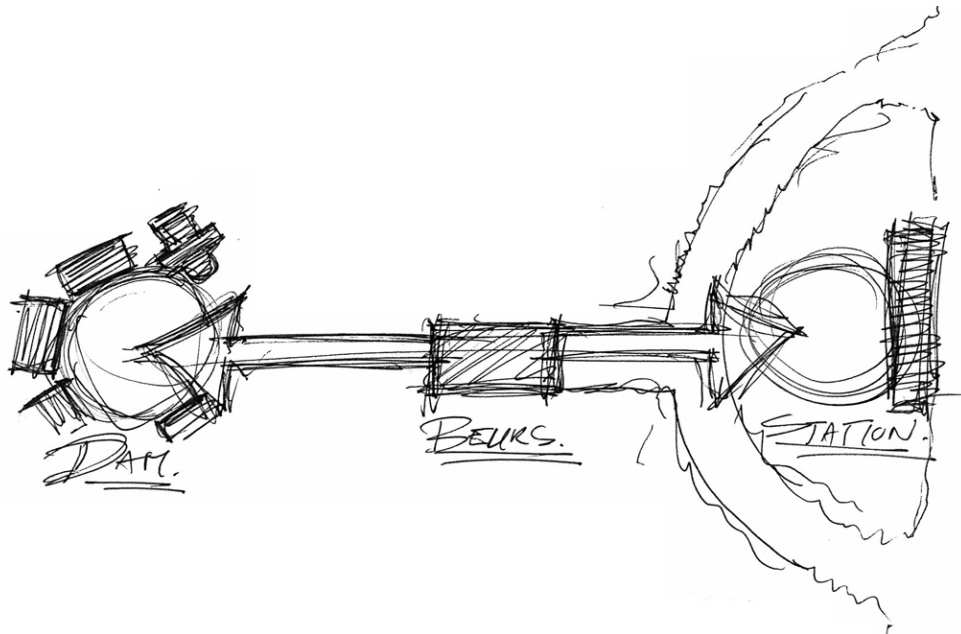

Figure 44 - Diagram of Water Proceesion from Dam to Station

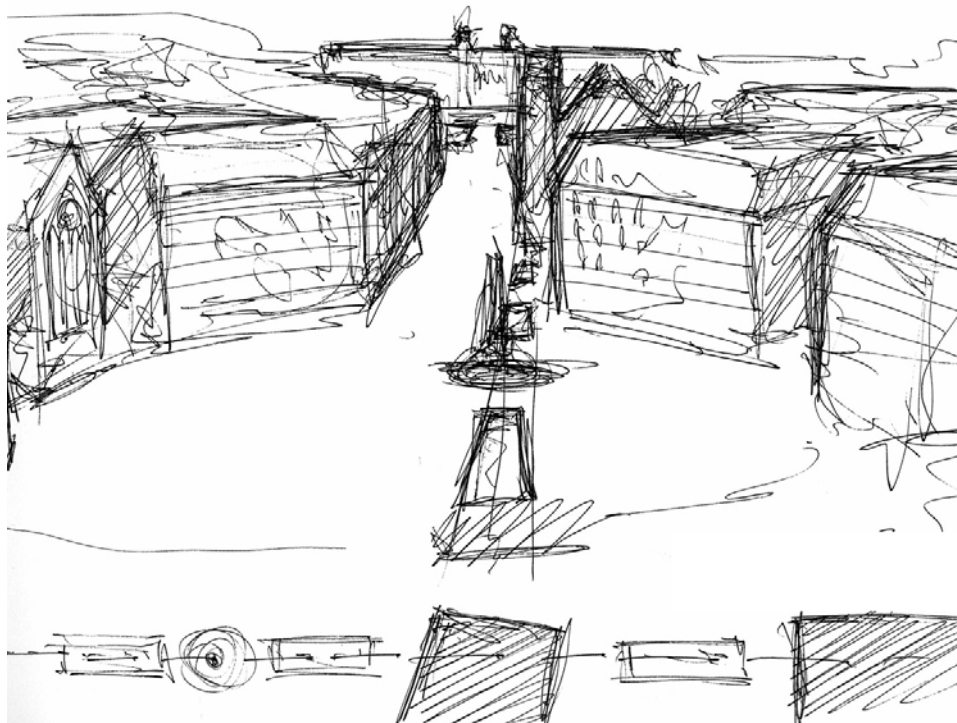

Figure 45 - Perspective of Water Proceesion

### ***Waterfront Image of the Station***

Centraal Station does not truly have a meaningful image on its northern waterfront side. This area of the station essentially consists of nothing more than the end of the last train shed and the rear doors of the station opening onto a busy road (fig. 46).



**Figure 46 - Centraal Station Waterfront Side**

This is one of the main problems with the station. If Centraal Station is to have a meaningful connection with its adjacent residential areas, the waterfront at the IJ, and Amsterdam North, it needs to have a presence on the water side which is equally as effective and meaningful as its city side. Benthem Crouwel's scheme for the Stationseiland project acknowledges this idea somewhat, by attempting to provide a pedestrian promenade as well as some amount of imageability in the form of the city name being displayed on the newest shed. While the pedestrian area seems generally well-integrated, the text on the sheds seems like an afterthought, and is probably only really effective when seen from the air.

This is where the notion of placing another building on the northern side (rather than another shed) becomes very useful. Amsterdam's water edge is generally defined by buildings, which also tend to be of similar tectonic character (fig. 48-50); this begins to suggest some ideas for how to create a building which can tectonically respond to its context in such a way as to create a water side image of the station which is more in tune with the surrounding areas of the city.

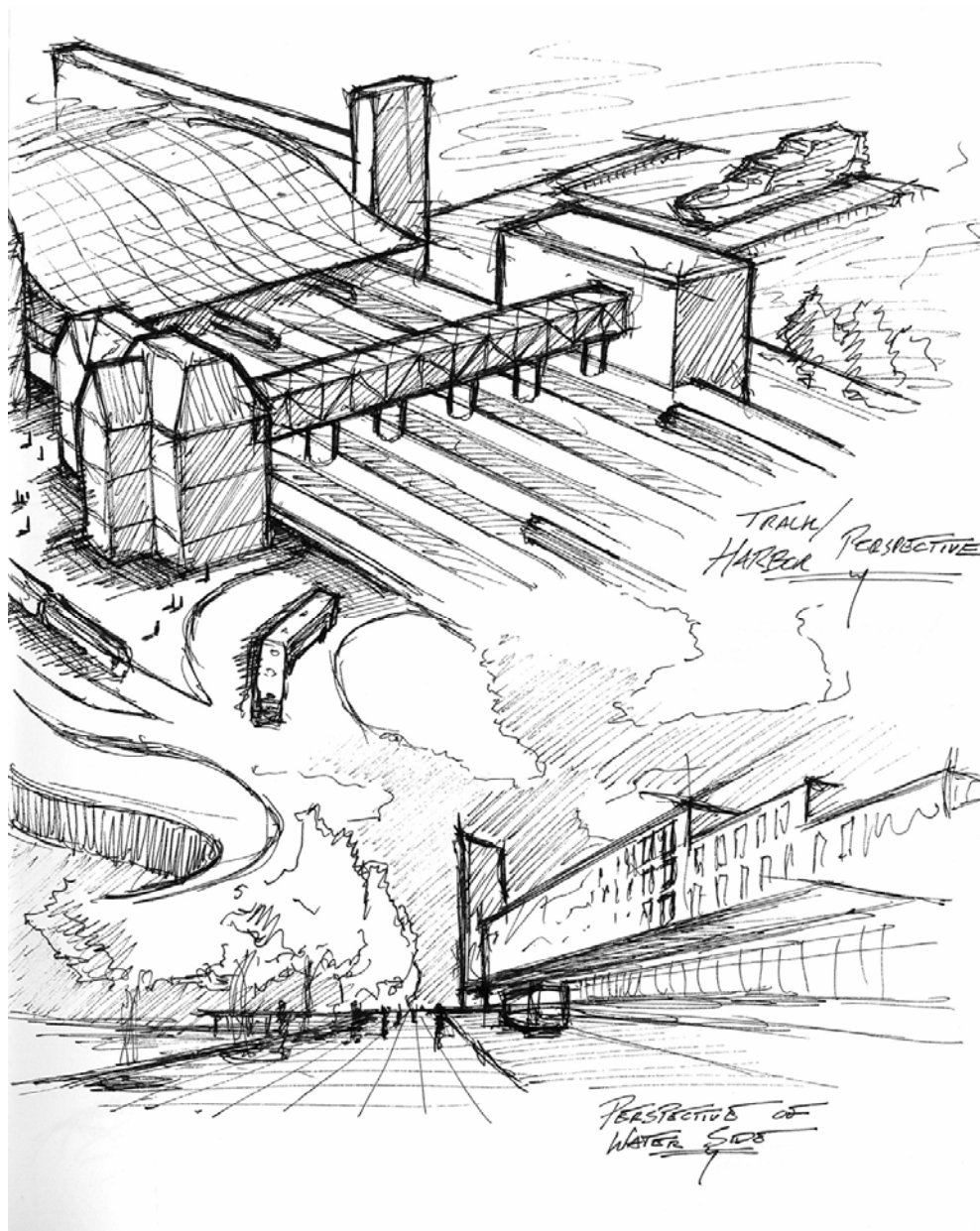

Figure 47 - Schematic Perspective Views with Northern Building



**Figure 48 - Tectonic Reference: Warehouse**



**Figure 49 - Tectonic Reference: Warehouse**



**Figure 50 - Tectonic Reference: Brick Detailing**



**Figure 51 - Tectonic Reference: Muziekgebouw**

## Station Plaza

Activating the potential of the plaza side of the station is paramount to any successful reimagining of the station and its role in the city. It is somewhat difficult to begin exploring this until a clearer idea emerges of how many activities will be removed from the plaza and into the station. However, an idea that is being explored is to sink the boat and tourist buildings below the plaza so that the view from the station into the city can be improved (fig. 52). Another issue which must be addressed is the need to make wayfinding easier for pedestrians; including a more obvious entry to distinct areas, such as the bus area, could aid in this regard (fig. 53 shows an extremely diagrammatic concept for this).

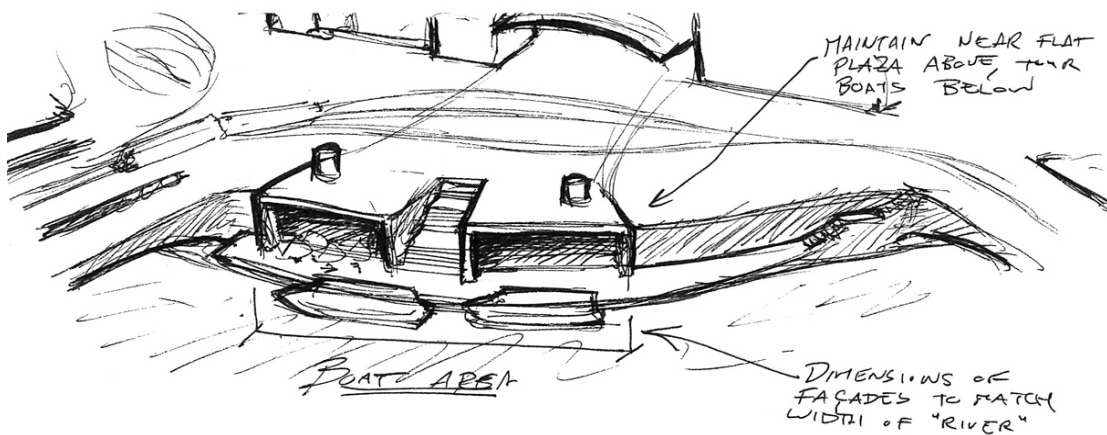

Figure 52 - Schematic Drawing of Boat Area

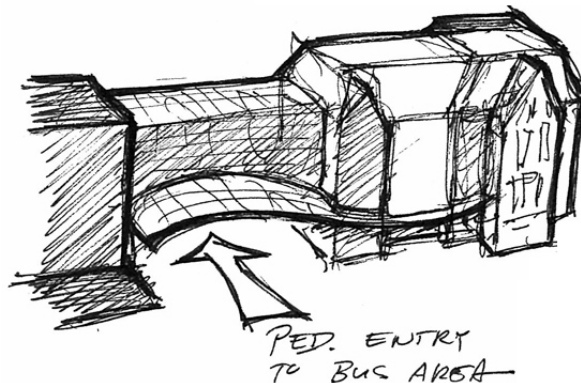

Figure 53 - Schematic Drawing of Pedestrian Entry to Bus Area

## The Station Building

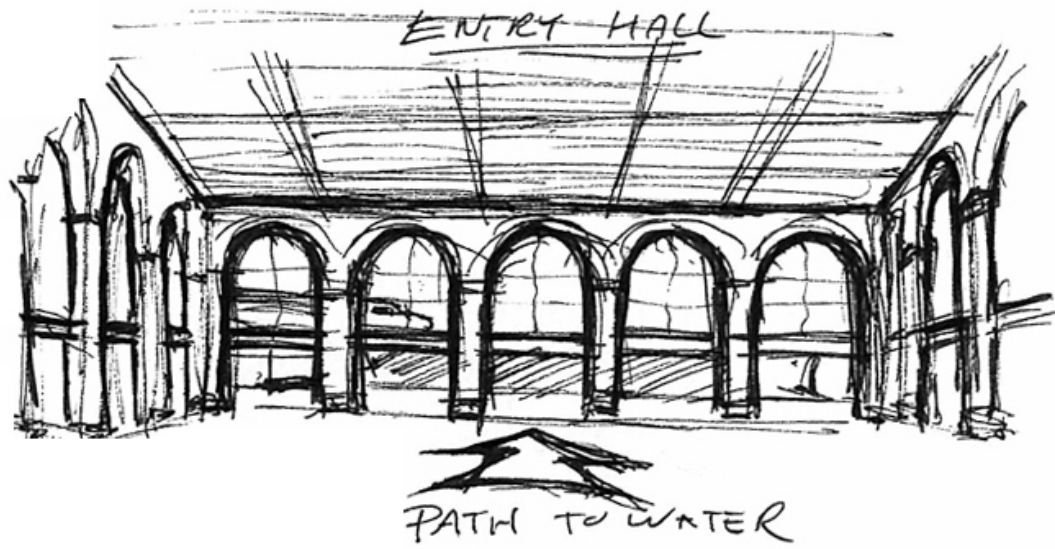

Figure 54 - Entry Hall Perspective

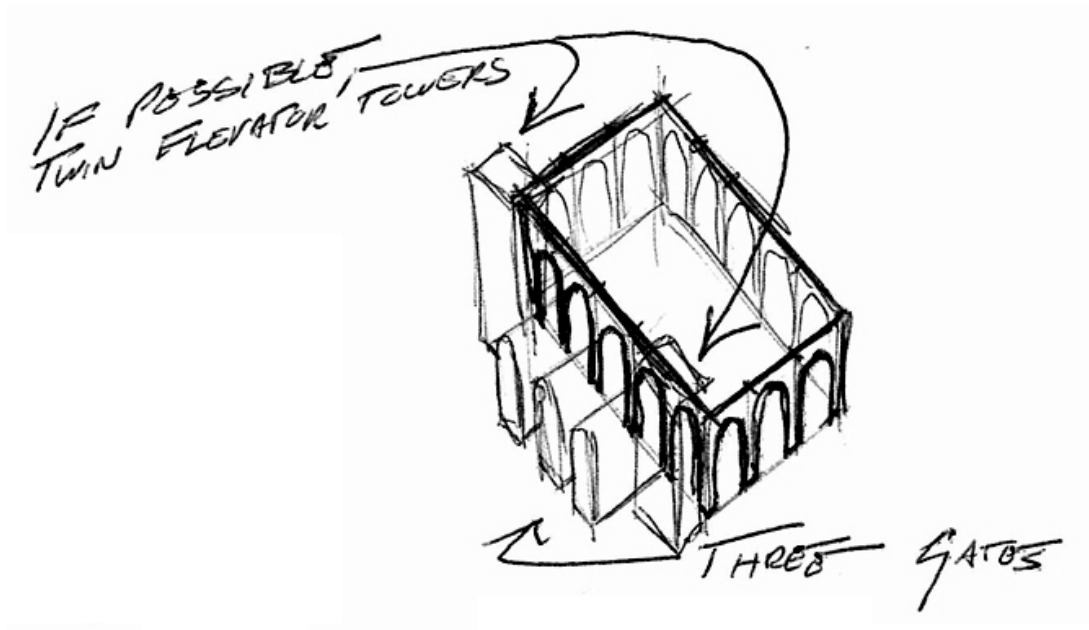

Figure 55 - Entry Hall Diagram

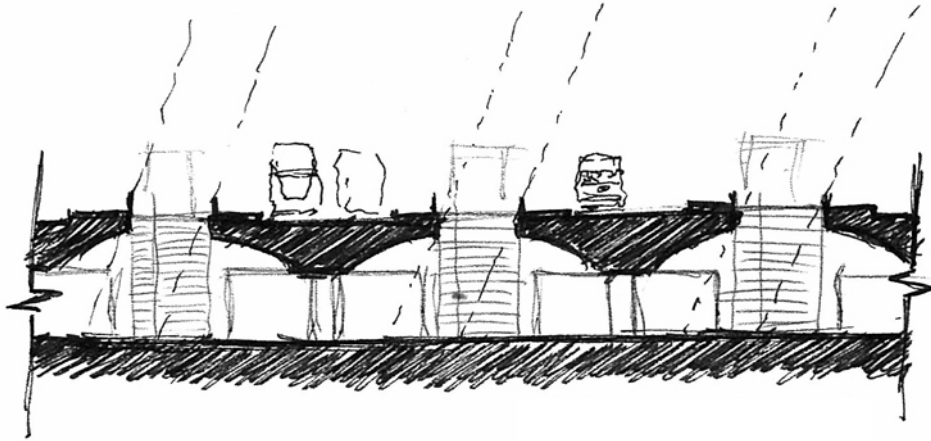

Figure 56 - Schematic Central Passage: Longitudinal Section

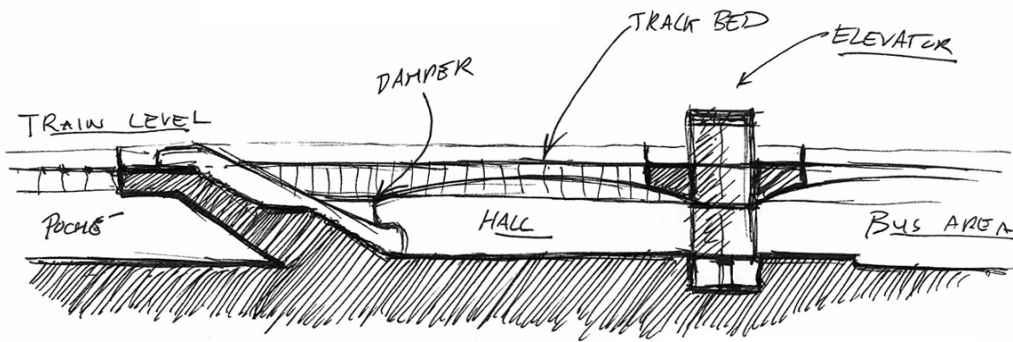

Figure 57 - Schematic Central Passage: Transverse Section

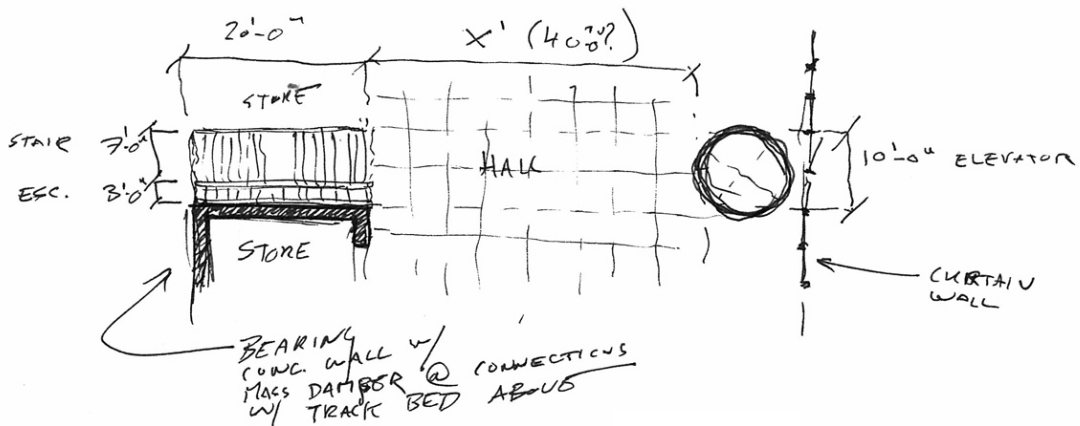

Figure 58 - Schematic Central Passage: Plan

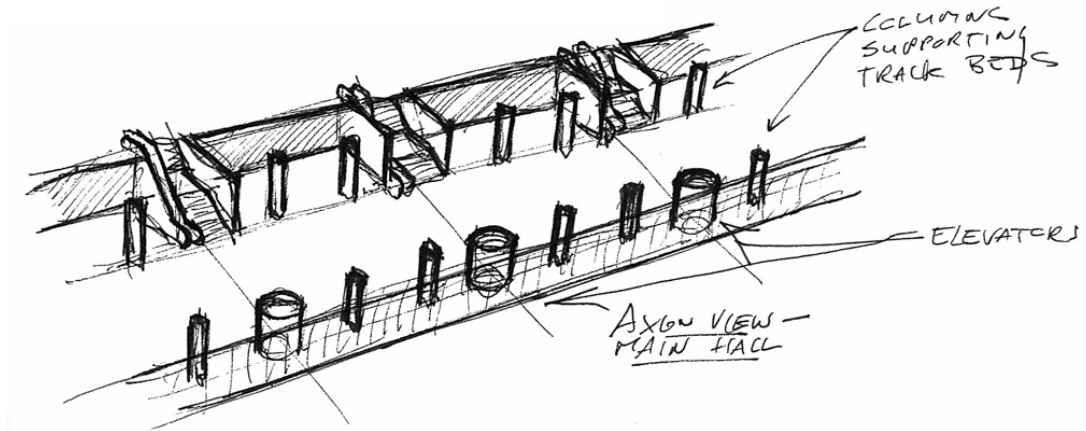

Figure 59 - Schematic Central Passage: Isometric View

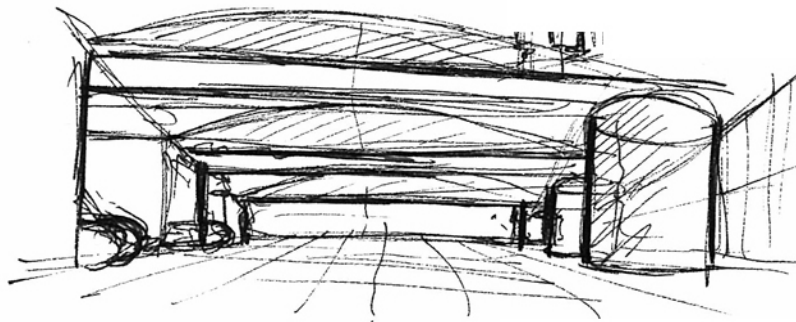

Figure 60 - Schematic Central Passage: Perspective Down Hall

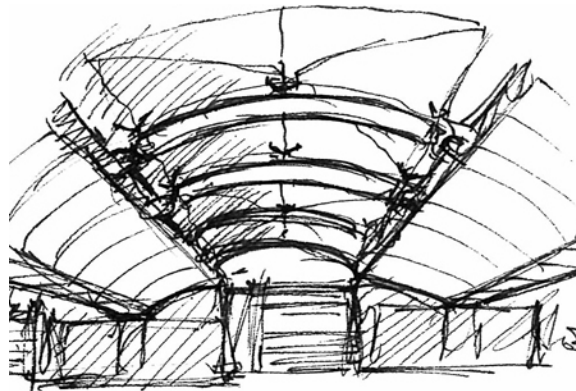

Figure 61 - Schematic Central Passage: View of Track 'Vaults'

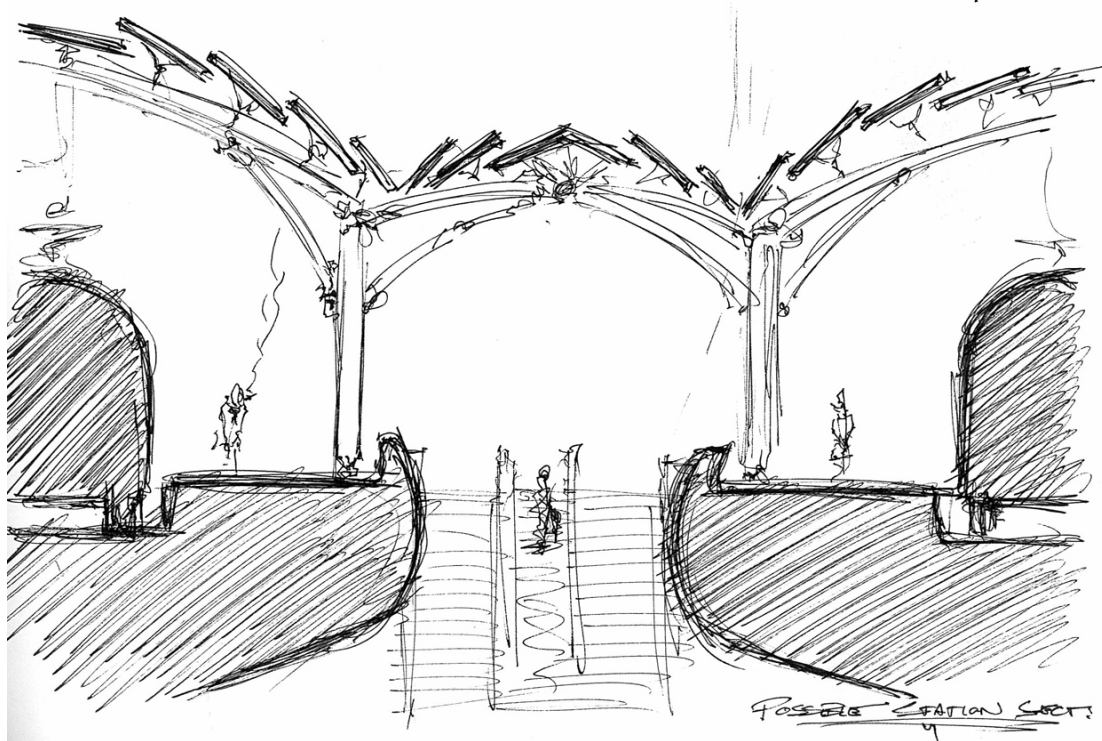
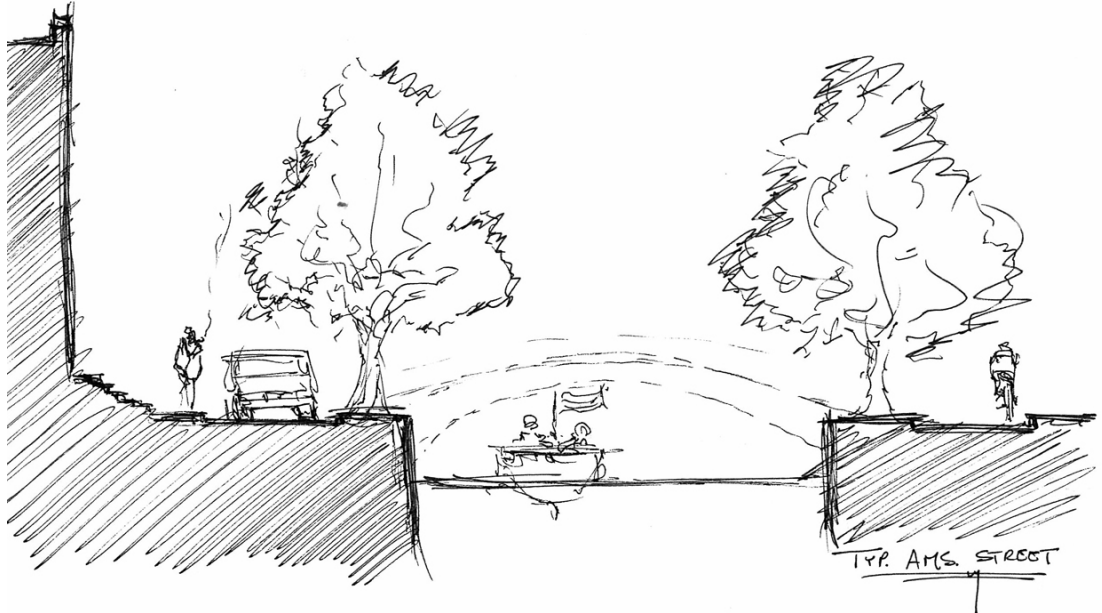

Figure 62 - Comparing a Typical Amsterdam Street Section to a Possible Station Section

## Chapter 5: Design Process

### Restoring the Connection between the City and the Water

#### *Developing the Connection through the Station*

The existing station functions as a closed gate at the end of the city, giving no hint of the water lying beyond (Fig. 63). Ideally, it should be made to function as an open gate, one which forms a point of transition between the city center and the waterfront (Fig. 64). As established in earlier sections, a literal visual connection between the city and the water is impossible to create without destroying large parts of the Cuypers station. Therefore, the creation of the desired condition must be sought through other strategies.

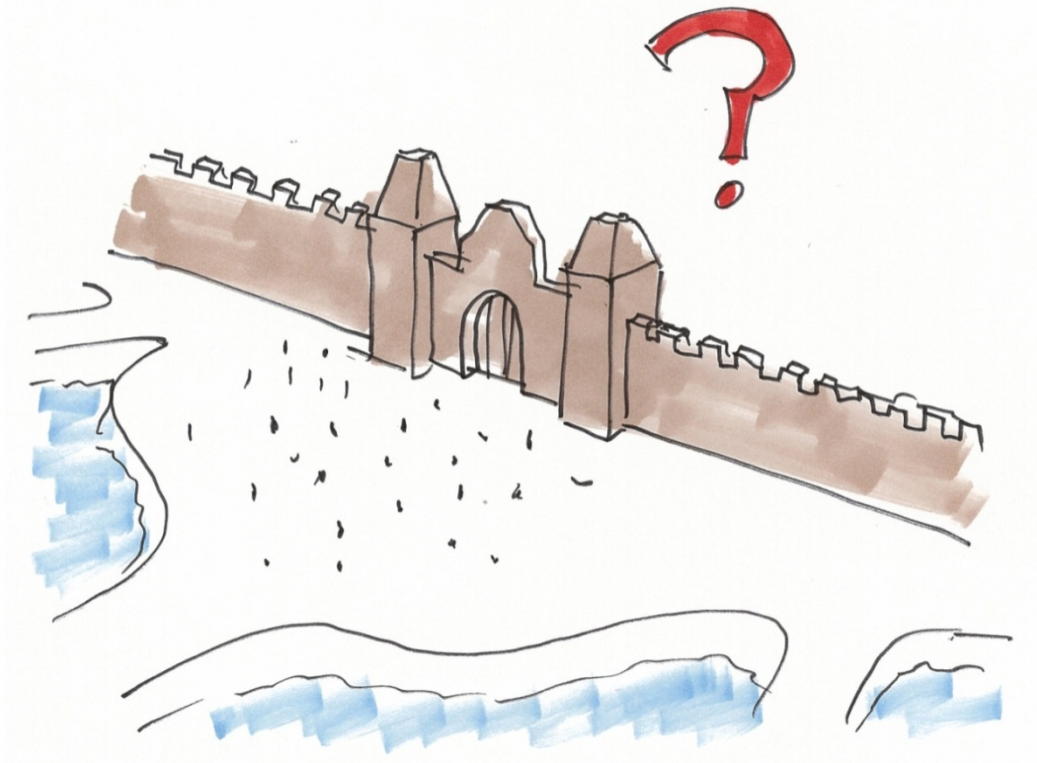

Figure 63 - Current Station as Closed City Gate

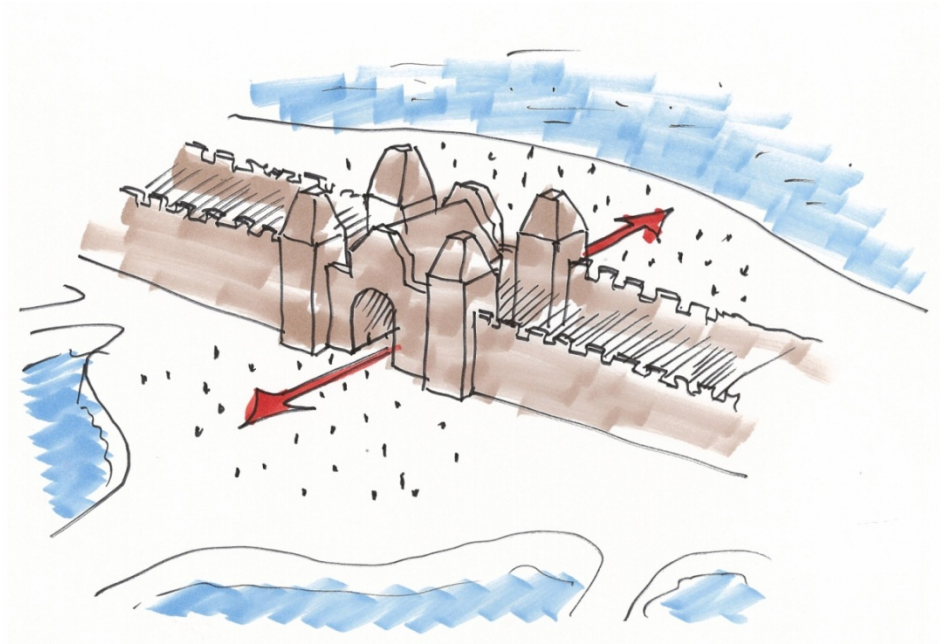

Figure 64 - Desired Condition: Station as Open Gate Leading to the Water

The strategy which this thesis has concentrated on is to focus on the central passageway underneath the tracks, and to emphasize that passage and transform it into a more civic pathway. In the existing plan (Fig. 66), the central passage feels narrow, has a low ceiling, has no end destination or view, and is insufficiently animated by surrounding program (Fig. 67).

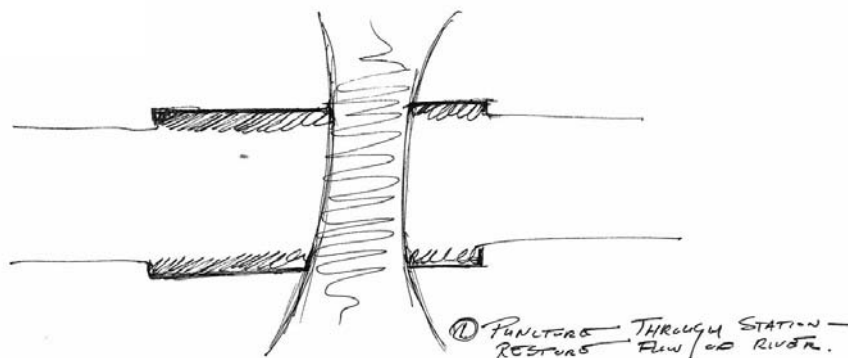

Figure 65 - Metaphorical River Through Station

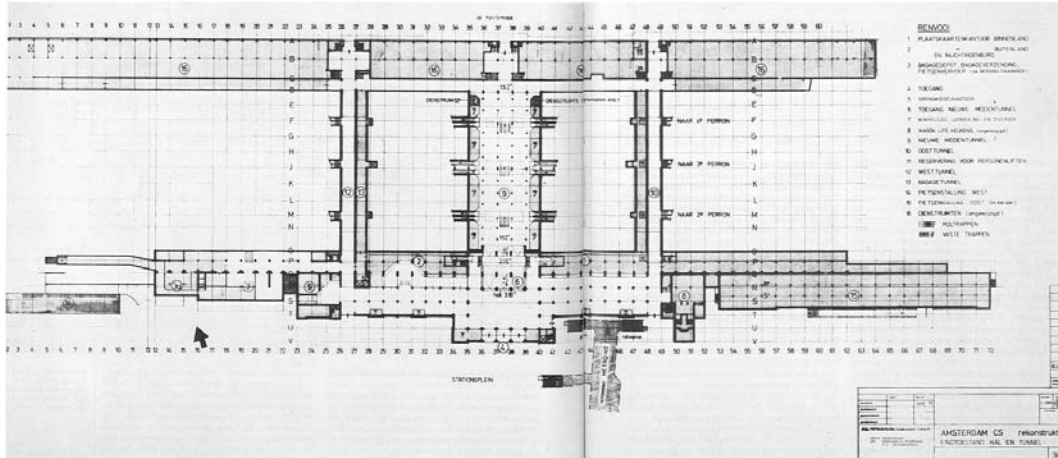
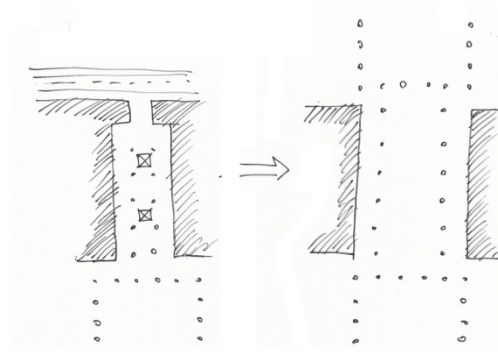

Figure 66 - Existing Station Plan (Scanned from Lansink, Lydia. Geschiedenis van het Amsterdamse Stationsplein.)

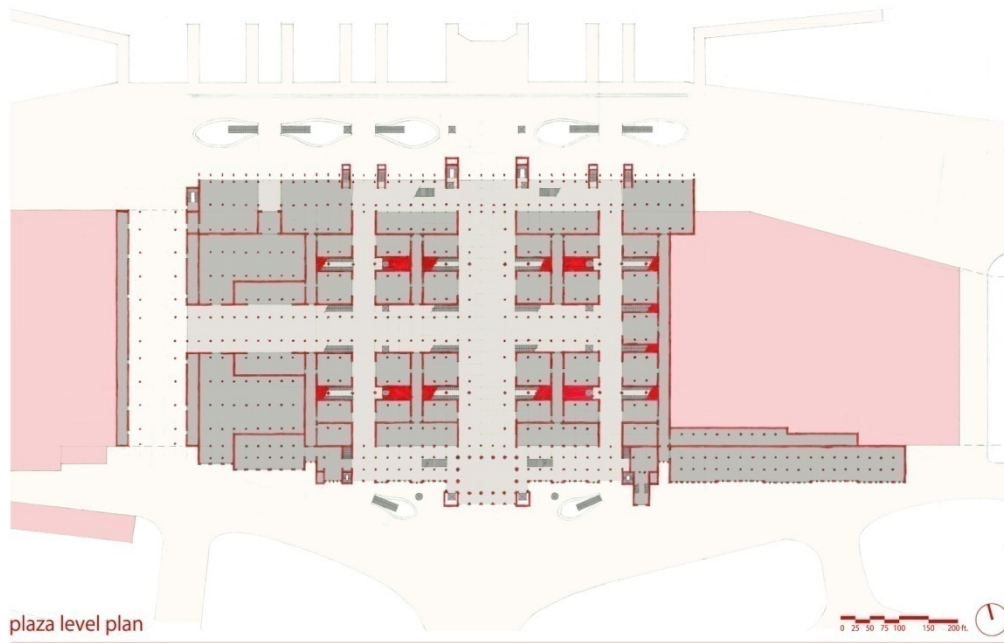

Figure 67 - Existing Central Passage

By widening the central passage, increasing the height of its section, and animating it by providing it with daylight exposure and surrounding retail areas, this space can become activated (Fig. 68-71).



**Figure 68 - Main Strategy: Widen Central Passage and Create Nodes at Both Entry Points**



**Figure 69 - Proposed New Station Plan**

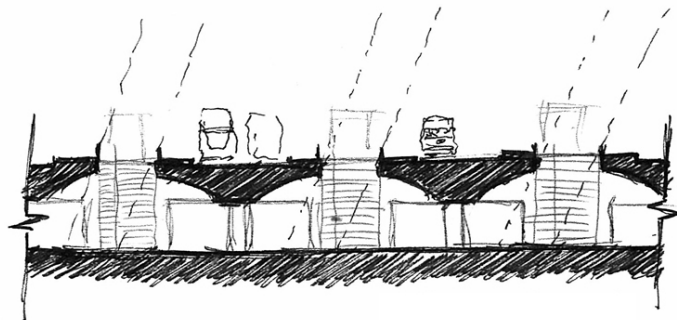

**Figure 70 - Proposed Passage Section with Daylighting**



**Figure 71 - View of Proposed Central Passage**

Equally important is the provision of a true end destination for the passage in the form of the new station hall at the waterside. Figs. 72-75 show the resulting sectional relationship provided by the proposed changes to the central passageway. From the entry to the Station Plaza at the Prins Hendrikkade, one progresses through a series of daylit spaces which are unified tectonically by their usage of vaulted ceilings. They finally arrive in light at the atrium space in the new waterside station, or *Station IJzijde*. From this hall, one can process out to the water, or from the new *Ruyterplein* at the north of the station out to the newer developments east and west of the station island, as well as across the water in Amsterdam North.

This strategy creates a significant spatial link between the city center and the water that also preserves the original building and reinforces the emphasis on its main pavilion while creating a new destination at the northern water side for one to arrive at. In this way, the connection between the city and the water has been restored metaphorically and spatially.

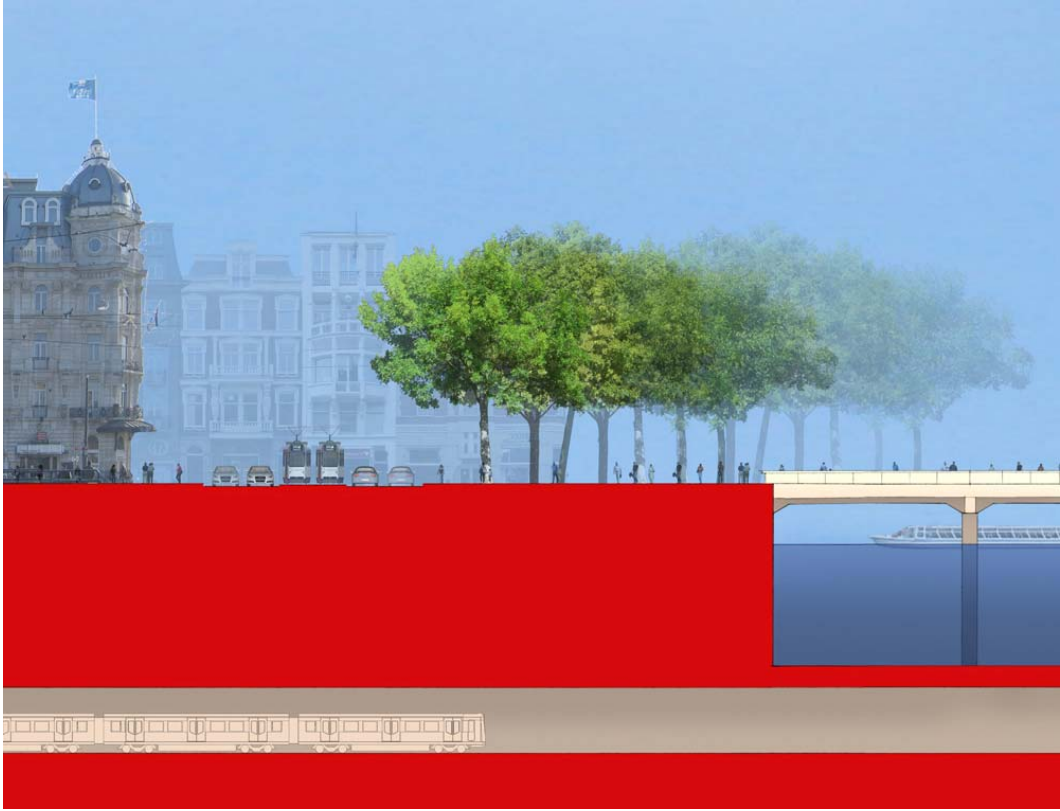

**Figure 72 - Section: Approach from Prins Hendrikkade**

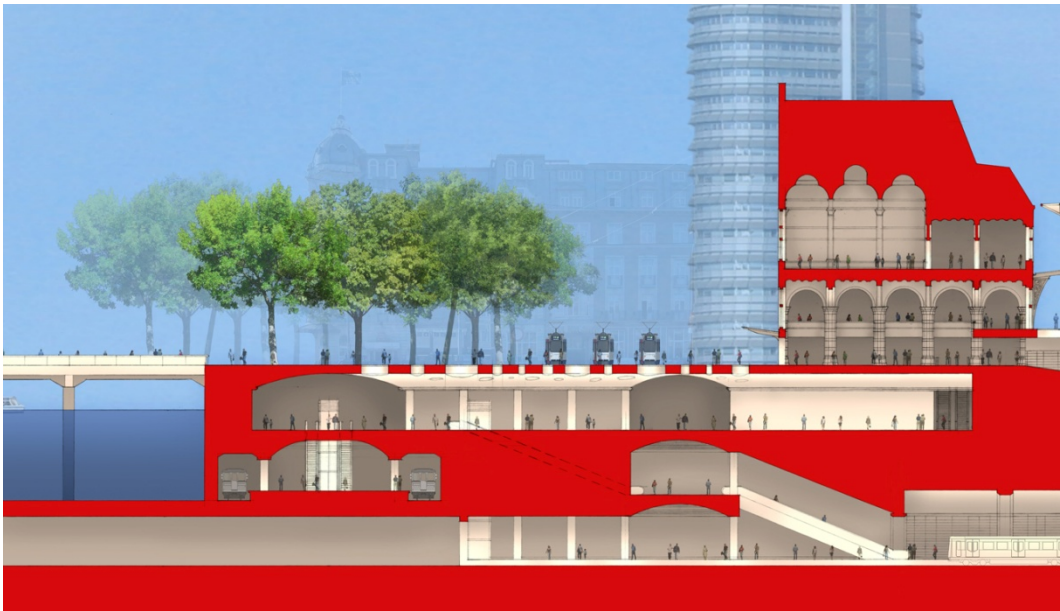

**Figure 73 - Section: Station Plaza with Restored Main Hall**

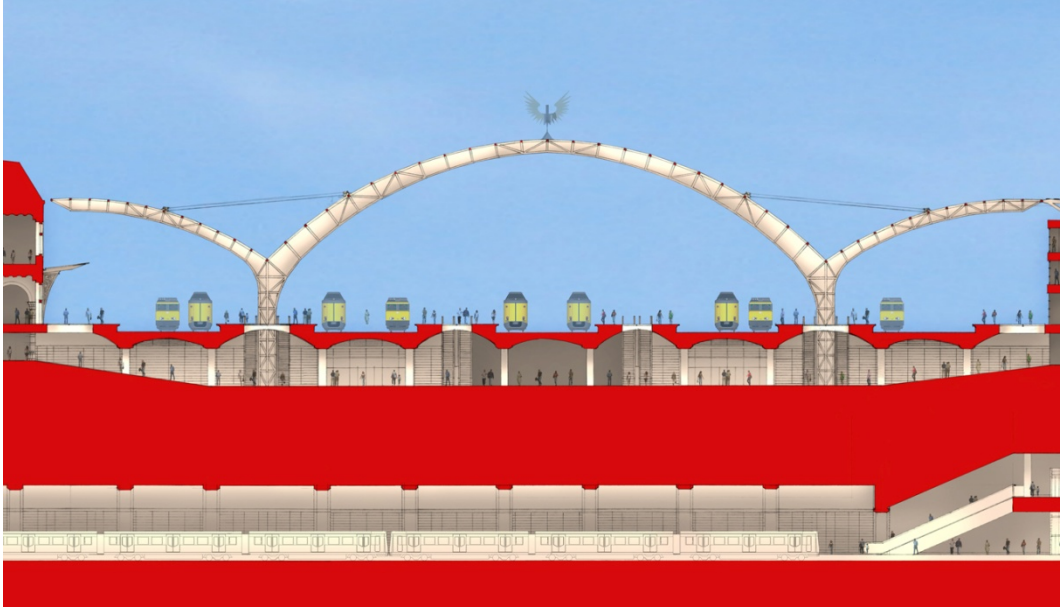

Figure 74 - Section: New Central Passage

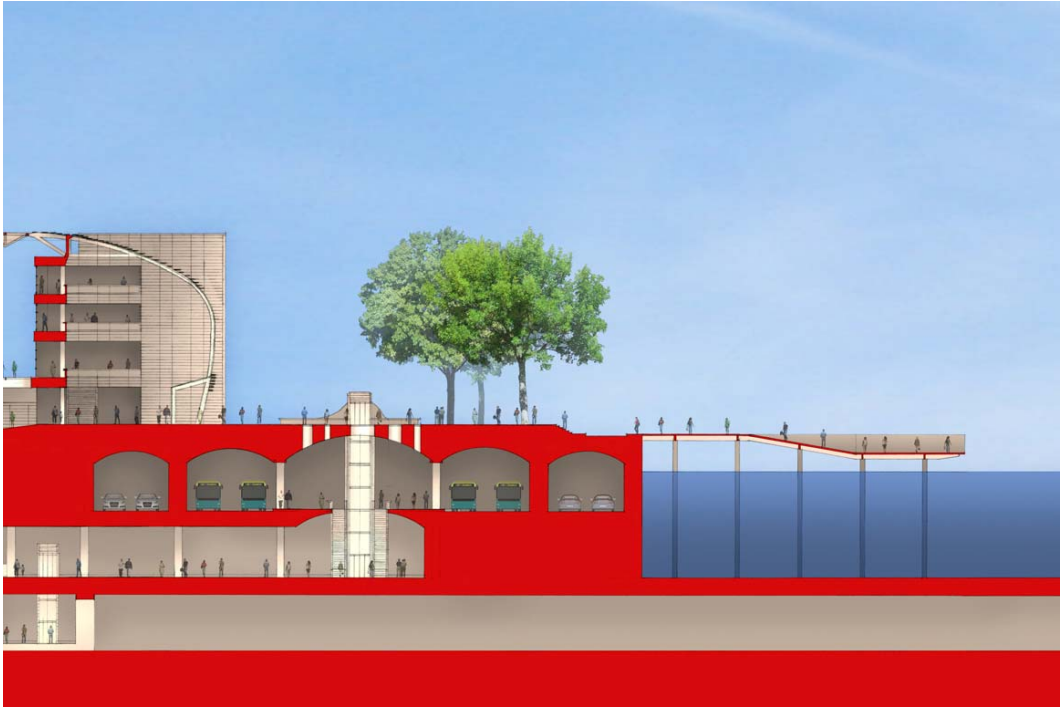

Figure 75 - Section: Waterside Plaza with New Waterside Hall

## ***The Image of the River in the City***

To reinforce the connection between city and water that has been proposed at the station island, this thesis also proposes several small interventions within the city fabric. Fig. 76 shows these areas in dark gray, overlaid over the original path of the Amstel River in blue. As discussed in the Site Analysis section, the river originally ended at the station island, and so part of the importance of the spatial connection in the station is the metaphorical restoration of the flow of the river out to the waters of the IJ.

As the river has largely been covered over and hidden within the center of the city, this layer of history has become difficult to read. To reintroduce a more powerful reading of this history, this thesis proposes interventions at four areas: Station Plaza, the plaza in front of H. P. Berlage's Commodities Exchange building (*Beursplein*), Dam Square, and along the street of the Rokin.

In these areas, the areas of the pavement over the original river are to be replaced with a darker set of pavers. Some of the pavers would be glazed to be reflective, while others would be unglazed. They would be laid out in a relatively random pattern, so that the reflections of daylight or artificial light on the pavers would appear to simulate the shimmering surface of water. At the edges of this darker pavement, small reflective disks would be set in a line along the edge dividing the original and darker paving, creating a visual and perceptual boundary that marks the original banks of the river. This would further be reinforced by also lining the edge with the Amsterdam bollards (*Amsterdammertjes*), down lighting to increase the reflective effect at night (Fig. 78), and trees to simulate the typical Amsterdam street section shown in Fig. 62. By creating this additional emphasis on the river's original path and its flow through the station, these interventions aid to strengthen the spatial and experiential connection between the city and IJ.



Figure 76 - Diagram: Reinforcing the Original Path of the Amstel through Selected Interventions

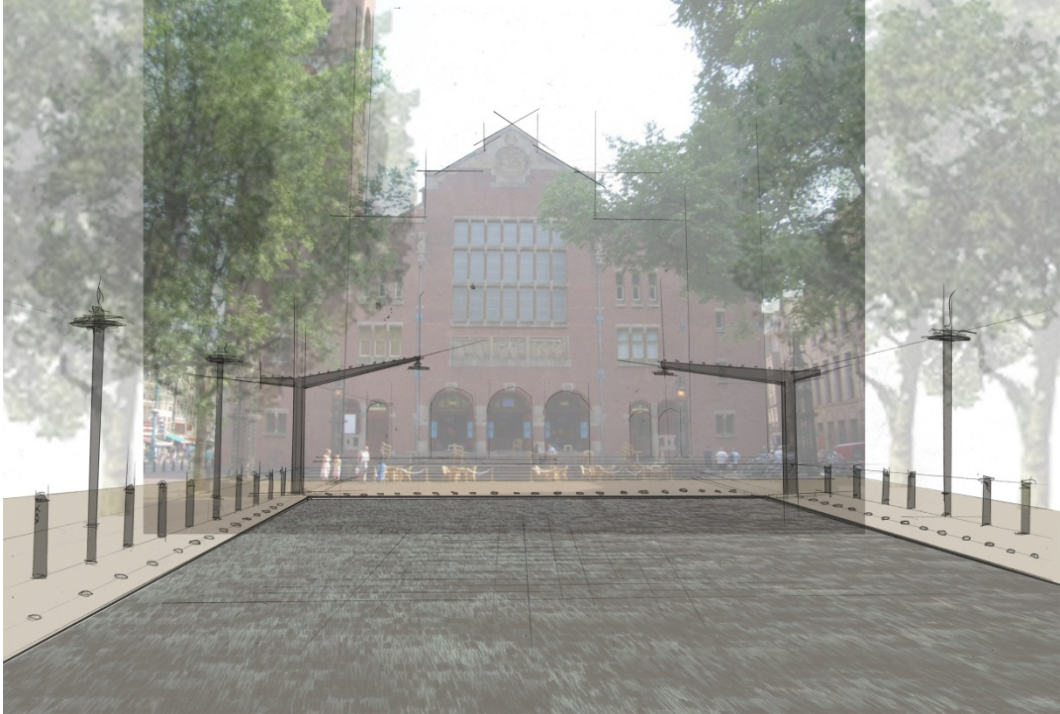

Figure 77 - Intervention Area: Beurs van Berlage (Daytime)



Figure 78 - Intervention Area: Beurs van Berlage (Nighttime)

## **Developing the Waterfront Area**

### ***Ruyterplein as New Waterfront Plaza***

The existing rear of the station (Fig. 79) is a dead space, functioning only as a connecting road between the eastern and western docklands. This space, which is easily visible from across the water in Amsterdam North, forms an essential part of the Amsterdam skyline. The space should be given a civic character and enlivened with programmed spaces. In this way, it can start to function as the new center of an area sorely lacking in both public space and landscaping (Fig. 86-89).

In dealing with transportation, it is apparent that the best way to reconfigure the bus system is to place a bus station underground at the Ruyterkade. By also sinking the normal car lanes underground, it becomes possible to create a large pedestrian area at the waterfront. The width of the underground bus station and the car lanes provides a wide enough space for a sizable plaza (Fig. 80-82).

This plaza provides ample pedestrian space, as well as two bicycle lanes near the water, which are stepped down relative to the rest of the plaza so one can sit at the plaza level and have a clear view out to the water. Landscape ideas include lining the major spaces with trees, allowing the entries to the bus station to become sculptural skylights that help to define spaces, and continuing the river paving introduced in the last section. The eastern and western ends of the plaza, which cover the entry ramps of the car and bus tunnels to the underground, could be configured either as a performance area and a market space (Figs. 83-84) or alternately they could be developed as air rights buildings (Fig. 90-92).



Figure 79 - Existing View of Ruyterkade

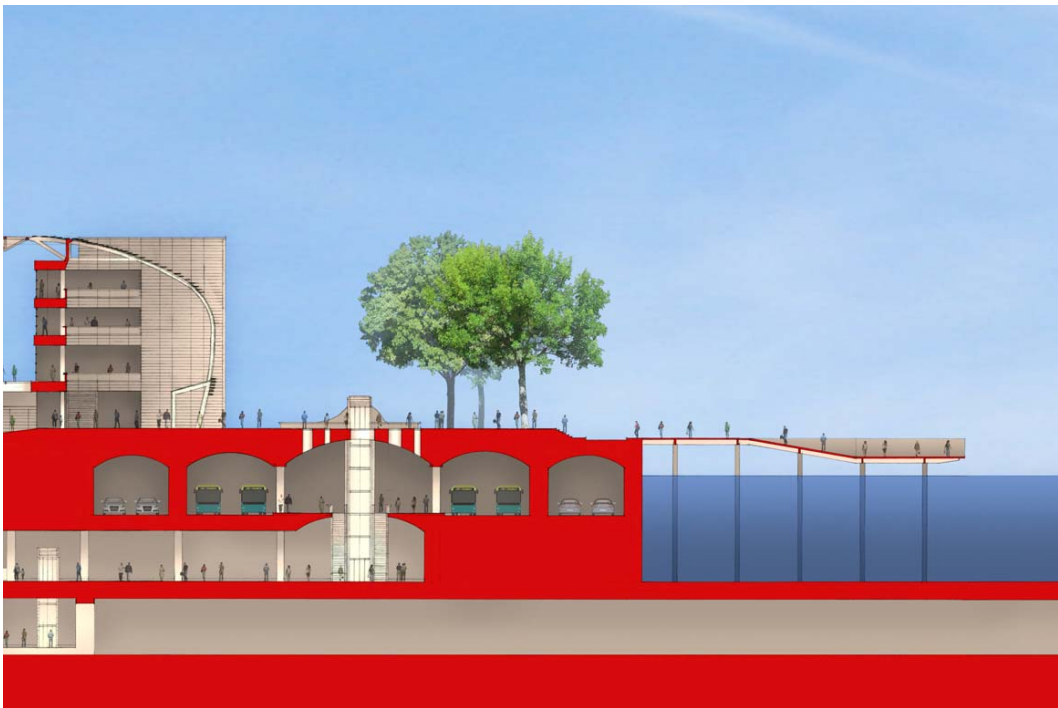

Figure 80 - Section through Ruyterplein



Figure 81 - View of New Waterfront Station Building (Station IJzijde)

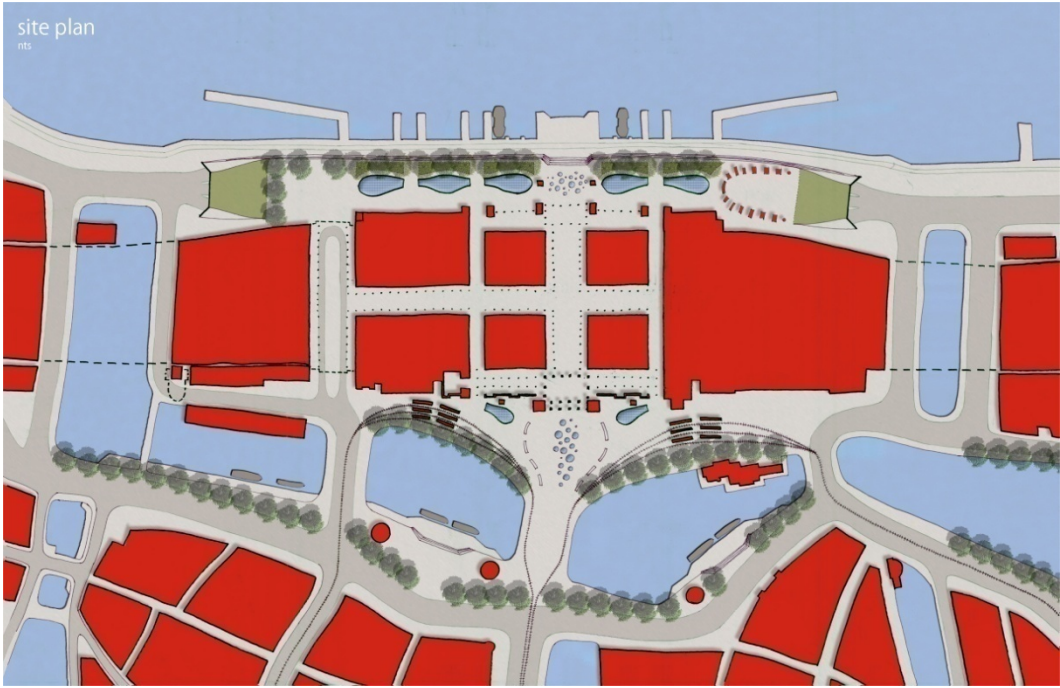

Figure 82 - Proposed Site Plan

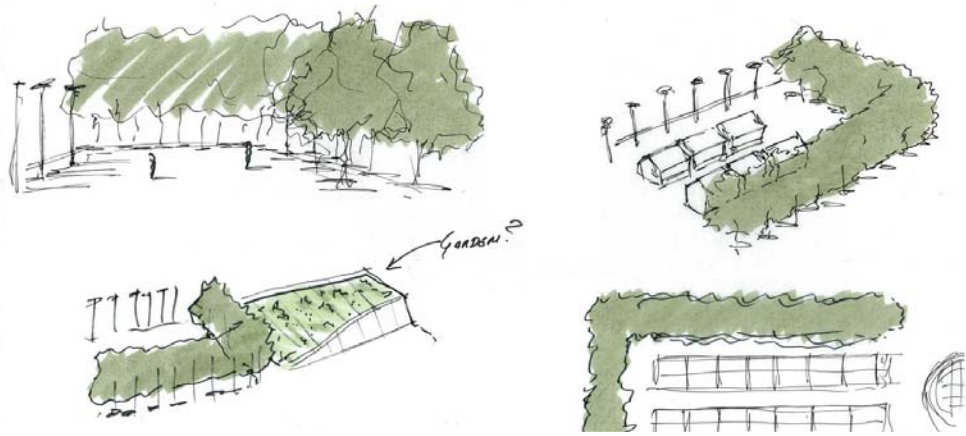

Figure 83 - Landscape Idea: Market Area at Western Edge of Ruyterplein



Figure 84 - Landscape Idea: Performance Space at Eastern End of Ruyterplein



Figure 85 - Landscape Idea: Benches on Ruyterplein

## Connections with the Surrounding Areas

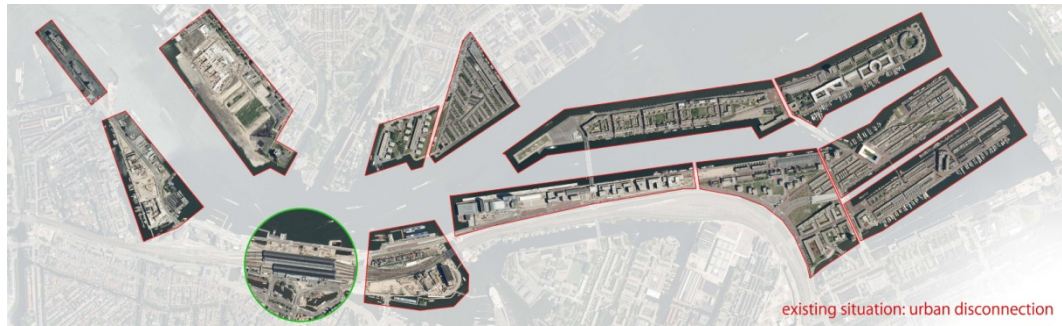

Figure 86 - Diagram: Disconnection of Urban Development Around Station



Figure 87 - Warehouse District; Lack of Groundscape



Figure 88 - Warehouse District; Lack of Groundscape

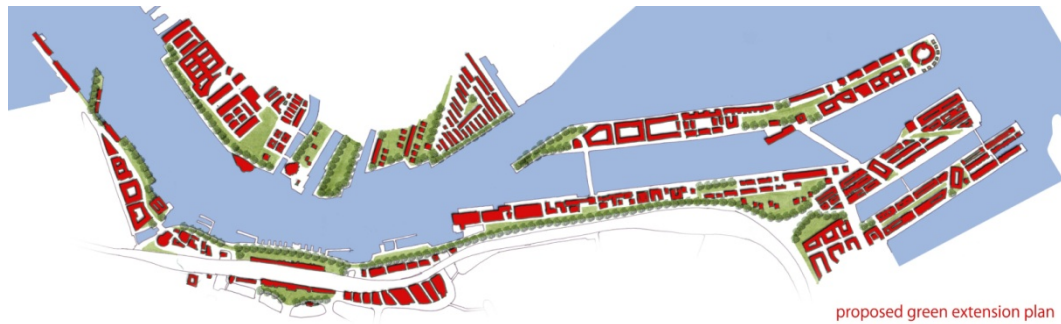

Figure 89 - Proposed Diagram: Station as Generator for New Green Edge

### *Further Development Ideas*

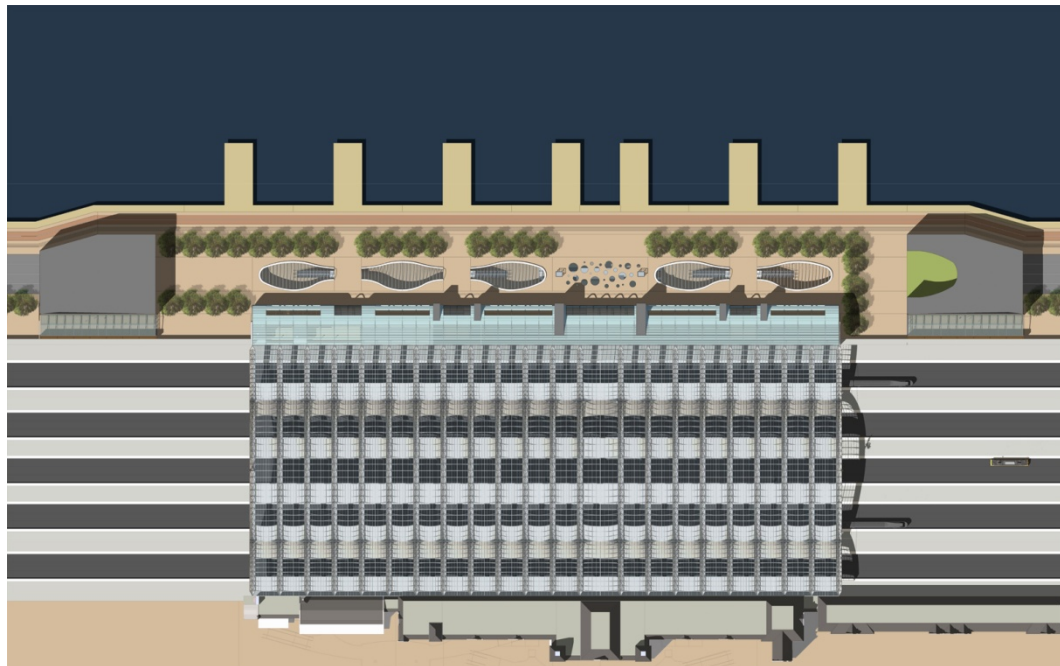
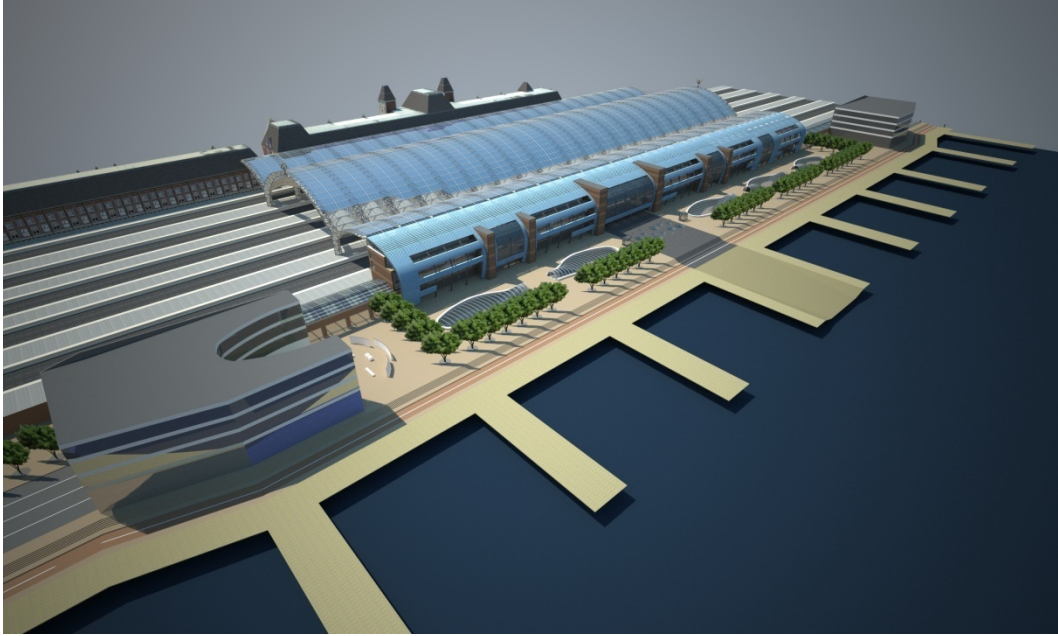
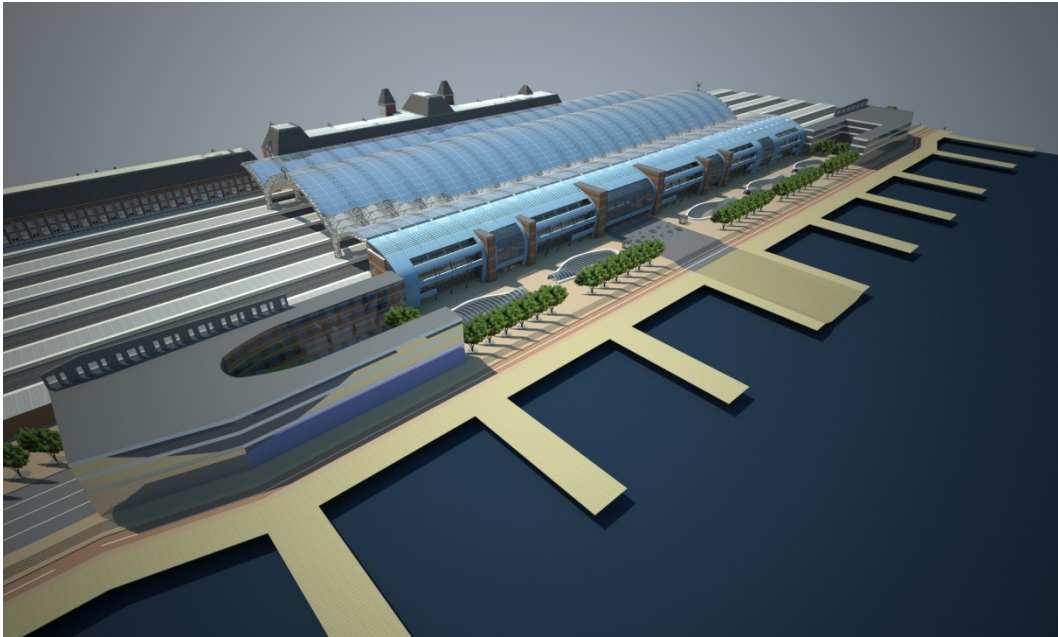

Figure 90 - Expanded Site Plan for Ruyterplein

These figures show the development of the eastern and western ends of the plaza as air rights buildings. Note that the setbacks of each building from the walls of the train emplacement create passage spaces on both ends of the plaza, which become the main pedestrian entries to this area. The performance space on the eastern side is retained, and becomes embedded within the building.



**Figure 91 - Ruyterplein with Proposed Mixed-Use Buildings at East and West**



**Figure 92 - Alternate Development Strategy of Ruyterplein**

## ***Active Gallery***

In order for the passages to avoid becoming dead or intimidating places, they must be animated in some way. This thesis proposes to use these passages as open-air art galleries. They are referred to here as “Active Galleries” because the idea is that they would continuously be repainted.

The bays of the northern wall (Fig. 95), shown in plan as the “Academic” wall (Fig. 94), would be repainted in situ on a regular basis by art students from the fine arts schools in Amsterdam or by commissioned artists. Meanwhile, the southern wall, labeled in plan as the “Free” wall (Fig. 94), would be left as a blank canvas for people to write on and more specifically for graffiti to accumulate on.

The hope is essentially that people will continuously be painting in these spaces, providing a pedagogical experience as well as setting up a dichotomy between accepted academic art and less accepted street art.

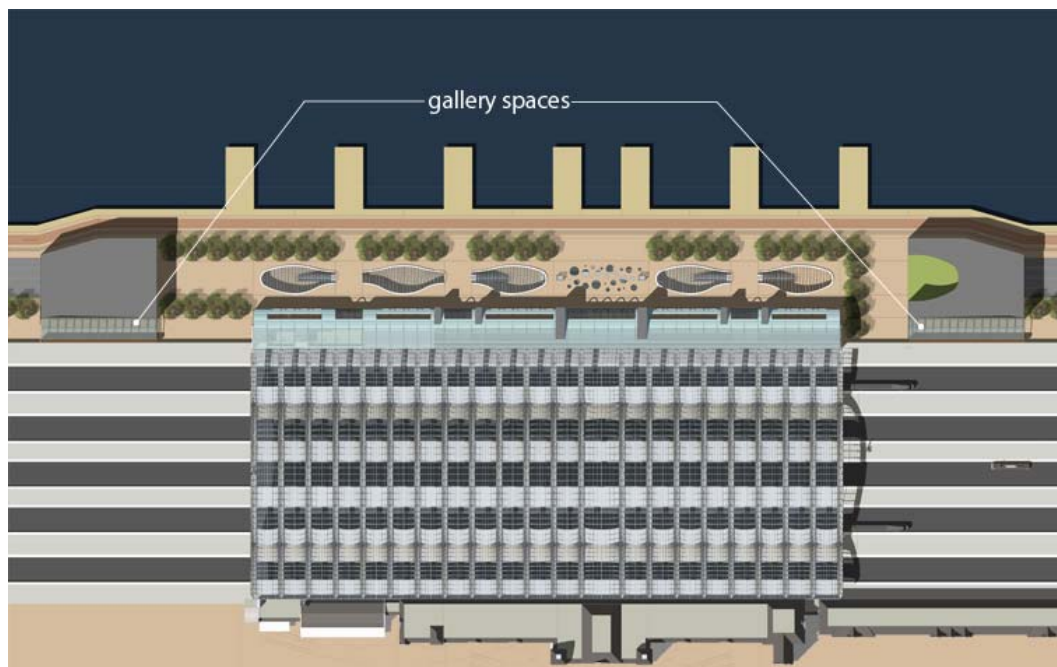

**Figure 93 - Site Plan for Ruyterplein**

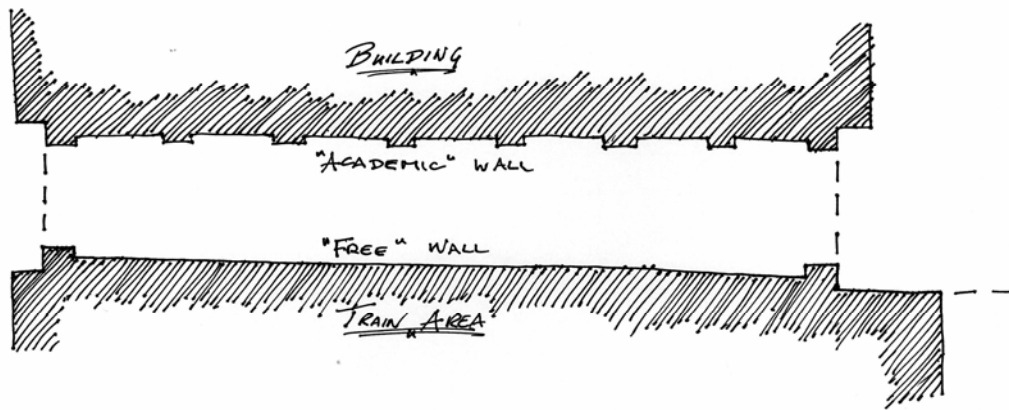

Figure 94 - Plan of Active Gallery

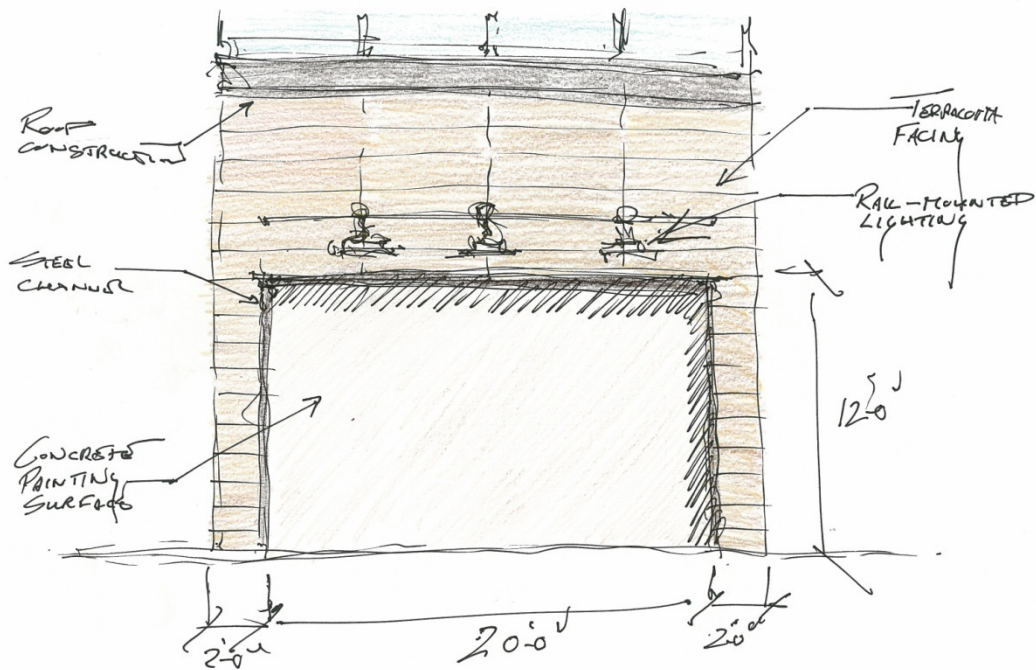

Figure 95 - Bay Detail of the Active Gallery

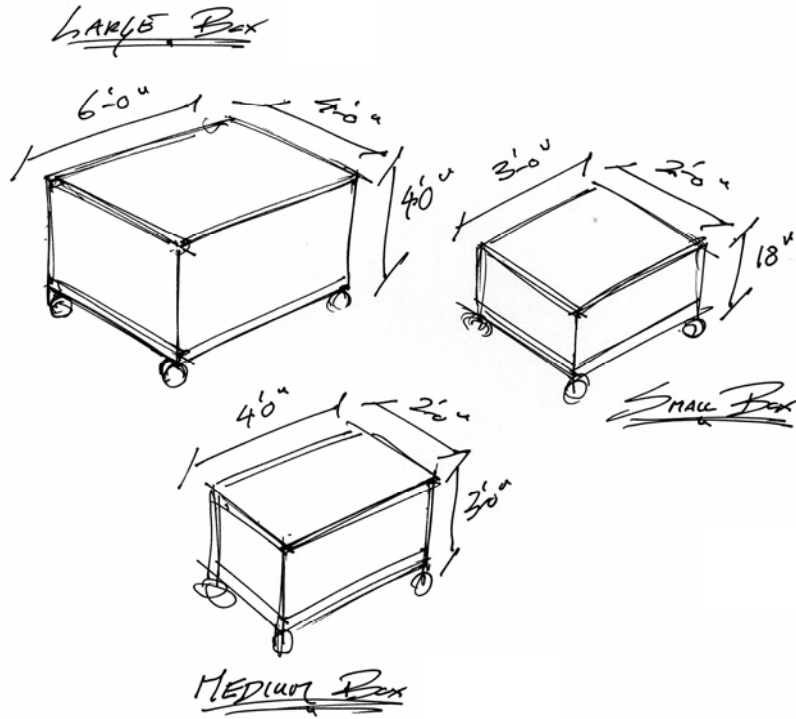

Figure 96 - Modular Boxes

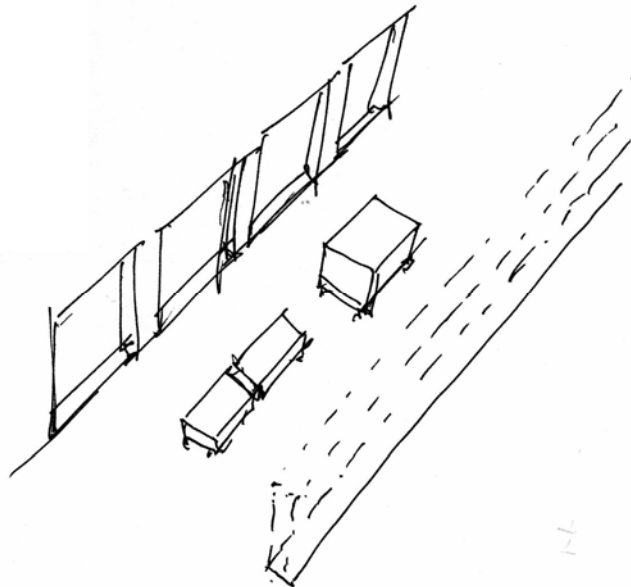

Figure 97 - Modular Boxes in Gallery Space

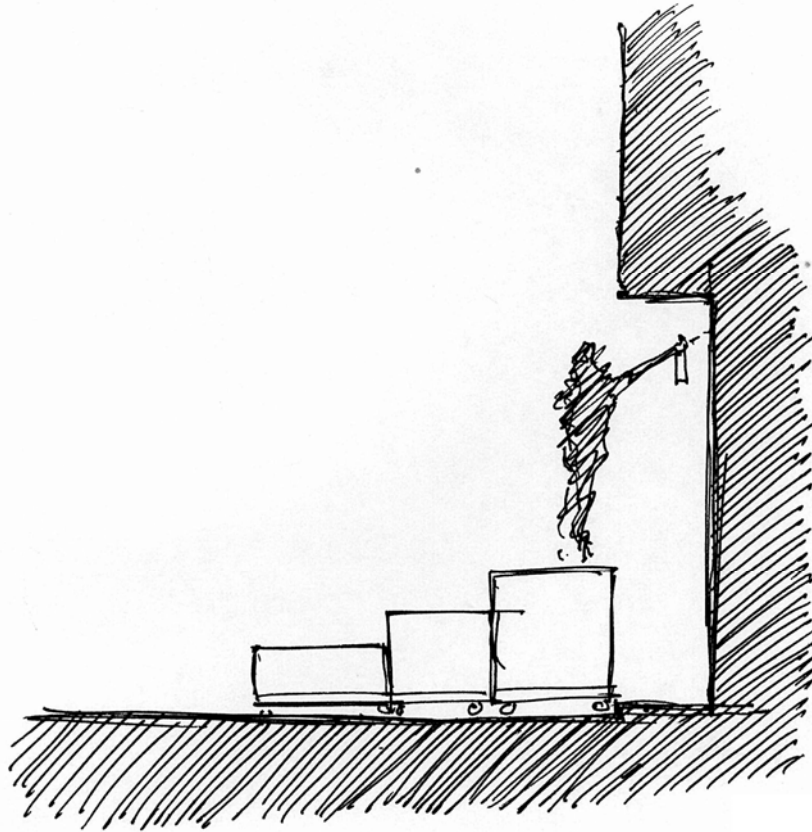

Figure 98 - Modular Boxes used as Platform for Painting

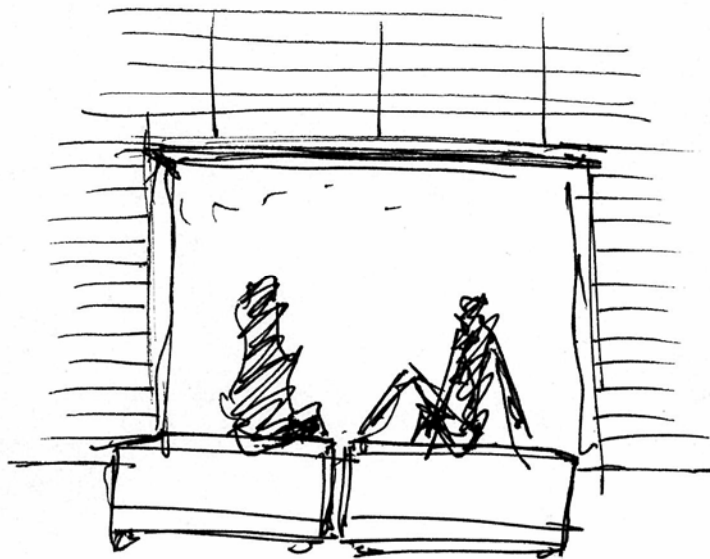

Figure 99 - Modular Boxes used as Benches



Figure 100 - Perspective of Active Gallery

**Performance Space**

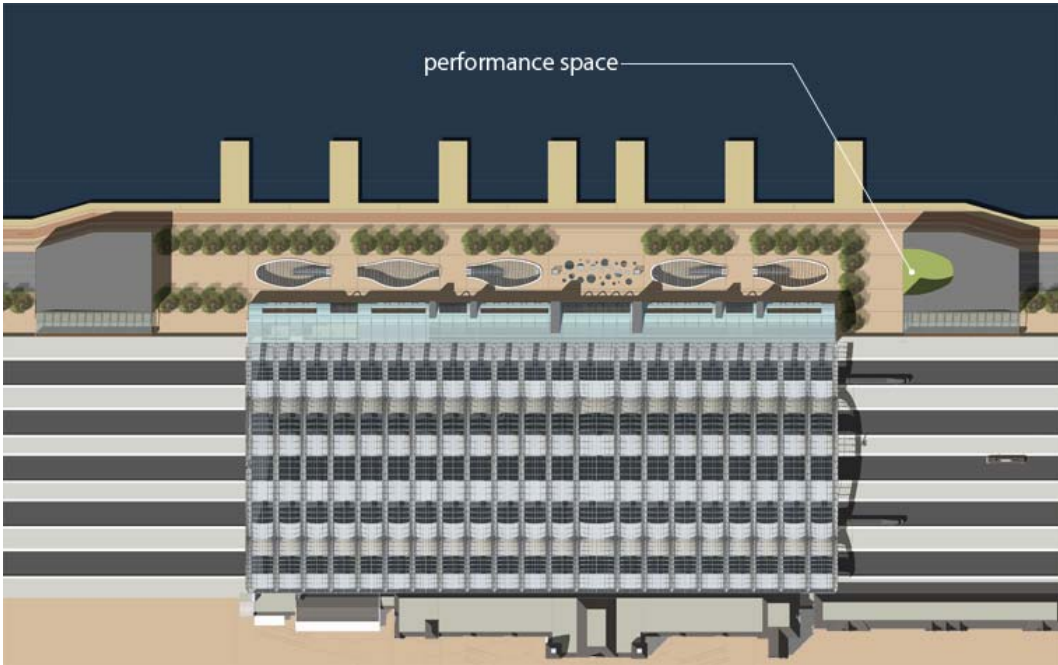
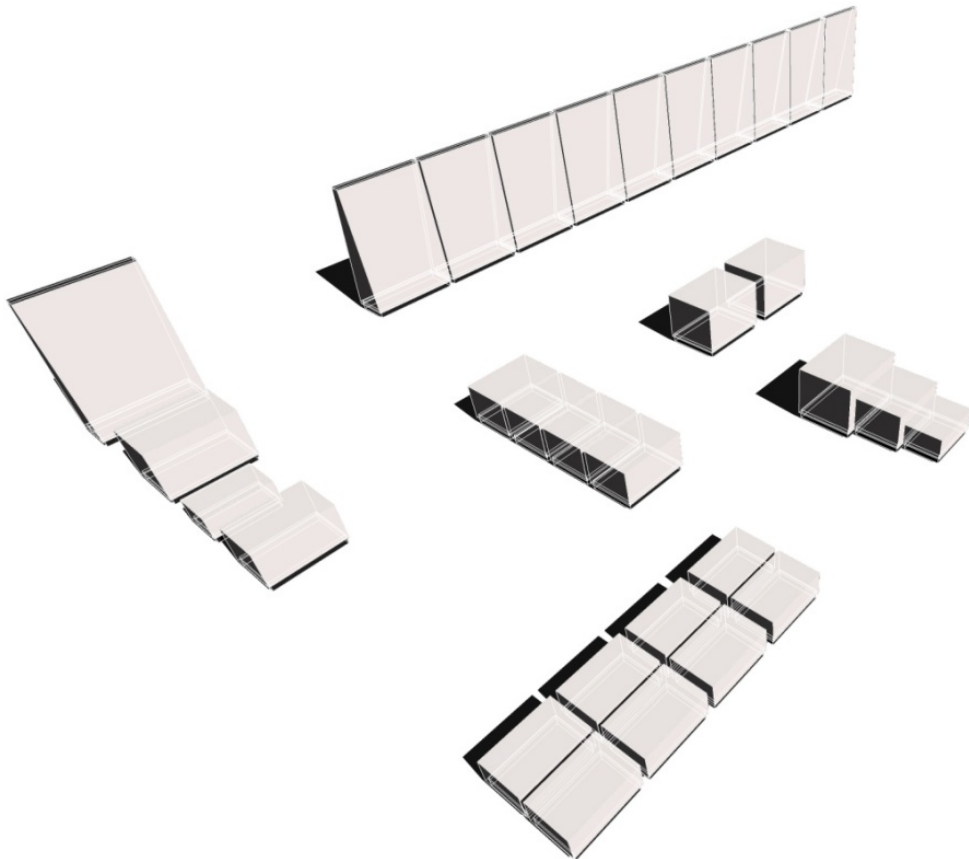

Figure 101 - Site Plan of Ruyterplein

The performance space, which here has become embedded into the building, uses the slope of the tunnel roof to create a raised seating condition. It is then framed at the western edge by a row of trees which visually screen the rest of the plaza and allow one to focus on the space itself (Fig. 106). To enhance the use of the performance space, this thesis proposes the inclusion of a series of modular units which could be reconfigured in various ways so as to create an abstract stage set (Fig. 102-104). This would allow performers to more specifically configure the space for their needs (Fig. 105) and to think creatively about how to use and respond to the spatial condition. Thus, like the Active Galleries, the performance space becomes a pedagogical environment as well as an activity node.



**Figure 102 - Modular Pieces for Performance Area**

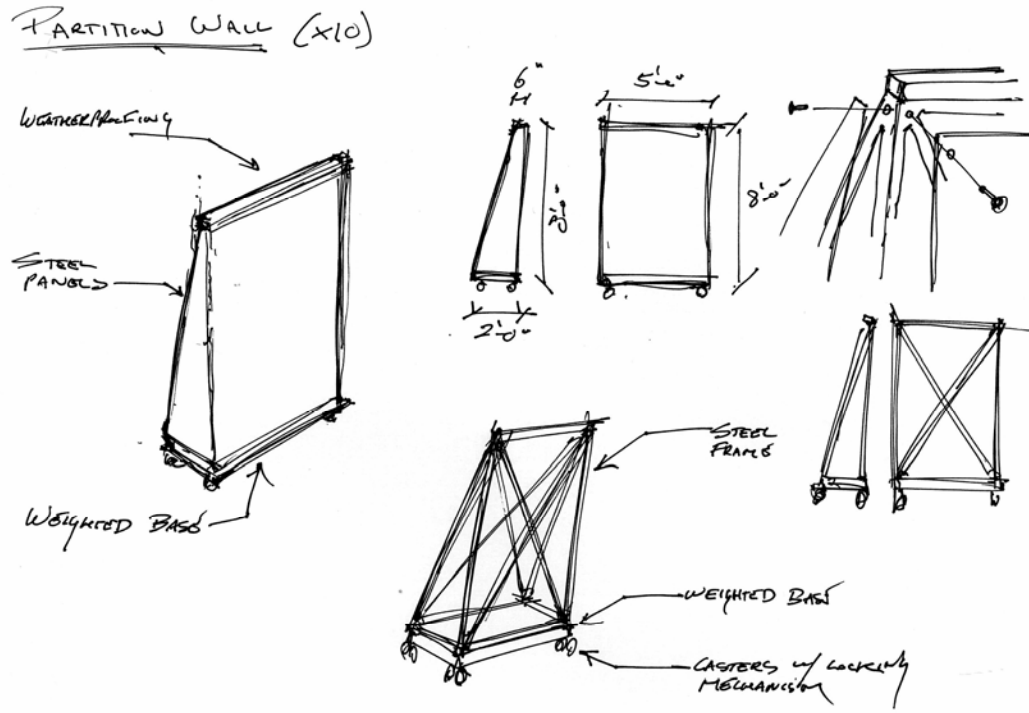

Figure 103 - Partition Module Construction Details

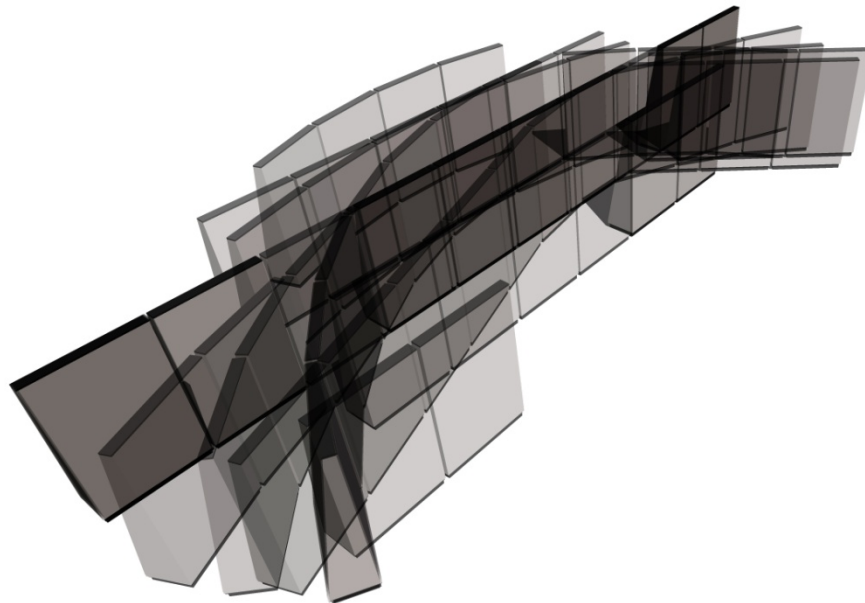
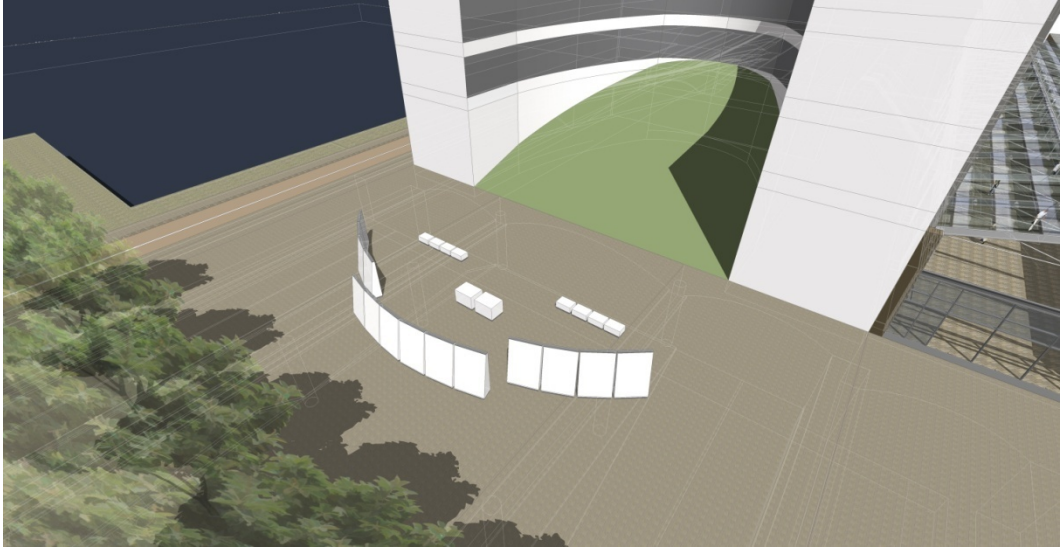
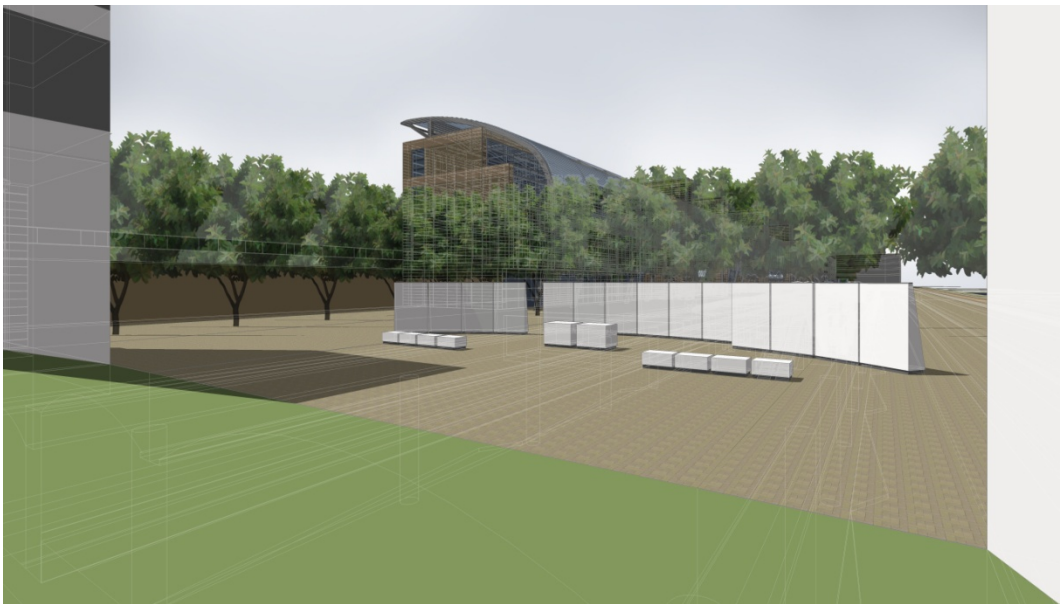

Figure 104 - Partition Module Configuration Options



**Figure 105 - View of Performance Space with Modules**



**Figure 106 - View from Performance Space**

## Reorganizing the Modes of Transport

### *The Transferia*

In placing the bus station below ground, one creates the condition of having three major underground areas; the old metro station, the new North-South Line metro station, as well as the bus station. To tie these together, this thesis proposes the creation of two areas to tie together the three underground areas to each other and to the above ground transport modes (Figs. 114-120). These areas are referred to as Transferia, or more specifically Transferium A (South) and Transferium B (North).

By moving the bus traffic underground, Station Plaza can be cleared of all transport but trams, which allows the space to become cleaner and less cluttered than it currently is (Figs. 107-109). Taxi services are relocated to a tunnel at the western edge of the station (Fig. 113), thus removing them from the plaza.



Figure 107 - View of Existing Tram Area



**Figure 108 - View of Existing Bus Area**



**Figure 109 - View of Existing Bus Area**



Figure 110 - View of Existing Metro Entrance



Figure 111 - View of Existing Metro Station



Figure 112 - View of Bicycle Flat

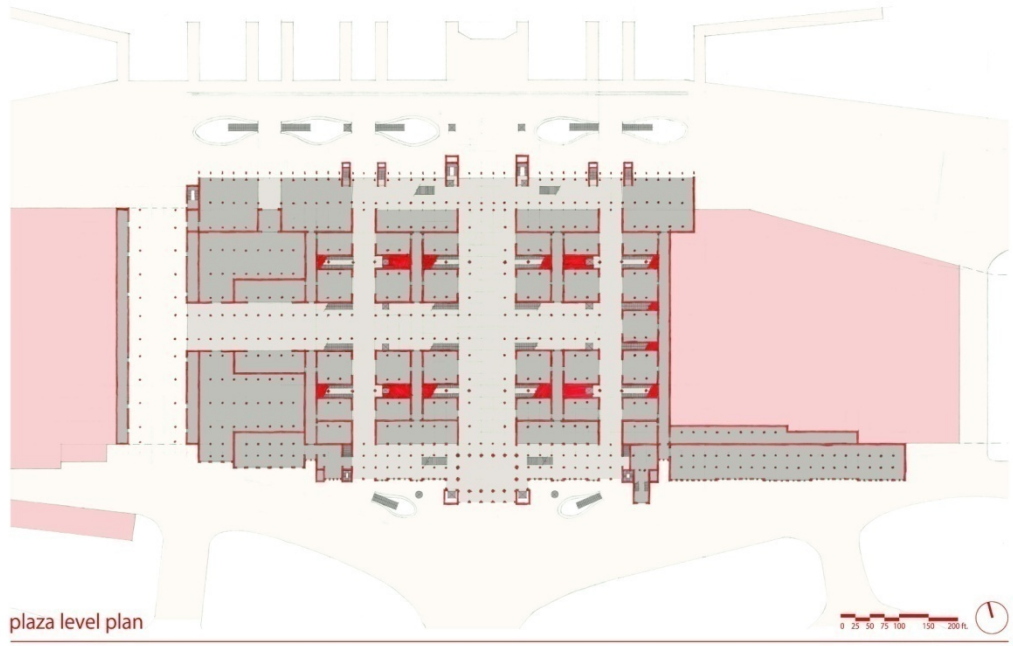

Figure 113 - Proposed Ground Floor Plan

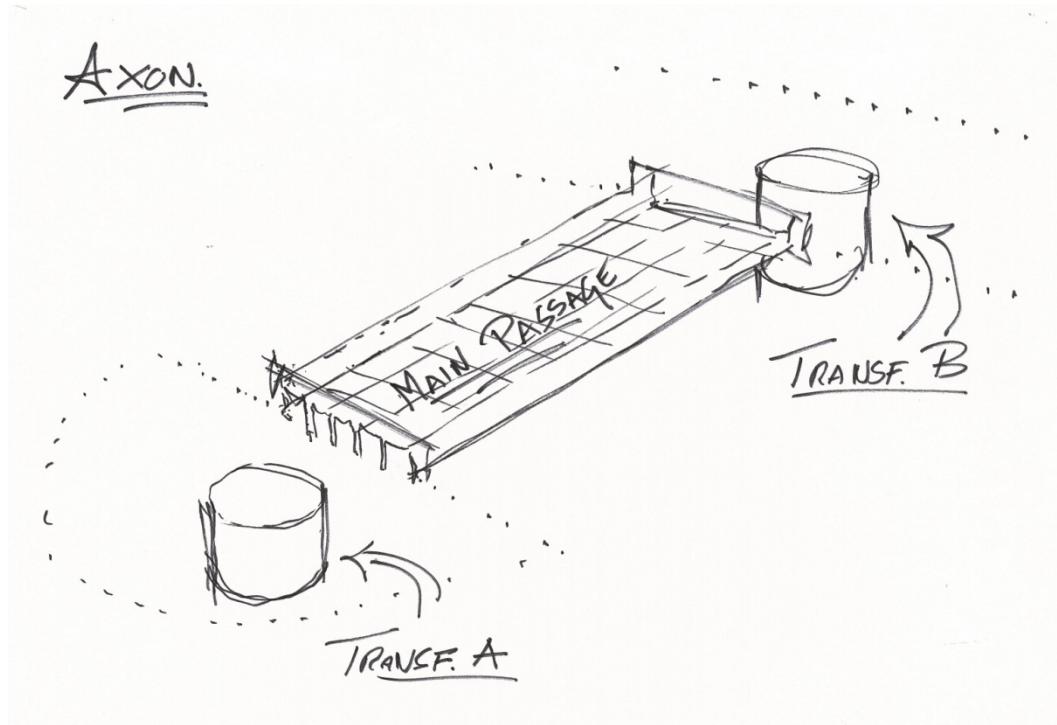

Figure 114 - Diagram: Transferia as Node Points at North and South Entrances

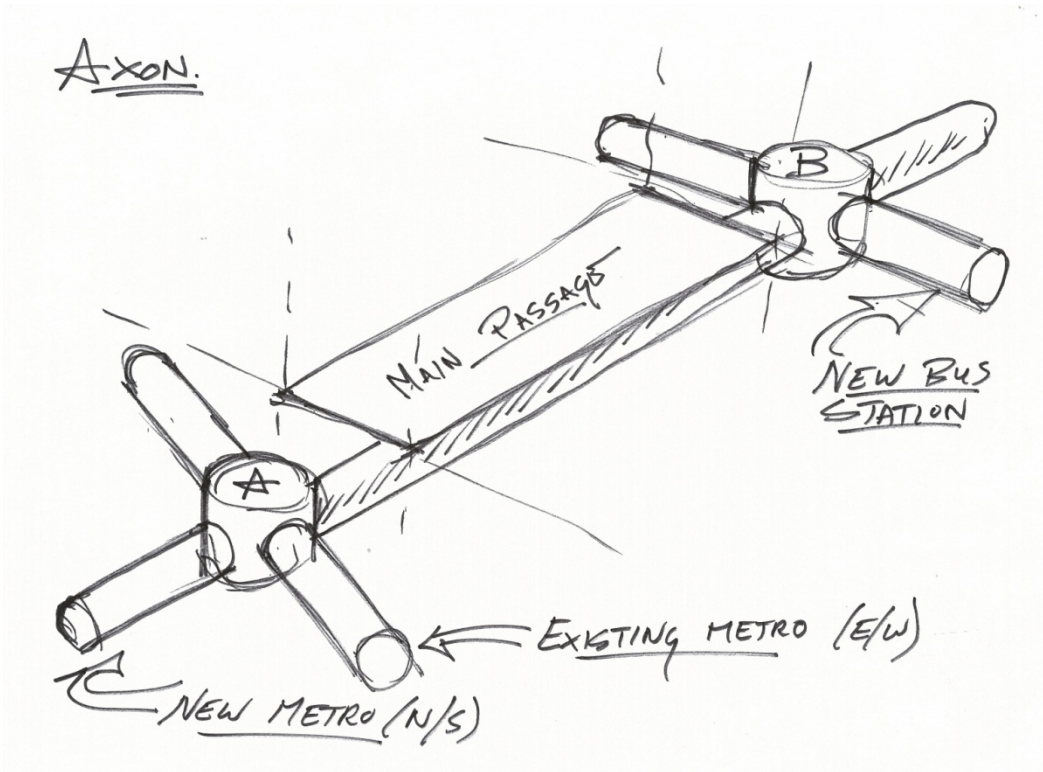

Figure 115 – Transferia

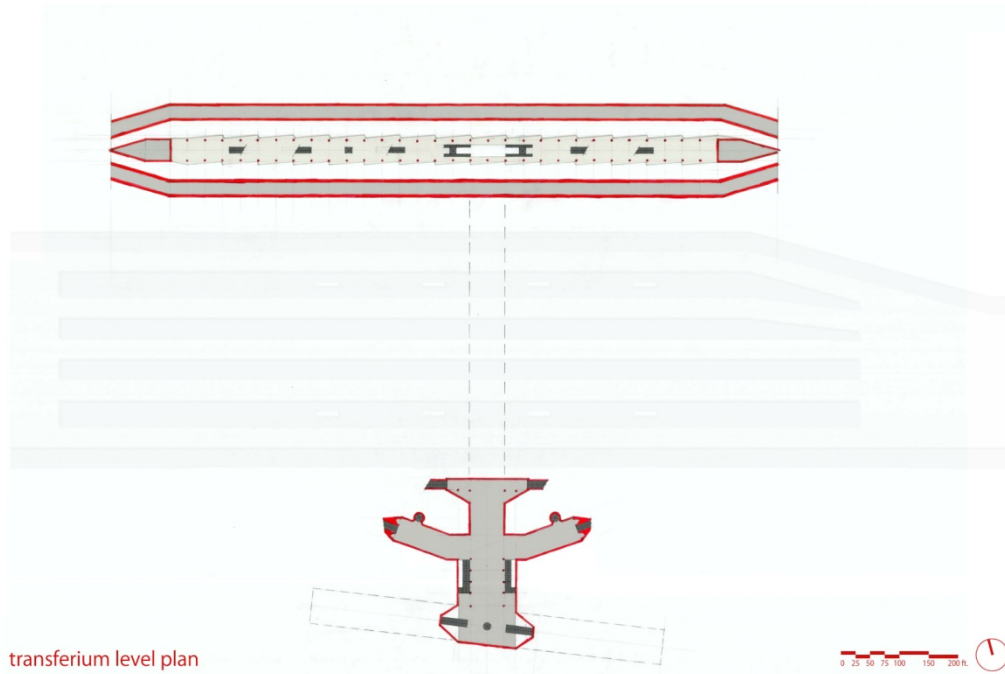
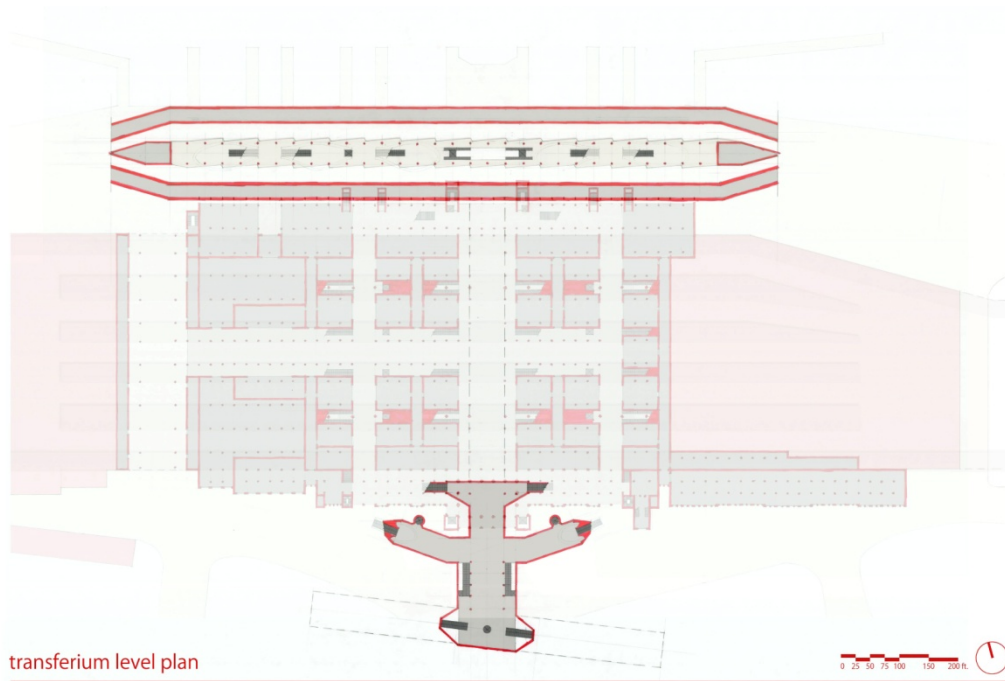
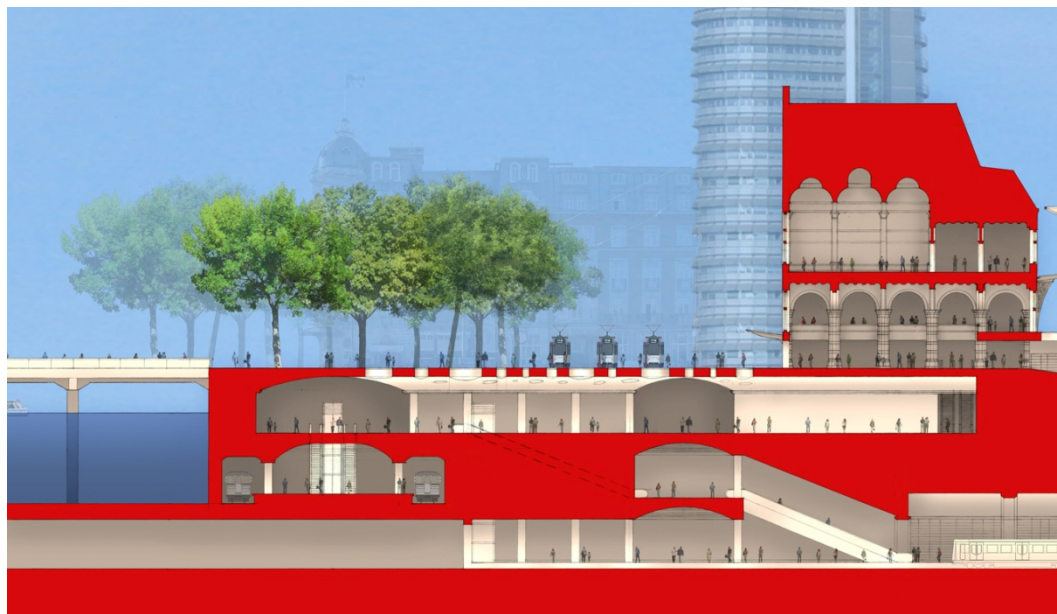

Figure 116 - Transferium Plan



**Figure 117 - Transferium Plan Superimposed on Ground Floor Plan**



**Figure 118 - Section: Transferium A**

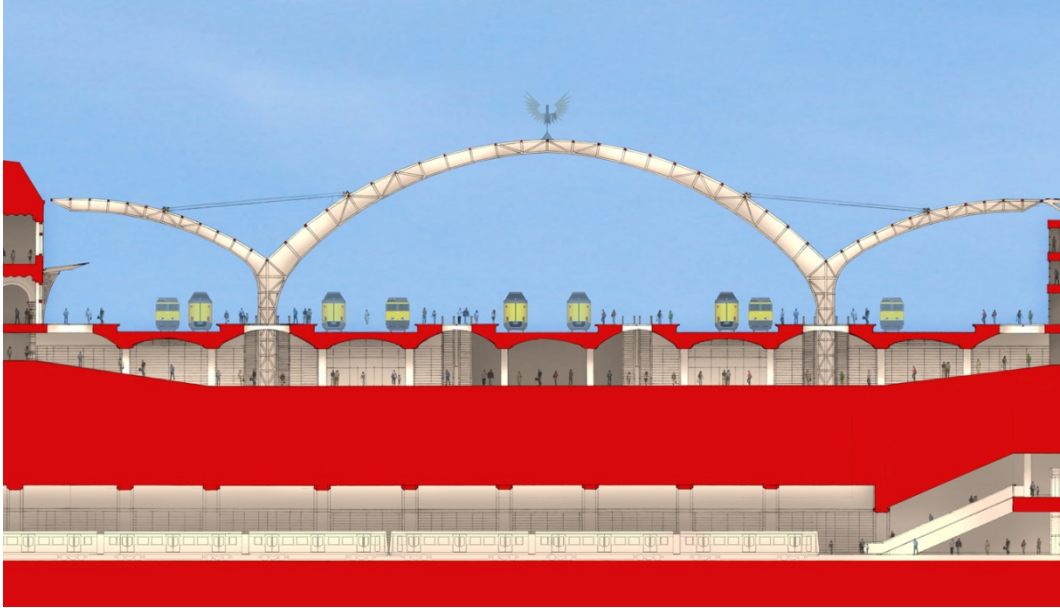

Figure 119 - Section: New Metro Station below Main Passage

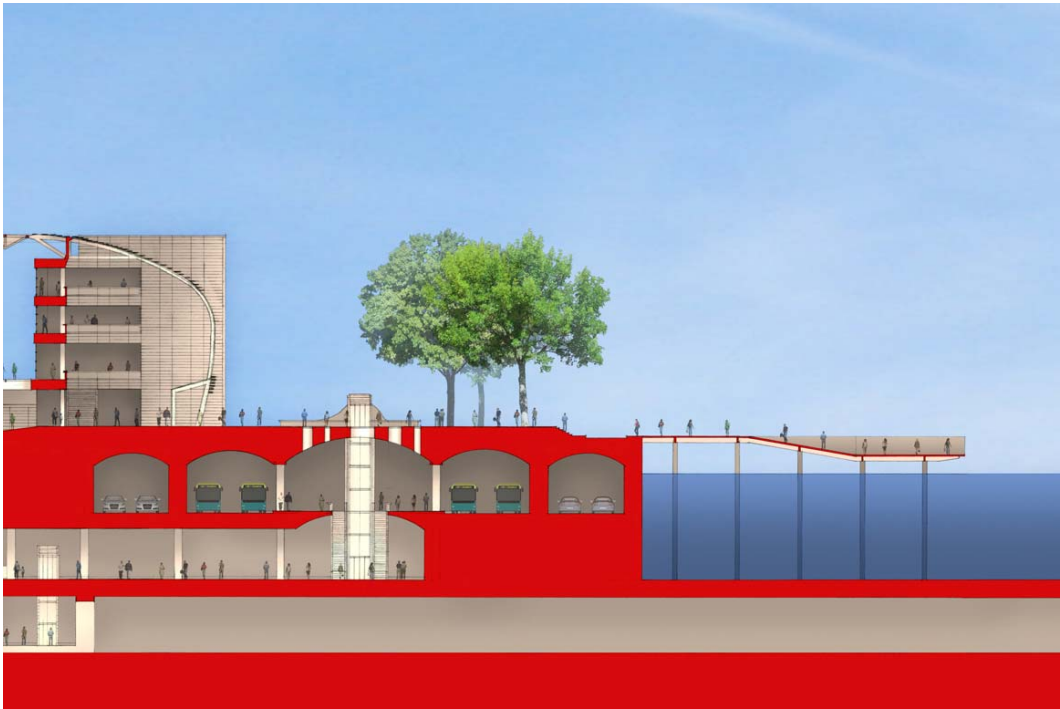

Figure 120 - Section: Transferium B

## ***Language of the Underground***

In order to tie the underground areas of the Transferia together experientially, this thesis proposes the use of a common architectonic language in both places. At the entry/exit points of both Transferium A and Transferium B, large sculptural skylights are used as entry canopies (Fig. 121, Fig. 124). These flood the space with light as well as aiding in wayfinding, as each canopy has a somewhat different shape.

The central space of both Transferia is daylit by a seemingly random collection of circular skylights (Figs. 122-123), which provide a visually interesting lighting experience. On the surface, these skylights read almost as puddles of water (Fig. 129), thus recalling their placement within the original path of the Amstel River, while below they recall the image of light entering a cave through cracks in its roof.

This controlled use of skylights creates a gradation of light as one moves through the space. From brilliant daylight outside, one proceeds first through a clearly daylit entry space, to a more dimly lit cave-like space, before finally descending to the artificially lit environment of the metro stations below. Ascending to the bus station at the other side, the space again becomes gradually more daylit, until one is outside again at the Ruyterplein.

Lastly, all of the major spaces in the underground have vaulted ceilings. This is both to recall the vaulting used extensively within the building above and to aid in wayfinding, as the direction of vaulting in each space matches the direction of pedestrian travel, thus spatially implying the correct path of movement (Figs. 122-123).

These interventions allow the different to operate and be accessed more efficiently, while clarifying the relationships between them and providing distinct spatial experiences as one moves through them.



**Figure 121 - View of Entrance/Exit from Transferium A to Stationsplein**



**Figure 122 - View of Transferium A**



view of transferium b / bus station

**Figure 123 - View of Transferium B**



exit from bus station to ruyterplein

**Figure 124 - View of Entrance/Exit from Transferium B to Ruyterplein**

## ***New Transportation Diagram***

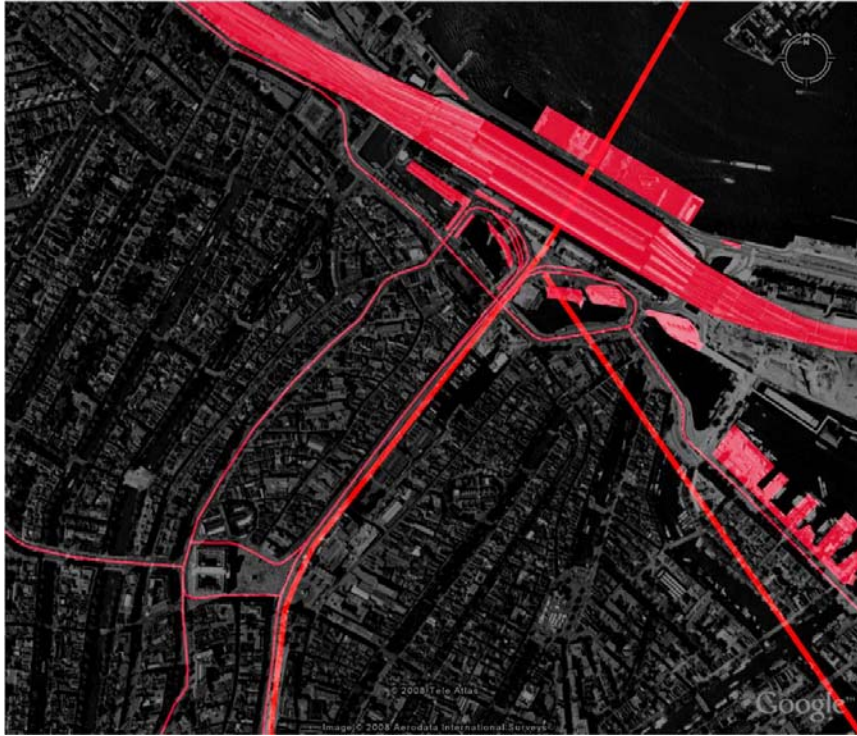

**Figure 125 - Existing Transportation Diagram**



**Figure 126 - Proposed Transportation Diagram**

## Building on the Image of the Station in the City

### *Stationsplein*

As previously discussed, the existing Station Plaza (*Stationsplein*) is too cluttered and confusing (Fig. 127). By removing all forms of transport except trams from the surface of the plaza, the plaza can be significantly improved. To improve the view of the building from the city, the tram stops themselves are moved to the edges of the Cuypers building, while the boat areas are moved across the water to the Prins Hendrikkade (Fig. 128). There, they are provided with small plazas from which one can observe the station and the water while waiting to board a tour boat. The North-South Holland Coffeehouse building, which currently blocks the view of the eastern side of the Cuypers building is also moved eastward to completely open the view from the city to Station Plaza.



Figure 127 - Existing View of Stationsplein

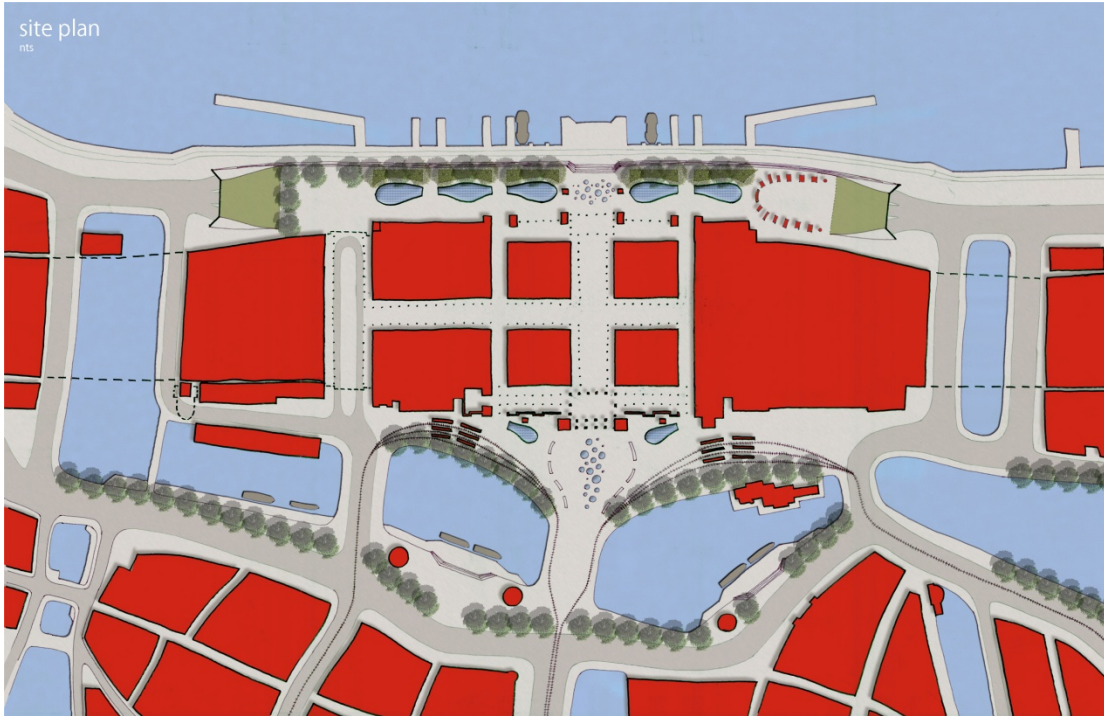

Figure 128 - Site Plan



Figure 129 - Proposed View of Stationsplein

## ***Train Sheds***

The existing train sheds are a problem for three main reasons: First, they are dark and make it difficult to bring light down to the passages beneath the tracks. Second, they are too spatially divisive, making it difficult to clearly see either the station building or the end of the shed. Third, their size and their dark color make them an intimidating and gloomy element of the skyline. In order to address these issues, this thesis proposes a new train shed, which is architecturally lighter, appears more open, brings in more light, and creates a more unified and clear spatial experience (Fig. 132-135).



**Figure 130 - View of Existing Train Shed**



Figure 131 - View of Existing Train Shed

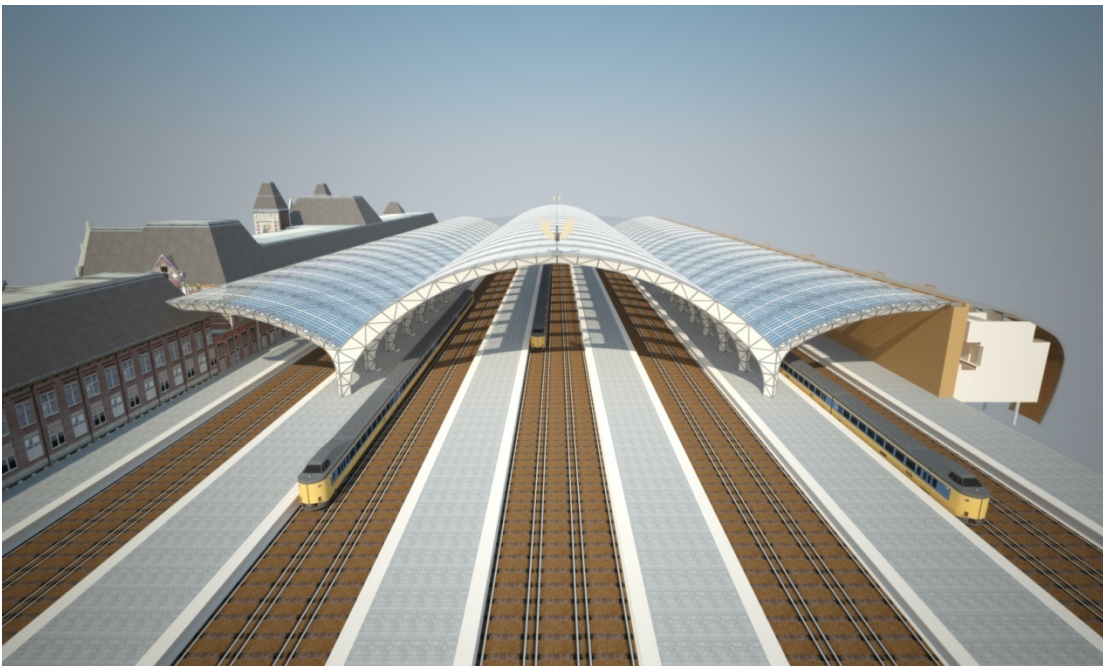
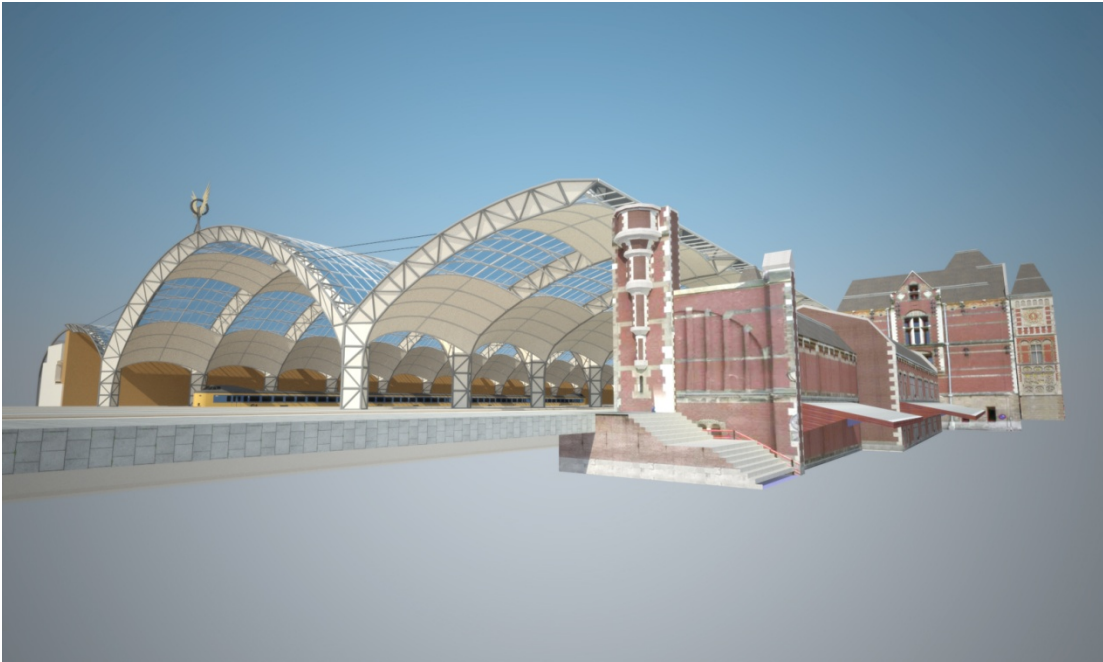

Figure 132 - View of Proposed Train Shed



**Figure 133 - View of Proposed Train Shed**



**Figure 134 - View of Proposed Train Shed**

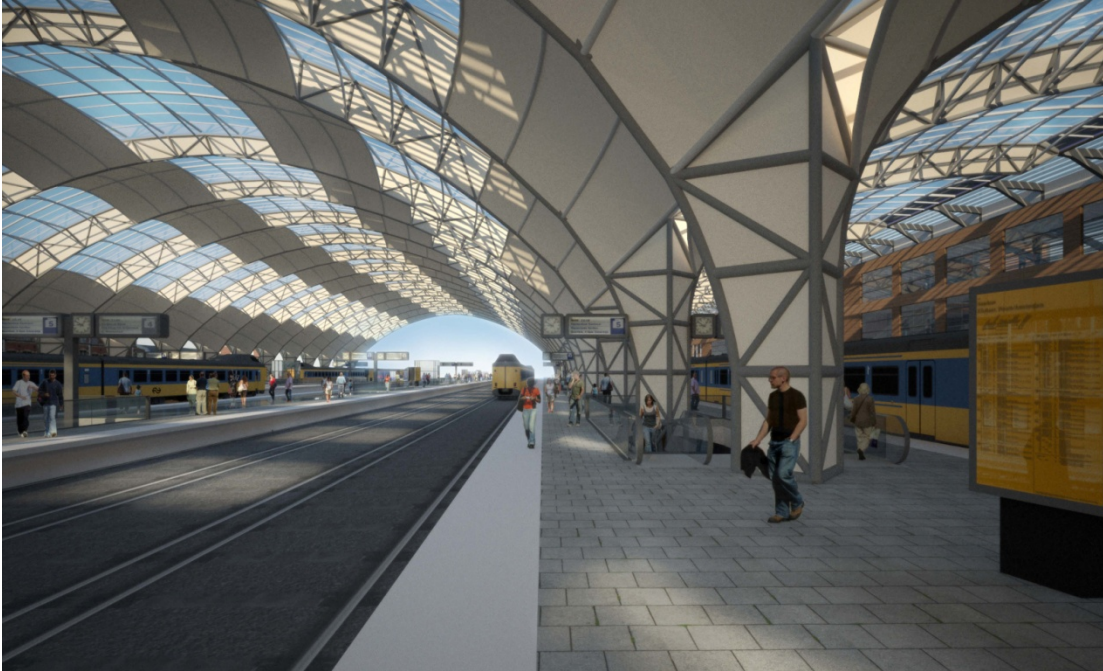

Figure 135 - View of Proposed Platform Area

### ***Station IJzijde***

The design of the new waterfront or IJ-side station (*Station IJzijde*) is a difficult and delicate task. This thesis has examined a number of different strategies to deal with this design problem (Figs. 137-146). Some of the explorations attempt to reference the original Cuypers building literally, others abstractly, and some not at all.

The final proposal (Figs. 149-153) treats the building as a completion of the geometry of the train shed and as a modern piece of the city. The Cuypers building is referenced abstractly in the bay dimensions and the curtain walls details, while the overall image provides a new image-setting element in the Amsterdam skyline. The ground floor of this building is occupied by restaurants and ticketing areas, while the first floor (at platform level) has waiting areas and the lobby of a business hotel which occupies the top two floors (Figs. 151-153). The middle two floors of the building are set out by several feet to provide a canopy at the lower level and a roof terrace for the hotel rooms at the top level (Fig. 150).



**Figure 136 - Existing View of Ruyterkade**



**Figure 137 - Station IJzijde: Proposal 1**

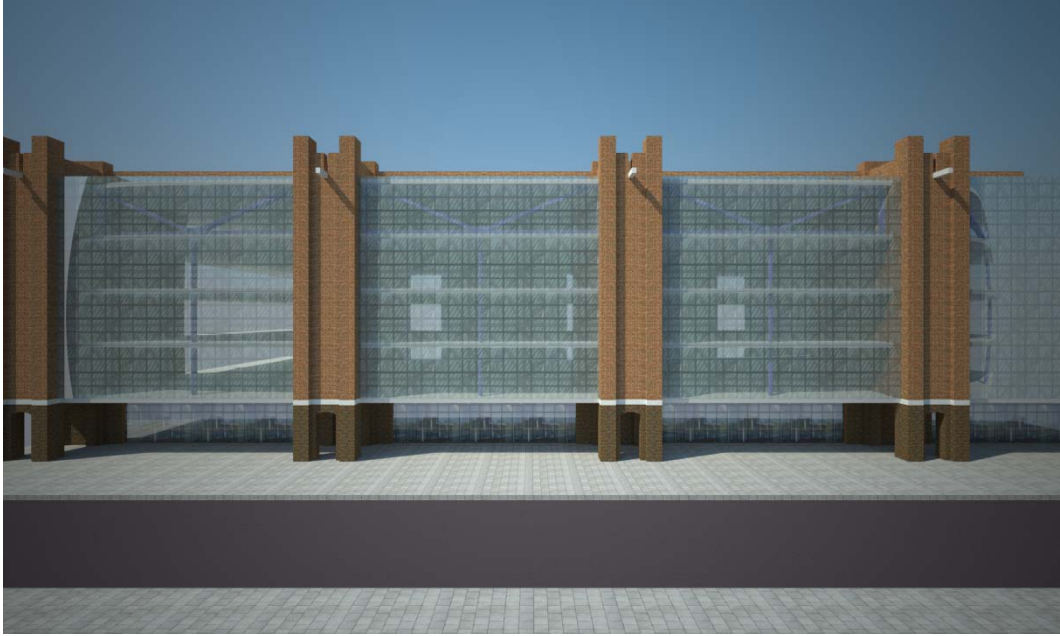

**Figure 138 - Station IJzijde: Proposal 2**



**Figure 139 - Station IJzijde: Proposal 3**

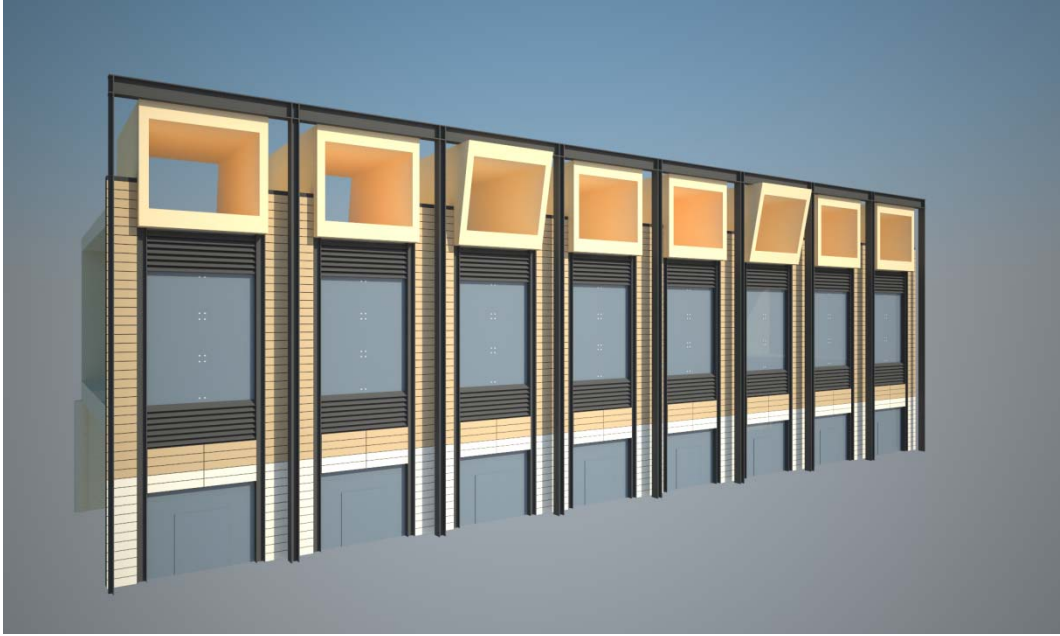

Figure 140 - Station IJzijde: Proposal 4

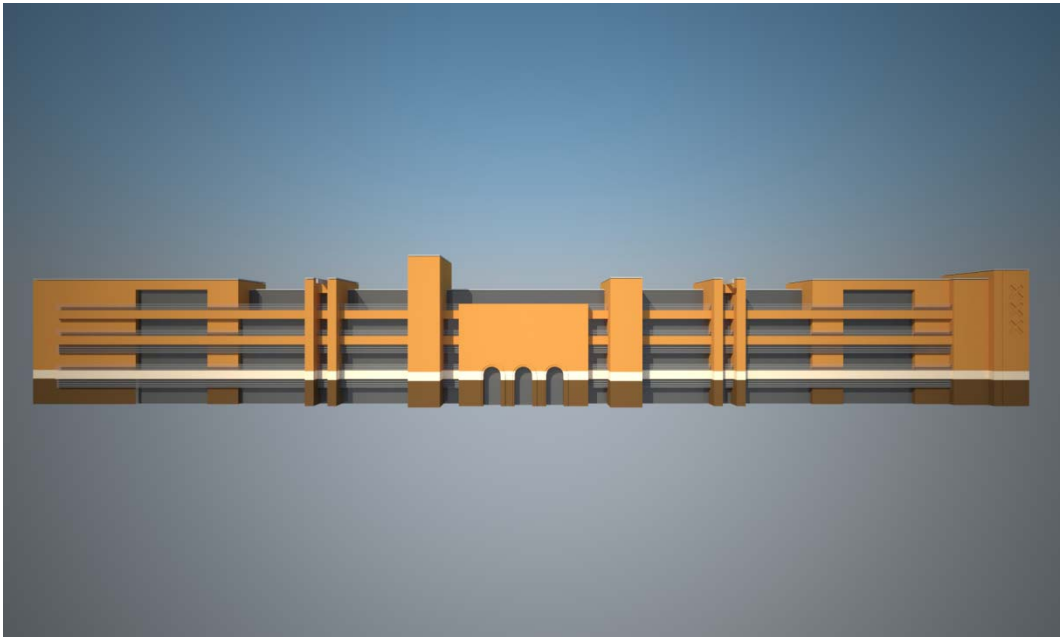
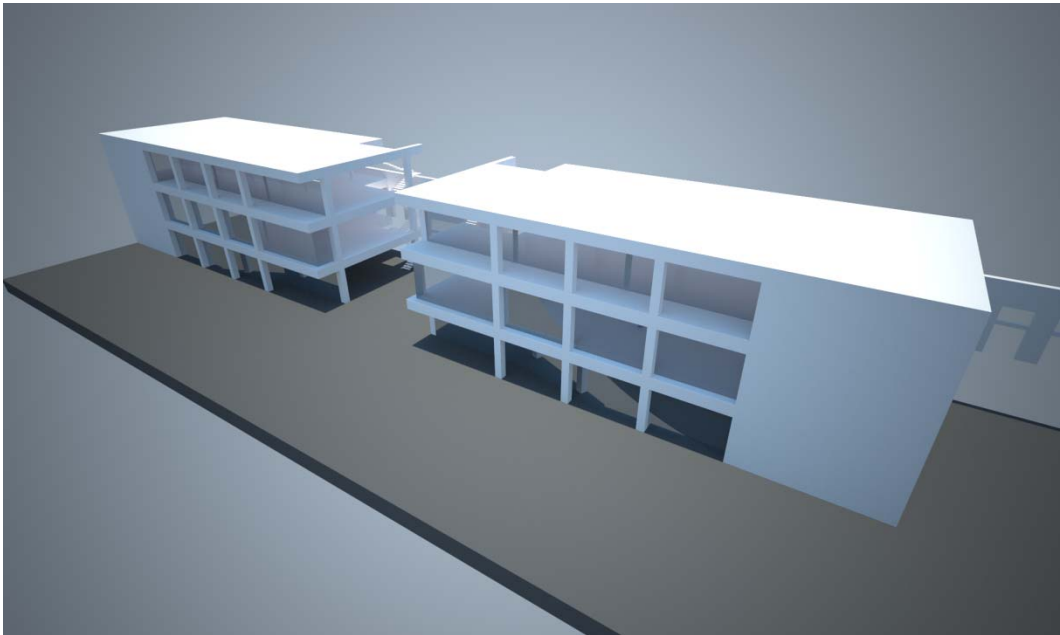

Figure 141 - Station IJzijde: Proposal 5



**Figure 142 - Proposal 6**



**Figure 143 - Station IJzijde: Proposal 7**



**Figure 144 - Station IJzijde: Proposal 8**

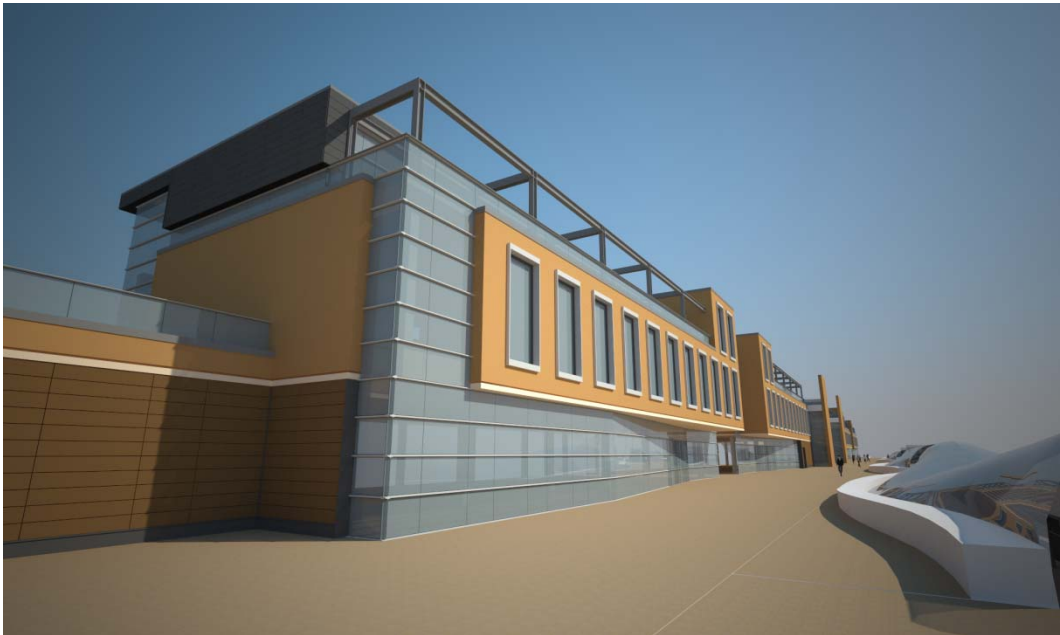

**Figure 145 - Station IJzijde: Proposal 9**



**Figure 146 - Station IJzijde: Proposal 9**

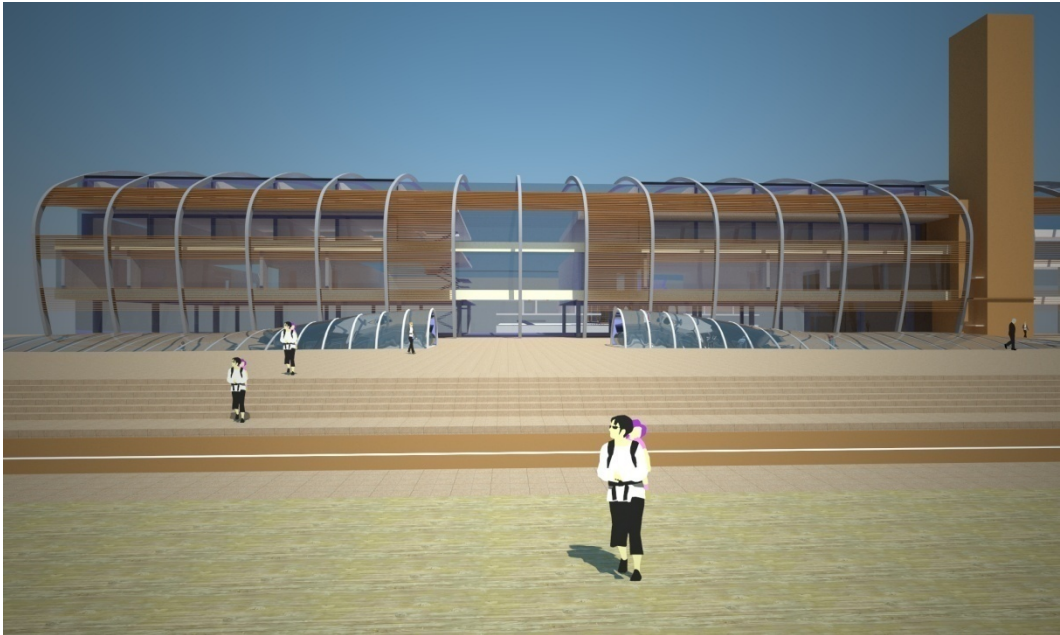

**Figure 147 - Station IJzijde: Final Proposal (Process)**

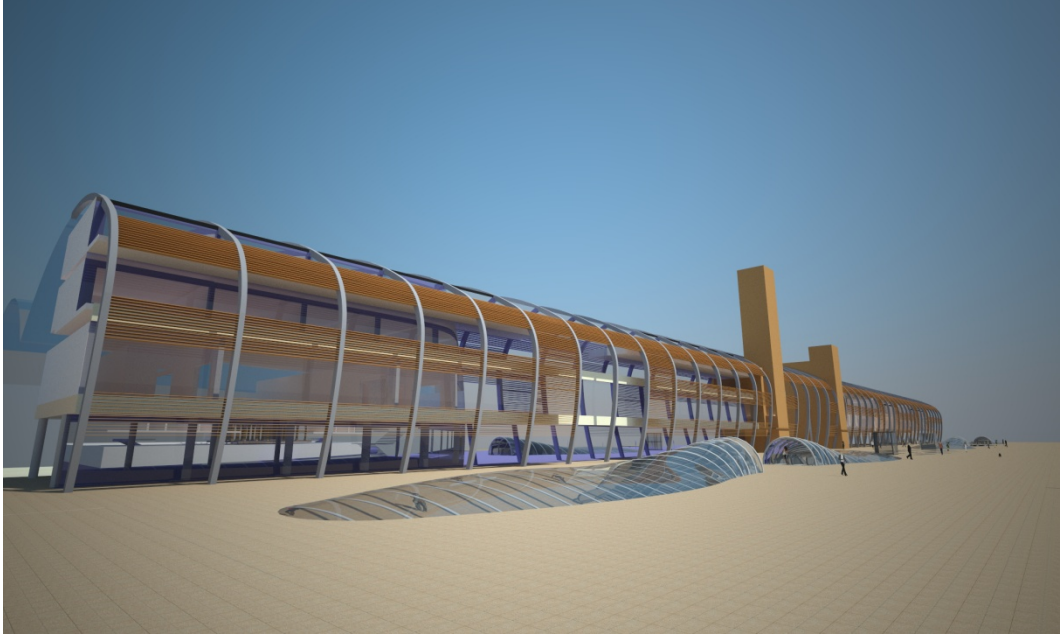

**Figure 148 - Station IJzijde: Final Proposal (Process)**



**Figure 149 - Station IJzijde: Final Proposal**

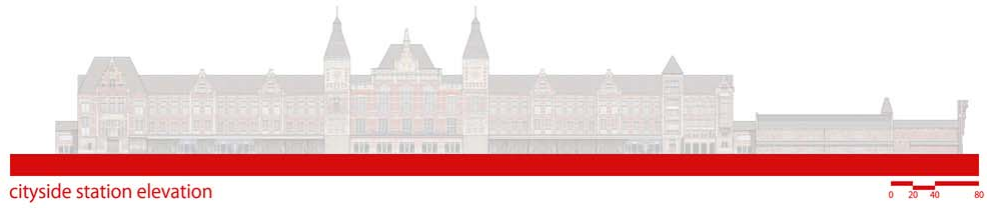

cityside station elevation



waterside station elevation

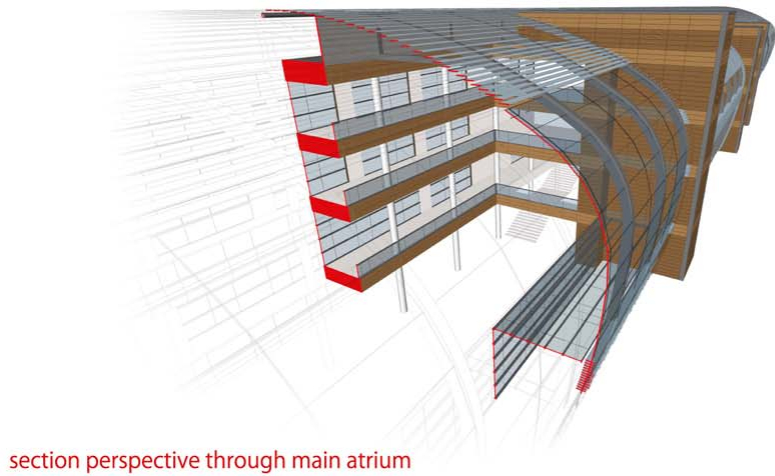

section perspective through main atrium

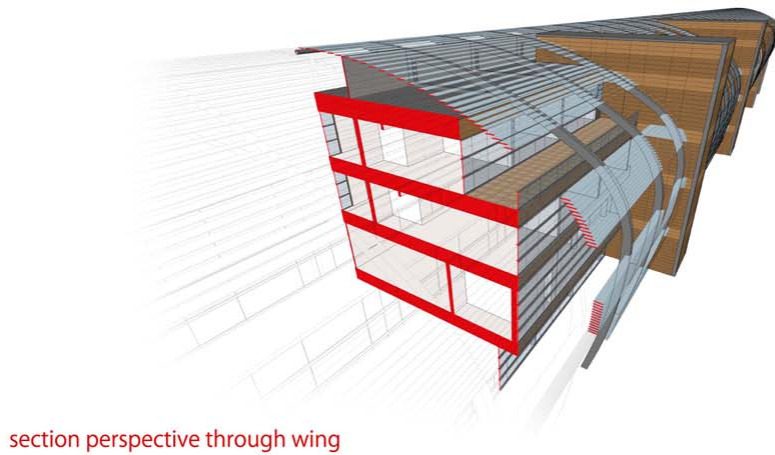

section perspective through wing

**Figure 150 - Station IJzijde: Sections and Elevations**

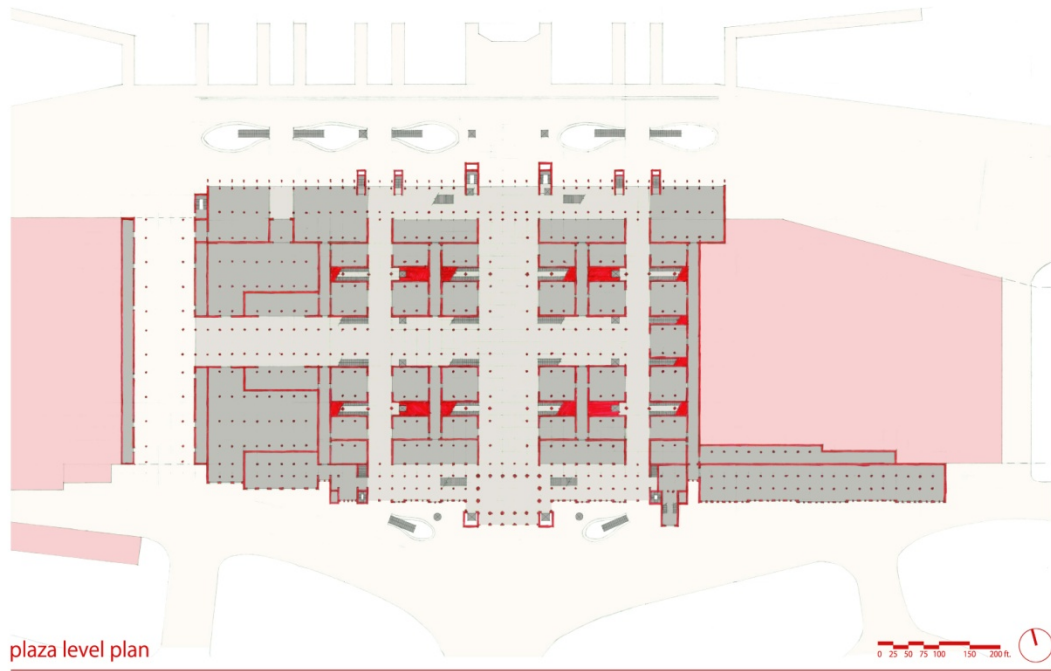

Figure 151 - Ground Floor Plan

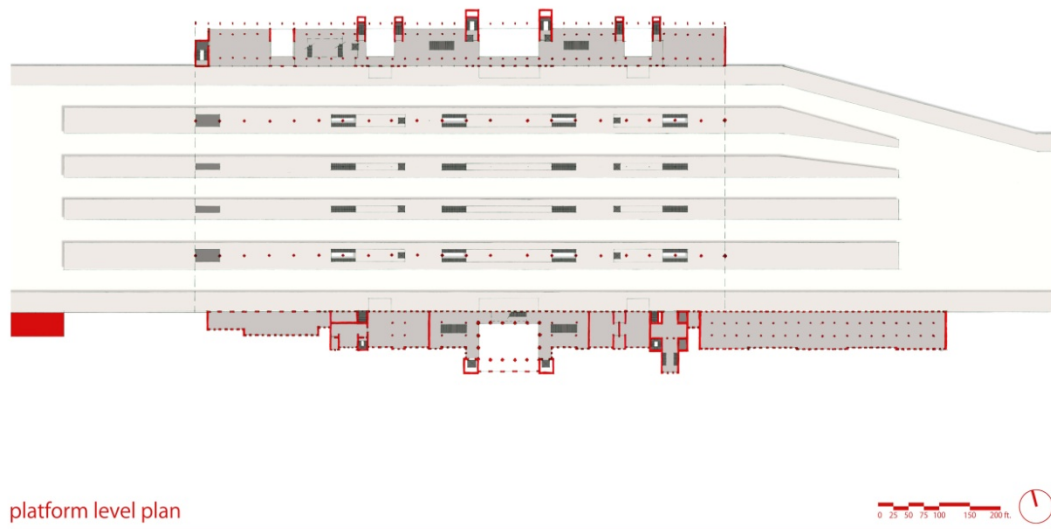
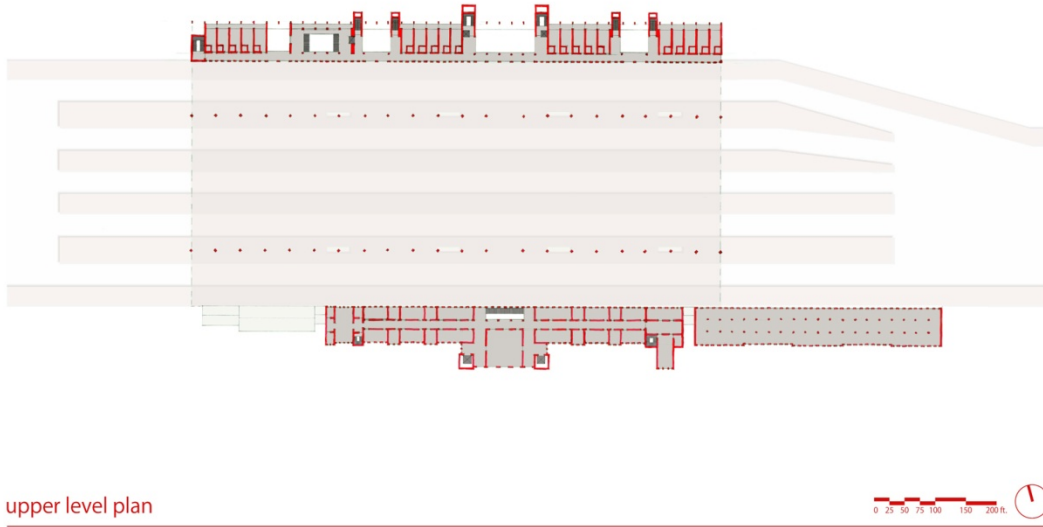

Figure 152 - First Floor Plan



**Figure 153 - Second Floor Plan**

## Before and After



Figure 154 - Before: Stationsplein



Figure 155 - After: Stationsplein



**Figure 156 - Before: Central Passage**



**Figure 157 - After: Central Passage**



Figure 158 - Before: Platform Area

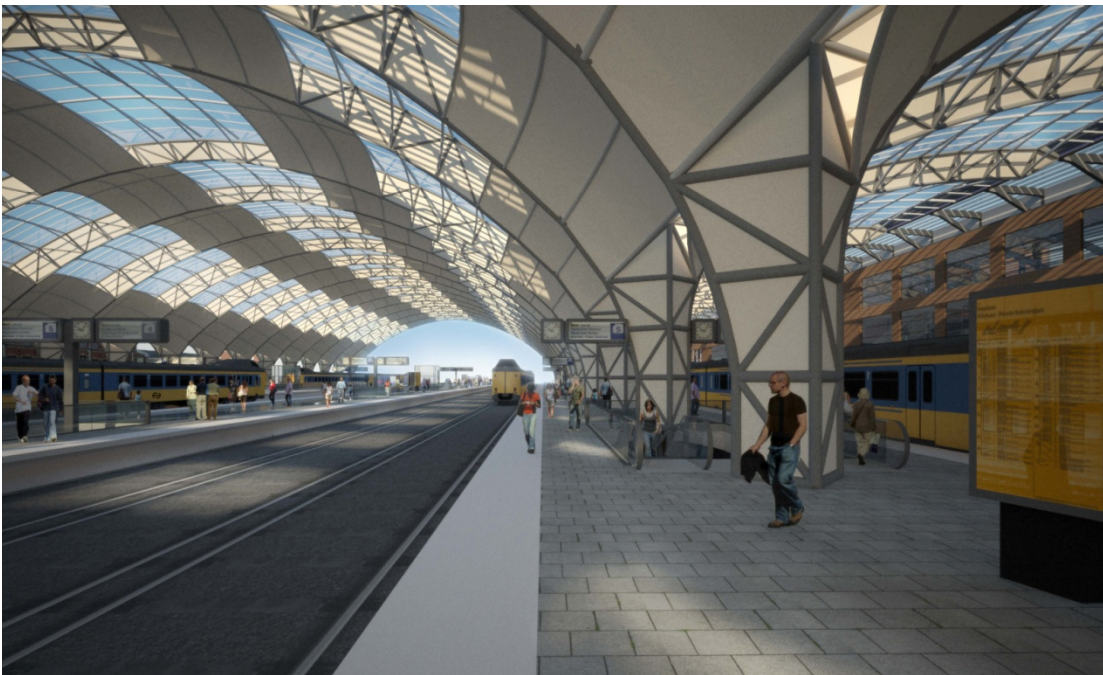

Figure 159 - After: Platform Area



Figure 160 - Before: Ruyterkade



Figure 161 - After: Ruyterplein



Figure 162 - Before: Metro Entrance



Figure 163 - After: Metro Entrance



Figure 164 - Before: Metro Station



Figure 165 - After: Transferium A



Figure 166 - Before: Bus Depot



Figure 167 - After: Transferium B



Figure 168 - Before: Bus Depot



Figure 169 - After: Transferium B Exit

## **Chapter 6: Conclusions**

### **A New Gateway**

This thesis has aimed to critically examine Amsterdam Centraal Station in its role as a gateway to the city of Amsterdam and as a multimodal transportation center. In doing so, it has operated at a variety of scales and levels, and has addressed a large scope of issues. In addition to solving the immediate practical problems of the intermodal transport functions, this thesis has also attempted to reintroduce the cultural and historical layers of the site that have remained hidden since the construction of the station in 1889.

By bringing the presence and path of the river back to active consciousness and emphasizing the direction of that path through the station and out to the water, one is able to observe a crucial layer of Amsterdam's history and to develop their understanding of the city. By providing a new destination at the water and by creating a major public space in the form of the Ruyterplein, the station can now serve to unite the surrounding docklands developments, giving them a center and knitting them together as a stronger urban condition. Finally, by reconfiguring the modes of transport, dealing with the functional issues of the site, and ultimately being able to clean up the Stationsplein, the view from the city to the station is improved significantly, allowing it to be the urban palace and gateway that it was intended to be.

The lessons learned in this thesis can be broadly applied to investigating many types of problems. In addition to the strategies developed to re-imagine the site as a true gateway, it also offers ideas about dealing with adaptive re-use, complex transportation issues, pedagogical program spaces, and linear parks as urban centers.

Although this thesis has come far in investigating, evaluating, and responding to the problems posed by the site and its requirements, there is much work that would have to be done to truly find any kind of conclusive solution. The conditions of the site are extremely difficult to work with, and while this thesis has proposed some successful ways of dealing with them, there remain many possibilities to be tested and evaluated.

What has become clear is that in order for the station to function as a true gateway to the city, it has to be architecturally, spatially, visually, and conceptually connected to the surrounding city. The resulting scope of the proposal is thus both large and thorough, but it is this level of intervention that is needed if the site is to realize its full potential. Amsterdam is and has always been a center of culture, learning, and trade, but if it is to continue to be so, it must also have an entry and gateway that is worthy of the character of the city itself.

*Ritsaart Jens Marcelis Schotanus, May 2009.*

## Additional Images

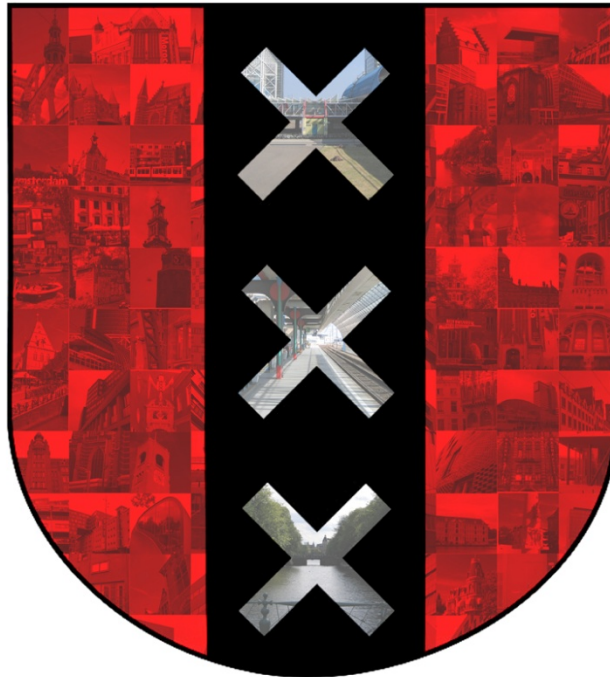
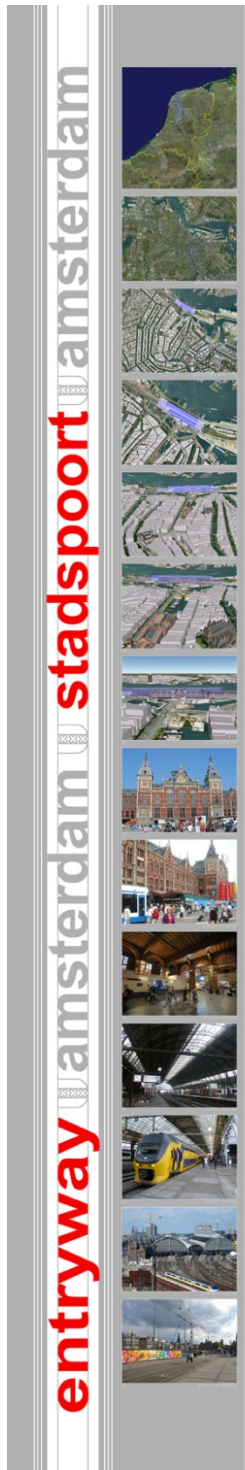

heldhaftig xxx vastberaden xxx barmhartig



Thesis: to create an entry to Amsterdam which both draws from and is evocative of the city's culture, history, and architecture.

Figure 170 - Thesis Match Poster



Figure 171 - Amsterdam Inner City Aerial Map (Image assembled by author from Google Earth)

# site information

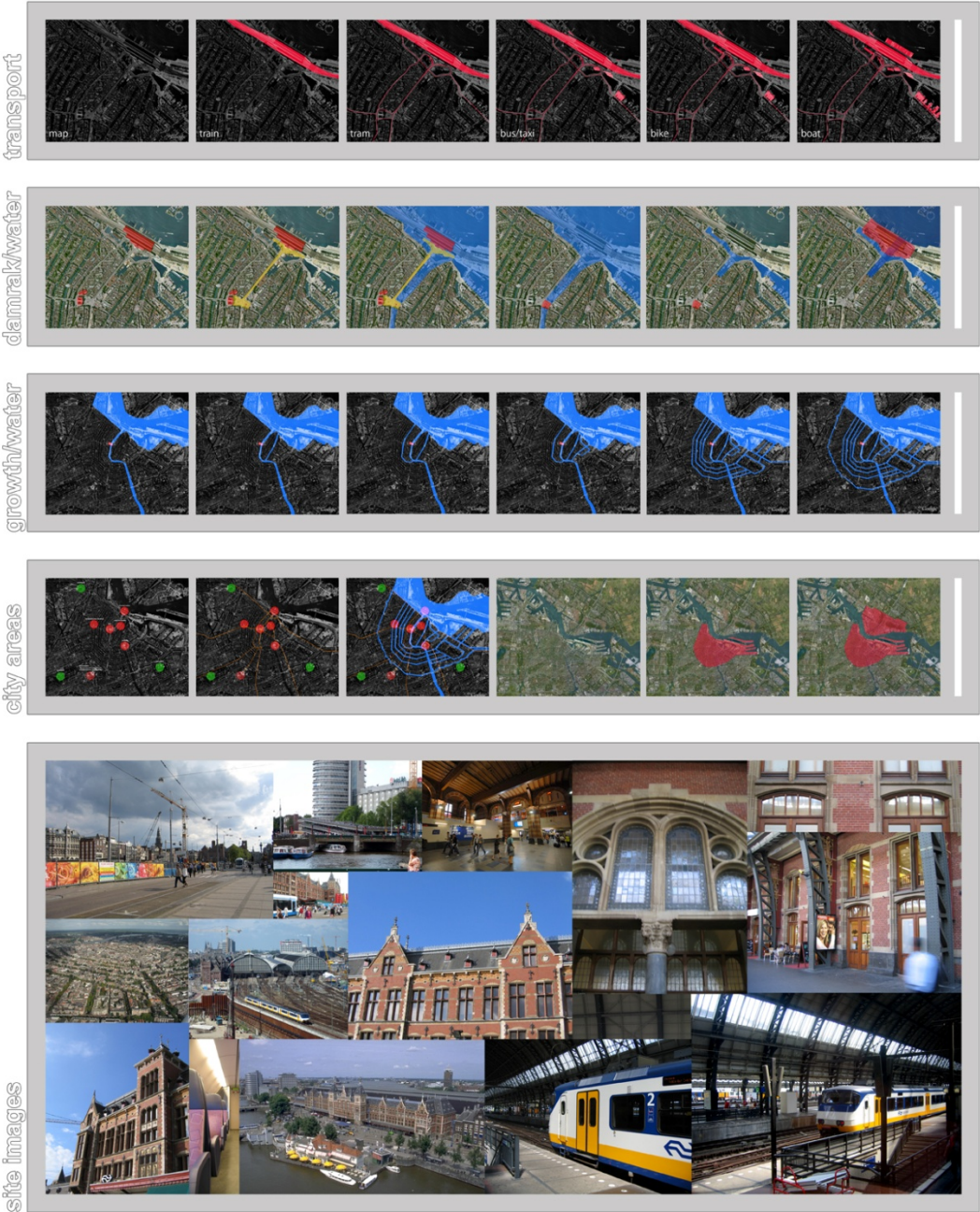

Figure 172 - Site Diagrams and Images

# other areas of investigation



Figure 173 - Investigations

# massing options



key	station image	option_00: description advantages/disadvantages	tram	bus	bike	taxi	water
scalpel		<b>option_01: cosmetic</b> +preserves entire station & all service buildings least expensive -least time consuming -no options for reconfiguring transport no possibility of visual connection to water intervention limited to cosmetic changes					
		<b>option_02: remove service</b> +preserves entire station & all historic spaces allows for reconfiguration of bicycle transport relatively inexpensive -options for reconfiguring transport very limited no possibility of visual connection to water need to relocate service functions					
wusthof		<b>option_03: passages</b> +preserves most of station & historic spaces allows for reconfiguration of bicycle transport allows for reconfiguration of pedestrian circulation -options for reconfiguring transport very limited visual connection to water is difficult to make need to relocate service functions					
		<b>option_04: three equal pavilions</b> +preserves pavilions & main gate allows for reconfiguration of all transport allows visual connection to water -some historic areas lost (first class lounge, etc.) need to relocate office functions					
machete		<b>option_05: main and flanking pavilions</b> +preserves pavilions, main gate, & waiting rooms allows for reconfiguration of bicycle transport allows visual connection to water -some historic areas lost reconfiguration of most transport is difficult need to relocate service & office functions					
		<b>option_06: three gates</b> +preserves pavilions & main gate allows for reconfiguration of all transport possibility for strong visual connection to water -many historic areas lost need to relocate office functions					
		<b>option_07: no main gate</b> +preserves pavilions & wings (most of historic station) allows for reconfiguration of bicycle transport possibility for visual connection to water main gate and towers are lost options for reconfiguring transport very limited need to relocate service functions					
		<b>option_08: central block (large)</b> +preserves main gate & wings (waiting areas) allows for reconfiguration of most transport some possibility for visual connection to water -pavilions are lost reconfiguring tram service is difficult need to relocate service functions					
sledgehammer		<b>option_09: central block (small)</b> +preserves main gate & first class lounge allows for reconfiguration of all transport strong possibility for visual connection to water -pavilions & most of wings are lost need to relocate office functions					
		<b>option_10: main gate only</b> +preserves main gate allows for reconfiguration of all transport strong possibility for visual connection to water -almost entire historic station must be removed need to relocate office functions					
		<b>option_11: complete renewal</b> +blank slate; able to redefine entry completely allows for reconfiguration of all transport strong possibility for visual connection to water -loss of entire historic station no memory of original station/entry image need to relocate all lost functions					
tmt							

Figure 174 - Massing Studies

# preservation?



cuyppers' restorations



**St. Servaas, Maastricht (NL)**  
 built 1000-1240, with various later additions  
 restored by Cuyppers 1866-1900  
 major changes by Cuyppers included:  
 - replacement of eastern gable at choir  
 - all towers were retrofitted with neo-gothic spires  
 - replacement of baroque tower at westwork with new design by Cuyppers (destroyed by fire in 1955, never rebuilt)  
 - removal of all baroque details  
 - neo-gothic interior (since removed)



**Dom, Mainz (D)**  
 begun 1100, most work completed by 1430  
 restored by Cuyppers 1872-1877  
 major changes by Cuyppers included:  
 - completion/redesign of original eastern flanking towers  
 - demolition of old crossing tower  
 - new crossing tower at choir (shown top right)  
 - removal of baroque additions and details  
 - neo-gothic interior



**Munsterkerk, Roermond (NL)**  
 built 1220-1260 as Cistercian abbey  
 restored by Cuyppers 1863-1890  
 major changes by Cuyppers included:  
 - replacement of original western towers  
 - addition of one level onto westwork  
 - replacement of tops of original towers at choir  
 - neo-gothic interior (since removed)

memories of the wall



montelbaanstoren



munttoren/regulierspoort



schreierstoren



sint antoniespoort/waag

reduce, reuse, recycle



adaptive reuse of church and monastery for hotel



adaptive reuse of church for bookstore



adaptive reuse of historic courtyard

Figure 175 - Preservation?



Figure 176 - Green Spaces, Views, and Scale Comparison of Iconic Buildings



aerial view of existing conditions

### existing site issues

- a. **bus areas at plaza**  
too many forms of transportation on plaza; location of bus depot is confusing and not well-integrated with passenger flow
- b. **bus depot**  
existing bus depot is poorly integrated with surrounding buildings; existing tourist-related buildings are obtrusive, blocking views out to the city and making way-finding difficult for visitors; buildings are kitschy in character and do not blend with their surroundings
- c. **station entry**  
existing entry is dark and low and facade does not convey sense of space; entry is poorly integrated with surrounding buildings
- d. **existing station buildings**  
existing station building wings block views out to harbor area; ways to address this must be investigated
- e. **bus depot**  
need for expansion of bus services has caused bus depots to be placed within city, causing inconvenience and confusion
- f. **bicycle parking**  
current bicycle storage areas are insufficient, causing overflow bicycle parking on bridges
- g. **train sheds**  
existing train sheds block light and could be refurbished/replaced
- h. **lack of waterside image**  
existing waterside only has highway and rear station exits; existing waterside image is not clear
- i. **taxi waiting area**  
current taxi drop-off/pick-up zone interferes with pedestrian circulation and is inadequately sized



aerial view of proposed scheme elements

### proposed scheme elements

- a. **existing station and plaza**  
restore interior of station building and clear plaza area of all traffic
- b. **new boat dock/tourist center**  
replace old tourist-related buildings with a less obtrusive structure which does not block views out to the city
- c. **new passageways**  
provide greater connectivity between station areas; provide retail spaces at existing building along corridors
- d. **new waterside station building**  
provide new waterside image of the station/city; retail/market space on ground floor, walking areas on first floor, offices above
- e. **podce space**  
retail areas, storage spaces for retail and service, bathrooms, other service functions, vertical circulation
- f. **bus depot**  
consolidated bus depot under tracks; buses enter from city side and depart at water side to join ring highway
- g. **taxi and bike area**  
drop-off/pick-up area for taxis and secured bicycle storage areas for commuters and visitors
- h. **new ferry pier & building**  
new ferry pier and building serving North Amsterdam; provide new ticketing building/waiting room at pier
- i. **new waterfront promenade**  
new pedestrian-oriented area at waterfront to provide a water-side city image and to link with adjacent developments to west and east
- j. **art space**  
exhibition space, possibly related to Muziegebouw



existing interior perspective of entry hall



existing interior perspective of main passage



interior perspective of entry hall w/ daylight beyond

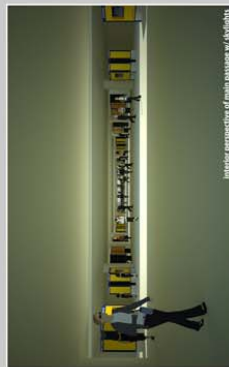

interior perspective of main passage w/ daylight

Figure 177 - Schematic Images

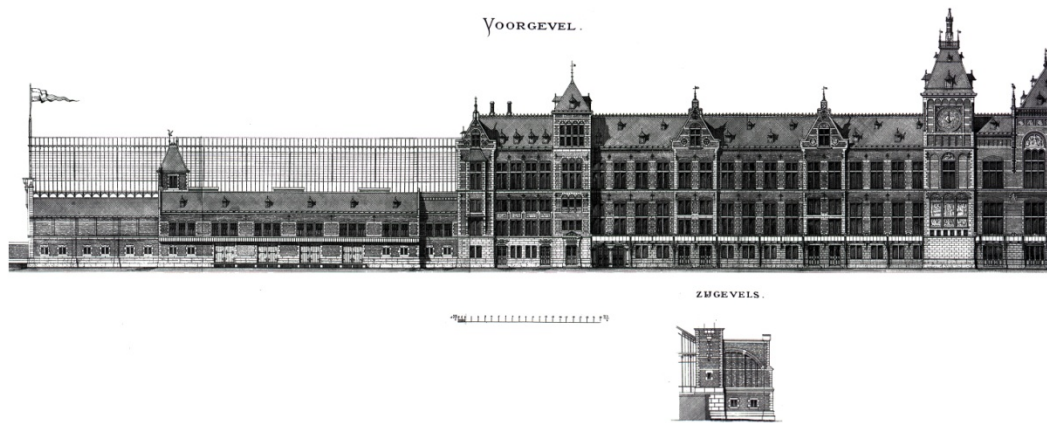

Figure 178 - Original Station Elevation, West Side. Scan courtesy of City Archives of Amsterdam.



Figure 179 - Original Station Elevation East Side. Scan courtesy of City Archives of Amsterdam.

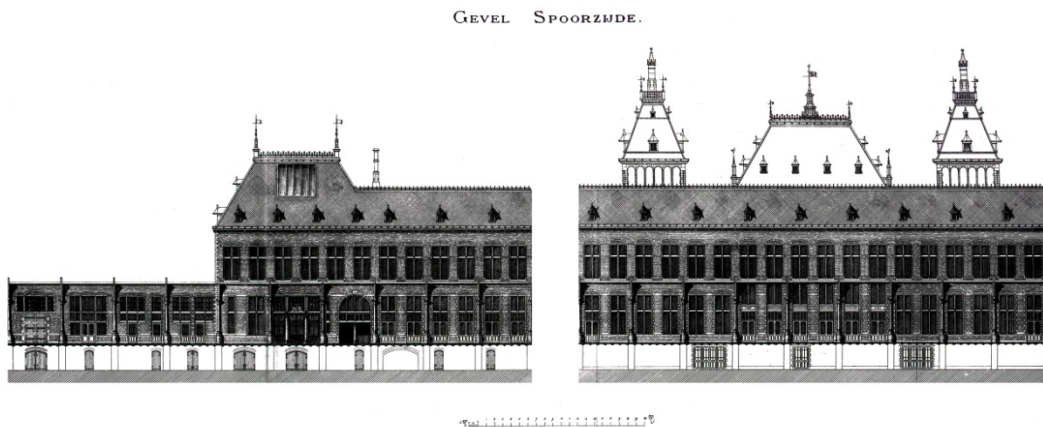

Figure 180 - Original Station Rear Elevation. Scan courtesy of City Archives of Amsterdam.

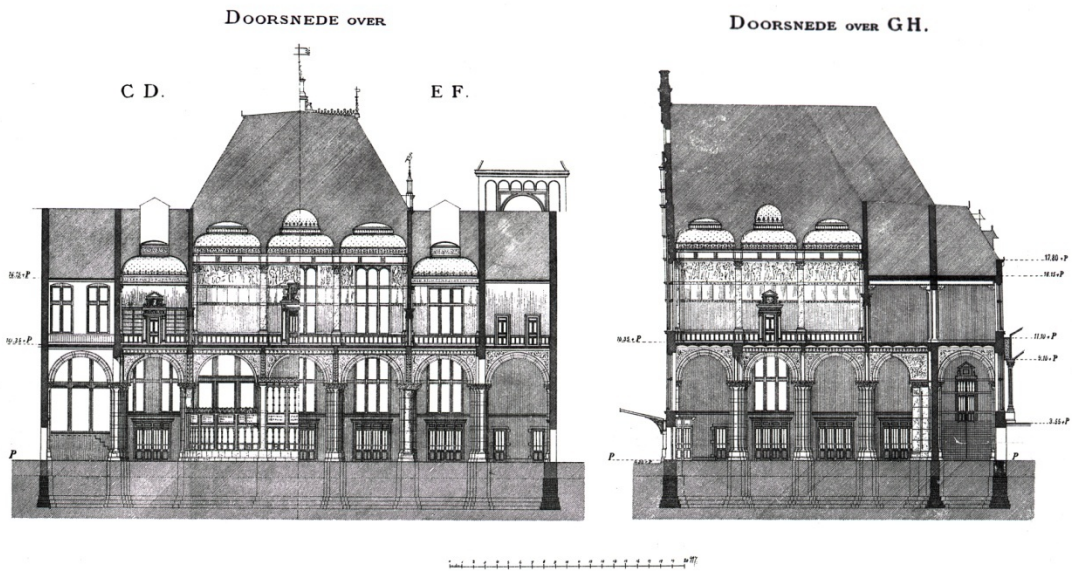

Figure 181 - Section Through Main Hall. Scan courtesy of City Archives of Amsterdam.

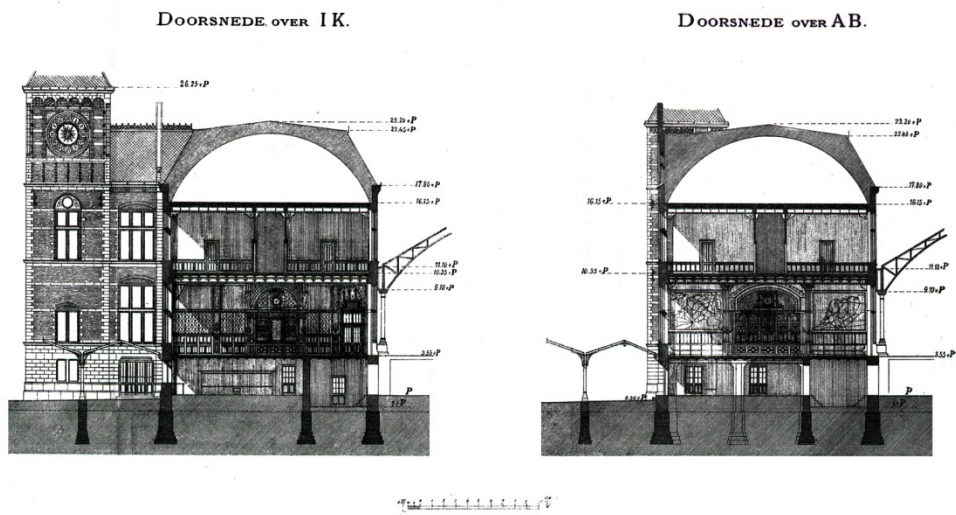

Figure 182 - Section Through Wings. Scan courtesy of City Archives of Amsterdam.

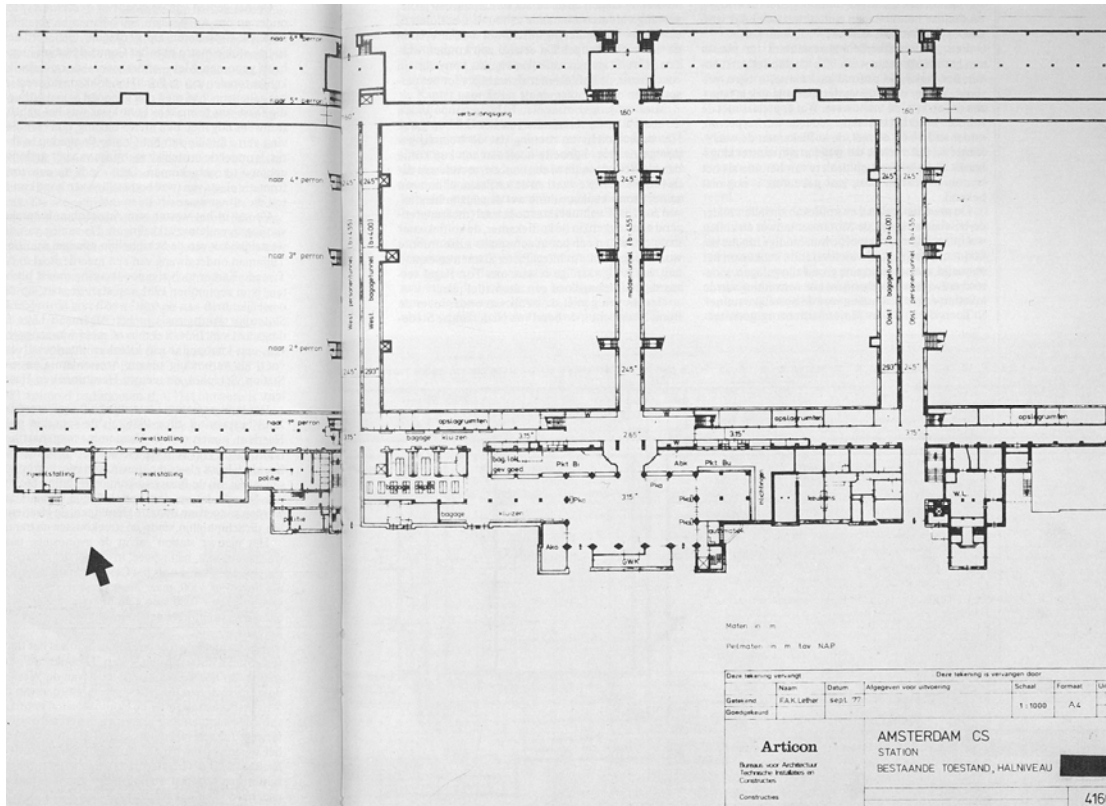

Figure 183 - Original Station Ground Floor Plan. (Scanned from Lansink, Lydia. Geschiedenis van het Amsterdamse Stationsplein.)

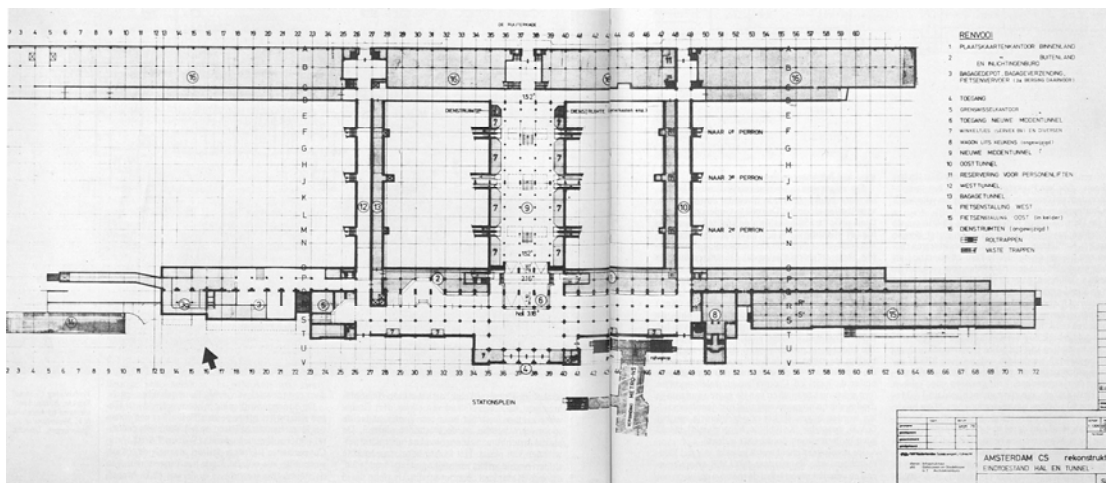

Figure 184 - Renovated Station Ground Floor Plan in 1980. (Scanned from Lansink, Lydia. Geschiedenis van het Amsterdamse Stationsplein.)

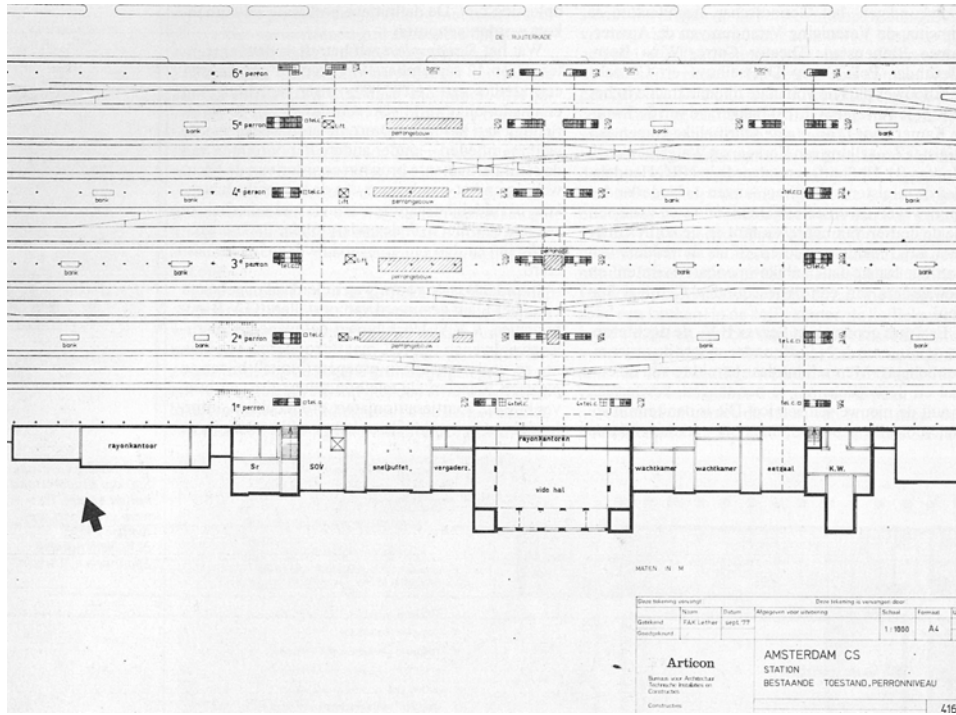

Figure 185 - Original Station First Floor Plan. (Scanned from Lansink, Lydia. Geschiedenis van het Amsterdamse Stationsplein.)

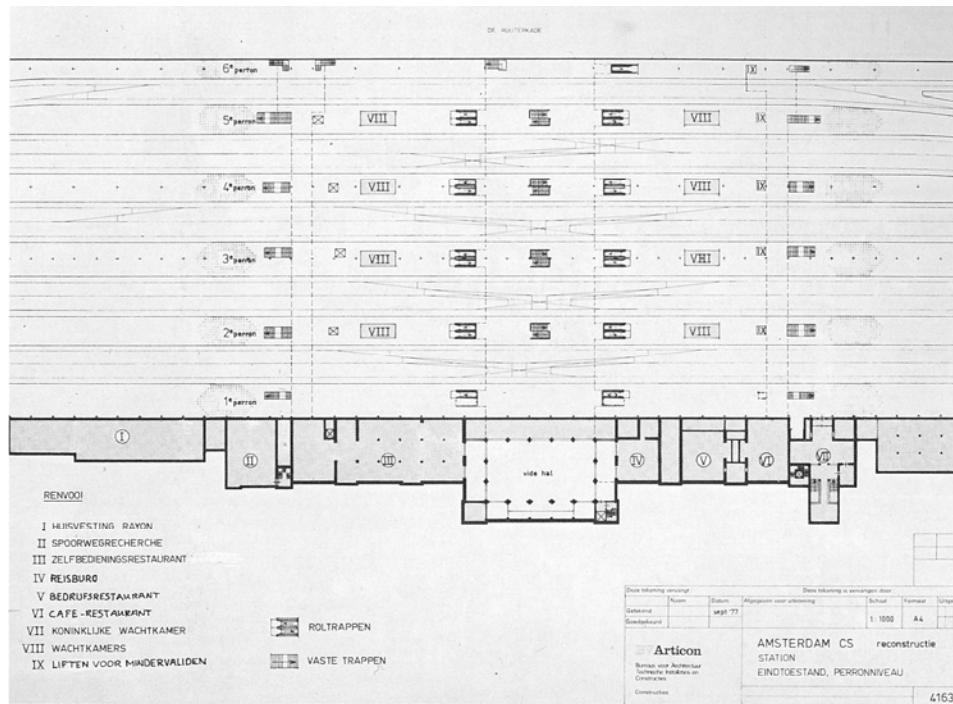

Figure 186 - Renovated Station First Floor Plan in 1980. (Scanned from Lansink, Lydia. Geschiedenis van het Amsterdamse Stationsplein.)

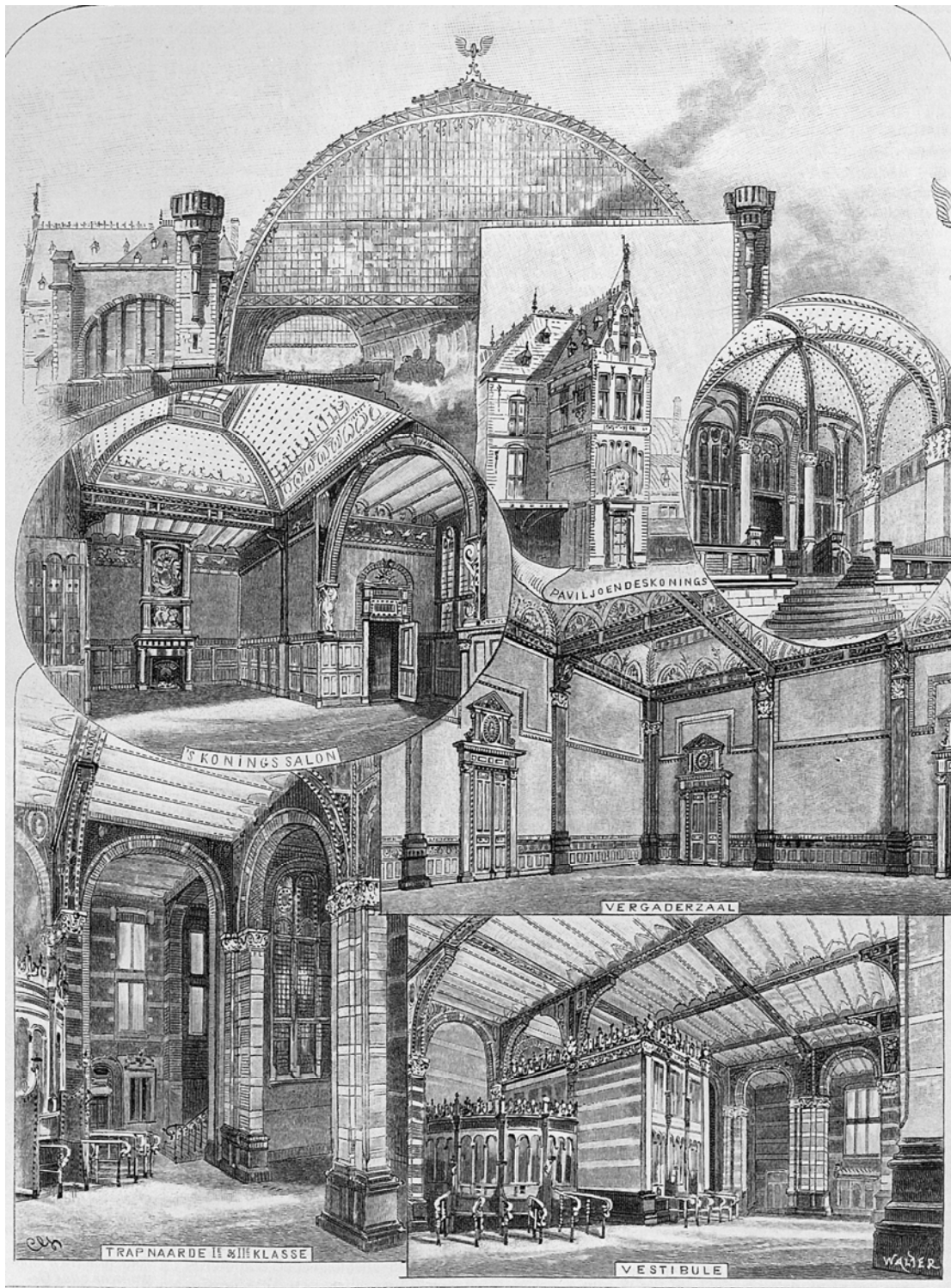

Figure 187 - Etchings of Original Station Interiors (Scanned from Dal, Johan W. van. Architectuur Langs de Rails.)

## Bibliography

- Abrahamse, Jaap Evert. Eastern Harbour District Amsterdam: Urbanism and Architecture. NAI Publishers, Rotterdam 2006.
- Berens, Hetty. PJH Cuypers: The Complete Works. NAI Publishers, Rotterdam 2007.
- Binney, Marcus. Architecture of Rail. Academy Editions, London 1995.
- Breithack, Matthias. Amsterdam Architecture and Design. TeNeues Verlag, Kempen 2004.
- Dal, Johan W. van. Architectuur Langs de Rails. Kluwer Technische Boeken, Deventer 1981.
- Gerkan, Meinhard von. Von Gerkan, Marg, und Partner = Architecture for Transportation. Birkhäuser, Boston 1997.
- Geuze, Adriaan. Residential Waterfront: Borneo Sporenburg. Harvard University Graduate School of Design, Cambridge 2005.
- Kemme, Guus and Bekkers, Gaston. Amsterdam Architecture. Thoth Publishers, Bussum 2006.
- Kloos, Maarten, ed. Amsterdam: An Architectural Lesson. Thoth Publishers, Amsterdam 1988.

Kruizinga, J. H. Watergraafsmeer. C. V. Allert de Lange, Amsterdam 1948.

Lansink, Lydia. Geschiedenis van het Amsterdamse Stationsplein. Raad voor de Stedebouw, Amsterdam 1982.

Marijs, Meindert H. M. Amsterdam in Beeld. Omniboek, Den Haag 1983.

Ravesteyn, Simon van. Nederlandse Architectuur. Stichting Architectuurmuseum, Amsterdam 1978.

Ufford, C. C. G. Quarles van. Amsterdam Voor't Eerst Gefotografeerd. J. H. de Bussy, Amsterdam 1972.

Wattjes, J. G. and Warners, F. A. Amsterdamse Bouwkunst en Stadsschoon. C. V. Allert de Lange, Amsterdam 1944.

Westrum, L. C. Schade van. Amsterdam per Vigilante. Pictura, Utrecht 1966.