

ABSTRACT

Title of Dissertation: MIDDLE SCHOOL STUDENTS' LEARNING AND
MOTIVATION IN PHYSICAL EDUCATION: A SELF-
DETERMINATION PERSPECTIVE

Haichun Sun, Doctor of Philosophy, 2007

Directed By: Associate Professor, Ang Chen
Department of Kinesiology

Self-determination theory (SDT) explains human motivation by focusing on the importance of motivational regulation based on three basic needs: the needs for competence, autonomy, and relatedness. SDT, when applied in education, emphasizes helping learners internalize extrinsic motivation so as to regulate their learning behavior from an amotivation state to intrinsic motivation. Guided by self-determination theory, the dissertation study was designed for two major purposes: (a) examining the inter-relationships of the components in the self-regulation model to verify its tenability in motivating middle school learners in physical education, and (b) identifying the contribution of the self-regulated motivations to knowledge and skill learning in physical education. Two separate studies were conducted to answer the research questions. In Study 1, 297 sixth grade students from 15 randomly selected middle schools provided need satisfaction and self-regulated motivation data for a two-step structural equation modeling analysis. The results indicated that students' satisfaction of autonomy and competence accounted for a large portion of variability in intrinsic motivation and in identified regulation. Satisfaction of autonomy also contributed to introjected regulation. Satisfaction of any of the needs did not contribute to the external regulation. It was also

found that individuals who exhibited satisfaction in competence need lessened amotivation. Unexpectedly, it was found that satisfying the need for relatedness is likely to lead students to becoming amotivated in physical education. In Study 2, 242 participants provided data on SDT components and their learning on health related fitness knowledge and two motor skills determined using a pre- and post-assessment research design. Descriptive statistics showed that students were motivated but learned little. Subsequent structural equation modeling analyses revealed that extrinsic motivation and intrinsic motivation did not contribute to knowledge and skill achievement and amotivation impeded knowledge learning. The findings imply that when competence-based learning achievement is absent, learners can be motivated but do not achieve what they are expected to achieve. The findings provide theoretical insights to developing a constructivist learning environment to direct students' motivation toward learning in physical education and strongly suggest that a curriculum reform in physical education is needed to strengthen competence-based learning (knowledge and skill growth).

MIDDLE SCHOOL STUDENTS' LEARNING AND MOTIVATION
IN PHYSICAL EDUCATION: A SELF-DETERMINATION PERSPECTIVE

By

Haichun Sun

Dissertation submitted to the Faculty of the Graduate School of the
University of Maryland, College Park, in partial fulfillment
of the requirements for the degree of
Doctor of Philosophy
2007

Advisory Committee:

Associate Professor Ang Chen, Chair
Professor Patricia A. Alexander
Professor Catherine D. Ennis
Dr. Colleen M. Farmer
Professor Bradley D. Hatfield

© Copyright by
[Haichun Sun]
[2007]

Acknowledgements

I wish to express a sincere gratitude to all those who have helped me with this dissertation and throughout my education at University of Maryland.

I would first like to gratefully and sincerely thank my advisor, Dr. Ang Chen. I have been amazingly fortunate to have an advisor who is so patient, supportive, and always there to listen and give advice. Without his help, I would not have finished this dissertation.

I am deeply grateful and thankful to Dr. Catherine D. Ennis for everything she has done for me during the last four years. I am also thankful to her for reading my dissertation, commenting on my views, and helping me to use correct grammar and consistent notation in my writings.

I would also like to thank my other three committee members, Dr. Bradley D. Hatfield, Dr. Colleen M. Farmer, and Dr. Patricia A. Alexander, for their guidance and helpful suggestions with this dissertation.

Additionally, I am very grateful for the friendship of all of the members in the Curriculum & Instruction research lab, Christine, Marina, Mihae, and Xihe, for providing me a caring and motivating environment for study and research.

Finally, and most importantly, I would like to thank my husband, Lei Cheng, my parents, Ruliang Sun, Qikun Yao, and my brother, Hailin Sun, for their love and support. Without their encouragement, I could not have completed my Ph.D program.

Table of Contents

Acknowledgements.....	II
Table of Contents.....	III
List of Tables.....	IV
List of Figures.....	V
Study 1: Need Satisfaction and Self-regulated Motivation.....	1
Introduction.....	1
Method.....	7
Results.....	12
Discussion.....	14
Study 2: Self-regulated Motivation and Learning.....	33
Introduction.....	33
Method.....	40
Results.....	48
Discussion.....	51
Conclusions and Recommendation.....	70
Appendix A: Overall Introduction.....	75
APPENDIX B: Extended Review of Literature.....	100
APPENDIX C: Methodology.....	173
APPENDIX D: Hypothesized Model of Study.....	194
APPENDIX E: Six Grade Knowledge Test.....	196
APPENDIX F: Survey of Need Satisfaction and Self-regulation.....	199
Bibliography.....	204

List of Tables

1. Means, Standard Deviations, and Cronbach's Alphas for All Subscales in Study 1	29
2. Factors Loadings in the Measurement Models in Study 1	30
3. Standardized Parameter Estimates in Study 1	31
4. Means, Standard Deviations, and Cronbach's Alphas for All Subscales in Study 2	64
5. Results of Paired t-test in Study 2	65
6. Correlations among Self-determined Regulations in Study 2	66

List of Figures

1. The Hypothesized Structural Model of Study 1	33
2. Hypothesized Model Examined in SEM in Study 1	34
3. The Hypothesized Model of Study 2	68
4. Lockhart-McPherson Badminton Test Setup	69
5. Court markings for the AAHPERD Basketball Control Dribble Test	70
6. SEM Results for Hypothesized Paths in Study 2	71

Need Satisfaction and Self-regulated Motivation: An Examination of Self-Determination Theory in Sixth Grade Physical Education Students

Research on motivation in education has identified and delineated in detail the characteristics of motivation sources. These sources include students' achievement goal orientations (Nicholls, 1984), beliefs of success and conception of task values (Eccles et al., 1983), and interest in the content (Renninger, Hidi, & Krapp, 1992). Through the studies on various motivational constructs, we have gained knowledge about the origins of student achievement motivation. In addition to the goals, interest, and values, Pintrich (2003) argued that we need to identify the basic needs that define what individuals want to further our understanding of students' motivation. Based on an integrated approach to studying the simultaneous relationship of basic human needs and social-cognitive influences, the self-determination theory (SDT) (Deci & Ryan, 1985; Ryan & Deci, 2000a) is structured uniquely to allow empirical examinations of the relationship between human innate needs and motivation. The purpose of this study was to explore the relationship between students' basic needs and their motivation orientations in middle school physical education.

The Basic Innate Needs

According to Deci and Ryan (1985, 2000), human needs specify motivation and provide a fundamental basis that energizes and directs behaviors in an environment, such as a classroom, a gymnasium, or a playground. In SDT, human needs refer to "innate psychological nutrients that are essential for ongoing psychological growth, integrity, and well-being" (Deci & Ryan, 2000, p. 229). Specifically, the needs for competence, autonomy, and relatedness are considered as the cornerstones of human motivation.

In SDT, *Competence* refers to the satisfaction for ones' ability and feelings of being effective in an activity (Deci & Ryan, 1985). The more competent a person perceives him/herself in an activity; the more intrinsically motivated one will be for that activity (Deci & Ryan, 1985). *Autonomy* is the degree to which an individual perceives her/himself as the origin or source of a behavior and as being responsible for the initiation of the behavior (Ryan & Deci, 2000a). When experiencing autonomy, an individual regulates his/her own behavior by governing the initiation and direction of actions (Ryan & Powlson, 1991). *Relatedness* is defined as the extent to which an individual feels connected to others and their senses of belonging both with one's community and with other individuals (Ryan & Deci, 2000a).

Intrinsic Motivation, Extrinsic Motivation, and Amotivation

Deci and Ryan (1985; 2000) conceptualized self-determination as a motivational process in which an individual self-regulates his/her action depending on the degree of his/her needs satisfaction. Thus, motivation can be understood in three basic states, intrinsic motivation, extrinsic motivation, and amotivation. *Intrinsic motivation* is manifested through individuals' engagement in an activity for the sake of the activity itself and for the satisfaction inherent in performing the activity (Deci & Ryan, 1985). Intrinsic motivation often derives from person-activity interaction in activities that people find interesting, optimal challenging, or aesthetically pleasing (Ryan & Deci, 2000b).

Extrinsic motivation, in contrast to intrinsic motivation, specifies situations in which individuals engage in an activity in order to obtain certain desirable and separate outcomes. Extrinsically motivated behaviors do not occur spontaneously out of the characteristics of a task or activity and these behaviors require the provision of external

factors if they have to occur (Deci & Ryan, 1985). These external factors, such as rewards, grades, praise, or punishment, function to impose an externally controlled regulation to the individual to bring about and reinforce the desired behavior. The regulation processes include: *External regulation*, *Introjected regulation*, *Identified regulation*, and *Integrated regulation* (e.g., Deci & Ryan, 1985).

External regulation occurs when one is anticipating a certain outcome associated with the required behaviors. For example, a student may participate in a running program because he/she will be rewarded for participation (e.g., a T-shirt or hat), despite that the student does not like running. In this case, the behavior (participation) is regulated through extrinsic rewards and may be sustained through the student's anticipation to receive a reward. The running behavior, thus, is self-regulated by the externally imposed consequence that is anticipated (Deci & Ryan, 1985).

Introjected regulation refers to an individual's partial or suboptimal internalization of the extrinsic value or regulatory process, but the external value has not accepted it as his/her own. (Deci, Eghrari, Patrick, & Leone, 1994). An individual self-regulates his/her own behavior to comply with an expectation of having to rather than wanting to (Deci & Ryan, 1985). The introjected regulation is considered present in behaviors conducted in order to avoid a sense of guilt or to attain and maintain ego enhancement such as pride (Deci & Ryan, 1985).

Identified regulation is a form of extrinsic motivation with more internalized external values. An individual with identified regulation demonstrates more self-determination as he/she has accepted the form of regulation as his/her own through identifying self with the regulation process. For example, a student participates in running

because he/she identifies participation in running as part of him/herself in seeking optimal health.

Integrated regulation is the most self-determined form of extrinsic motivation. The individual integrates the external values into his/her own value system (Deci & Ryan, 1985). Individuals with integrated regulation not only do what they are required to do, but also display appreciation for the external values. Take running for instance again, students with integrated regulation believe that running is part of their life and are likely to run outside physical education to receive health benefits. It is worth noting that integrated regulation shares many qualities with intrinsic motivation, but it is still considered extrinsic because the purpose of the motivated behavior is to attain separable outcomes independent from the activity (such as good health, rather than interest or enjoyment of running, if referring to the running example).

Amotivation refers to situations where an individual lacks the intention to act (Ryan & Deci, 2000a). Amotivation occurs when an individual feels incompetent or helpless to do an activity, does not value the activity or not expect the activity to yield a desired outcome, or feels lack of control in an environment (Deci & Ryan, 1985; Ryan & Deci, 2000a). When an individual is amotivated, he/she either does not take part in the activity at all or just goes through the motions without intent (Ryan & Deci, 2000a). Research in physical education settings has revealed that amotivation leads to maladaptive consequences, such as boredom (Ntoumanis, 2001) or lack of intention to participate in after-school physical activities (Standage, Duda, & Ntoumanis, 2003).

Needs and Regulatory Process in Physical Education

SDT holds the assumption that the degree to which people experience need satisfaction in a context will influence their motivation in that environment (Deci & Ryan, 2000). In physical education, when the three needs are considered as one construct, the total need satisfaction was found positively predictive of students' intrinsic motivation and introjected motivation (Ntoumanis, 2005; Standage, Duda, & Ntoumanis, 2005). It can be reasoned, then, that an environment supporting students' overall innate need helps develop self-determined motivation. In a learning setting where the teacher dictates all learning decisions by limiting student choices, students are likely to yield to the imposed external regulation or to sink or fall into the state of amotivation (Standage, Duda, & Ntoumanis, 2005).

Although research has revealed that an overall need satisfaction can lead to more self-determined motivation, it is still not clear, due to inconsistent findings, about the contribution of satisfying each individual innate need to students' motivation in physical education. For example, students' autonomy need satisfaction was reported to predict students' intrinsic motivation and identified regulation in physical education in some studies (Hagger, Chatzisarantis, Barkoukis, & Wang, 2005; Hagger, Chatzisarantis, Culverhouse, & Biddle, 2003). However, other studies reported that autonomy need satisfaction had little contribution to any types of motivation (Ntoumanis, 2001). Similar inconsistency can be found in results about competence need satisfaction. For instance, the predicted relationships between competence need satisfaction and identified regulation and introjected regulation have been observed as positive in one study (Ntoumanis, 2001) but non-existent in another (Standage et al., 2003). The need for relatedness, a variable reflecting the degree of social interaction in learning, has been

reported to be a weak, though positive, predictor for intrinsic motivation, identified regulation, and introjected regulation (Ntoumanis, 2001; Standage et al., 2003).

Moreover, the inconsistency can become even more complicated when the functional inter-relationship among the need satisfactions is taken into account. For example, Gouda and Biddle (1994) reported that competence need satisfaction is related to intrinsic motivation only when the context is supportive for autonomy. They speculated that autonomy need satisfaction might be a more critical factor for intrinsic motivation than the competence need satisfaction is. Thus, individuals may not be intrinsically motivated in a context controlled by others such as teachers, no matter how competent they perceive they are.

Deci and Ryan (2000) argued that “each of these three needs plays a necessary part in optimal development so that none can be thwarted or neglected without significant negative consequences” (p. 229). From a pedagogical perspective, satisfaction of needs for autonomy, competence, and relatedness should enhance learner motivation and lead to greater learning. The uncertainty of their motivation function in physical education noted above limits the development of a motivating curriculum through providing a holistic framework in which each need can make unique contribution to learner motivation and learning. It is important, then, to clarify the individual contribution of satisfying each innate need for teachers to create a learning environment conducive to optimal learner motivation and achievement. Therein, this study aimed to answer the following question: to what extent does students’ satisfaction of the innate needs for autonomy, competence, and relatedness contribute to their self-regulated motivation? As specified in Figure 1, we hypothesized that students’ satisfaction of the innate needs for

autonomy, competence, and relatedness will contribute to students' intrinsic motivation, identified regulation, and introjected regulation and lessen external regulation and amotivation.

Method

Setting and Participants

The study was conducted as part of a larger curriculum field test research involving 15 middle schools. The schools and classes were randomly selected, with stratifications on students' socio-economic background and school size, from a large school district in a very large metropolitan area in the U. S. In the year of the study, the school district served 137,798 students. Among them 59% were ethnic minorities, including 22.9% African Americans, 0.3% Native American, 14.8% Asian Americans, 41.3% European Americans, and 20.7% Hispanic Americans; and 39% received meal assistance (National Center for Education Statistics [NCES], 2006).

The school district offers 180 minutes physical education per week to middle school students. Students are required to take physical education in three of the four academic quarters each year, with the remaining quarter dedicated to health education. All middle schools are equipped with at least one large gymnasium and adequate outside field space for current curriculum offerings. The middle school physical education curriculum focuses on educating students to become skillful, fit, and personally and socially responsible movers. On average, each school has three to five physical education teachers. Physical education is taught in typical multi-activity, sport based lessons. These lessons usually start with warm-up activities. After warm up, teachers often introduce and explain skills to the whole class and ask a few questions to check for understanding.

Students are encouraged to discuss and ask questions regarding what they are learning. More skilled students are always asked to demonstrate the skills to be learned and help the low skilled students during practice. When students practice the skills, they are grouped according to various criteria, such as gender or skill levels. Students sometimes are allowed to choose their own groups. Teachers observe students' practice and give individual students specific feedback. They often gather the whole class together to emphasize important aspects of a skill or correct common mistakes. Generally, teachers' instructional time allocation in physical education class includes: 13% class management, 9% warm up/cool down, 7% instruction, 3% cognitive task, 14% fitness, 24% skill practice, 25% sport games, and 6% off task (Chen & Ennis, 2007).

Participants were 6th grade students (n=344) whose intact classes were randomly chosen to provide data for the larger study. The final sample included 297 students who completed all data collection instruments. In the sample, there were 22 % African American, 0.3% Native American, 18.2% Asian American, 44.8% European American, and 18.2% Hispanic American. Parental consent was received prior to data collection.

Sixth graders were chosen in this study because they were in the transition from elementary to middle. Students at this stage were experiencing a different physical education curriculum from what they had in elementary school. A new physical education environment with changed learning goals and content would present a context in which students may have new experiences with respect to their need satisfaction and motivation. Another reason to choose sixth grade students is that this study is a part of the dissertation study and student knowledge and motor skill learning was measured in the second part of the larger study. By choosing sixth graders, the knowledge and skill

growth measured in the study can be largely attributed to the middle school curriculum. In other words, the internal validity for the measure of learning outcome might be better preserved.

Variables and Measures

In order to answer the research questions, the following variables were measured: (a) learner need satisfaction, and (b) types of self-regulated motivation. Consistent with research in education and physical education, students' needs satisfaction was measured on their perceptions of autonomy, competence, and relatedness in their classes. Types of self-determined motivation included amotivation, external regulation, introjected regulation, identified regulation, and intrinsic motivation. Identified regulation was not included in this study because the integration is not likely to be achieved among students at this young age (Ryan & Connell, 1989).

Need Satisfaction

To measure students' perceived satisfaction of the three innate needs, we used the previously validated instrument (Standage et al., 2003, 2005). The instrument includes three subscales with a total of 15 items. Each subscale consists of five items. Students respond to a 7-point Likert scale ranging from 1 (strongly disagree) and 7 (strongly agree). Previous research has reported that each subscale measure has Cronbach's alphas above .80 (Standage et al., 2003; Standage et al., 2005).

Self-Regulated Motivation

The different types of self-regulated motivation were measured using a questionnaire that Goudas and Biddle (1994) adapted from the original Self-Regulation Questionnaire (SRQ) created by Ryan and Connell (1989). The adapted questionnaire

includes five four-item subscales that measure intrinsic motivation, identified regulation, introjected regulation, external regulation, and amotivation. In various validations involving factor-analytical procedures for construct validity, the modified SRQ has shown distinct factor structures and good internal reliability (Cronbach $\alpha > .80$); except that the introjected regulation subscale has shown a weaker but still acceptable internal reliability ($.60 < \alpha < .70$) in some subsequent studies (e.g., Ntoumanis, 2001, 2005). The items are attached to a 7-point Likert type scales with Strongly Disagree as 1 and Strongly Agree as 7. Each item begins with a common stem “I take part in PE...” followed by the statement for rating such as “because PE is exciting” (intrinsic motivation), “because I want to learn sport skills” (identified regulation), “because I would feel bad about myself if I did not” (introjected regulation), “because I will get into trouble if I don’t ” (external regulation), and “but I really feel I am wasting my time in PE” (amotivation).

Data Collection Procedure

Data were collected during students’ regular physical education classes in the gymnasium by researchers, teachers, and trained data collectors. To minimize the threat to reliability with respect to the discrepancies among teachers and data collectors, both physical education teachers and data collectors were trained by the researchers with established data collection protocols. Data collectors received a three-day training before they entered the schools. In the training sessions, they were given data collection protocols and learned the policies and regulations of public schools. They also practiced data collection procedures and conducted inter-observer agreement reliability checks. In addition, teachers and data collectors received a detailed timeline for administering

surveys to secure the consistency of the protocol across sites. Step-by-step instructions for administering each instrument were attached on each envelope of surveys for teachers and data collectors to review before administering the instrument.

To secure the independence of students' responses during the data collection, students were told to work on the surveys individually and to respond truthfully to each item. Survey administrators read the items aloud to students and answered questions that students raised. All students were informed that their teachers would not have access to their individual responses and would not use their responses for grading purpose.

Data Analysis

After the descriptive inspection of data distribution and reliability, we used the structural equation modeling method (SEM) to test the hypothesized model (see Figure 1). SEM is a statistical procedure that allows the researcher to address theory-driven causal research questions for both latent variables and the measurement models (Hancock & Mueller, 2006). Using SEM, researchers can test an entire system of structural equations simultaneously to determine how well the data fit the model so as to project the tenability of the theory. Structural equation modeling also provides estimates of error variances in order to correct for measurement error. The SEM analysis in this study consisted of two steps. First, measurement model specification was performed. At this step, an initial measurement model where all factors were allowed to covary was tested. Three innate need satisfactions were allowed to covary because they are assumed to relate to each other theoretically. Similarly, different types of self-determined motivation also share a certain degree of communalities and they were also allowed to covary. This step was conducted to test the factor structures of the need satisfaction and self-determined

motivation instruments. It was hypothesized that the measurement model would fit this data set so that the further structural model analysis could be conducted. Statistically, if the results of the confirmatory factor analysis suggested that data did not fit the initial measurement model, an appropriate respecification of the measurement model might be needed. The second step, then, was to examine the tenability of the structural model. At this step, an initial structural model was tested by imposing a priori, theory-derived structural hypotheses on latent variables in the final measurement model. Similar to the first step, if the data did not fit the hypothesized model, a theory-based defensible respecification might be conducted to generate alternative models as needed.

Joint criteria to evaluate the model-data fitness recommend by Hu and Bentler (1999) were used. The set of criteria include the use of the standardized root mean square residual (SRMR) along with one or more incremental or absolute Goodness-of-Fit indices to determine the data-model fit. A good fit is characterized by the results that meet one of the following two joint criteria: Non-Normed Fit Index (NNFI), Comparative Fit Index (CFI) $\geq .96$ and SRMR $\leq .09$; OR SRMR $\leq .09$ and Root Mean Square Error of Approximation (RMSEA) $\leq .06$ (Hu & Bentler, 1999). The criteria are applicable to both measurement model testing and structural model testing.

Results

Descriptive Statistics and Internal Reliabilities

Table 1 shows the descriptive statistics and Cronbach's alphas for all measures. The variables' means and standard deviations represent composite scores from the subscales. As shown, students reported moderate to high autonomy, competence, and relatedness need satisfaction in their physical education classes. Table 1 also shows that

students had relatively high self-determined motivation (intrinsic motivation and identified regulation), moderate controlled motivation (introjected regulation and external regulation), and low amotivation. All the subscales had internal reliabilities above .70, suggesting that these measures were internally consistent.

Measurement Model Analysis

The analysis was performed using a confirmatory factor analysis. The measurement model testing confirmed that the need satisfaction and self-determined motivation constructs are tenable in 6th grade middle school physical education. All the measured variables significantly loaded on their corresponding factors. Factor loadings ranged from .501 to .870 (Table 2).

The indices of Goodness-of-Fit tests for this data set show that the constructs of need satisfaction and motivation types fit well with the students' responses. In this study, SRMR is .066 for and RMSEA is .055, which indicated an excellent fit between the theorized factor structure and the data. Coefficient for the construct reliability (ρ) of the measurement model is .924, indicating that the measurement model is reliable and replicable. The fit indices and the reliability coefficients suggest that there was no need for model respecification. The structural model analysis could be conducted on the data.

Structural Model Analysis

A priori, theory-derived structural hypotheses on the latent variables (Figure 1) in the previous confirmatory model was examined. Model-data fit was evaluated using the goodness-of-fit indexes we discussed previously. The Goodness-of-Fit test revealed that the hypothesized model fit the data very well. Specifically, with respect to the joint

criterion, SRMR is .071 for and RMSEA is .056. The construct reliability coefficient is .926 and the model is deemed highly reliable and replicable.

Although the hypothesized model fits the data very well, the theorized (hypothesized) relationships between the need satisfaction and self-regulatory motivation types were not fully supported by the SEM results. The standardized parameter estimates in Table 3 showed that need satisfaction of autonomy contributes to intrinsic motivation, identified regulation, and introjected regulation, but not to external regulation and amotivation. Satisfaction of competence need is found to contribute to students' intrinsic motivation and identified regulation and negatively predict amotivation. The hypothesized paths between competence need satisfaction and introjected regulation and external regulation are not supported by the data. Contradictory to the hypothesis and the theory, students' need satisfaction of relatedness positively contributed to their amotivation. Figure 2 reports the hypothesized model with significant paths. The three needs satisfaction together accounted for 47.7%, 49%, 18%, 1.1% and 8.5% of the variances in intrinsic motivation, identified regulation, introjected regulation, external regulation, and amotivation, respectively. In addition, the relationships among three needs satisfaction were moderate (path coefficients ranging from .365 to .508).

Discussion

The purpose of this study was to explore the relationships between perceived need satisfaction and self-regulated motivation in sixth grade physical education students. The data showed that students in general were satisfied in physical education in terms of autonomy, competence, and relatedness. Results suggested that the satisfaction of each innate need contributed differently to various self-regulated motivations. Most saliently,

the satisfaction of autonomy and competence contributed to students' intrinsic motivation and identified regulation. Unexpectedly, the satisfaction of the relatedness need contributed to amotivation in physical education. These findings suggest uniqueness of SDT based motivation in physical education and have significant pedagogical implications in that the findings provide a lens for examining specific motivation function of satisfying each need.

From a social constructivist learning perspective, students are active learners who are actively constructing the knowledge and skills in schools. In other words, students create their own meanings of realities and act upon them (Covington, 1983). During this process, it is assumed that when individuals' needs such as establishing a sense of belonging, competence, and autonomy are fulfilled, the construction of knowledge is more likely to be veridical and may lead to adaptive behaviors (Covington, 1983; Maehr, 1983; Nicholls, 1983). Based on the studies in science education, Maehr (1983) concluded that although a controlling learning environment is positively associated with students' immediate and short-term learning achievement, it will discourage students' continuing motivation in learning science in the long run. Furthermore, he (Maehr, 1983) argued that learning is an autonomous process in nature and it is important for teachers to adopt instructional strategies that provide students with more opportunities to practice autonomous learning.

Motivational Function of Autonomy

The results in this study clearly showed that students' need satisfaction for autonomy was highly salient in physical education and, more importantly, contributed to the variability in intrinsic motivation and identified regulation. It is reasonable to assume

that the need for autonomy is essential for generating the more self-determined motivation such as identified regulation and intrinsic motivation. The analyzed model also suggested that there is no meaningful relationship between satisfying autonomy need and externally regulated motivation and amotivation. This finding may suggest, importantly, that the lack of satisfaction for autonomy may not necessarily lead to amotivation or external regulation in physical education. It could be speculated that the results were due to students' realization from long experience of schooling that schools and their education experiences are inevitably controlled by others regardless of the autonomous experiences they have in physical education.

Overall, the finding about the satisfaction for autonomy need is encouraging due to its positive influence on fostering students' intrinsic motivation and the identified regulation. More specifically, the results indicated that providing an autonomous learning environment is likely both to increase student intrinsic motivation and to help them become identified with expected values in the physical education content. Pedagogically, teachers should treat students as the center of learning and organize opportunities for students to take initiative in their learning process.

The satisfaction for autonomy need also contributed to introjected regulation. This finding is in agreement with the findings from one study (Standage, Duda, & Ntoumanis, 2003) but is contrary to another (Ntoumanis, 2001). Introjected regulation is an important self-regulated motivation process in which students become better able to control their learning behavior as a result of internalizing a previously established external control protocol, such as teacher's disciplinary rules. Adopting the introjected regulation, students are establishing an internal representation of the external controls (Deci & Ryan,

1985; Ryan & Deci, 2000) and become more likely to engage in an activity without external contingencies, such as rewards, and to better monitor their behaviors. There are many instances in physical education where instructional routines are designed to allow students to engage in exercises or practices by themselves. These instances include warm-up routines, station practice for fitness development or skill practices. These instructional strategies, observed in many lessons during the data collection, might have functioned to help the students realize a need to avoid violating their teachers' instructional rules.

Motivational Function of Competence

As we hypothesized, the results demonstrate that satisfaction for the competence need led to intrinsic motivation and identified regulation. More importantly, data reported in figure 2 also indicated that the increase of the satisfaction for competence will reduce amotivation. These results are consistent with SDT theoretical articulation (Ryan & Deci, 2000) and the research findings in physical education that helping learners develop competence enhances learner motivation (Standage, Duda, & Ntoumanis, 2003). The findings clearly call for physical educators to focus on students' knowledge and skill development to the extent that students themselves become satisfied with the competence development.

It has been noted by researchers (Chen & Ennis, 2004) that there might be a conflict between achieving competence-based learning goals and providing non-competence oriented, enjoyable experiences in teaching physical education. Physical educators tend to use motivation strategies as a booster separate for subsequent learning of content, rather than an integral part of the content (Chen, 2001). This use of motivation

strategies leads students to improved engagement in activities that may not contribute to learning (Chen, 2001; Shen, McCaughtry, Martin, & Dillion, 2006). The findings about motivational function of the satisfaction for the competence need suggested that focusing on student competence development is a viable motivation strategy. Further, the findings also imply that it may be more important for teachers to help students become satisfied with their knowledge and skill growth than to simply help them develop knowledge and skill.

Even though Ntoumanis (2001) concluded that competence also contributed to introjected regulation and negatively predicted external regulation, the path from the satisfaction of competence need to introjected regulation was not statistically significant. In addition, SEM analysis suggested that the satisfaction of competence need has no connection to the external regulation. Taken together, the findings about motivational function of satisfying the competence need call for heightened attention to students' need for competence, not only for the purpose of attaining knowledge and skills, but also for the purpose of motivating them to continue learning in physical education. To do so, Connell (1991) suggested that competence can be facilitated by providing instructional structures involving effective communication of realistic expectations, consistent criteria, and competence-based feedback. In physical education, research also suggests that an environmental emphasis on students' self-improvement (Ntoumanis, 2001) or a climate promoting students' personal responsibility and self-confidence will fulfill students' need for competence (Standage, Duda, & Ntoumanis, 2003).

Motivational Function of Relatedness

The need satisfaction of relatedness was not found to affect intrinsic motivation or any type of extrinsic motivation. An unexpected finding is that the satisfaction for the relatedness need led to amotivation. The finding is inconsistent with the SDT theoretical articulation and contradictory to findings in previous studies (e.g., Standage, Duda, & Ntoumanis, 2003). A possible interpretation is that the satisfaction of the relatedness need in physical education may not be necessarily based on motivation to learn. Some cases, students may find it more important to maintain their friendship at the expense of learning. For instance, Hastie and Pickwell (1996) reported that middle school students tended to go through the motion in learning (amotivation), but kept intensive interactions with their friends in physical education. Similarly, Ennis (1994) reported that students were more likely to be disengaged in an activity when their peer groups considered it as boring or not interesting. Consequently, students may experience high satisfaction in relating to their peers in physical education. But the satisfaction may lead them away from motivation, or to becoming amotivated in terms of class activities.

From a social development perspective, children and adolescents establish relationships with their peers, develop a sense of belongingness, and behave in ways that are valued by peers in their daily life at school (Wentzel, 1999). During the process, it is likely that the development of relatedness proceeds achieving learning goals in education. Most of the time, students find it extremely difficult to neglect the demands from peers and feel that they should comply with the wishes attached to their peer groups, otherwise they would be isolated by the peer group (Ennis, 2003). The data seem to suggest that the relatedness nurtured in physical education may not be beneficial to motivation to learn physical education content.

A caution should be raised regarding the finding. According to the social constructivist learning theory, a critical type of interaction that facilitates motivation for learning is the one between the learner and knowledgeable and/or experienced others. In other words, constructive interaction for learning relies on reciprocity of social-interaction between the knowledgeable and novice (Oldfather & Dahl, 1994). In this study and other previous studies, the measure of the satisfaction for relatedness need did not distinguish the nature of the relatedness. It is not clear whether the relatedness is based on friendship or learning.

In recent years, physical education researchers have advocated using social constructivism as an alternative theoretical perspective on student learning to reform school physical education (Ennis, 2000, 2003; Kirk & Macdonald, 1998; Rovegno & Kirk, 1995). In addition, the advantages of cooperative learning and social interaction have been widely recognized by physical educators. The findings in this study, however, warn us that teachers should not assume that peer interaction are based on the content or learning. The data from this study clearly showed that satisfying students' need for relatedness may be counter-productive in terms of learning motivation. When teachers promote peer interaction, they need to understand the nature of students need for relatedness and plan and organize in-class peer interactions centering on learning.

Conclusion

In this study, we hypothesized that students' innate need satisfaction for autonomy, competence, and relatedness would contribute to students' intrinsic motivation, identified regulation, and introjected regulation and lessen external regulation and amotivation in six grade physical education students. Overall, the structural equation

model resulted from the data partially supported our hypotheses. In summary, the findings suggested that need satisfaction of autonomy and competence account for a large part of variability in intrinsic motivation and identified regulation. Satisfying the need for autonomy may contribute to students' introjected regulation as well. However, satisfying any of the needs does not seem to contribute to external regulation, the very basic type of extrinsic motivation. Further research is needed to investigate the antecedents of external regulation. Consistent with both theoretical articulations and previous findings, the satisfaction of the competence need was found to lessen amotivation. This finding supported the notion that the more satisfied students are with their competence, the less likely they will be in an amotivation state. The SEM model also revealed an unexpected finding about the satisfaction for the relatedness need, suggesting that satisfying students' need for relatedness in physical education may lead to a maladaptive consequence: amotivation. The finding suggests that cautions need to be taken when we encourage peer social interaction in physical education and warrants further study on the motivational function of peer socialization.

The findings provide additional evidence about the motivational function of the need satisfaction for autonomy, competence, and relatedness in 6th grade middle school physical education. It is clear that SDT based motivation strategies should be centered on content-related development of students' satisfaction for autonomy, competence, and relatedness needs. In addition, learning in physical education is a process in which learner motivation can be influenced by many factors in various patterns. Physical educators should be encouraged to adopt evidence-based practices to plan, organize, and deliver motivation strategies conducive to learning achievement.

Reference

- Covington, M. (1983). Motivated cognitions. In S.G. Paris, G.M. Olson, & H.W. Stevenson (Ed.), *Learning and motivation in the classroom* (pp. 139-164). Hillsdale, NJ: Lawrence Erlbaum Associates.
- Covington, M., & Dray, E. (2002). The developmental course of achievement motivation: A need-based approach. In A. Wigfield & J.S. Eccles (Eds.), *Development of achievement motivation* (pp. 33-57), San Diego, CA: Academic Press.
- Chen, A. (2001). A theoretical conceptualization for motivation research in physical education: An integrated perspective. *Quest*, 53, 35-58.
- Chen, A., & Ennis, C. D. (2007). *Evaluation report for Project Learn for Life: 2006-07 school year*. University of Maryland, Department of Kinesiology Pedagogy Studies Laboratory
- Deci, E.L., Eghrari, H., Patrick, B.C., & Leone, D.R. (1994). Facilitating internalization: The self-determination theory perspective. *Journal of Personality*, 62, 119-142.
- Deci, E.L., & Ryan, R.M. (1985). *Intrinsic motivation and self-determination in human behavior*. New York: Plenum.
- Deci, E.L., & Ryan, R.M. (2000). The “what” and “why” of goal pursuits: Human needs and the self-determination of behavior. *Psychological Inquiry*, 11, 227-268.
- Eccles, J., Adler, T.F., Futterman, R., Goff, S.B., Kaczala, C.M., MEECE, J.L., & Midgley, C. (1983). Expectancies, values and academic behaviors. In J.T. Spence (Ed.), *Achievement and achievement motivation* (pp. 75-146). San Francisco: W.H. Freeman.
- Ennis, C.D. (1994). Urban secondary teachers' value orientations: Delineating curricular

- goals for social responsibility. *Journal of Teaching in Physical Education*, 13, 163-179.
- Ennis, C.D. (2000). Canaries in the coal mine: Responding to disengaged students using theme-based curricula. *Quest*, 52, 119-130.
- Ennis, C.D. (2003). Using curriculum to enhance student learning. In S.J. Silverman and C.D. Ennis (Ed.), *Student learning in physical education* (pp. 147-163). Champaign, IL: Human Kinetics.
- Gouda, M., & Biddle, S. (1994). Perceived motivational climate and intrinsic motivation in school physical education classes. *European Journal of Psychology of Education*, 9, 241-250.
- Hagger, M.S., Chatzisarantis, N.L.D., Culverhouse, T., & Biddle, S.J.H. (2003). The processes by which perceived autonomy support in physical education promotes leisure-time physical activity intentions and behavior: A trans-contextual model. *Journal of Educational Psychology*, 95, 784-795.
- Hagger, M.S., Chatzisarantis, N.L.D., Barkoukis, V., & Wang, C.K.J. (2005). Perceived autonomy support in physical education and leisure-time physical activity: A cross-cultural evaluation of the trans-contextual model. *Journal of Educational Psychology*, 97, 376-390.
- Hancock, G.R., & Mueller, R.O (Eds.). (2006). Structural equation modeling: A second course. Greenwich, CT: Information Age Publishing, Inc.
- Hastie, P. A., & Pickwell, A. (1996). Take your partners: A description of a student social system in a secondary school dance class. *Journal of Teaching in Physical Education*, 15, 171-187.

- Hu, L., & Bentler, P.M. (1999). Cutoff criteria for fit indexes in covariance structure analysis: Conventional criteria versus new alternatives. *Structural Equation Modeling, 6*, 1-55.
- Kirk, D. & Macdonald, D. (1998). Situated learning in physical education. *Journal of Teaching in Physical Education, 17*, 376-387.
- Maehr, M.L. (1983). On doing well in science: Why Johnny no longer excel; why Sarah never did. In S.G. Paris, G.M. Olson, & H.W. Stevenson (Ed.), *Learning and motivation in the classroom* (pp. 179-210). Hillsdale, NJ: Lawrence Erlbaum Associates.
- McAuley, E., Duncan, T., & Tammen, V.V. (1989). Psychometric properties of the intrinsic motivation inventory in a competitive sport setting: A confirmatory factor analysis. *Research Quarterly for Exercise and Sport, 60*, 48-58.
- Nicholls, J.G. (1983). Conceptions of ability and achievement motivation: A theory and its implication for education. In S.G. Paris, G.M. Olson, & H.W. Stevenson (Ed.), *Learning and motivation in the classroom* (pp. 139-164). Hillsdale, NJ: Lawrence Erlbaum Associates.
- Nicholls, J.G. (1984). Achievement motivation: Conceptions of ability, subjective experience, task choice, and performance. *Psychological Review, 91*, 328-346.
- Ntoumanis, N. (2001). A self-determination approach to the understanding of motivation in physical education. *British Journal of Educational Psychology, 71*, 225-242.
- Ntoumanis, N. (2005). A prospective study of participation in optional school physical education using a self-determination theory framework. *Journal of Educational Psychology, 97*, 444-453.

- Oldfather, P., & Dahl, K. (1994). Toward a social constructivist reconceptualization of intrinsic motivation for literacy learning. *JRB: A Journal of Literacy*, 28, 129-158.
- Pintrich, P.R. (2003). A motivational science perspective on the role of student motivation in learning and teaching contexts. *Journal of Educational Psychology*, 95, 667-686.
- Renninger, K.A., Hidi, S., & Krapp, A. (1992). *The role of interest in learning and development*. Hillsdale, NJ: Erlbaum.
- Richer, S., & Vallerand, R.J. (1998). Construction and validation of the perceived relatedness scale. *Revue Europe'ene de Psychologie Applique'e*, 48, 129-137.
- Rovegno, I., & Kirk, D. (1995). Articulations and silences in social critical work on physical education: Towards a broader agenda. *Quest*, 47, 447-474.
- Ryan, R.M. & Connell, J.P. (1989). Perceived locus of causality and internalization: Examining reasons for acting in two domains. *Journal of Personality and Social Psychology*, 57, 749-761.
- Ryan, R.M., & Deci, E.L. (2000a). Self-determination theory and the facilitation of intrinsic, social development, and well-being. *American Psychologist*, 55 (1), 68-78.
- Ryan, R.M. & Deci, E. (2000b). Intrinsic and extrinsic motivation: Classic definitions and new directions. *Contemporary Educational Psychology*, 25, 54-67.
- Ryan, R.M. & Powelson, C.L. (1991). Autonomy and relatedness as fundamental to motivation and education. *Journal of Experimental Education*, 60 (1), 49-66.
- Shen, B., McCaughtry, N., Martin, J., & Dillion, S. (2006). Does "Sneaky Fox" facilitate

learning? Examining the effects of seductive details in physical education.
Research Quarterly for Exercise & Sport, 77, 498-506.

Standage, M., Duda, J.L., & Ntoumanis, N. (2003). A model of contextual motivation in physical education: Using constructs from self-determination and achievement goal theories to predict physical activity intentions. *Journal of Education Psychology*, 95, 97-110.

Standage, M., Duda, J.L., & Ntoumanis, N. (2005). A test of self-determination theory in school physical education. *British Journal of Educational Psychology*, 75, 411-433.

Wentzel, K.R. (1999). Social-motivational processes and interpersonal relationships: Implications for understanding students' academic success. *Journal of Educational Psychology*, 91, 76-97.

Table 1. Means, Standard Deviations, and Cronbach's Alphas for All Subscales

	Mean	SD	α
<i>Need satisfaction</i>			
Autonomy	4.51	1.27	.71
Competence	5.67	1.20	.83
Relatedness	4.82	1.41	.87
<i>Motivational types</i>			
Intrinsic motivation	5.59	1.42	.90
Identified regulation	5.65	1.33	.83
Introjected regulation	4.29	1.49	.76
External regulation	4.11	1.64	.80
Amotivation	2.54	1.57	.83

Table 2 *Factors Loadings in the Measurement Models*

	V1	V2	V3	V4	V5
Need satisfaction					
Autonomy	.538*	.635*	.501*	.666*	.599*
Competence	.834*	.797*	.619*	.813*	.523*
Relatedness	.702*	.812*	.871*	.819*	.563*
Self-determined motivation					
Intrinsic motivation	.719*	.870*	.863*	.875*	
Identified regulation	.570*	.748*	.720*	.857*	
Introjected regulation	.677*	.595*	.645*	.675*	
External regulation	.649*	.563*	.798*	.742*	
Amotivation	.591*	.788*	.811*	.763*	

Note. * $p < .05$. V: measured variables.

Table 3 *Standardized Parameter Estimates*

Path	Parameter estimate
Autonomy → Intrinsic motivation	.419*
Autonomy → Identified regulation	.477*
Autonomy → Introjected regulation	.356*
Autonomy → External regulation	-.045
Autonomy → Amotivation	-.035
Competence → Intrinsic motivation	.369*
Competence → Identified regulation	.284*
Competence → Introjected regulation	.065
Competence → External regulation	.013
Competence → Amotivation	-.308*
Relatedness → Intrinsic motivation	.068
Relatedness → Identified regulation	.101
Relatedness → Introjected regulation	.066
Relatedness → External regulation	.113
Relatedness → Amotivation	.167*

Note. * $p < .05$

Figure Caption

Figure 1. The Hypothesized Structural Model

Figure 2. Hypothesized Model Examined in SEM (only significant paths are presented)

Figure 1. The hypothesized structural model.

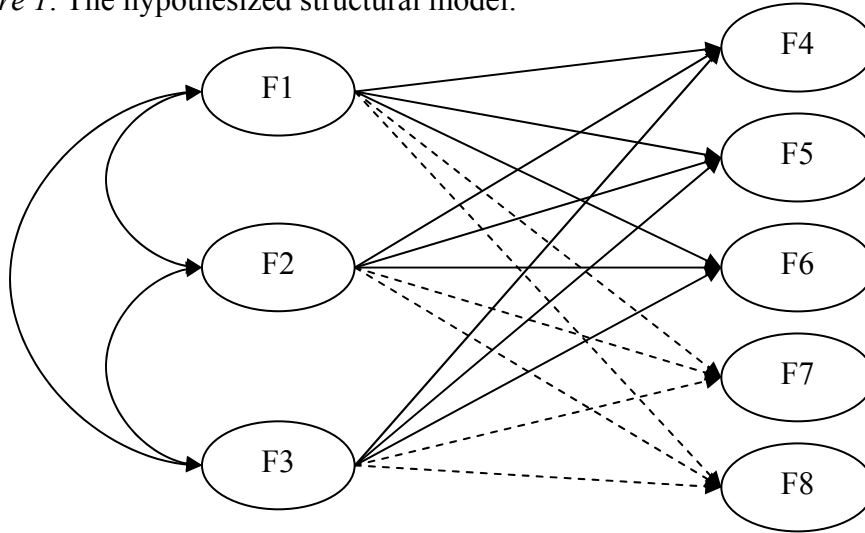

Note: Solid lines indicate positive relationships; broken lines represent negative relationships. F1= need satisfaction of autonomy; F2= need satisfaction of competence, F3= need satisfaction of relatedness, F4= intrinsic motivation, F5= identified regulation, F6= introjected regulation, F7= external regulation, F8= amotivation;

Figure 2. Hypothesized model examined in SEM (only significant paths are presented).

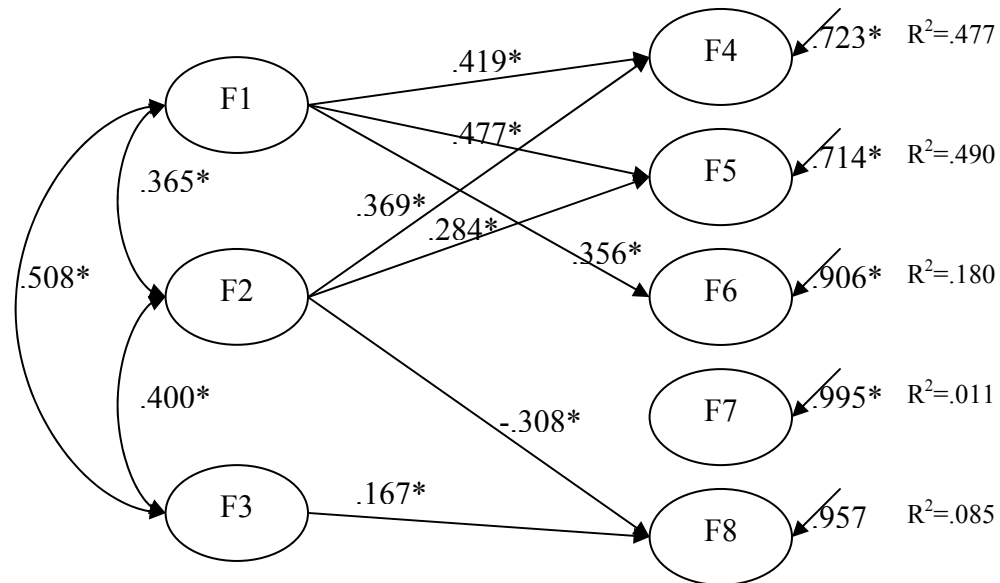

Note: F1= need satisfaction of autonomy; F2= need satisfaction of competence, F3= need satisfaction of relatedness, F4= intrinsic motivation, F5= identified regulation, F6= introjected regulation, F7= external regulation, F8= amotivation.

Motivated but Rarely Achieving: An Examination of 6th Graders' Self-Determined Motivation and Learning in Physical Education

A critical factor that often determines success and failure in learning is learner motivation (Pintrich, 2003). Alexander (2005) articulated that the very first step for educators to take is to understand the nature of learner motivation in order to foster a positive motivation experience for learners. Without this understanding, Alexander (2005) argued, it will be very difficult for educators to engage students in learning to achieve learning goals. In physical education, Chen and Ennis (2004) suggested that it would be difficult for physical education teachers to help students develop healthy, physically active life without appropriate motivational strategies. The purpose of this study, therefore, was to examine the relationship between a motivation construct (self-determination) and learning in middle school physical education. We believe that the study will help us understand students' motivation development in relation to their adoption of different behavioral regulation strategies that may lead to learning achievement.

Self-Determination Theory

Self-determination theory (SDT) explains human motivation by focusing on the importance of human inner resources for development and behavioral regulation (Ryan & Deci, 2000a). In SDT, motivation can be understood in three basic states, intrinsic motivation, extrinsic motivation, and amotivation. *Intrinsic motivation* indicates that individuals engage in an activity for the sake of the activity itself and for the satisfaction inherent in performing the activity (Deci & Ryan, 1985). An intrinsically motivated person engages in an activity to experience interest and enjoyment in the interaction with

the activity rather than external pressures or rewards received during or after the interaction. The notion that intrinsic motivation can result in adaptive cognitive, affective, and behavioral outcomes has been widely documented in research studies and broadly acknowledged by educators. For example, Ryan and Deci (2000a) concluded that intrinsically motivated students demonstrate better school adjustment than students who are not intrinsically motivated. Specifically, intrinsically motivated students demonstrate better performances, better engagement, higher quality learning behavior, and a lower dropout rate (Ryan & Deci, 2000a).

In school-based learning, however, rarely is the learner motivation completely intrinsic. Often times it is externally regulated. For example, students may work on homework not because homework is fun or interesting or enjoyable to them but because they want to receive good grades, praise from their teachers, or to avoid negative academic consequences. In physical exercise for example, people often exercise for the purpose of losing or controlling weight rather than for the enjoyment of the exercises. These examples suggest that the motivation behind these activities is extrinsic and may well be dependent upon external rewards (good grades, praises, weight loss, etc.). This type of motivation is defined as extrinsic motivation in SDT. According to SDT, *extrinsic motivation* refers to performing an activity because the activity will lead to a separable outcome (Ryan & Deci, 2000b).

There is also a situation in which individuals are neither intrinsically nor extrinsically motivated. SDT conceptualized the absence of motivation as amotivation. *Amotivation*, thus, refers to situations where an individual lacks the intention to act (Ryan & Deci, 2000a). When an individual is in the state of amotivation, he/she either does not

take part in the activity at all or just goes through the motion without intent (Ryan & Deci, 2000a). Research in physical education has revealed that amotivation leads to maladaptive consequences, such as boredom (Ntoumanis, 2001) or lack of intention to participate in after-school physical activities (Standage et al., 2003).

The Motivation Regulation Processes

Extrinsically motivated behaviors require provision of external factors (Deci & Ryan, 1985). The external factors, such as rewards, praises, or punishment, function to impose an externally controlled regulation to the individual to bring about and reinforce the desired behavior. Because many extrinsic contingency mechanisms (including rewards) may have detrimental effects on intrinsic motivation (Deci et al., 1999), what types of external control and how to use external controls to regulate behavior without decreasing intrinsic motivation have become central to SDT (Deci & Ryan, 1985). Further, Deci and Ryan (1985) argued that there must be a process of internalization through which an individual gradually acquires the value or belief central to the external regulation mechanism (along with its necessary extrinsic contingencies) and transforms it into a personal belief based on which the individual regulates the behavior in the similar environment, such as in schools.

Internalization is a constructive process that involves resolving the inherent conflict between autonomy (what one would do naturally) and external control (what one is being asked to do) (Deci & Ryan, 1985). The process consists of four types of behavioral regulations of extrinsic motivation. Based on different degree of autonomy and external control involved in the process, these behavior regulation mechanisms are

named: *External regulation*, *Introjected regulation*, *Identified regulation*, and *Integrated regulation* (e.g., Deci & Ryan, 1985).

The different types of motivation reflect different degrees to which the value of the required behavior has been regulated by the individual. According to SDT, *self-regulation* is “the energization and guidance of behavior on the basis of integrated awareness, informed by basic needs” (Ryan & Deci, 2000c, p. 47). A true self-regulated behavior represents the acceptance of an activity based on an individual’s integration of one’s own needs, values, and judgments in the activity. In other words, self-regulation is the processes through which individuals internalize and integrate external values and behavioral regulations into their own.

Among the four types of extrinsic motivation, the least self-determined form is *external regulation*. This is the regulation that an individual adopts in order to satisfy an external demand or to receive the reward contingency (Ryan & Deci, 2000b). External regulation occurs when one is anticipating a certain outcome associated with the required behavior. For example, a student may participate in a running program because he/she will be rewarded for participation (e.g., a T-shirt or hat), despite that the student does not like running.

Introjected regulation refers to partial or suboptimal internalization in which the individual does not fully identify with the value or regulatory process and does not accept it as his/her own (Deci, Eghrari, Patrick, & Leone, 1994). But the individual regulates his/her own behavior to comply with the behavioral expectation of having to rather than wanting to (Deci & Ryan, 1985). For instance, a student participates in running to avoid a feeling of guilt for not engaging in class activities.

A more self-determined form of extrinsic motivation is *identified regulation*, which means regulation through personal identification with the desired behavior (Ryan & Deci, 2000b). An individual with identified regulation demonstrates more self-determination as he/she has accepted the form of regulation as personally important and has identified self with the regulation process. For example, a student participates in running because he/she understands and believes running to be beneficial to his/her health.

The most self-determined type of extrinsic motivation is *integrated regulation*. Integration refers to optimal internalization resulting in self-determination and is necessary for controlled behaviors to become autonomous (Deci et al., 1994; William & Deci, 1996). It allows the individual evaluates the identified regulations and brings the values of the regulation into congruence with one's other values and needs for life (Deci & Ryan, 1985). In running for example, students with integrated regulation motivation believe in the values the teacher has conveyed to them in running and incorporate running in their daily lives. They become not only active runners in physical education, but also adopt the behavior in their lives outside physical education.

Motivation and Learning in Physical Education

Classroom-based research on SDT has revealed that intrinsic motivation and identified regulation will lead to better academic achievement, while less self-determined motivation such as external regulation is related to maladaptive outcomes. In physical education, research on SDT has shown that intrinsic motivation positively predicted students' effort (Ntoumanis, 2001), concentration level (Ntoumanis, 2005; Standage, et al., 2005), preference to attempt challenging tasks, positive affect (i.e., happy, satisfied,

excited, and relaxed) (Standage, et al., 2005), intension of being physically active after school (Ntoumanis, 2001, 2005; Standage, et al., 2003), and negatively predicted negative affect (e.g., disappointed, embarrassed) (Ntoumanis, 2005). In addition, students' intrinsic motivation in compulsory physical education had significant effects on their choice decisions for participation in optional physical education (Ntoumanis, 2005). In contrast, amotivation has been found leading to maladaptive consequences, such as boredom (Ntoumanis, 2001) or lack of intention to participate in after-school physical activities (Standage et al., 2003). These findings have contributed to our knowledge of the functions of different types of motivation in physical education. However, learning is clearly absent in these studies as a measured variable. It is important to measure learning achievement in order to have a more comprehensive understanding of how students' motivational experience contributes to their learning.

Learning in physical education is defined as a relatively permanent behavioral change resulting from experiencing physical movement associated with cognitive understanding of the movement (Rink, 2001). Usually, cognitive knowledge and motor skill acquisitions are central indicators of student learning in physical education. These indicators can be documented in student performance on achievement tests of cognitive knowledge and skills as well as reflected, in part, in in-class physiological intensity (Chen & Ennis, 2004).

Extensive research on motivation has been conducted in physical education with different theoretical frameworks such as achievement goals, expectancy-values, and interests. The findings have contributed to our understanding of motivation sources and their functions in physical education in terms of student behavior, class environment, and

task design with the apparent lack of connection between motivation, motivated learning behavior, and learning outcomes. For example, the findings from the few studies that actually measured students' goal orientations and learning outcomes (e.g., Berlant & Weiss, 1997; Chen & Shen, 2004; Solmon & Boone, 1993) suggest a rather weak association between the mastery/task goal orientation and students' adaptive learning behaviors and achievement. In research on interest, for another instance, students' individual interest was not found to be directly relate to learning outcomes (Chen & Shen, 2004) and situational interest might not lead students to a high level of knowledge and skill acquisition in physical education (Shen, Chen, Scrabis, & Tolley, 2003).

It is argued (Chen & Ennis, 2004) that the weak connection between learner motivation and learning may be, in part, due to the reality that few learning-based outcomes are included in physical education. In other words, teachers rarely demand that students learn and achieve. When achievement is absent or the degree of learning varies little (low variability), the connection between learner motivation and learning may be difficult to identify. In this case, it stands to reason that students are likely to be motivated to engage in in-class activities in physical education, but the activities are not structured for achieving particular competence goals.

In this study, we attempted to explore how critically each self-regulation process functions to contribute to or impede cognitive knowledge growth and motor skill improvement according to the theorized SDT model described in Figure 1. The model describes the relationship between the SDT motivation and learning. We hypothesized that students' intrinsic motivation and identified regulation would contribute to cognitive knowledge growth and motor skill learning, while the introjected regulation would not. In

addition, we hypothesized that the external regulation and amotivation would impede knowledge and motor skill learning. We believe that this study will extend the research on SDT to investigate its actual impact on students' learning achievement, a phenomenon that has rarely been examined in previous research in physical education. It is hoped that the results will provide useful information about the relationship between self-determined motivations and learning achievement that will guide effective development of learning-enhancing motivation strategies in the future.

Method

Setting and Participants

The study was conducted in a large school district on the East Coast of the United States that served 137,798 students, including 22.9% African Americans, 0.3% American Indians, 14.8% Asian Americans, 41.3% European Americans, and 20.7% Hispanic Americans; and 39% of the student population receive meal assistance (National Center for Education Statistics [NCES], 2006). This school district is also uniquely positioned to provide generalizable research results to urban and suburban school districts serving students from diverse ethnic, socio-economic, and urban/suburban backgrounds.

In April 2006, the County Board of Education passed the Policy for Wellness – Physical and Nutritional Health that calls for strengthening nutrition education and physical education programs to educate students to develop healthful, active life styles. Since 2005, prior to the issue of the policy, the district had begun to design an innovative physical education curriculum to achieve the physical education goals. This study was conducted before the new curriculum was actually implemented in the school district to determine the relationship between students' motivation and their learning outcomes in

the current curriculum setting. In other words, the physical education was still centered on the traditional multi-activity curriculum, in which a variety of sport and fitness units constitute the major content. Each week a total of 180 minutes was allocated for physical education and the students were required to take physical education in three of the four academic quarters throughout the year. All middle schools were equipped with at least one large gymnasium and adequate outside field space for current curriculum offerings.

Participants were 344 6th grade students from 15 middle schools randomly selected with stratifications on students' socio-economic background and school size from 38 middle schools in the school district. The final sample used in the data analysis consisted of 242 students who provided complete data sets. The students were from low, middle, and affluent socio-economic families, according to a 2005/2006 school report; and represented the following major ethnic groups, 22 % African American, 44.8% European American, 18.2% Hispanic American, 18.2% Asian American, and 0.3% Native American. All participants in the study had their parent permission and assented for participation as required by the IRB regulations. In addition, students were told that they could choose to withdraw whenever they decided to.

The primary reason to examine sixth grade students in the current study is that at this stage they are experiencing a physical education curriculum different from what they had in elementary school. Therefore, the knowledge and skill growth measured in the study can be largely attributed to the middle school curriculum. In other words, the internal validity for the measure of learning outcome might be better preserved.

Variables and Measures

In order to answer the research questions, the following variables were measured: (a) types of self-regulated motivations as specified in SDT, (b) cognitive knowledge, and (c) motor skills. Consistent with research in education and physical education, students' types of self-regulation in motivation included amotivation, external regulation, introjected regulation, identified regulation, and intrinsic motivation. Integrated regulation was not examined in this study because Ryan and Connell (1989) argued that elementary and middle school students are too young to have achieved a sense of integration with respect to school academic activities.

Self-Regulated Motivation

The types of self-regulated motivation were measured with a questionnaire adapted by Goudas and Biddle (1994) based on the original Self-Regulation Questionnaire (SRQ) designed by Ryan and Connell (1989). To adapt the questionnaire into physical education setting, Gouda and Biddle (1994) modified the questionnaire and established the construct validity of the measures using factor-analytical procedures. The modified SRQ has shown distinct factor structures for the SDT components and good internal reliability (Cronbach α ranging from .60 to .80). The adapted SRQ includes five four-item subscales that measure intrinsic motivation, identified regulation, introjected regulation, external regulation, and amotivation. The items are attached to a 7-point Likert type scales with the *Strongly Disagree* as 1 and the *Strongly Agree* as 7. Each item begins with a common stem "I take part in PE..." followed by the statement for rating such as "because PE is exciting" (intrinsic motivation), "because I want to learn sport skills" (identified regulation), "because I would feel bad about myself if I did not"

(introjected regulation), “because I will get into trouble if I don’t ” (external regulation), and “but I really feel I am wasting my time in PE” (amotivation).

Learning Achievement

In the present study, learning achievement was operationally defined as the degree to which students’ knowledge and psychomotor skill grew or improved after instruction. The cognitive knowledge was defined in the domain of health-related fitness concepts and principles of engaging in health-enhancing physical activities. Tests of whole body movement involving the arm striking skill, object-manipulation skill, and footwork movement skill were chosen to test psychomotor skills because of their functional implications to the life-long participation in a variety of physical activities.

Cognitive knowledge test. Students’ knowledge about physical activity and its benefits was assessed using a standardized knowledge test developed, validated, standardized by Zhu, Safrit, and Cohen (1999). The test questions were differentiated and validated for and examine concepts associated with the five major health-related fitness components and related principles. A total of 24 questions were split into two 12-question equivalent tests. The following are two sample questions.

Question 1: Ability of the heart, lungs, and blood vessels to function efficiently when a person exercises the body is .

- (a) Muscular endurance (b) Target heart rate (c) Cardiorespiratory fitness

Question 2: Teens who are at least moderately active and in good health are advised to work at .

- (a) Between 60 and 90 percent of their target heart rate range

- (b) 45 percent of their target heart rate range
- (c) Between 60 and 90 percent of their estimated VO2 max
- (d) 45 percent of their estimated VO2 max

As can be seen in the example, the questions were in the multiple-choice format. A correct answer was assigned a score of one; incorrect choice was assigned a score of zero (0). The maximum possible score a student may earn is 12. The total score represents the performance on the test and, consequently, represents how much a student knows about the content.

Motor skill tests. The movement test involving arm striking skill was the badminton striking skill. Arm striking is a fundamental movement that can be performed in different planes and is required in performing many physical movement forms involving the upper body (Gallahue, 1996). The striking pattern in the test may also be transferred to learning and playing tennis, racquetball, handball, and volleyball. Therefore, it has broad implication for future effective participation in physical activity. A test designed by Lockhart and McPherson (1949) was used in the study due to its standardized nature and accompanying validated norm for scoring. The test-retest reliability coefficient of this test has been reported to be .90 and validity coefficient has been reported to range from .71 to .90 by using criterion measures of judges' ratings and round robin tournament (Lockhart & McPherson, 1949). Figure 2 is a diagram of the test setup.

When taking the test, the student assumes a service stance in back of the starting line on the floor 6 ½ feet from and parallel to the base of the wall. On the signal "Ready, go!" the student serves the shuttle against the wall. The shuttle is then hit as many

times as possible during a 30-second time period, as long as the shuttle is hit from behind the restraining line, which is 3 feet from and parallel to the base of the wall, and above a 5-foot line on the wall. Three 30-second trials are taken. A 15-second practice session is permitted before testing. A point is scored each time the shuttle is hit during each trial and the total test score is the sum of the legal hits in three trials. The total score is the sum of the legal hits in each trial.

The second psychomotor skill test was the basketball control dribble test validated by American Alliance for Health, Physical Education, Recreation & Dance [AAHPRED] (1984). This test was designed to assess students' skill in handling and controlling a basketball while the body is moving. This test is important in that it emphasizes coordinated whole body movement, footwork, and object manipulation; all are fundamental skills for effective participation in health-enhancing physical activities. The validity of the test has been reported to range from .37 to .91 for both genders and the reliability has been showed to range from .93 to .97 for females and from .88 to .95 for males.

The test is administered in the regulation-size free-throw lane on the basketball court. Six cones are placed inside the lane as described in Figure 3. The student starts dribbling the basketball from the first cone (cone A) and weaved around the five cones in a fixed sequence as fast as he/she can without losing control of the ball (Figure 3). The left diagram in the Figure 3 is used for right-handed students and the right one for left-handers. On the signal "Ready, go!" students use the non-dominant hand to dribble the ball from cone A to the non-dominant side of cone B. Students can use either hand to dribble the ball. The time from the start to finish is recorded by a tester with a stopwatch.

The trial score is the time required to complete the course legally. The total test score is the sum of the times for two trials.

Data Collection Procedure

The researchers, participating teachers, and trained data collectors collected data during students' regular physical education classes in the gymnasium. The researchers established the testing protocols and provided series training to physical education teachers and data collectors. This effort was done to minimize the threat to reliability with respect to the discrepancies among the researchers, teachers, and data collectors. Physical education teachers were provided with detailed instructions for data collection and the opportunities to discuss the data collection protocols in a series of workshops. Data collectors received a three-day training before they entered the schools. In the training sessions, they studied data collection protocols and learned the policies and regulations of public schools. They also practiced data collection procedures and conducted inter-observer agreement reliability checks. In addition, teachers and data collectors received a detailed timeline for administering tests, surveys, and skills to secure the consistency of the protocol across sites. Step-by-step instructions for administering each instrument and test were attached so that the teachers and data collectors can review them before administering the instruments and tests.

Students' knowledge and physical skills were measured in a pre-test and post-test design to allow growth and improvements to be calculated. The pre-tests were conducted in the fall semester of 2006. Post-test data on knowledge and skill assessments were collected in the late spring of 2007. Knowledge growth and skill improvement scores were obtained by regressing the post-test scores on pre-test scores to control for ceiling

effects and any statistically significant discrepancies among groups of students on pretest scores. Students' self-determined motivation was measured in the spring semester 2007.

To secure the independence of students' responses during the data collection, the data collectors instructed students to work on tests and surveys individually and to respond to the items on the tests and surveys truthfully. Data collectors read the items on surveys and knowledge test to the students and answered questions that students raised. All students were informed that their teachers would not have the access to their individual responses and would not use their responses for the grading purpose.

Data Analysis

Individual students' responses to SDT survey and their residual gain scores of cognitive knowledge and motor skill tests were used in data analysis. Data were analyzed using the structural equation modeling method (SEM). SEM is a statistical procedure that allows the researcher to address theory-driven causal research questions for both latent variables and the measurement models (Hancock & Mueller, 2006). In the present study, we used SEM to examine the factor structure of SDT and test the hypothesized relationships between students' self-determined motivation and learning outcomes (Figure 1). The SEM analysis in this study consisted of two steps. First, measurement model specification was performed. At this step, the purpose was to examine construct validity evidence from the data by detecting possible discrepancies in relationships between measurement scores and the latent factors the scores were meant to examine. In the initial measurement model, the relationships were tested with all factors allowed to covary. Specifically, different types of self-determined motivation were allowed to covary because they share a certain degree of communalities theoretically. If the data did

not fit the initial measurement model, an appropriate respecification in this model might be need. The second step, then, was to examine the tenability of the structural model. At this step, the contribution of each self-regulated motivation to learning achievement was determined using the causal path modeling algorithm to verify if the contributions theorized in Figure 1 were valid. Specifically, an initial structural model was tested by imposing a priori, theory-derived structural hypotheses on latent variables in the final measurement model. If the data did not fit the hypothesized model, a theory-based defensible respecification might be conducted to generate alternative models as needed.

Results

Preliminary Analysis

The scores for all measures were reduced according to the requirement of each instrument and test to generate composite scores to represent the variables. Table 1 reports the descriptive statistics and Cronbach's alphas for all the measures. As shown, the students reported relatively high intrinsic motivation and identified regulation, moderate less self-determined motivation (introjected regulation and external regulation), and low amotivation. All subscales had internal reliability coefficients (α) above .70, suggesting that these measures met the required reliability and were internally consistent. With respect to skill and knowledge tests, students' badminton skill and health related fitness knowledge scores increased over the semesters. Because the basketball skill test was measured on the time students completed the trial, the larger number (longer time) indicated poorer performance. Therefore, table 1 demonstrates a slight decline of students' basketball dribble skill score from fall 2006 to spring 2007 semester.

In order to further examine students' knowledge change and skill improvement, we conducted a paired-sample t-test and computed the effect size of students' learning. The results, reported in Table 2, show that students' performed significantly better on knowledge test and badminton skill test in spring 2007 semester than they performed in fall 2006 semester. Although students' basketball dribble skill decreased over semesters, the results indicate that the difference between two semesters was not statistically significant ($p > .05$). Moreover, the values of effect size indicated small deterioration in basketball control-dribble skill, small gain in knowledge learning, and low-moderate gain in the badminton striking skill. Because the research interest was to examine the relationships between students' self-determined motivation and their knowledge gain and skill improvement, the basketball data were eliminated from the final SEM analysis due to the lack of improvement.

Confirmatory Factor Analysis

The purpose of this analysis was to confirm that the viable five-factor structure of SDT was maintained with SRQ in this sample so as to allow the further structural modeling analysis to be conducted. The relationship between measures and their latent factors was determined using the maximum likelihood method with all factors allowed to covary so that possible discrepant associations could be identified. The model-data goodness of fit was evaluated by the joint criteria recommend by Hu and Bentler (1999) where the standardized root mean square residual (SRMR) was used along with one or more incremental or absolute fit indices to determine the fit of the confirmatory factor model. The data-model fit can be considered good when the results meet one of the following two joint criteria: Non-Normed Fit Index (NNFI), Comparative Fit Index (CFI)

$\geq .96$ and $SRMR \leq .09$; OR $SRMR \leq .09$ and Root Mean Square Error of Approximation (RMSEA) $\leq .06$ (Hu & Bentler, 1999).

The indices of Goodness-of-Fit tests for this data set showed that the five-factor SDT model fit well with the students' responses. In this study, the RMSEA is .055 and SRMR is .066. In addition, results suggested that all the factor loadings are significant, which further indicates an excellent fit between the theorized factor structure and the data. The construct reliability coefficient (ρ) of the measurement model in this study is .875; deemed excellent. Reliability of the construct concerns with whether the hypothesized constructs can be expected to be stable and replicable. The good model-data fit, coupled with the high reliability, revealed that the self-determined motivation model could be used for the further structural model analysis and there was no need for model respecification.

Structural Model Analysis

The hypothesized relationships among the latent motivation constructs and knowledge and skill residual gains were examined using the maximum likelihood estimation method with EQS6.1 (Bentler, 2006). Goodness-of-fit indexes discussed previously were used to evaluate the model fit. The results of SEM suggested that the hypothesized model fit the data very well. Specifically, with respect to the joint criterion, SRMR is .062 and RMSEA is .039 in this study. The reliability coefficient is .580 that could be considered acceptable.

The standardized path coefficients for the hypothesized relationships are presented in Figure 4. As shown, the amotivation has a negative contribution to students' health related fitness knowledge gain. None of the other motivations, including intrinsic

motivation, identified regulation, introjected regulation, and external regulation, was found contributing to knowledge and skill learning achievement, either positively or negatively. Table 3 shows the correlations among the five different self-determined motivational types. Only the relationships among intrinsic motivation and external regulation and identified regulation and external regulation were found not significant. Overall, the model accounted for 7.3% and 3.2% of the variance in students' knowledge gain and badminton skill improvement.

Discussion

The Contribution Path of SDT to Learning

The present study aimed to explore the relationships between students' self-determined motivation and learning outcomes in middle school physical education. We hypothesized that (a) Students' intrinsic motivation and identified regulation will contribute to cognitive knowledge growth and motor skill learning while, (b) students' introjected regulation may not contribute to knowledge and motor skill learning, and (c) external regulation and amotivation may have detrimental impact on knowledge and motor skill learning. Results of SEM analysis only supported one hypothesized relationship: the link between amotivation and cognitive knowledge gain. It suggested that when students lack motivation, it is likely that they will learn relatively little cognitive knowledge.

In this study, the intrinsic motivation was not found to contribute to learning. In physical education, tangible learning outcomes as motivational consequences have received little empirical attention in the previous studies. The connection between intrinsic motivation and motivational consequence was only observed in students'

concentration level, preference to attempt challenging tasks, and positive affect (i.e., happy, satisfied, excited, and relaxed) among 950 British middle school students (Standage, et al., 2005). However, intrinsic motivation has been found to lead to positive consequences in other educational domains. For example, Deci et al. (1991) reported that students who reported high intrinsic motivation were more likely to demonstrate more engagement, lower dropout rate and better academic performance. It is surprising that the connection between intrinsic motivation and learning outcomes was absent in the physical education.

A possible explanation for the current findings may be that intrinsic motivation in physical education is often conceptualized and understood as fun, enjoyable experiences. In instruction, fun is considered a critical task-design priority. When it is overemphasized beyond the learning objectives, the fun factor may function as seductive details (Shen, McCaughtry, Martin, & Dillion, 2006) that suppress the intention to achieve the learning objectives. In other words, the content in the study were indeed intrinsically motivating and helped the students engage in the activities. The content, however, might provide “fun” and enjoyable experiences with little emphasis on learning knowledge and skills.

All three types of extrinsic motivation did not influence student learning. As we hypothesized, introjected regulation did not contribute to student knowledge and skill learning. Identified regulation, a more self-determined motivation, was not found to contribute to any learning achievement. External regulation, which was hypothesized to negatively affect student learning, had no relationships with knowledge gain or skill acquisition. Overall, the link between students’ extrinsic regulations and their learning in physical education was not found in the present study.

According to SDT (Ryan & Deci, 2000a), people often need to be motivated extrinsically, because not all human activities are equally intrinsically interesting, optimally challenging, and aesthetically pleasing to everyone. Many activities or tasks in the school and the contemporary society are likely lacking intrinsic motivation characteristics, but they are deemed necessary for students to master. From this perspective, it is critical to understand how extrinsic motivation affects ongoing activities and can be internalized (transformed) and how non-intrinsically motivated individuals become motivated to carry out activities necessary for them in physical education.

SDT Motivation, Learning Achievement, and the Curriculum

Overall, descriptive data analysis indicated that students in this study reported relatively high intrinsic motivation and identified regulation and low amotivation. In other words, the present study suggests that the students were relatively highly motivated in physical education. These findings seem to be inconsistent with other research results in education. Sixth grades were chosen in this study because they were on the transition from elementary to middle. During this period Wigfield and colleagues (Wigfield, Lutz, & Wanger, 2005) articulated that students experience many changes including biological changes and the social and educational changes related to the transition from elementary to middle school. These changes, according to Wigfield and colleagues (Wigfield, et al., 2005), may have a significant impact on students motivation and academic achievement. Moreover, Wigfield and colleagues (Wigfield, et al., 2005) indicated that this can be a time period in which students' motivation declines significantly and motivational problem, thus, can become more central during this time. However, the findings of this study suggested that students' motivation in the multi-activity oriented physical education

may not follow this pattern. Students seemed to perceive the activities in their physical education classes as fun or interesting and thus they may not lack the motivation toward those activities. Therefore, it is reasonable to assume that physical education is a motivating subject matter in comparison with general schooling. But the experiences in physical education may not lead to profound learning opportunities. In physical education, whether students are motivated does not seem to be an issue. The issue is what physical education curriculum can offer: fun and enjoyable experiences only, or meaningful and interesting knowledge and skill learning experiences?

What also seems problematic in the findings is that the high motivation did not contribute positively to learning achievement. Motivation is the process that energizes behavior and gives the behavior direction. We found that the 6th grade students were highly motivated in terms of the SDT constructs. However, the motivation did not result in tangible learning achievement. In other words, the students might have motivational energy but lack motivational direction. The possible issue of full motivational energy with unclear motivational direction (learning) seems to indicate a need for clearly distinguishing learning goals and non-learning goals (e.g., having fun) in designing a physical education curriculum (Chen & Ennis, 2004). The evidence from the current study shows that students were motivated, either extrinsically or intrinsically, in physical education. What needs to be questioned is to what end they devote their motivation? The students in this study might not have devoted their motivation to learning fitness knowledge and physical skills.

Although the t-tests showed that students' post-test scores of cognitive knowledge and badminton skill were statistically higher than their pre-test scores, students' learning

of health relatedness fitness knowledge and motor skills did not seem to be substantial according to the small effect sizes. Instead of improvement, students' basketball dribble skill decreased over the semesters. This is surprising in that basketball is one of the major content areas in the curriculum. Despite the fact that students performed significantly better on both the knowledge and badminton tests during the spring semester than they performed in the fall semester, their performance on posttest was not significant. Given the maximum score on the knowledge test was 12, students' posttest score (mean=6.08) suggested that students' only answered half of the questions correctly on average. Similarly, students' badminton posttest performance (mean=23.19) indicated that on average students did not master the skill according to the standard (38) of Lockhart-McPherson Badminton Playing Ability Test (Lockhart & McPherson, 1949).

More importantly, the fact that students learned little may help confirm the notion that students in physical education, unlike other school academic areas, have not been held accountable for their learning (Rink, Jones, Kirby, Mitchell, & Doutis, 2007). More than two decades ago, Goodlad (1984) found that physical education did not appear to have specific learning goals. Siedntop, Doutis, Tsangaridou, Ward, and Rauschenbach (1994) further pointed out that having fun seems to be a dominant goal and students learn little no matter how interested they are in physical education. Physical education professionals have advocated a standard-based curriculum reform aimed to set student learning goals, to engage student in the process of learning developmentally, and to help teachers capture what students have learned and can do with what they understand through real and relevant demonstration (Lambert, 2003). National standards for physical education were created by the National Association for Sport and Physical Education

(NASPE) in 1995 and revised in 2004. Although this national effort to develop standard-based curriculum have been made for more than a decade, physical education still has been left without a means to hold teachers and students accountable for learning (Rink et al., 2007). Schools, teachers, parents and students have few expectations for learning in physical education (Rink et al., 2007). The findings from this study may indicate that student motivation may not be a critical issue so long as the curriculum demands little for learning achievement.

Within a context of achieving, optimal learning occurs when students' needs for knowledge acquisition, motivation, and other desired outcomes of education are satisfied (Alexander, 2005). Possessing optimal motivation to learn is one of the most critical and important necessities for learners. From a social constructivist learning perspective, motivation should be "linked explicitly to ways of knowing, understanding, and constructing meaning" (Oldfather & Dahl, 1994, p.139). Research has shown that students in a social constructivist oriented physical education curriculum learned significantly better than did students in a multi-activity sport based curriculum (Sun et al., 2006). It seems plausible, therefore, that research on the motivational function of SDT on learning should be conducted in such a learning oriented curriculum environment to reveal findings with theoretical and practical meaning. Such investigations may help us find possible connections between learning and self-determined motivation to better inform curriculum development and offer motivation strategies for teachers to enhance student learning in physical education.

In summary, the findings of this study, seemingly disappointing, revealed a common phenomenon in physical education: the absence of connection between students'

motivation and learning. Results also showed that students did not lack motivation but they learned little regardless of their high motivation. The findings clearly demonstrated a strong need for curriculum reform. A learning-based, motivating curriculum is needed to reach the goal of physical education to help all students become physically educated.

Reference

- Alexander, P.A. (2005). *Psychology in learning and instruction*. Columbus, OH: Prentice-Hall.
- Bentler, P.M. (2006). *EQS structural equations modeling software* (Version 6.1) [Computer software] Encio, CA: Multivariate Software.
- Berlant, A.R., & Weiss, M.R. (1997). Goal orientation and the modeling process: An individual's focus on form and outcome. *Research Quarterly for Exercise and Sport*, 68, 317-330.
- Chen, A., & Ennis, C.D. (2004). Goal, interest, and learning in physical education. *The Journal of Educational Research*, 97, 329-338.
- Chen, A., & Shen, B. (2004). A web of achieving in physical education: Goals, interest, outside-school activity and learning. *Learning and Individual Difference*, 14, 169-182.
- Deci, E.L., Eghrari, H., Patrick, B.C., & Leone, D.R. (1994). Facilitating internalization: The self-determination theory perspective. *Journal of Personality*, 62, 119-142.
- Deci, E.L., Koestner, R., & Ryan, R.M. (1999). A meta-analytic review of experiments examining the effects of extrinsic rewards on intrinsic motivation. *Psychology Bulletin*, 125, 627-668.
- Deci, E.L., & Ryan, R.M. (1985). *Intrinsic motivation and self-determination in human behavior*. New York: Plenum.
- Deci, E.L., Vallerand, R.J., Pelletier, L.G., & Ryan, R.M. (1991). Motivation in education: The self-determination perspective. *The Educational Psychologist*, 26, 352-346.
- Gallahue, D.L. (1996). *Developmental Physical Education for Today's Children* (3rd

- Eds.). Times Mirrior Higher Education Group, Inc.
- Goodlad, J.I. (1984). *A place called school: Prospects for the future*. New York: McGraw-Hill.
- Gouda, M., & Biddle, S. (1994). Perceived motivational climate and intrinsic motivation in school physical education classes. *European Journal of Psychology of Education, 9*, 241-250.
- Hancock, G.R., & Mueller, R.O (Eds.). (2006). *Structural equation modeling: A second course*. Greenwich, CT: Information Age Publishing, Inc.
- Hu, L., & Bentler, P.M. (1999). Cutoff criteria fro fit indexes in covariance structure analysis: Conventional criteria versus new alternatives. *Structural Equation Modeling, 6*, 1-55.
- Lambert (2003). Standard-based program design: Creating a congruent guide for student learning. In S.J. Silverman and C.D. Ennis (Ed.), *Student learning in physical education* (pp. 147-163). Champaign, IL: Human Kinetics.
- Lockhart, A., & McPherson, F.A. (1949). The development of a test of badminton playing ability. *Research Quarterly, 20*, 402-405.
- Ntoumanis, N. (2001). A self-determination approach to the understanding of motivation in physical education. *British Journal of Educational Psychology, 71*, 225-242.
- Ntoumans, N. (2005). A prospective study of participation in optional school physical education using a self-determination theory framework. *Journal of Educational Psychology, 97*, 444-453.
- Oldfather, P., & Dahl, K. (1994). Toward a social constructivist reconceptualization of intrinsic motivation for literacy learning. *JRB: A journal of Literacy, 28*, 129-158.

- Pintrich, P.R. (2003). A motivational science perspective on the role of student motivation in learning and teaching contexts. *Journal of Educational Psychology*, 95, 667-686.
- Rink, J.E. (2001). Investigating the assumptions of pedagogy. *Journal of Teaching in Physical Education*, 20, 112-128.
- Rink, J.E., Jones, L., Kirby, K., Mitchell, M., & Doutis, P. (2007). Teacher perceptions of a physical education statewide assessment program. *Research Quarter for Exercise and Sport*, 78, 204-215.
- Ryan, R.M. & Connell, J.P. (1989). Perceived locus of causality and internalization: Examining reasons for acting in two domains. *Journal of Personality and Social Psychology*, 57, 749-761.
- Ryan, R.M., & Deci, E.L. (2000a). Self-determination theory and the facilitation of intrinsic, social development, and well-being. *American Psychologist*, 55 (1), 68-78.
- Ryan, R.M. & Deci, E. (2000b). Intrinsic and extrinsic motivation: Classic definitions and new directions. *Contemporary Educational Psychology*, 25, 54-67.
- Ryan, R.M., & Deci, E.L. (2000c). When rewards compete with nature: The undermining of intrinsic motivation and self-regulation. In C. Sansone & J.M. Harackiewicz (Eds.), *Intrinsic and Extrinsic Motivation: The search for optimal motivation and performance* (pp. 14-56), San Diego, CA: Academic Press.
- Shen, B., Chen, A., Scrabis, K.A., & Tolley, H. (2003). Gender and interest-based motivation in learning dance. *Journal of Teaching in Physical Education*, 22, 396-410.

- Siedntop, D., Doutis, P., Tsangaridou, S., Ward, P., & Rauschenbach, J. (1994). Don't sweat gym! An analysis of curriculum and instruction. *Journal of Teaching in Physical Education, 13*, 375-394.
- Solmon, M.A., & Boone, J. (1993). The impact of student goal orientation in physical education classes. *Research Quarterly for Exercise and Sport, 64*, 418-424.
- Standage, M., Duda, J.L., & Ntoumanis, N. (2003). A model of contextual motivation in physical education: Using constructs from self-determination and achievement goal theories to predict physical activity intentions. *Journal of Education Psychology, 95*, 97-110.
- Standage, M., Duda, J.L., & Ntoumanis, N. (2005). A test of self-determination theory in school physical education. *British Journal of Educational Psychology, 75*, 411-433.
- Sun, H., Chen, A., Ennis, C., Kim, S., Bonello, M., Hopple, C., & Bae, M. (2006). Curriculum matters: Situational interest and learning in elementary school physical education. *Research Quarterly for Exercise and Sport, 77 (1) Supplement*, 70.
- Wigfield, A., Lutz, S.L., & Wagner, A.L. (2005). Early adolescents' development across the middle school years: Implication for school counselors. *Professional School Counseling, 9(2)*, 112-119.
- William, G.C., & Deci, E.L. (1996). Internalization of biopsychosocial values by medical students. *Journal of Personality and Social Psychology, 70*, 767-779.
- Zhu, W., Safrit, M., & Cohen, A. (1999). *Fit Smart: The national health-related physical fitness knowledge test*. Champaign, IL: Human Kinetics.

Table 1. Means, Standard Deviations, and Cronbach's Alphas for All Subscales

	Mean	SD	Alpha
Intrinsic motivation	5.66	1.36	.90
Identified regulation	5.68	1.28	.83
Introjected regulation	4.30	1.47	.76
External regulation	4.14	1.64	.80
Amotivation	2.53	1.54	.83
Basketball pre-test	22.91	10.41	
Basketball post-test	23.97	7.22	
Residual-gain-score-basketball	-.0244	5.36	
Badminton pre-test	16.26	13.65	
Badminton post-test	23.19	16.14	
Residual-gain-score-badminton	.0264	13.71	
Knowledge pre-test	5.56	2.02	
Knowledge post-test	6.08	2.56	
Residual-gain-score-knowledge	.0094	2.46	

Table 2. *Results of Paired t-test*

	<i>t</i>	<i>p</i>	<i>Effect size</i>
Basketball pre-post	-1.87	.063	-.12
Badminton pre-post	-6.48	.001*	.46
Knowledge pre-post	-2.391	.018*	.23

Table 3. *Correlations among Self-determined Regulations*

	1	2	3	4	5
1. Intrinsic motivation		.898*	.255*	-.126	-.283*
2. Identified regulation			.307*	-.128	-.242*
3. Introjected regulation				.560*	.246*
4. External regulation					.443*
5. Amotivation					

* $p < .05$

Figures Caption

Figure 1. The Hypothesized Model

Figure 2. Lockhart-McPherson Badminton Test Setup

Figure 3. Court Markings for the AAHPERD Basketball Control Dribble Test (From AAHPERD, 1984)

Figure 4. SEM results for Hypothesized Paths

Figure 1. The hypothesized model.

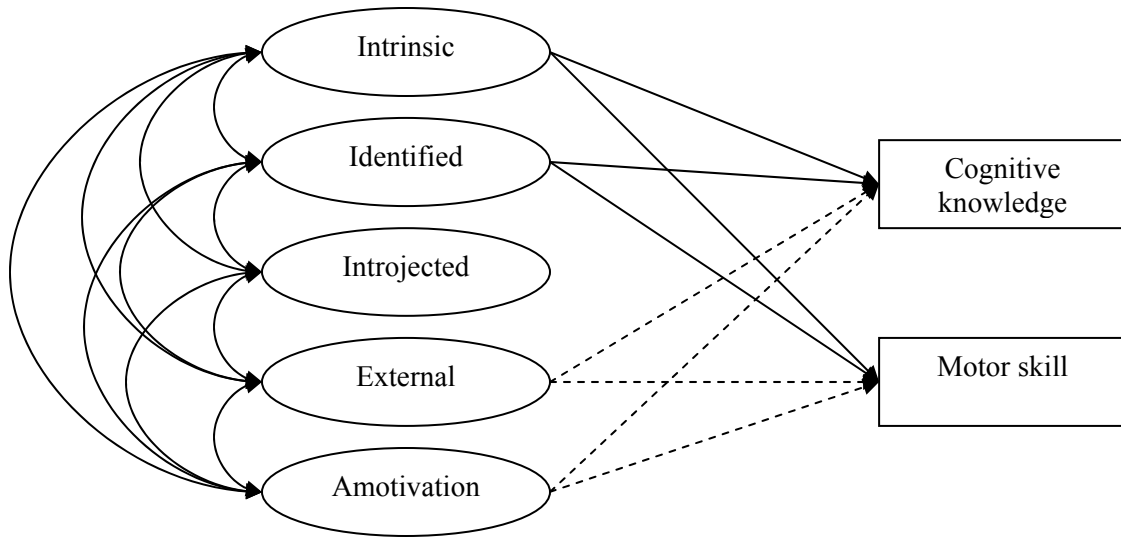

Note: Solid lines indicate positive relationships; broken lines represent negative relationships.

Figure 2. Lockhart-McPherson badminton test setup.

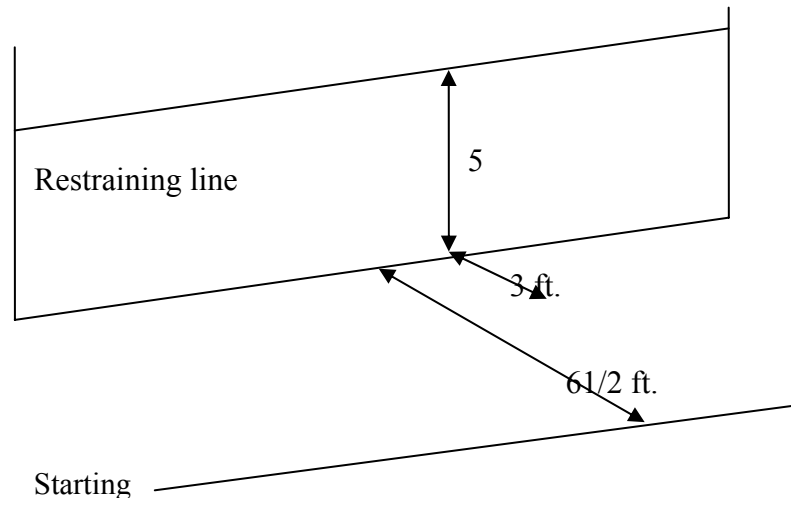

Figure 3. Court markings for the AAHPERD basketball control dribble test (from AAHPERD, 1984).

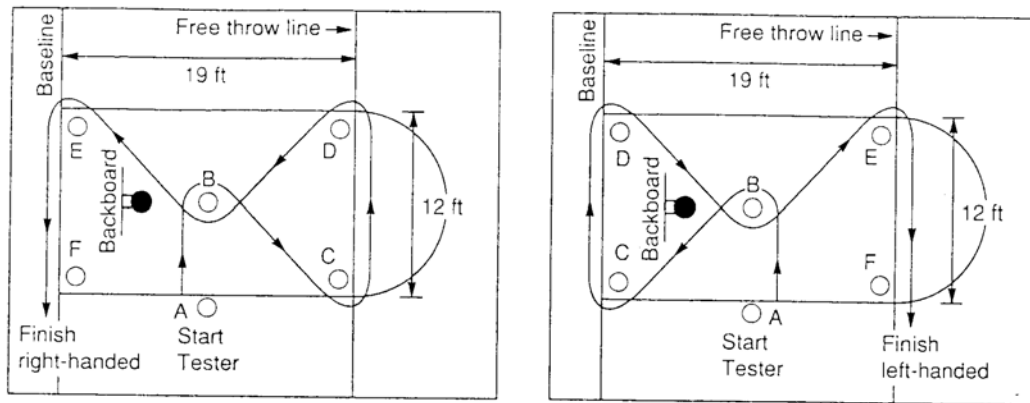
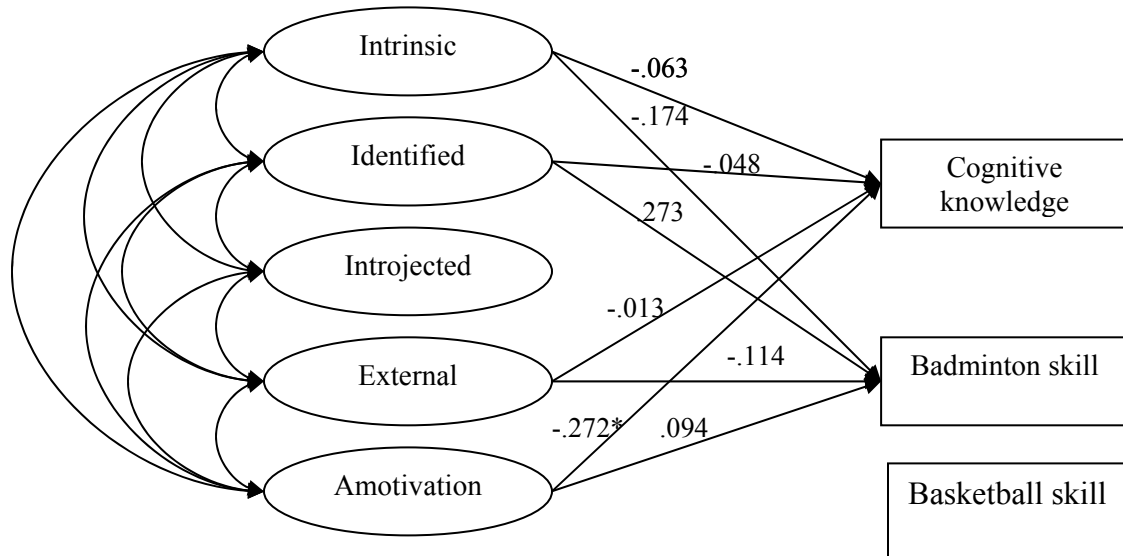

Figure 4. SEM results for hypothesized paths.



* $p < .05$

Conclusions and Recommendations

Conclusions

Guided by self-determination theory, the dissertation study has accomplished the two major purposes it was designed for: (a) examining the inter-relationships of the components in the self-regulation model to verify its tenability in motivating middle school learners in physical education, and (b) identifying the contribution of the self-regulated motivations to knowledge and skill learning in physical education. Based on the data structure, two separate analyses were conducted for answering the research questions: (a) Study 1: To what extent did students' satisfaction of the innate needs for autonomy, competence, and relatedness contribute to their self-regulated motivational processes? (b) Study 2: How critically does each self-regulation process function to contribute to or impede cognitive knowledge growth and motor skill improvement?

Results from the first study affirm the relative importance of satisfying students' innate needs in terms of their self-regulated motivation. An important finding from the analysis is that the impact of the need satisfaction varies, which is somewhat inconsistent with findings reported elsewhere (e.g., Ntoumanis, 2001). For example, satisfying autonomy and competence needs contributed largely to intrinsic motivation and identified regulation. But satisfying the autonomy need may not necessarily reduce the feeling of being externally regulated, implying that the students might enjoy autonomy in their physical education classes, but might be aware that the teacher was controlling the class and their behavior. Unexpectedly, satisfying the relatedness need was found to lead to student amotivation. It can be speculated that to the students the relatedness in physical

education might mean socializing with peers and friends. These socializing events might not be those that students need to motivate each other for learning.

In the second study a new SDT model with specific learning achievements built in was tested. Results indicated that, based on their self-report, students were relatively highly motivated. Amotivation was found to be low. However, the motivation did not seem to contribute significantly to learning achievement. Not surprisingly, amotivation was found detrimental to cognitive knowledge learning. A careful examination of the data led to the finding that the students did not achieve significantly during the study period. For one skill showing the largest magnitude of improvement, the improved achievement was still below the minimum standard for skillfulness. The examination led to a conclusion that the absence of connection between the SDT components and learning achievement may be due to the absence of achievement.

Taken together, the findings suggest that the self-regulated motivations are likely to function in physical education as they were observed in studies in classrooms and other physical education settings. The SEM model supports the motivational function of satisfying students' innate needs for autonomy, competence, and relatedness. The role of satisfied needs in the motivation process, however, can be complicated, especially the role of satisfying the relatedness need. It seems that the need must be satisfied on the basis of learning-oriented activities rather than merely socializing to avoid the likelihood of leading students to amotivation. The contribution of the self-regulated motivations to learning achievement needs to be further examined. Based on the current data, the contributions are insignificant. The findings reiterate the concern about achievement motivation in physical education. That is, we should not assume that physical education

settings are learning-achievement oriented; or that our students are aware the achievement demand in physical education. Contributions of learner motivation to learning achievement will be better examined when learning achievement is emphasized in the physical education curriculum.

Implications/Recommendations

Theoretical revision. The results of the two studies may suggest that physical education is different from classroom settings. To apply a theoretical model to the physical education domain, the function of the model in this domain needs to be carefully examined first. Without understanding the fundamental function, the implementation of the theoretical model may not be able to achieve the expected outcomes. For instance, if SDT model is applied to physical education setting merely based on the theoretical assumptions and research findings in other domains, fostering students' need for relatedness may not lead to a more self-determined motivation. Because encouraging peer interactions *without* emphasizing learning tasks may have a detrimental impact on learner motivation and keep them from participating in class activities. The findings remind researchers and educators that cautions need to be taken when we attempt to implement a theoretical model in physical education. Theories or models cannot be adopted without experimental exploration. Necessary theoretical revisions are also needed to better fit the domain of physical education.

Future research. The findings suggest that more studies are needed to further examine the functions of SDT model in physical education settings. First, it is critical to understand the complex role of student need for relatedness in the motivational and learning processes. Although students' social interaction and cooperative learning are

considered to be important instructional strategies to help them learn, peer relationships and the sense of belongingness are also acknowledged to be important factors in students' socialization process. Better understanding of these issues may help physical educators better structure in-class social interaction experiences to facilitate students' optimal learning. In addition to peer interaction, studies are also needed to investigate how teacher and student interactions facilitate students' need for relatedness and how such need satisfaction will impact their motivational process as well as other motivational consequences. Second, curriculum intervention studies aimed to enhance student learning in physical education are needed. Although learning-based physical education has been advocated for many years, such curricula rarely have been examined empirically in practice. Third, students' need satisfaction and motivational processes need to be explored in a learning-based physical education curriculum in order for us to find the actual impact that motivation constructs may have on student learning.

Implications for curriculum and instruction. The findings of these two studies have significant pedagogical implications. In practice, teachers should treat students as the center of learning and organize opportunities for students to take initiative in their learning process in order to facilitate their need for autonomy. Teachers also need to provide students with instructional structures involving effective communication of realistic expectations, consistent criteria, and competence-based feedback and create a climate to promote students' personal responsibility and self-confidence; and students' need for competence, thus, can be fulfilled (Standage, Duda, & Ntoumanis, 2003). With the satisfaction of autonomy and competence needs, students are more likely to be intrinsic or identified motivated. Moreover, when teachers encourage peer interaction and

cooperative learning, they need to understand the nature of students need for relatedness and plan and organize in-class peer interactions centering on learning.

The results clearly demonstrated the need for developing learning-based physical education curriculum to help student achieve and enhance their learning. In addition, curriculum developers need to explore how motivational elements can be implemented in such a learning oriented curriculum environment to make students' learning experience enjoyable and interesting. In recent years, physical education researchers have advocated using social constructivism as an alternative theoretical perspective on student learning to reform school physical education (Ennis, 2000, 2003; Kirk & Macdonald, 1998; Rovegno & Kirk, 1995). A social constructivist learning orientated physical education curriculum has been found to have significant positive impact on student cognitive knowledge learning (Sun et al., 2006). This dissertation provided a strong basis for future studies using a joint theoretical perspective of SDT and social constructivism of learning because both theoretical perspectives share a common belief that students' self determination is the driving force of meaningful learning. Such investigation may help us find the possible connection between social constructivist learning and self-determination of motivation in curriculum development and offer strategies that teachers can use to enhance student learning in physical education.

APPENDIX A

INTRODUCTION

An important goal of physical education is for students to develop a healthy, physically active lifestyle (National Association for Sport & Physical Education, [NASPE], 2004). In order to achieve this goal, students in physical education are expected to learn the knowledge, benefits, and principles of physical activity and motor skills that are necessary for them to take part in physical activities, exercises, and a variety of sports and games in their daily life (Corbin, 2002). Students' learning, therefore, is the most important mission of physical education.

Learning in physical education has been defined as a relatively permanent behavioral change resulting from experiencing physical movement along with enhancement of the cognitive understanding of the movement (Rink, 2001). It is argued (Lambert, 2003) that true learning in physical education can only occur when students become able to use knowledge, skill, and practices in applied settings in real life. Learning, therefore, can be understood as students' mastery of the knowledge and skills meaningful to their lives. In the recent decade, the social constructivist learning perspective has been acknowledged by physical education researchers as one of the most effective approaches that enhance meaningful learning. Research in physical education has shown a connection between a learning environment that emphasizes students' social interaction and the enhancement of meaningful learning (Azzarito & Ennis, 2003; Cothran & Ennis, 1999; Ennis, 1999, 2000).

A critical factor that often determines success and failure in learning is learner motivation (Pintrich, 2003). Alexander (2005) articulated that the very first step for

educators to take is to understand the nature of learner motivation in order to foster a positive motivation experience for learners. Without this understanding, Alexander (2005) further argued, it will be very difficult for educators to engage students in learning and achieve learning goals. In physical education, Chen and Ennis (2004) also suggested that it would be difficult for physical education teachers to encourage students to develop healthy, physically active life without appropriate motivation strategies. The general purpose of this study is to examine the relationship between an important motivation construct (self-determination) and learning in middle school physical education. I believe that the study will help us understand students' motivation development in relation to their adoption of different behavioral regulation strategies that lead to learning achievement.

Theoretical Framework

The study is guided by the framework of Self-Determination Theory (SDT) in motivation research (Deci & Ryan, 1985, 2000). The development of the framework coincided with many other theoretical frameworks of motivation, mainly the achievement goal theory (Dweck & Leggett, 1988; Nicholls, 1984), expectancy-task value theory (Eccles, Adler, Futterman, Goff, Kaczala, Meece, & Midgley, 1983), interest-based motivation theory (Krapp, Hidi, & Renninger, 1992), and self-efficacy theory (Bandura, 1986). With the exception of SDT, these theories have received tremendous attention from physical education researchers (see Chapter 2 for a thorough review) and been studied extensively. Until most recently, in most research studies, learner motivation had been conceptualized as mental dispositions. For example, in the achievement goal research, it was not until the late 1990s that researchers focused on achievement goal

climates. Similarly, in the interest-based motivation research, the concept of situational interest also was not thoroughly articulated until 1990s.

In SDT learner motivation has been conceptualized as a process regulated by both learner innate needs and social influences of the learning environment. This conceptualization is consistent with the theory of social constructivist learning which is acknowledged as the fundamental assumption for the current study. For this study, it is assumed that for any achievement occurring in physical education, learning is acquired through the individual learner's construction of information, knowledge, and skills under the influence of his/her particular learning environment and life in and outside of physical education. In this chapter, I will briefly discuss the social constructivist learning theory, major motivation constructs, and SDT to arrive at the specific purposes and significance of the study, research questions, and research hypotheses.

The Basic Assumption: Social Constructivist Learning

Social constructivism asserts that knowledge cannot be simply received and stored; instead it is actively constructed by individuals in a specific socio-cultural environment. The social constructivism claims that "learning is a necessary and universal aspect of the process of developing culturally organized, specifically human psychological function" (Vygotsky, 1978, p. 90). Accordingly, learning occurs when the learner internalizes knowledge and skill with the social experiences of interacting with others during the knowledge construction processes. The theory also emphasizes, in particular, the importance of the learner's interaction with knowledgeable, experienced others in the learning process and the reciprocity of the social-interaction between the knowledgeable others and the learner (Oldfather & Dahl, 1994). In short, the theory

reiterates a belief that knowledge and learning cannot exist without human beings' construction (Alexander, 2005) and the process of knowledge construction is highly social-interactive (Oldfather & Dahl, 1994).

Researchers in physical education have acknowledged that knowledge and motor skill learning share these characteristics of social constructivist learning. Azzarito and Ennis (2003) summarized that the ultimate goal of physical education is to provide students with educational experiences that are authentic and meaningful to them. In such a learning context, teachers are facilitators who design group works for students to encourage social interaction and collaborative learning. Azzarito and Ennis (2003) designed learning tasks that enhance the authenticity of learning by relating the content that students are learning to their previous experiences, prior knowledge, and existing skills. In these environments, students are viewed as active learners and decision makers who take initiative, think carefully about the purpose of learning, and take ownership of what they learn (Azzarito & Ennis, 2003). In this type of learning environment, learners' autonomy is enhanced and, in turn, they become more willing to engage in the learning process. In other words, they are more likely to become motivated in this type of learning environment.

Motivation Constructs

Motivation is the process that energizes behavior and gives the behavior direction (Deci & Ryan, 1985). Lack of motivation is one of the most serious concerns in educational setting with respect to students' learning (Alexander, 2005). Motivation energizes and directs human beings' behaviors toward specific outcomes (Deci & Ryan, 2000). In education, motivation is often manifested in student learning behaviors and is

characterized by their choice of learning tasks, persistence on practice, the vigor of effort in carrying out assignments, and demonstration of achievement (Wigfield & Eccles, 2002). Pintrich and Schunk (2002) argued that highly motivated individuals engage in tasks or activities with high energy, correct direction, and full commitment.

Research on motivation in education has focused on students' achievement-related goals, needs, values, beliefs, and interest. These motivation constructs delineate in detail the characteristics of motivation sources derived from students' achievement goal orientations (Nicholls, 1984), beliefs of success and conception of task values (Eccles et al., 1983), interest in the content (Renninger, Hidi, & Krapp, 1992), and need satisfaction for autonomy, competence, and relatedness (Deci & Ryan, 1985; Ryan & Deci, 2000a). Thus, the research on these constructs has afforded the field different motivation theories, several of which I will discuss briefly below and provide detailed discussions in Chapter two.

Goal theory. Goal theory has been a major focus of research on students' motivation. There are two content goals that students pursue in the schools setting, academic and social goals. Within academic goals, research has differentiated four primary types of goal orientations that students might have, including mastery-approach, mastery-avoidance, performance-approach, and performance-avoidance. Social goals that students pursue in school have been classified as prosocial goals (to help, cooperate, and share with peers and teachers) and social responsibility goals (to keep interpersonal commitment and promises and follow the rules) (Wentzel, 2002). Understanding the content and orientations of the goals that students pursue in the classroom has been a dominant focus in motivation research in the past quarter century. These research

outcomes have been encouraging in that learner goals have been found to predict of learner academic achievement in classrooms (Anderman, Austin, & Johnson, 2002). The research in physical education, however, has not provided conclusive evidence on the relationship between the nature of goals and student learning behavior and outcomes. For example, the findings from the few studies that actually measured students' learning behaviors and learning outcomes (e.g., Berlant & Weiss, 1997; Chen & Shen, 2004; Solmon & Boone, 1993) suggest a rather weak association between the mastery/task goal orientation and students' adaptive learning behaviors and achievements.

Expectancy-value theory. Expectancy-value theory posits that students' expectancies for success on achievement tasks and the subjective value they attach to success on these achievement tasks will directly predict their choice, persistence, and performance of these tasks (Wigfield & Eccles, 2002). Students' expectancies and values are predicted by their achievement beliefs derived from their conceptions of self-competence and task difficulty. In addition, students' achievement beliefs are influenced by their interpretations of their past performance and their perception of their parents or teachers' attitudes and expectations (Wigfield & Eccles, 2002). The theory implies that learner motivation relies on individual beliefs developed in particular social learning environment.

The expectancy-value theory consists of two integral parts: expectancy beliefs and perceived task values. Expectancy beliefs refer to children's beliefs about how well they will do on an upcoming task (Eccles et al., 1983). Task values include four distinct components often identified by the learner in learning task: attainment value or importance, intrinsic value or interest, utility value, and cost (Eccles et al. 1983).

Classroom-based research has revealed that task values are predictive of choice decisions and future engagement whereas expectancy beliefs predict achievement after individuals actually engage in a given activity (e.g., Eccles, Wigfield, & Schiefele, 1998; Wigfield & Eccles, 2002). In physical education, research has shown that expectancy beliefs predict effort and persistence (Cox & Whaley, 2004; Xiang, McBride, & Bruene, 2006) and students' performance (Xiang, McBride, & Bruene, 2004). Task values, interest value in particular, are strong predictors of students' intentions for future participation in physical activities (Xiang et al., 2004).

Interest-based theory. Interest has been conceptualized as individual/personal and situational (Krapp, Hidi, & Renninger, 1992). Individual interest refers to a person's psychological disposition or preference for an activity or action. Individual interest is a relatively stable and enduring disposition (Krapp et al., 1992). Situational interest, on the other hand, is defined as a psychological state that is elicited by certain aspects of the immediate environment, such as the way learning tasks are organized and presented (Krapp et al., 1992). Research on both individual and situational interest has shown that students with a high level of either type of interest can demonstrate a high level of cognitive engagement, increased motivation to learn, and enhanced achievement (Pintrich, 2003). In addition, Alexander, Jetto and Kulikowich (1995) found that the students with high domain knowledge are likely to demonstrate higher individual interest in the domain and perform better in free-recall knowledge tests than those with low knowledge. In physical education, students' individual interest was not found to be directly related to learning outcomes (Chen & Shen, 2004). However, research did reveal that both

individual interest and situational interest were related to students' use of learning strategies (Shen & Chen, 2006).

Self-determination Theory

The research on students' goals, values, beliefs, and interest has been conducted to answer the question of what motivates students in classrooms in relation to the social-cognitive influences (Pintrich, 2003). Studying these motivational constructs, as Pintrich (2003) noted, may not allow us to answer the question of what students want and to identify their possible basic needs that define what they want. The uniqueness of SDT, as one of the most important motivational perspectives, is its integrated approach to studying the simultaneous relationship of basic human needs and social-cognitive influences.

Human needs. SDT postulates that all human beings have basic psychological needs that serve as the cornerstones of human motivation. These needs include the needs for competence, autonomy, and relatedness. Specifically in SDT, *Competence* refers to feeling effective in one's ongoing activities. The more competent a person perceives him/herself in an activity; the more intrinsically motivated one will be at that activity (Deci & Ryan, 1985). Research in physical education also indicates that students with higher levels of perceived competence are more likely to be active in their physical education classes (Parish & Treasure, 2003). *Autonomy* is the degree to which an individual perceives her/himself as the origin or source of a behavior and as being responsible for the initiation of the behavior (Ryan & Deci, 2002a). When experiencing autonomy, an individual regulates his/her own behavior by governing the energy and direction of actions (Ryan & Powlson, 1991). Research in physical education has shown

that students' perceived autonomy predicts their self-determined motivation (Hagger, Chatzisarantis, Culverhouse, & Biddle, 2003; Hagger, Chatzisarantis, Barkoukis, & Wang, 2005; Standage, Duda, and Ntoumanis, 2003a). *Relatedness* is defined as the extent to which an individual feels connected to others and their sense of belongingness both with one's community and with other individuals. To date, a weak, but positive, correlation has been documented between students' satisfaction relatedness and higher levels of self-determination in physical education (Ntoumanis, 2001).

SDT holds that satisfaction of all three needs is critical for self-determined motivation and adaptive consequences. It assumes that the degree to which the individual perceives need satisfaction will be represented by different types of motivation (Ryan & Deci, 2000a). When these basic needs are satisfied, self-determined motivation is more likely to be generated. When these needs are thwarted, intrinsic motivation diminishes and maladaptive consequences can occur. SDT findings in physical education, especially those with achievement goal climate variables (e.g., Standage et al., 2003a), seem to support a constructivist approach to curriculum and instruction. Nevertheless, research findings in physical education are still limited in guiding the development of a motivating curriculum through providing a holistic framework in which each need can function to make unique contribution to learner motivation. It is important, then, to clarify the individual contribution of each innate need so that teachers can create a constructivist learning environment conducive to optimal learner motivation and achievement.

The self-regulation continuum. Deci and Ryan (e.g., 1985, 2000) conceptualized SDT as a motivation process in which an individual self-regulates his/her action mediated by her/his perceived needs satisfaction in a social environment. This process is

characterized by six major components whose motivational functions vary in terms of individuals' need satisfaction and person-environment interaction as well as the outcome of the interaction. A self-regulation continuum proposed in SDT, described in Figure 1.1, identifies different types of motivation based on the way a learner regulates the learning behavior. *Amotivation* is at the far left side and *intrinsic motivation* is at the far right side of the continuum to contrast the state of motivation. *External regulation*, *introjected regulation*, *identified regulation*, and *integrated regulation* are positioned between amotivation and intrinsic motivation to indicate the type of motivation based on its self-regulation style.

The most desirable self-determined motivation is intrinsic motivation. An intrinsically motivated individual engages in activity for the activity itself without the necessity of material rewards or constraints (Deci, Vallerand, Pelletier, & Ryan, 1991). In physical education, research has shown that students who are intrinsically motivated are more likely to demonstrate adaptive behaviors, such as high concentration level (Ntoumanis, 2005; Standage, et al., 2005), preference to attempt challenging tasks, and demonstration of positive affect (i.e., happy, satisfied, excited, and relaxed) (Standage, et al., 2005).

Within *extrinsic motivation*, there are four different levels of regulations. *External regulation* is the least self-determined motivation. Externally regulated individual participates in an activity usual with an expectation to receive reward or to avoid punishment. Theoretically, external regulation would lead to maladaptive affective and/or cognitive consequences (Deci & Ryan, 1985). However, no relationship, positive or negative, has been found between external regulation and affective or cognitive

consequences in physical activity (Ntoumanis, 2001). *Introjected regulation* refers to partial or suboptimal internalization of external values and/or expected behaviors with which the individual has not yet fully identified and accepted as his/her own. (Deci, Eghrari, Patrick, & Leone, 1994). Current research suggested that introjected regulation did not predict any motivational, affective, or behavioral outcome in physical education (Ntoumanis, 2001; Standage et al., 2003a, Standage et al., 2005).

Identified regulation is a more self-determined form of extrinsic motivation. The individual has become identified with the external values and expected behaviors and has accepted the values and behaviors as personally needed. Identified regulation reflects the fact that the individual is able to consciously regulate his/her motivation to guide the behavior (Ryan & Deci, 2000c). Research in physical education has not found identified regulation predictive of any adaptive or maladaptive outcomes (Ntoumanis, 2001). The last type of regulation, *integrated regulation* is the most self-determined form of extrinsic motivation. It occurs when the individual assimilates identified regulation and brings it into congruence with his/her other values (Ryan & Deci, 2000c). Ryan and Connell (1989) argued that elementary and middle school students are too young to have achieved a sense of integration with respect to school academic activities. To date, few studies have examined integrated regulation in both classroom-based education and physical education.

Figure 1.1 A continuum of self-determination (adopted from Ryan & Deci, 2000a)

	Nonselself-determined ←————→ Self-determined					
	<i>Amotivation</i>		<i>Extrinsic motivation</i>			<i>Intrinsic motivation</i>
<i>Regulatory Styles</i>	Non-regulation	External regulation	Introjected regulation	Identified regulation	Integrated regulation	Intrinsic motivation
<i>Perceived locus of causality</i>	Impersonal	External	Somewhat external	Somewhat internal	Internal	Internal
<i>Relevant regulatory processes</i>	Non-intentional, non-valuing, incompetent and lack of control	Compliance, external rewards and punishment	Self-control, ego-involvement, internal rewards and punishments	Personal importance and conscious valuing	Congruence, awareness, synthesis with self	Interest, enjoyment, inherent satisfaction

Amotivation is characterized by individuals' lack of intent and effort when engaged in an activity (Ryan & Decia, 2000). It often takes place when the individual feels incompetent to succeed in the activity or perceives little value in succeeding. Research in physical education settings has revealed that amotivation leads to maladaptive consequences, such as boredom (Ntoumanis, 2001) or lack of intention to participate in after-school physical activities (Standage et al., 2003b).

Research on self-determined motivation and on external conditioning of intrinsic motivation has provided strong support to the notion that in a social environment such as schools, classrooms, and gymnasias, intrinsic motivation will be influenced by social factors. Research findings reveal that positive or negative feedback from teachers, peer students, or parents, stickers for participation in an activity, and award certificates for successful performances can all have external regulatory impact on intrinsic motivation, one way or the other. Thus, it has become extremely important to understand the process of regulations and their impact on learner self-determined/regulated motivation.

Hierarchical model of self-regulated motivation. Based on the continuum, Vallerand and colleagues (Vallerand & Losier, 1997; Vallerand & Rousseau, 2001) proposed a hierarchical self-regulation model of motivation. This model is operationalized by a motivation sequence of “social factors —> need satisfaction —> types of motivation —> consequences.” Figure 1.2 displays this hierarchical motivation model. This model postulates that the degree to which a social environment supports autonomy, competence, and relatedness will influence the level of individuals' three innate needs satisfactions. These, in turn, will lead to different types of motivation as well as the consequences associated with each motivation types. The model also

indicates that at each sequence cluster, an individual's motivation will depend on a set of specific components, such as types of social support, a specific need satisfied, a specific regulation process adopted, and a specific outcome expected.

Figure 1.2 The hierarchical self-regulation model of motivation (adapted from Vallerand & Losier, 1999)

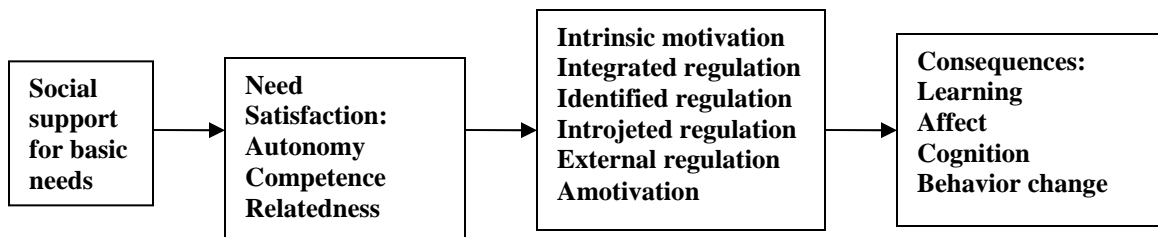

The Rationale for the Study

Based on the social constructivist perspective, learning is a social, collaborative activity where the learner is actively engaged in social interaction with knowledgeable and experienced others, such as the teacher or peers. In such an environment, the role of the teacher is to guide and facilitate the constructive social interactions that enhance learning rather than merely to control students who go through the activity in an amotivated state. An important assumption in constructivist learning theory is that the learner is not a plane slate or a passive knowledge recipient. Rather the learner is actively processing knowledge and skills being learned in terms of his/her existing knowledge and skill, perceived value of the content, and the achievement goals he/she is able to identify and integrate.

During this knowledge and skill acquisition process, the learner needs to develop and maintain a high level of motivation to be successful, and, more importantly, to be able to achieve self-regulation that allows him/her to actively reflect on prior experiences

and make connection between the new and existing knowledge and skills. Although other motivation theories have informed us of various possibilities to enhance learner motivation, SDT is a unique theoretical framework that stresses the importance of following a journey of regulations to lead the learner to intrinsic motivation. That is, from an amotivation state, through externally regulated extrinsic motivation, to the ultimate goal: intrinsic motivation.

From previous studies, it is clear that an overall satisfaction of the three innate needs may lead to self-determined motivation in physical education. However, the independent contribution of satisfying each individual need for motivation is not clearly articulated in physical education. It is important, then, to clarify the individual contribution of satisfying each innate need for teachers to create a constructivist learning environment conducive to optimal learner motivation and achievement. Moreover, we know that students' self-regulated motivation can predict their affection, effort, concentration, and intention toward after school physical education. It is not clear, however, how students' self-regulated motivation will lead to their knowledge and skill learning.

Through the above discussion, it is clear that SDT has potential to provide a sound theoretical basis on which a series of motivation strategies can be developed for creating a positive social-constructivist learning environment in physical education. This study is intended to examine this potential by carefully verifying the hierarchical pattern of relationships observed in the theoretical model identified in previous studies. More importantly, this study will extend the research on SDT to investigate its actual impact on students' learning achievement, a phenomenon that has rarely been examined in previous

research in physical education. It is hoped that the results will provide useful information about the relationship between self-regulated motivations and learning achievement that will guide effective development of learning-enhancing motivation strategies in the future.

This study was conducted in 6th grade because of the uniqueness of 6th graders in their middle school years. Sixth grade students experience many changes, including biological changes and the social and educational changes related to the transition from elementary to middle school (Wigfield, Lutz, & Wanger, 2005). Beginning in the middle school, students' feeling of competence declines due to the intensifying social comparisons and the advent of competitive grading system (Convington & Dray, 2002). However, their need for competence to prove themselves via an ability status increases as they move from elementary school into middle school (Convington & Dray, 2002). Comparing to their elementary years, 6th graders start to display a stronger need for developing peer relationships and a sense of belongingness (Wentzel, 1999). Also, it has been reported that students perceive increased opportunities for autonomous decision making in the transition to middle school years (Convington & Dray, 2002).

Six grade students' development of motivation may also manifest a unique pattern. For example, Wigfield & Eccles (2002) suggested that students' valuing of school subjects often declines as they move through school, especially during the transition to middle school. In addition, research has shown that students of this age group have lower intrinsic motivation for learning and perceived competence than do their younger peers (Jacobs et al., 2002; Wigfield & Eccles, 2002). Wigfield and colleagues (Wigfield, et al., 2005) indicated that this can be a time period in which students' motivation declines significantly and thus, motivational problem can become more central during this time.

It has been argued that research on students' motivation and learning in the middle school transition period is inadequate (Convington & Dray, 2002). Further, how SDT model is manifested in 6th grade physical education is not clear. Therefore, understanding how students' need satisfaction and their self-regulated motivation may provide insightful information for developing appropriate motivational strategies to help student learning and achievement in their middle school transition.

Purpose of the Study

There are three specific purposes in this study: (a) to examine the inter-relationships of the components in the hierarchical self-regulation model to verify its tenability in motivating middle school learners in physical education, (b) to identify possible changes among the inter-relationships of the components in the model when learning achievement is included in the model, and (c) to identify the contribution of the regulated motivations to knowledge and skill learning in physical education.

To achieve the research purposes, the study is focused on answering the following research questions: (a) To what extent does students' satisfaction of the innate needs for autonomy, competence, and relatedness contribute to their intrinsic motivation and self-regulation processes? (b) How critically does each self-regulation process function to contribute to or impede cognitive knowledge growth and motor skill improvement? and (c) To what extent do the External Regulation and Amotivation detrimentally impact knowledge growth and motor skill improvement in physical education? It is hypothesized that the fulfillment of the three innate needs will directly lead to different types of motivation and indirectly influence (through motivation) students' learning in physical education. Further, that students' different types of self-regulated motivation will result in

different learning outcomes reflected their cognitive knowledge and motor skill learning in physical education. Specific research hypotheses are, as seen in Figure 1.3, (a) Students' satisfaction of the innate needs for autonomy, competence, and relatedness will contribute to students' intrinsic motivation, identified regulation, and introjected regulation and negatively predict their external regulation and amotivation, (b) Students' intrinsic motivation and identified regulation will contribute to cognitive knowledge growth and motor skill learning while; students' introjected regulation may not contribute to knowledge and motor skill learning, and (c) external regulation and amotivation may detrimentally impact knowledge and motor skill learning.

Figure 1.3 Hypothesized model of the study.

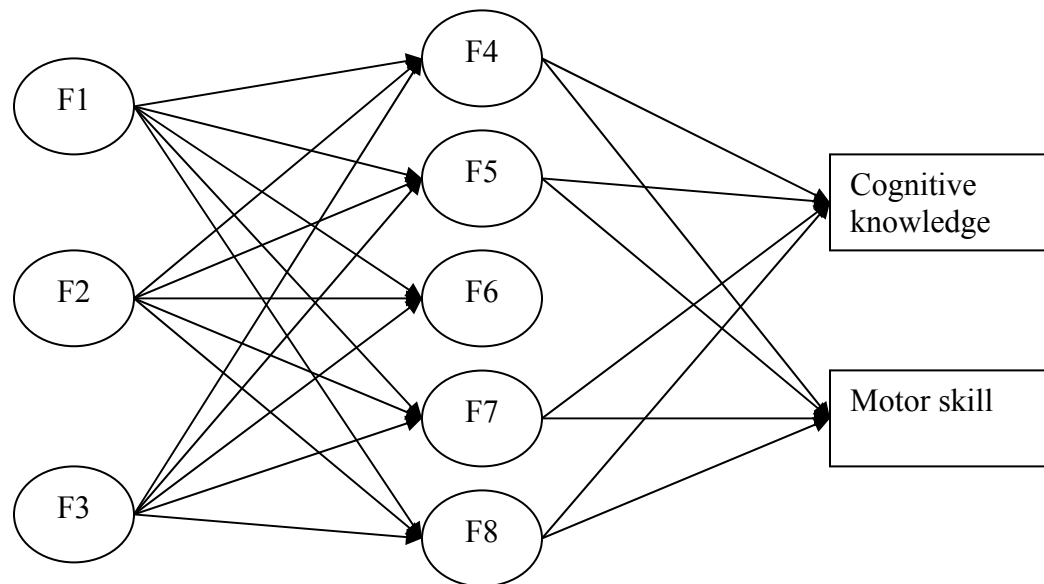

Note: F1= need satisfaction of autonomy; F2= need satisfaction of competence, F3= need satisfaction of relatedness, F4= intrinsic motivation, F5= identified regulation, F6= introjected regulation, F7= external regulation, F8= amotivation.

The hypothesized direct relations to be tested in the study are described in Figure 1.4 below:

Figure 1.4 The hypothesized relationships between need satisfaction and motivation (the hypothesized relationships are the same for the three needs).

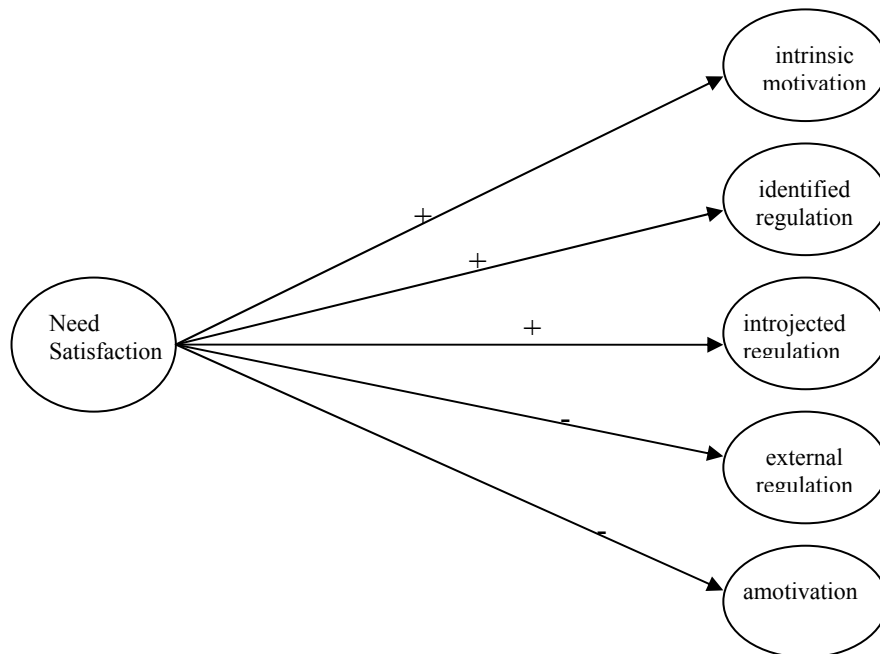

Autonomy need satisfaction (Hypothesis Block 1-H1):

H1a: A positive relation between autonomy need satisfaction and intrinsic motivation.

H1b: A positive relation between autonomy need satisfaction and identified regulation.

H1c: A positive relation between autonomy need satisfaction and introjected regulation.

H1d: A negative relation between autonomy need satisfaction and external regulation.

H1e: A negative relation between autonomy need satisfaction and amotivation.

Competence need satisfaction (Hypothesis Block 2-H2)::

H2a: A positive relation between competence need satisfaction and intrinsic motivation.

H2b: A positive relation between competence need satisfaction and identified regulation.

H2c: A positive relation between competence need satisfaction and introjected regulation.

H2d: A negative relation between competence need satisfaction and external regulation.

H2e: A negative relation between competence need satisfaction and amotivation.

Relatedness need satisfaction (Hypothesis Block 3-H3):

H3a: A positive relation between relatedness need satisfaction and intrinsic motivation.

H3b: A positive relation between relatedness need satisfaction and identified regulation.

H3c: A positive relation between relatedness need satisfaction and introjected regulation.

H3d: A negative relation between relatedness need satisfaction and external regulation.

H3e: A negative relation between relatedness need satisfaction and amotivation.

According to SDT, individuals' different types of motivation will result in different consequences/outcomes. In this study, it is hypothesized that there will be negative, positive, or no links between students' self-regulated motivation and learning outcomes of cognitive knowledge and motor skill. The followings are hypothesized direct relations to be tested in the study:

Intrinsic motivation (Hypothesis Block 4-H4):

Figure 1.5 The hypothesized relationships between intrinsic motivation and learning

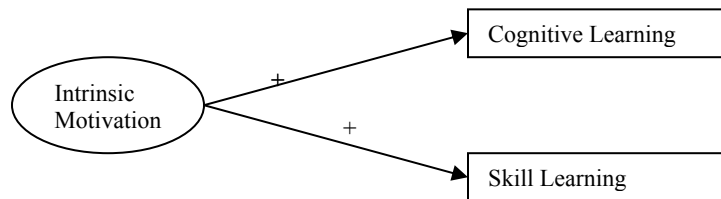

H4a: A positive relation between intrinsic motivation and cognitive learning in physical education.

H4b: A positive relation between intrinsic motivation and motor skill learning in physical education.

Identified regulation (Hypothesis Block 5-H5):

Figure 1.6 The hypothesized relationships between identified regulation and learning.

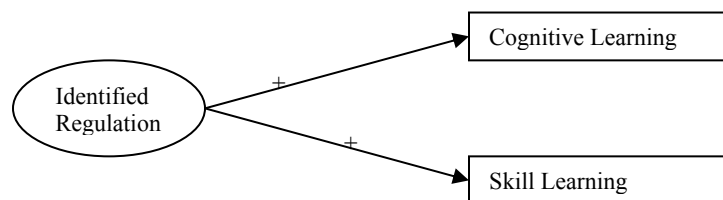

H5a: A positive relation between identified regulation and cognitive learning in physical education.

H5b: A positive relation between identified regulation and motor skill learning in physical education.

Introjected regulation (Hypothesis Block 6-H6):

H6a: No relation between introjected regulation and cognitive learning in physical education.

H6b: No relation between introjected regulation and motor skill learning in physical education.

External regulation (Hypothesis Block 7-H7):

Figure 1.7 The hypothesized relationships between external regulation and learning.

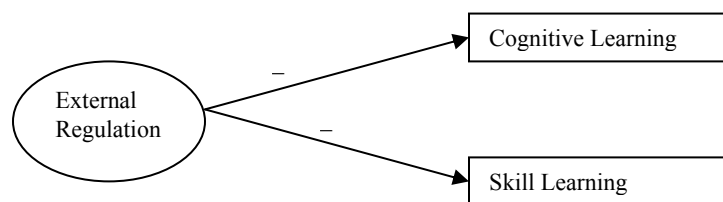

H7a: A negative relation between external regulation and cognitive learning in physical education.

H7b: A negative relation between external regulation and motor skill learning in physical education.

Amotivation (Hypothesis Block 8-H8):

H8a: A negative relation between amotivation and cognitive learning in physical education.

H8b: A negative relation between amotivation and motor skill learning in physical education.

Figure 1.8 The hypothesized relationships between amotivation and learning.

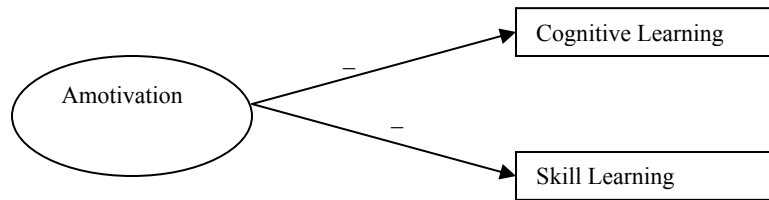

Significance of the Study

Cognitive learning and motor skill acquisition are two major learning goals for students in physical education. Nevertheless, in motivation research from either the social cognitive perspective or the human need perspective, knowledge and skill learning have seldom been measured as outcomes variables. Therefore, the extent to which various motivation strategies contribute to student learning remains unclear. For example, it was found in a recent study that although students can be motivated by situational interest, they learn little when the interesting material is unrelated to the content (Shen & Chen, 2006).

The importance of motivation in student learning has been broadly acknowledged. Student motivation has become one of the major concerns that educators and teachers express when attempting to promote optimal student learning. Although research on motivation in physical education has identified functions of achievement goals, expectancy-values, and interests in motivating students learning behaviors and achievements, the mechanisms underlying regulation of learning behaviors and their contribution to achievement remain unclear. In addition, research on these motivation constructs emphasizes motivation as deriving from external processes that the learner adapts to the external environments. Motivation, as an innate mental process, should also be considered as a drive residing within a person that is waiting to be called upon in situations where motivation is needed (Hidi & Harackiewicz, 2000). Therefore,

exploration of the self-regulated motivation model with student learning outcomes may facilitate an understanding of the interaction of students' innate needs, motivation, and learning in physical education.

In addition, this dissertation study will be conducted in middle schools and the results of this study may contribute to our understanding of the interaction between motivation and learning in middle schools students. Middle school students experience many changes, including biological changes and the social and educational changes related to the transition from elementary to middle school (Wigfield, Lutz, & Wanger, 2005). These changes, according to Wigfield and colleagues (Wigfield et al., 2005), may have a significant impact on students achievement motivation and academic achievement. Moreover, Wigfield & Eccles (2002) suggested that students' valuing of school subjects often declines as they move through school, especially during the transition to middle school. In addition, research has shown that students of this age group have lower intrinsic motivation for learning and perceived competence than do their younger peers (Jacobs et al., 2002; Wigfield & Eccles, 2002). Wigfield and colleagues (Wigfield, et al., 2005) indicated that this can be a time period in which students' motivation declines significantly and thus, motivational problem can become more central during this time. Students' school achievement, in turn, also may be affected by their decreased motivation. Taking these issues into consideration, to explore middle students' motivation profile and the subsequent learning outcomes in physical education may contribute to our understanding of the extent to which middle school students respond to a social environment defined by a social constructivist curriculum with respect to their needs, motivation, and learning. Results from this study may provide insightful information for

future curriculum development to encourage student cognitive knowledge and skill learning and increase student learning in middle school physical education.

Definitions of Key Concepts

Amotivation is neither intrinsically nor extrinsically motivated and it occurs when individuals do not value the activity, do not anticipate the subsequent outcomes of the expected behaviors, or feel incompetent (& Deci, 2000a).

External regulation is the most basic form of regulation that an individual adopts in order to satisfy an external demand or reward contingency (Ryan & Deci, 2000b).

Extrinsic motivation refers to the drive of an activity in order to attain the expected outcomes (Ryan & Deci, 2000a).

Identified regulation is a more self-determined form of extrinsic motivation that external regulation has been accepted as personally important (Ryan & Deci, 2000b).

Integrated regulation is the most self-determined form of extrinsic motivation that “identified regulations have evaluated and brought into congruence with one’s other values and needs” (Ryan & Deci, 2000b, p73).

Internalization refers to the process through which individuals integrate the values, beliefs, or attitudes of the social environment and progressively transform them into personal values, goals, or regulations (Deci & Ryan, 1985; Ryan & Deci, 2000a).

Intrinsic motivation is defined as the drive to engage in an activity for the activity’s inherent interest or enjoyment rather than for outcomes external to the activity (Ryan & Deci, 2000b).

Introjected regulation is an internally controlling regulation in which an individual complies with the desired behavior not because they want to but because they feel they have to (Deci & Ryan, 1985).

Learning in physical education is defined as a relatively permanent behavioral change resulting from experience of physical movement associated with cognitive understanding of the movement (Rink, 2001).

Motivation is the process that energizes behavior and gives the behavior direction (Deci & Ryan, 1985).

Needs refers to innate psychological nutrients that are essential for ongoing psychological growth, integrity, and well-being (Deci & Ryan, 2000b).

Need for autonomy is the basic need to experience oneself as the origin of one's behavior (Deci & Ryan, 1985).

Need for competence is the basic need to experience satisfaction in one's ability and effectiveness in one's ongoing activities (Deci & Ryan, 1985).

Need for relatedness is the basic need to experience connectedness to others and the sense of belongingness both with one's community and with other individuals (Ryan & Deci, 2000a).

Self-regulation is "the energization and guidance of behavior on the basis of integrated awareness, informed by basic needs" (Ryan & Deci, 2000c, p. 47).

APPENDIX B

EXTENDED REVIEW OF LITERATURE

Optimal learning occurs when students' needs for knowledge acquisition, motivation, and other desired outcomes of education are satisfied (Alexander, 2005).

Possessing optimal motivation to learn is one of the most critical and important necessities for learners. Researchers have developed a number of theoretical models in the past 30 years in an attempt to better understand and explain motivated learning behavior and process (see Sansone & Harackiewicz, 2000; Wigfield & Eccles, 2002).

In this chapter, first, I will begin with an overview of conceptions of learning and learning in physical education. Second, I will discuss and critique selected contemporary motivation constructs that are widely studied and applied in education, physical education, physical activity, and sport settings. These constructs include, namely, goal theory, expectancy beliefs and task value theory, and interest-based motivation theory. Third, I will discuss and critique the self-determination theory on which this study is based and its relevance for motivating physical education students to learn knowledge and skills needed for life-long healthful living. Fourth, I will discuss curricular ramifications of the self-determination/regulation theory, especially in the context of physical education.

Conceptions of Learning and Motivation: An Overview

Learning

Learning is one of the most important topics in education and is also an extremely difficult concept to define (Hergenhahn & Olson, 2005). Historically, the conceptualization of learning has evolved from a behaviorist perspective to a cognitive perspective. Originally derived from British empiricist notions of knowledge acquisition

(Reynolds, Sinatra, & Jetton, 1996), behaviorists conceptualize learning as a process of behavioral conditioning and re-conditioning (Alexander, 2005). The cognitive perspective, on the other hand, primarily postulates that learning involves more than mere conditioning and re-conditioning behavior and is an active rather than a passive process. In the following sections, the definitions of learning will be discussed by comparing the two perspectives.

Behaviorism. In Pavlov's classical conditioning theory (Windholz, 1992), a stimulus (e.g., food) that will cause a natural and automatic behavioral response (salivating) is called an unconditioned stimuli (US). When a stimulus that is not related to the behavioral response (conditioned stimulus - CS) is repeatedly used immediately after the US, the CS alone then can cause the organism to demonstrate the same behavioral response. The behavioral response from CS alone is considered a conditioned or learned response.

Skinnerian operant conditioning holds that varied reinforcing stimulus (e.g., food) immediately following the CS will increase the strength of an expected behavior (Reynolds et al., 1996). In addition, when reinforcement is made contingent on the expected behavior repeatedly, the behavior will be acquired; thus learning occurs (Hergenhahn & Olson, 2005). The stimuli-response-reinforcement framework implies that learning is manifested in behavioral change (Skinner, 1957) and can be studied by directly observing the learner's behavioral change.

As a modern behaviorist, however, Kimble (1961) believed that learning should be perceived as a process, rather than a product, such as an observable behavior. He argued that behavioral changes result from learning, and learning as a process cannot be

studied directly. Therefore, learning is defined “as a relatively permanent change in behavioral potentiality that occurs as a result of reinforced practice” (Kimble, 1961, p. 6). Hergenhahn and Olson (2005) further redefined the concept to take into account experiences other than those being reinforced and encompassing longer than the immediate time span: learning is “a relatively permanent change in behavior or in behavioral potentiality that results from experience and cannot be attributed to temporary body states such as those induced by illness, fatigue, or drugs.” (p. 8).

Although modern behaviorist learning theory acknowledges learning as a process involving more than reinforced behavioral experiences, the theory leaves little room for explaining the function of the mind (Reynolds et al., 1996) and is unable to explain the role and function of active thinking and reasoning (Alexander, 2005). To clarify the concept, psychologists started to look for other approaches to explaining the nature of learning during the 1950s~1960s (Shuell, 1986) and have generated a few viable theories including the information-processing theory and constructivism.

Cognitivism. The information-processing theory explains learning using an analogous model of computer algorithms characterized by a process of continuous self-modification (Siegler, 1998). The self-modification framework includes three cognitive memory structures: sensory, working, and long-term. Information is processed through the structures via continuous encoding and decoding. The coding process is automated and coded information is stored in sensory, working, and long-term memories as needed. When a piece of information reaches and is stored in long-term memory, it becomes acquired knowledge. Siegler (1998) stated that it is the automated processing that

provides the basis for learning. An individual's ability to encode and decode either limits or enhances the effects of information processing, and subsequently learning.

Despite its initial popularity, the information-processing theory has been challenged by many psychologists and educational researchers. Alexander (2005) summarized the criticisms that the theory only addresses learning information pulled from and fully formed in the external environment, assuming that learning occurs merely as receiving, resulting from human reaction to the external information. Thus, the theory overlooks human being's ability to actively construct knowledge. In addition, the linear and uni-directional framework (sensory to long-term memories) can be problematic in that little consideration is given to individual learner's prior or background knowledge.

To address the weaknesses, psychologists and educational theorists put their research emphasis on studying learning as a dynamic individual-environment interactive process. Their effort has led to the theories of constructivism. These theories share a fundamental assumption that knowledge is not simply acquired passively but is constructed actively by individuals or groups. In other words, the constructivist learning theories provide alternative frameworks that reiterate a belief: knowledge and knowing cannot exist without human construction (Alexander, 2005).

Among several schools of constructivism, social constructivism has received most attention lately in educational research. Social constructivism claims that "learning is a necessary and universal aspect of the process of developing culturally organized, specifically human psychological function" (Vygotsky, 1978, p. 90). In other words, learning occurs when the learner internalizes the social experience of interacting with others. Vygotsky's concept of "Zone of Proximal Development (ZPD)" emphasized the

role that knowledgeable and/or experienced others play in the learning process and the importance of social-interaction between the knowledgeable person and the novice. Learning, from this perspective, is a process of psychological function resulting from the individual-social interaction in a given social environment (Vygotsky, 1978).

Although cognitive learning theorists attempted to investigate and define learning from different approaches, they share a common notion that learning is an active process. Social constructivism scholars postulate that learning is a constructive process that resides within the interaction between the learner and the social environment. Learning can be inferred in terms of change in behavior, but change in behavior may not be resulted from learning. Optimal learning occurs when the learner becomes actively engaged in the cognitive process and uses prior knowledge in the process of social interaction with knowledgeable others.

Learning in physical education

Physical education is a unique discipline in education in that it is concerned with development in the psychomotor domain as well as in the cognitive and affective domains (Rink, 2003). Physical education has its own formal body of knowledge with content themes centered on physical movements. Metheny (1971) indicated that the learning process in physical education, under the influence of behaviorism, was identified as “something that was done to a child’s body to make it stop wriggling and squirming” (p. 14).

Even though the concept of learning in physical education includes that learners actively do many tasks and learn by doing them and recognizes that the social interaction play an important role in learning, Metheny (1971) argued that leaning can only occur in

physical education when students find the movement activities or experiences meaningful in their own right. Learning in physical education, thus, is also conceived by some philosophers and curricular specialist to be meaning-centered. Although this meaning-centered learning perspective has never been in dominance in mainstream physical education, the idea that teachers and physical educators need to help students seek personal meaningfulness during their learning process has been broadly accepted (e.g., Jewett & Mullan, 1977; Jewett, Bain, & Ennis, 1995).

The understanding of learning in physical education shares strong resemblance to the theoretical development in educational psychology. Based on the information-processing learning theory, Marteniuk (1976) postulates that motor programs (i.e., memories of movement) are developed in a system of proper hierarchical and sequential progressions. When a motor skill is practiced, a sequential progressive program is coded into the hierarchical memory system for recall at a later time. To this extent, learning has taken place. Thus, learning in physical education cannot happen without learners' cognitive processing motor information. Guided by this approach, most motor skills are better learned in well-sequenced and programmed pieces. It is not expected that physical education students learn a complicated motor skill as a whole.

Schmidt and Wrisberg (2000) used a three-stage framework to elaborate motor skill learning. Rather than breaking motor skill into several parts, they proposed that motor skill learning includes a verbal-cognitive stage, a motor stage, and a autonomous stage. In the verbal-cognitive stage, learners think about what strategies they need to use. During the motor stage, learners think about how to refine the skill and identify movement patterns and effective actions. In the autonomous stage, learners' thinking

focuses on the perfection of performance and the satisfaction of affective needs associated with the performance.

Because learning in the physical domain involves autonomous performance at a high level often, Lambert (2003) argued that simplistic and isolated skills cannot be considered as learning outcome in physical education. More specifically, she warned that, except for closed skills, skills performed in a rote manner without its complex context is relatively meaningless to the individual. In addition, Lambert insisted that true learning in physical education can only occur when the confluence of knowledge, skill, and practices in applied settings has been reached.

From the social constructivist perspective, Ennis (2003) proposed a value-context model to describe relevant factors in the educational environment “directly affecting what, how, and how much students learn in physical education” (p.114). In this model, as seen Figure 2.1, student learning is in the center and directly influenced by the curriculum planning and teaching process. The inner circle is the school context which includes curriculum plan, teacher practice, and student responses. This circle emphasizes the process of curriculum decision-making and how the curriculum facilitate student learning in a particular school and class environment. The second circle is concerning the influence of values and beliefs that are held by students, families, teachers, peer groups, and administrators. These values and beliefs are considered to influence student learning directly. The outer circle of the model is the global and pervasive context influences, defined by the climate of expectations and performance within the physical education setting. All circles present in the model indicate critical components necessary for student learning in physical education.

Figure 2.1 The Value-Context Model (Ennis, 2003, p. 115).

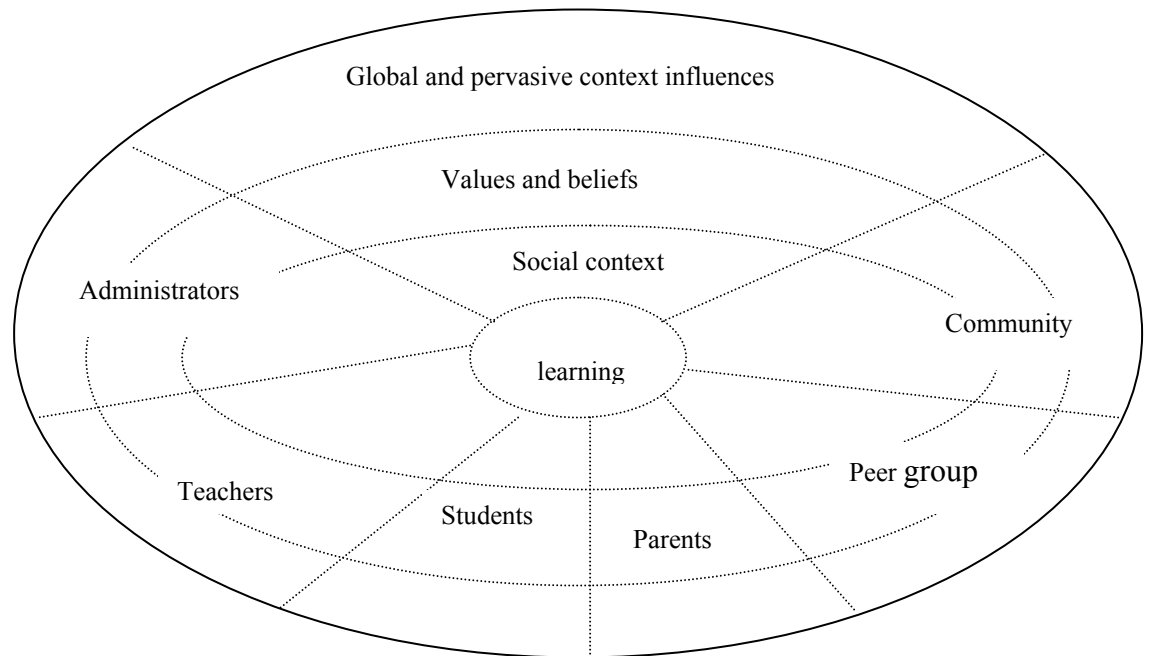

In summary, theories of learning in physical education also have gone through a transition from behaviorism to cognitivism. Although the view of learning in physical education is centered on motor movement, researchers agree that psychomotor learning is inseparable from the cognitive process (Jewett et al., 1995). In general, learning in physical education is defined as a relatively permanent behavioral change resulting from experience of physical movement associated with cognitive understanding of that movement (Rink, 2001).

Motivation

The term of *motivation* is derived from the Latin verb *movere* (Pintrich, 2003). Motivation is something that gets human beings doing the activity and helps them get the

tasks done (Pintrich & Schunk, 1996). With respect to the process whereby motivation occurs, there have been two different perspectives historically: behaviorism and constructivism. Behavioral theorists view motivation as a change in the frequency of occurrence of a behavior or response (Pintrich & Schunk, 1996). From a behavioristic view point, motivation is nothing more than a high possibility of an expected behavior whereas individuals' feelings and thoughts are not considered. Cognitive theories, on the other hand, view motivation as an internal process including beliefs, values, affects, attributions, goals, perceptions of competence, and social comparison (Pintrich & Schunk, 1996). From the cognitive standpoint, Pintrich and Schunk (1996) defined motivation as "the process whereby goal-directed activity is instigated and sustained" (p. 4). They explained that because motivation is a process and therefore motivation cannot be observed directly. Behaviors, such as choice of tasks, persistence, effort, verbalization, and achievement can be used to infer motivation.

In education, student learning behaviors are characterized by their choice of learning tasks, persistence in practice, the vigor in carrying out assignments, and demonstration of achievement (Wigfield & Eccles, 2002). From the cognitive perspective, research on motivation in education in general supports the notion that these characteristics are based on students' achievement goal orientations (Nicholls, 1984), beliefs of success and conception of task values (Eccles et al., 1983), interest in the content (Renninger et al., 1992), and determination of behaviors (Deci & Ryan, 1985). In the past two decades, motivation theories that have evolved from these constructs or motivators have been heavily studied in education and physical education. In the following sections, I will review and critique these theories as background information. I

will give an in-depth discussion of the self-determination theory that I believe is particularly important and applicable to K-12 student learning of knowledge and skills needed for active and healthful living.

Select Contemporary Motivation Constructs

Goal Theory

According to Urdan (1997), the contemporary conception of achievement goals took form around 1980. There have been two main research areas on student motivation in terms of goal constructs and their motivation function on student learning (Pintrich, 2003). One area focuses on goal content and the multiple goals that students can pursue in school setting. Another area focuses on the nature of achievement goals or goal orientation including both personal goal (the goal that student pursues) and the goal structure (the goal that student perceives). It is within these two paradigms that researchers have conducted numerous studies.

Achievement Goal Approach

Goal orientation. Achievement goals are basically concerned with the purpose of achievement behavior (Ames, 1992). Ames (1992) defines achievement goals as integrated patterns that include beliefs, affect, and attribution. The integrated patterns determine intentions of individual behavior. In general, the achievement goals can be represented by individuals' different ways of approaching, participating, and reacting to achievement related activities.

In addition to the general conception, the achievement goals have been postulated in specific ways. Nicholls (1984) proposed a dual-goal structure of task/mastery - and ego/performance-involved goals. The task/mastery goal orients students toward learning

and understanding, developing skills, and focusing on self-improvement using self-referenced standards of success. The ego/performance goal, in contrast, orients students toward demonstrating ability, striving for recognition of high ability, and focusing on comparative standards of success relative to peers' performance. A vast body of research evidence indicates a strong relationship between the mastery goal and positive cognitive, motivational, affect, and behavioral outcomes and a relationship between the performance goal and maladaptive outcomes (Ames, 1992; Dweck & Leggett, 1988).

Recently, research on achievement goals has moved beyond the dual-goal construct toward an understanding of multiple goals. Elliot (1999) proposed that within each of the mastery and performance goals, students take either an approaching or avoiding strategy to define and choose personally meaningful goals. For example, the performance-approach goal orients students toward defining achievement in reference to peers and demonstrating high ability. Conversely, the performance-avoidance goal leads students to avoid demonstrating low ability or appearing stupid or dumb. The approach-avoidance distinction may also apply to the mastery goal (Elliot, 1997; Pintrich, 2000). For example, students with the mastery-avoidance goal may attempt to avoid misunderstanding or demonstrating inability to master the material (Pintrich, 2003).

The motivation function of the multiple goal construct is complex. Pintrich (2003) suggested that it is important to consider the interactions among multiple goals and how the different types of mastery and performance goals may interact to produce different outcomes. One interesting finding (Elliot & Church, 1997) is that the combination of a high performance-approach goal and a low mastery goal was associated with the highest grades, whereas the combination of a low performance-approach goal and a high mastery

goal was associated with highest levels of intrinsic motivation. Based on these results, they suggested that the simultaneous adoption of mastery and performance-approach goals may result in an optimal self-regulatory profile of student motivation. However, Midgley and colleagues (Midgley, Kaplan, & Middleton, 2001) argued that such a suggestion and the interaction of multiple goals that Elliot and Church (1997) reported seem to contradict each other because a high/high combination may not be the most optimal pattern for either motivational or academic outcome. Midgley et al. (2001) explained that the mastery goal might undermine possible positive effects of the performance-approaches goal on performance while the performance-approach goal might undermine the positive effects of the mastery goal on intrinsic motivation.

Research on motivation function of the multiple goal construct (e.g., Elliot & Church, 1997; Pintrich, 2003) suggests that performance goals may not be as maladaptive as asserted in the dual-goal theory (Pintrich, 2003). These goals may result in an increase in actual achievement and performance, such as positive self-concept, affect, attitudes, course grades, test scores, and the valuing of academic work (Harackiewicz, Barron, Pintrich, Elliot, & Thrash, 2002; Midgley et al., 2001). On the other hand, the extent to which the performance-approach goals may lead to adaptive outcomes is not universally supported in research findings. Midgley and colleagues (Midgley et al., 2001) summarized that many studies that have found a positive performance-approach have either no relation or a negative relation with adaptive behaviors. For example, Elliot and McGregor (1999) examined performance-approach goal, mastery goal and grades in both short-term and long-term learning in an introductory psychology course. They found that performance-approach goals were positively related to grades on an expected exam

during the course, while mastery goal was unrelated to grade. However, when students' goal orientations and their grades on an unexpected pop quiz given near the end of a course were examined, performance-approach goal was found to be unrelated to the grade, whereas the mastery goal was positively related to the grade. Therefore, Elliot and McGregor (1999) concluded that it is the mastery goal rather than the performance-approach goal functions as a facilitator of long-term, deep learning.

Goal structure. In addition to students' personal goals, the achievement goal orientation approach also attempts to explore the characteristics of learning environment that may influence students' goal orientation. Specifically, researchers in this field have made an effort to address the issues, such as what kind of structures of the classroom or other learning environments may lead to different achievement goal orientations and what characteristics of these structures affect students' engagement in learning (Ames, 1992). Ames (1992) suggested that several salient structures within the learning environment, especially the classroom environment, need to be taken into consideration. These structures include the design of learning tasks, use of rewards and the way of evaluation or recognition, and distribution of authority or responsibility. Ames argued that tasks with characteristics of variety, diversity and challenge are more likely to encourage an interest in learning and a mastery goal orientation. Teachers' choice of evaluation methods is one of the most salient structures that can affect students' motivation. Ames & Ames (1984) indicated that the way that assessments are structured may orient students toward different achievement goals and different patterns of motivation. Specifically, the distribution of authority or responsibility concerns whether teachers support student autonomy or attempt to control the process of learning. In other

words, it concerns whether teachers give students options or offer choice or involve students in decision making process. Ames (1992) suggested that teachers can make a learning-conducive mastery goal environment by placing high value on the learning process through designing meaningful learning tasks for mastery not competition, emphasizing self-reference standards in evaluation, and offering students opportunities for self-directing learning.

Similarly, Epstein (1988) also argued that various structural features of a learning environment can influence students' motivational process. She proposed the concept of "TARGET" to represent the structures of Task, Authority, Recognition, Grouping, Evaluation, and Timing. Different from Ames (1992), this approach separates recognition from evaluation. To illustrate, recognition in this approach refers to the use of rewards and incentives. In addition, this approach considers grouping and timing as critical structures of the learning environment. Grouping structure concerns the way teachers bring students together or keep them apart. Treasure (2001) stated that placing students in homogeneous ability groups are more likely to create a social comparison learning context. Instead, heterogeneous and varied group arrangements are more likely to facilitate a mastery-oriented environment. Time designated for instruction and the time allotted for students to complete tasks have been considered as significant factors that influence students' motivation (Epstein, 1988). Treasure (2001) indicated that some students may need more time than the actual instructional time to develop skills necessary to be competent to participate in the activities. Furthermore, Ames (1992a) indicated that the timing dimension is related to other structures. For example, with

respect to task design, it is important for teachers to consider how much time they will give students to accomplish a certain learning task.

The structures described above define the motivational climate of a learning context when they are taken together (Treasure, 2001). Research has been shown that a mastery-oriented learning environment is related to adaptive or positive cognition, motivation, and affect pattern. For example, Ames and Archer (1988) examined the relations between students' perception of mastery and performance goals and their learning strategies and motivational patterns with 176 academically advanced students in grades 8-11. They found that the students who perceived their classes as emphasizing a mastery goal were more likely to use effective learning strategies, preferred challenging learning tasks, had more positive attitude towards their class, and believed effort lead to success.

Content Goal Approach

Content goal approaches (e.g., Ford, 1992; Wentzel, 2000) define and delimit student goals in relation to those in the content that students are expected to pursue and achieve in schooling. From this perspective, a goal is defined as “a cognitive representation of what it is that an individual is trying to achieve in a given situation” (Wentzel, 2000, p. 106). Wentzel (2000) argued that it is essential to adapting the content goal perspective to motivation to allow a holistic goal approach to achievement.

Basically, content goals are categorized as social goals and academic goals (Wentzel, 1996). Social goals reflect students' purpose to work with classmates, to please or receive approval from others, to establish relationships or friendships with teachers or peers. In the domain of social goals, pro-social goals (goals of helping or cooperating

with teachers or peers) and social responsibility goals (goals of following rules or keeping commitments) are of particular interests in research (Wentzel, 2002). Academic goals are task-related goals such as to master disciplinary knowledge or skills, to achieve a self-referenced or criterion-based standard, to satisfy intellectual challenge, or to engage in critical or creative thinking. The academic goal in the content goal approach is the counterpart construct of achievement goal in the achievement goal approach.

To examine these goals and their relations to academic performance, Wentzel (1993) conducted a study with 423 sixth- and seventh-grade students to assess their mastery, evaluation, and social responsibility goals. Among these goals, mastery and evaluation goals represent academic goals and social responsibility goals are deemed the social goal. The mastery goals were operationally defined as “attempts to achieve mastery and to learn new things simply for the sake of doing so,” the evaluation goals were defined as “attempts to receive positive evaluations of the self or of academic work” (Wentzel, 1993, p.10). The social responsibility goals were operationalized as attempts to “be both prosocial and compliant at school” (p. 9). Students’ academic achievement was assessed by their GPA and standardized test scores.

Results indicated that pursuit of these goals simultaneously is positively related to students’ academic achievement. The students who frequently pursued the multiple content goals earned higher grades than did the students who did not. Interestingly, the evaluation goals (conceptualized equivalent to ego/performance goals in the study) are stronger predictors of student grades than mastery goals. On the other hand, students who had mastery-oriented goals displayed better academic achievement than did students who had evaluation or responsibility goals. Responsibility-goal oriented students earned the

lowest grades. The findings appeared to support the notion that the evaluation goals may have a positive relationship with adaptive outcomes.

Although the findings of this study supported the argument that content goals link students' goals and academic achievement (Wentzel, 1993), it is not clear whether and how the content goals are related to students' beliefs about effort, attribution for achievement, and affective responses to learning (Aims, 1992). The findings seem to imply that motivation and success in a school-based achievement setting may require consistency between the disposition goals and academic content. Social goals alone help little in achieving academically.

Expectancy-value Theory

Expectancy-value theory states that children's competence-expectancy beliefs and perceived task values in the content are important determinants for their motivation to perform in achievement settings (Wigfield & Eccles, 2002). Wigfield, Eccles, and colleagues proposed an expectancy-value model (Eccles et al., 1983; Wigfield & Eccles, 2000) and proposed that student expectancy beliefs and perceived values are assumed to directly influence achievement choices, performance, effort, and persistence. Based on their own research (e.g., Eccles et al., 1983) and others' work (Atkinson, 1966, cited in Wigfield & Eccles, 1992), Wigfield and Eccles (2000) tested and articulated the expectancy-value model of students' academic achievement motivation. This model consists of two integral parts: expectancy beliefs and task values

Expectancy beliefs. Expectancy beliefs for success are defined as children's beliefs about how well they will do on an upcoming task that may happen either in the immediate or longer term future (Eccles et al., 1983). Wigfield and Eccles (2000)

articulated that these expectancies beliefs are individuals' expectations for success rather than their outcome expectations. Outcome expectations, according to Bandura (1997), refer to individuals' beliefs that a given behavior will lead to a given outcome. In addition, Wigfield and Eccles (2000) explained that the expectancy construct in their model is similar to Bandura's (1997) efficacy expectation that refers to individuals' beliefs about their ability to successfully accomplish a task (Bandura, 1997).

Expectancy beliefs for success are different from perception of competence (Eccles & Wigfield, 2002). Perception of competence is a belief about ability defined as the individual's perceptions of his or her current competence for a given activity. The conceptual difference between expectancy beliefs for success and perception of competency is that perception of competence focuses on the current ability level and expectancy beliefs focus on their future success (Wigfield & Eccles, 2000). Although these two constructs can be theoretically distinguished from each other, empirically they are highly related and indistinguishable especially among school-age children.

Task values. Perceived *task values* represent students' perceptions of attractiveness of a particular task or content (Eccles et al., 1983). Eccles and her colleagues (1983) assumed that task value is determined by the nature of interaction between the task and the individual's goals, values, needs, and motivational orientations, and affection associated with similar tasks in the past. The task value construct consists of four distinct components often identified by the learner in learning tasks: attainment value or importance, intrinsic value or interest, utility value, and cost (Eccles et al. 1983).

Attainment value refers to the personal importance of doing well on a task as well as how central the task is perceived to be to the learner's personal identity. According to

Wigfield and Eccles (1992), tasks provide opportunities for the learner to demonstrate competence in different domains. Thus a task will have higher attainment value if it allows the learner to confirm salient aspects of their competence. *Intrinsic value* refers to the inherent enjoyment or pleasure the learner perceives receiving from engaging in the task. Eccles et al. (1983) also defined it as interest the learner perceives in the task. A learner is likely to become intrinsically motivated to engage in the task if it has high intrinsic value that provides positive psychological consequences. *Utility value* is defined as the learner's perception of usefulness of the task. It is determined by how well a task relates to current and future goals. A task can have utility value when it facilitates important future goals of the learner, even if it is not interesting or enjoyable (Wigfield & Eccles, 2002). *Cost*, the last component, is conceptualized as a negative aspect in the expectancy-value model. Cost refers to the negative aspects of engaging in a specific task. These aspects include how engaging in one task limits access and opportunity to others, emotional and physical expense the task will take, such as performance anxiety, fear of failure, and, sometimes, fear of success.

Research on the expectancy-value model. Eccles and Wigfield and their colleagues conducted series longitudinal studies primary with k-12 learners (e.g., Eccles & Wigfield, 1995; Eccles et al., 1989; Wigfield et al., 1991; Wigfield et al., 1997) intended to answer two broad research questions: (1) how learner expectancy belief for success and domain specific task values change across the school years; and (2) how the beliefs and task values influence their activity choice and performance in achievement settings (Wigfield & Eccles, 2000). In their research, the researchers primarily used survey methodology to clarify the constructs in the model, examine the role of each

construct in different knowledge domains (including sport), and monitor the changes of expectancy belief and task values as children grow.

Findings of these longitudinal studies (e.g., Eccles et al., 1998; Wigfield & Eccles, 2002) revealed that task values are predictive of choice decisions and future engagement whereas expectancy beliefs predict the achievement after individuals actually engage in a given activity. In mathematics, for example, Meece, Wigfield and Eccles (1990) found that students' expectancies for success and beliefs about their ability are stronger predictors of their performance than their perceived task values of math,

Expectancy beliefs and task values decline over time. Wigfield et al. (1997) followed groups of children ($n=615$) from grade 1, 2, and 4 for three years and measured their expectancy beliefs in terms of how good they were at each activity, how good they were relative to the other things they were studying, how good they were relative to other children, how well they expected to do in the future at each activity, and how good they thought they would be at learning something new in each domain. Wigfield et al. (1997) found that children's expectancy beliefs for math, reading, instrumental music, and sports declined across the elementary school years. Perceived task values (except cost) declined as well. Cost, although considered an important component in the model, has rarely been measured in most studies. It is not clear why this aspect has not been examined.

More recently, after an analysis of a decade-long longitudinal data set, Jacobs, Lanza, Osgood, Eccles, and Wigfield, (2002) concluded that children are able to develop a self concept system with many beliefs about self and the activities in which they participate. This system leads to changes of expectancy beliefs and task values over time and, in turn, the changes of expectancy beliefs and perceived values in content domains

result in changes of motivation in learning the content. With physiological and psychological development, children are able to stabilize the self-concept system to inform an activity-specific expectancy for success and determine specific task values in a specific task or a content domain (e.g., English, mathematics, sport, physical education). During development, the expectancy beliefs and perceived task values in any given content domain are developed simultaneously. Learners are constantly assessing their competence, possibility of succeeding in learning, and the value of the content to their lives. By attaching or detaching the values (i.e., attainment, intrinsic, utility, and cost), the learner is able to determine for him/herself the meaning of the content, and to make his/her choice decisions on whether and/or to what extent he/she should put forth effort. In other words, the expectancy - task value based self concept system eventually forms a foundation for motivation that a learner relies on to motivate (or demotivate) him/herself in learning and determine the level of effort of engagement.

Interest

Dewey has been recognized as one of the earliest and most influential people to emphasize the important role of interest in learning in the United States (Schraw, Flowerday, & Lehman, 2001; Schraw & Lehman, 2001). After Dewey, attention to students' interest was ignored for almost 50 years largely because of the prevalence of American behaviorism (Schraw et al., 2001; Schraw & Lehman, 2001). Even though concepts of interest have been revived by researchers (e.g., Hidi, 1990; Krapp, Hidi, & Renninger, 1992), current theoretical and empirical work on the construct of interest is still rather young in comparison with the traditions of the expectancy-value theory and the goal theories (Pintrich & Schunk, 1996).

Contemporary interest theorists have expanded Dewey's work on interest into a more complex framework. Interest has been conceptualized as individual/personal and situational (Krapp et al., 1992). *Individual interest* refers to a person's psychological disposition in preference of an activity or an action. Individual interest is a relatively stable and enduring disposition (Krapp et al., 1992). *Situational interest*, on the other hand, is defined as a psychological state that is elicited by certain aspects of the immediate environment, such as the ways in which learning tasks are organized and presented (Krapp et al., 1992). In addition, Ainley, Hidi, and Berndorff (2002) proposed to reinforce the concept of topic interest. It is assumed to be a type of individual interest only manifest when a specific topic (situational interest) is presented.

Individual interest. Individual interest is specific to each individual, or is individually varying. Renninger (2000) asserted that individual interest derives from stored knowledge and value. Knowledge, according to Renninger (2000), refers to an individual's developed understanding about an object or activity. For individual interest to emerge, sufficient knowledge about the object is a necessary and sufficient condition. The value component centers on an individual's appreciation for an object or activity that is based on either positive emotions derived from the person-activity interaction or the recognition of the importance of the engagement.

It is commonly believed that students will be highly motivated and engaged in a learning task if they have high individual interest in it. Individual interest also enables students to persist even if they are facing failure and feeling frustration (Renninger, 2000; Renninger & Leckrone, 1991). However, from a practical perspective of education, Hidi and Anderson (1992) postulated that using students' individual interests as a primary

motivational tool in education can be difficult because of the diverse nature of individual interests among learners. In addition, individual interest is strongly associated with existing knowledge, value, and positive emotion about the object or activity (Krapp et al., 1992). It is unrealistic to expect students to have sufficient knowledge and values about the content they are beginning to learn in schools. These two factors, unfortunately, make it extremely difficult for teachers to utilize students' individual interests in learning what they might not be interested in in the first place.

Situational interest. Situational interest, on the other hand, is characterized by spontaneity. A situationally interesting activity can immediately attract learners' attention, involve them in the process, and provide instant, positive feelings about the activity (Hidi, & Harackiewicz, 2000). Given this unique characteristic of spontaneity, situational interest is considered to be a motivator that the teacher *can* control to a certain extent (Schraw et al., 2001).

Schraw and Lehman (2001) categorized situational interest into three groups: text-based, task-based, and knowledge-based. Specifically, text-based situational interest refers to the interest that generates from the properties or aspects of the oncoming learning information, typically a text. Schraw and Lehman (2001) further elaborated that there are three subcategories included in text-based situational interest. These three subcategories are seductiveness, vividness, and coherence. Seductiveness describes the text segments that are highly interesting but not important. Its effect on student learning is still under debate. In other words, it remains unclear that the seductive details are beneficial or detrimental to student learning (e.g., Harp & Mayer, 1998; Schraw, 1998). Vividness refers to the text segments that stand out in that they create suspense, surprise,

or are uniquely engaging (Schraw & Lehman, 2001). Research has found that vividness seems to enhance students' perceived situational interest and performance on recall test (e.g., Schraw, 1997; Wade, Buxton, & Kelly, 1999). In addition, research has also indicated that vividness appears to have multiple dimensions including unexpectedness (Hidi, 1990), suspense (Schraw, 1997), and imagery (Goetz & Sadoski, 1995). Coherence refers to factors that affect learners' ability to organize the main ideas in a text (Schraw & Lehman, 2001). Similar to vividness, coherence of the text has been found to have positive influence on situational interest and student learning (e.g., Wade et al, 1999; Schraw, Bruning, & Svoboda, 1995).

Task-based situational interest refers to the interest triggered by changing the task itself or by changing the way learners approach the task. Most of the research on task-based situational interest has been conducted in reading. For example, Schraw and Dennison (1994) assigned different perspectives of a text passage to college students. They found that such encoding-task manipulations had an important impact on students' perceived interestingness of the passage. The utility of changing a task, a text in particular, to enhance students' situational interest is still under debate. Specifically, a group of studies in reading has indicated that different versions of the same text can have different impact on learners' perceived situational interest and recall scores (e.g., Graves, Slater, Roen, Redd-Boyd, Duin, Furniss, & Hazeltine, 1988). Meanwhile, another group of studies (e.g., Wade, Buxton, & Kelly, 1999) has found that the situational interest and recall patterns are almost identical for the different versions of the same text.

Research on both individual and situational interest has shown that students with a high level of either type of interest can demonstrate a high level of cognitive engagement,

increased motivation to learn, and enhanced achievement (Pintrich, 2003). In addition, Ainley et al. (2002) revealed that both individual interest and situational interest can result in increased topic interest, which, the researchers suggested, influences students' positive affective responses and, subsequently, leads to increased persistence in learning and increased achievement.

The relationship of interest and knowledge. Much of the research on interest has been focused on how interest and knowledge interact. The research has helped educators understand the dynamic relationship between motivational and cognitive constructs. For example, to explore the interrelationship of knowledge and interest, Alexander (1998) proposed a model of domain learning (MDL). In the MDL, development in a particular field of study is characterized by progression from an acclimated or naïve stage of learning, to a competent stage, and potentially, to a stage of proficiency or expertise. Acclimated learners have very little domain knowledge and topic knowledge. During this stage, the learner has little deep-seated individual interest in the domain. They often are more concerned with getting through the task than developing competency or proficiency in the domain. Thus, in this stage, interest is more transitory or short-lived. In other words, interest in this stage is more likely to be situational interest which has contextualized or situation-specific nature.

With increased exposure to a domain over time, many learners will move to a stage of competence. Although competent learners may continue to be attracted to situationally interesting aspect of a task or context, their individual interest to learn may become stronger. Therefore, in this stage, individual interest and situational interest may

interwind and students may be attracted to engage in learning tasks by both individual and situational interests.

The proficiency stage is the most advanced level of domain learning although relatively few k-12 learners reach this particular stage. MDL assumes that learners in this stage have developed a deep individual interest in the domain. Empirical studies have also supported these assumptions (Alexander, Kulikowich, & Schulze, 1994; Alexander, Jetto & Kulikowich, 1995). For example, Alexander et al (1995) conducted two experiments to explore the relationships among learners' knowledge bases, interests, and retention with groups of premedical students, graduates, and regular undergraduate students in the domains of human immunology and physics. The researchers found that the students with high domain knowledge were likely to demonstrate higher individual interest in the domain and perform better in free-recall knowledge tests than those with low knowledge. Alexander et al (1995) argued that the finding indicated a knowledge-interest covariation relationship through the domain learning stages. The findings further reiterate the dynamic and complex nature of the relationships among knowledge, individual interest, situational interest, and learning.

Summary

Contemporary research in achievement motivation has been focused on a few powerful constructs including achievement goal orientation/climate, expectancy beliefs and perceived task values, and individual and situational interests. These constructs have been examined in relation to student learning behaviors and achievement. It is clear that students are able to adopt different types of goals and adapt to the classroom climates or structures that the teacher creates. Students' expectancy beliefs can predict their

achievement whereas the task values may determine their motivation to learn the content in a specific knowledge domain. Both expectancy beliefs and perceived task values tend to decline over school years, especially in the transition from elementary to middle school. Recent research on interest has revealed that both individual and situational interests are related to students' learning and are assumed to interact with students' knowledge in a specific domain. Because of the diverse nature of student individual interest, it is very difficult for teachers to use it as a primary motivator in the classroom. It is recommended that situational interest be considered as a motivation source that teachers should control and use to enhance student learning.

Although there are unanswered questions about these motivation constructs, research findings from the past few decades suggest a positive outlook about them. Their motivation functions are apparent and have advanced our knowledge about the way learning should be defined. The research findings also have formed a basis on which children and adolescent motivation in many aspects of their schooling and lives can be studied and understood, including motivation in learning in physical education and motivation to develop an active and healthful lifestyle.

Motivation in Physical Education

Research on learner motivation in physical education has developed parallel with the research development in education. Although physical education focuses on learning a variety of in movement forms, the learning shares commonalities observed in classrooms' learning, which requires high motivation, high cognitive engagement, as well as physical movement. Motivation research in physical education, thus shares tremendous common ground as that in general education. Recent studies have adopted and used

similar theoretical frameworks/constructs I discussed above. Below I will focus on specific research findings within each theoretical framework.

Goal Theory

Goal theory has been examined most frequently in motivation research in physical education. Similar to classroom research, it is assumed that children's motivation to learn movement knowledge and skill and fitness knowledge and activities is determined by their self-perceptions of ability, their goal orientations, and the match of goal orientations with instructional motivation climate (Duda, 2001).

Achievement goal orientations. Most of the studies have suggested that students' goal orientations are predictive of student motivation in physical education (Chen & Ennis, 2004). Mastery/task goal orientation is found to predict positive motivational or behavioral outcomes. For instance, Dempsey and colleagues (Dempsey, Kimiecik, & Horn, 1993) indicated that mastery/task goal orientation strongly predicted students' participation in moderate to vigorous physical activity. Theodosiou and Papaioannou (2006) reported that students with high task goal orientation are intrinsically motivated, value the process of learning, and are likely to adopt self-regulatory cognitions and behaviors in physical education. On the other hand, in a sample of 824 secondary school students, Wang, Chatzisarantis, Spray, Biddle (2002) found that similar to the high task/mastery goal orientation, the high performance/ego goal orientation could predicted high motivation toward physical activity participation when it was associated with high perceived competence.

The research, however, has not provided conclusive evidence on the relationship between the goal orientations and student learning behavior and outcomes. The findings

from the few studies that actually measured students' learning behaviors and learning outcomes (e.g., Berlant & Weiss, 1997; Solmon & Boone, 1993, Chen & Shen, 2004) suggest a rather weak, though observable, association between the mastery/task goal orientation and students' adaptive learning behaviors and achievements. Chen and Shen (2004) reported that the students in their sample had stronger mastery/task than performance/ego orientation and that mastery/task orientation was related to students' in-class physical activity intensity. In addition, Sarrazin and Roberts (2002) found that mastery goal oriented students exerted more effort and performed better than did performance goal oriented students in climbing. A most recent study (Theodosiou & Papaioannou, 2006) involving 182 elementary, 365 junior high, and 235 senior high school students seems to echo the above observation. In this study, Theodosiou and Papaioannou (2006) observed moderate positive relationships of mastery/task goal orientation with metacognitive learning strategies, but found no meaningful relationships between the strategies and the performance/ego-goal orientation.

The task orientation-learning relationship, however, was not observed in other studies. For example, Solmon and Boone (1993) found that there was no difference in skill improvement between students with different goal orientations. Their findings suggested that achievement goal orientations were not predictive of skill achievement in physical education. Berlant and Weiss (1997) further confirmed that students' motor skill acquisition was not associated with students' achievement goal orientations. In addition, more recent studies indicated that students' goal orientations were not directly related to student in-class physical activity (Shen, Chen, Scrabis., & Tolley, 2003) or skill and knowledge test outcomes (Shen et al, 2003; Chen & Shen, 2004). These results indicate

that it may be premature to conclude that the mastery/task goal orientation is superior to ego goal orientation with respect to student learning in physical education.

Achievement goal climate. Research on achievement goal climate in physical education has provided much evidence that goal climate in physical education can be manipulated by teachers. Todorovich and Curtner-Smith (2003) manipulated the achievement goal climate in a study to investigate the influence of mastery and performance goal climates on goal orientations of third grade students (n=80). Students were assigned into either a task climate group, an ego climate group, or a control group. The findings indicated that students in the task-involving climate strengthened their task orientations, while students taught within an ego-involving climate strengthened their ego orientation. However, neither treatment had any impact on the alternative orientation.

Similar findings have been reported in a curriculum intervention study in which a task/mastery involving climate was created using 88 lessons and tested against a control (Digelidis, Papaioannou, Lapidis, & Christodoulidis, 2003). A group of junior high school students (n=262) was taught with the task-involving curriculum and another group (n=521) was taught the control curriculum. The students' goal orientations and perception of motivational climate were measured before and after the intervention. The results showed that students who were in the task-involving curriculum reported a stronger task-involvement climate and weaker ego-involvement climate in their classes than did those in the control curriculum. The students in the task goal orientated climate had higher post task goal orientation scores and lower post ego orientation scores..

Based on the multiple goal perspective, Carr (2006) examined the impact of the motivational climate on students' goal orientations and found that students in a

consistently high mastery/low performance climate decreased their performance-avoidance goal orientation and maintained a high level of mastery goal orientation. In contrast, students in a consistently low mastery/high performance goal climate strengthened their performance-avoidance goal orientation and weakened the mastery goal orientation. These research findings suggest that physical education teachers can actually create and control the achievement goal climates to the extent that students will be able to adapt to the respective goal orientation.

Additional evidence from these studies demonstrates a direct connection between the motivational climates and student motivated learning behavior. It appears that a mastery/task-involvement climate may lead to positive motivation and behavior in learning. For example, Solmon (1997) found that students in a mastery goal orientated environment tend to choose difficult tasks to practice and to report high intrinsic motivation. Standage et al (2003) also indicated that mastery climate could result in a high level of satisfaction in learning process. Theodosiou & Papaioannou (2006) revealed that a mastery climate is positively related to student metacognitive strategies use.

Compared with achievement goal theory, the content goal perspective, especially emphasizing social goals, has received little attention in physical education research (Guan, McBride, & Xiang, 2006). As an important goal of physical education in the United States ([NASPE], 2004), students are expected to learn “responsible personal and social behavior that respects self and others in physical activity setting and values physical activity for health, enjoyment, challenge, self-expression, and/or social interaction” (NASPE, 2004, p. 11). In addition, the pursuit of social goals, such as making friends, is related to academic outcomes including effort and achievement

(Wentzel, 1999; 2000). More studies on social goals are apparently needed in physical education to help understand students' achievement goals and social goals as well as the role of students' social goal in their school achievement (e.g., Wentzel, 1999).

Expectancy-value Theory

Research in physical education on expectancy beliefs and task values have shown distinctive presence of the expectancy beliefs and task values in students as young as elementary school (Xiang et al, 2003a). For example, Xiang and her colleagues (2003) found that 414 second and fourth grade students possessed a clearly distinguished construct structure of expectancy beliefs and task values about physical education and about the throwing task. Research findings also have revealed that expectancy beliefs predict effort and persistence (Cox & Whaley, 2004; Xiang, McBride, & Bruene, 2006) and students' performance in running tasks (Xiang, McBride, & Bruene, 2004). The task values and interest value, in particular, are strong predictors of students' intention of future participation in running activities (Xiang et al., 2004). However, the task values and their motivational functions were also found to decrease over time in physical education (Xiang, McBride, & Guan, 2004) and in sport (Jacobs et al., 2002).

The motivational functions of the expectancy beliefs and task values, however, are different in terms of outcome measures. Xiang, McBride, and Bruene (2004) examined fourth grade students' (n=119) expectancy beliefs and subjective task values in a running program designed to encourage the students to practice running to maintain health. The results showed that expectancy beliefs in current competence and future success in running tests are strong predictors of their running test scores, while the interest value of the task predict their intention to practice running in the future.

In the expectancy-value model, students' expectancy beliefs and subjective task values are assumed to be influenced by their perceptions of attitudes and expectations of others, especially parents' and teachers. Individuals' interpretations of their past performance are assumed to be influenced by socializers' beliefs and behaviors and by cultural milieu such as gender role stereotypes, cultural stereotypes of the subject matter and family demographics (Wigfield & Eccles, 2000; Eccles & Wigfield, 2002). In a study involving fourth and fifth grade students (n=71) and their parents (n=69), Dempsey and colleagues (Dempsey et al., 1993) found that parents' perception of their children's competence in doing moderate-to-vigorous physical activity (MVPA) outside school was related to children's actual participation in MVPA, while parents own physical activity behavior (role modeling) was unrelated to children's MVPA. In addition, children's expectancy beliefs significantly predicted their MVPA participation.

Xiang and her colleagues (2003) examined the relationship between parents' (n=102) achievement goals, expectancy beliefs and task values and the third and fourth grade students' (49 boys, and 53 girls) motivation in a running program. Children's motivation was operationalized as persistence/effort in the running program and was measured by the number of laps run/walked over the year-long running program. Performance was measured by the timed mile run. Results indicated that only parents' competence beliefs were predictive of their children's persistence/effort and mile run performance. Research on expectancy-value theory in physical education demonstrated that students' expectancy related beliefs and task values, intrinsic interest value in particular, are predictive of their participation, effort, and persistence in physical education. The research also indicates that the parents' competence beliefs may influence

or reflect their children's participation in MVPA (Dempsey et al., 1993) and effort in physical education (Xiang et al., 2003). However, these findings have come from limited physical activity knowledge/skill domains, Xiang et al.'s work in one running program in physical education and Dempsey's work in after school physical activity participation. Although students' achievement was measured by a timed mile run test, emphasis of the running program was on engaging students in running rather than teaching the skill of running or the strategies of learning to run. Apparently, more research is needed to expand the inquiry on the association of students' expectancy beliefs and task values with their cognitive and motor skill learning in physical education.

Interest Theory

The function of individual interest in learning in physical education is still uncertain. Chen and Shen (2004) randomly selected 104 students from two middle schools to explore the relationship among students' individual interest, physical intensity in classes, physical skill, and knowledge. Correlation analysis showed a very weak association between students' individual interest and their learning outcomes (physical intensity, physical skills, and cognitive knowledge).

Even though students' individual interest may not directly relate to learning outcomes, research did reveal a positive link between individual interest and use of learning strategies. Guided by the Model of Domain Learning (MDL, Alexander, 2005), Shen and Chen (2006) explored the interrelation among knowledge, interests, and use of learning strategies in middle school physical education. A path analysis showed a significant path from individual interest to use of learning strategies. It appears that the students with high individual interest in the content were more likely to adopt certain

learning strategies to improve their skills than students with low individual interest in the content. In other words, students who were interested in the content tended to put more efforts into learning than those who were not interested in the content.

Situational interest, on the other hand, has been assumed to have practical meaning to physical education. In general, most students are attracted to physical education and enjoy the experiences (Goodlad, 1984). Unlike individual interest, situational interest is controllable by teachers (Hidi & Baird, 1986). Based on Deci's (1992) theoretical articulation of a multi-dimensional model, Chen, Darst, and Pangrazi (1999) conducted a 4-stage, multi-sample study involving 674 middle school students to validate the construct of situational interest. Exploratory and confirmatory factor analyses suggested a five-dimension situational interest model characterized by novelty, challenge, attention demand, exploration, and instant enjoyment. More recently, in a replication study in elementary physical education, Sun, Chen, Ennis, Kim, Bolleno, Hopple, and Bae (2006) found the five-dimension situational interest model tenable with elementary students.

Situational interest is embedded in tasks and learning environments. For it to become a motivation source, the learning task should be designed carefully to become situationally interesting to the learner (Hidi & Baird, 1986; Mitchell, 1993). Physical education learning task consists of, in large part, a physical movement component and, often neglected, a cognitive component (Schmidt, 1991). How a task is designed may offer different situational interest in physical education. In a study examining the effects of different cognitive and physical demands of learning tasks on situational interest, Chen and Darst (2001) found that cognitive demand in a physical activity determines the level

of situational interest. The middle school students in the sample (n=242) considered the tasks with high cognitive demand as highly situationally interesting, regardless of the physical demands. Tasks with low cognitive and low physical demands were evaluated particularly low in situational interest.

In addition, situational interest was found to be associated with students' cognitive efforts during their learning process (Shen & Chen, 2006). More specifically, a direct, significant influence of situational interest was associated with students' use of learning strategies. Shen and Chen (2006) further reported that the association was independent of students' individual interest, suggesting that situational interest has a significant impact on students' application of learning strategies regardless of their individual interest in the content.

There is, however, very limited evidence of the relationship between situational interest and students' learning achievement. Sun et al. (2006) examined the effect of situational interest on students' learning in an elementary physical education curriculum specially designed to enhance young learners' knowledge about health-related science in physical activity. In this randomized, controlled study, cognitive knowledge was pre- and post-tested and the residual knowledge gain score was used as the learning outcome. Regression analysis indicated that challenge, one of the five dimensions in the situational interest construct, was the only meaningful predictor for students' knowledge gain. In an earlier study, Shen, Chen, Tolley, and Scrabis (2003) found no association between students' knowledge and skill acquisition and situational interest.

In physical education, individual interest is found to be related to situational interest (e.g., Chen & Darst, 2002; Shen & Chen, 2006). Chen and Darst (2002) reported

that students with high individual interest are more likely to be cognizant about situational interest than students with low individual interest. Shen and Chen (2006) also revealed a weak but significant relationship between students' individual interest and situational interest.

Summary

Extensive research on motivation has been conducted in physical education with different theoretical frameworks of achievement goals, expectancy-values, and interests. More studies are needed to clarify the relationship between students' motivation and their learning. We know that physical education teachers can manipulate the achievement goal orientation climates and situational interest in classes and help the learner recognize task values and develop their positive expectancies for success. But there is a need for more and stronger evidence relating the effort of teachers to student learning.

The findings contribute to our understanding of motivation sources and their functions in physical education in terms of student behavior, task design, and learning outcomes. Despite the difference in theoretical frameworks, the research on motivation in physical education seems to share the core idea derived from the social-cognitive tradition, which suggests perceptions developed through social interactions are the center of motivation sources (Bandura, 1986). These interactions either motivate or demotivate the learner by creating a sense about competence, defining successes, and generating interests. Research in physical education clearly has established these characteristics with the learners in the motor domain and continues to challenge researchers with the apparent lack of connection between motivation, motivated learning behavior, and learning outcomes.

One disposition is that the theories discussed above generally take a position emphasizing motivation as a process that the learner adapts to the external environments. Motivation, as an innate mental process, also should be considered as a drive residing within a person that is waiting to be called upon in situations where motivation is needed (Hidi & Harackiewicz, 2000). Thus, motivation should be viewed as a human need also. Based on this assumption, Deci and Ryan (1985, 1991, 2000) have proposed and argued for the self-determination theory in which motivation is conceptualized as basic human needs, specifically the need for competence, relatedness, and autonomy. The extent to which the three innate needs are fulfilled determines human beings' level of motivation and their behaviors (Deci & Ryan, 2000). This perspective may enable us to understand motivation as a process that an individual internalizes and personalizes environmental influences into the development of the three needs. I will discuss the self-determination theory below.

Self-Determination Theory (SDT)

Overview of Self-Determination Theory

Self-determination theory (SDT) explains human motivation, by focusing on the importance of human inner resources for development and behavioral regulation (Ryan & Deci, 2000a). In this theory, human beings are assumed to be active in nature and have natural and innate tendencies to develop a unified sense of self (Deci & Ryan, 1985; Ryan & Deci, 2002). Based on this fundamental assumption, SDT postulates that the desire to meet one's innate needs is the fundamental motive for human behavior; but the motivation cannot be taken for granted because the environmental factors can either encourage or thwart the innate tendency to act to satisfy the needs (Ryan & Deci, 2002a).

The Basic Innate Needs

According to Deci and Ryan (1985), a unique characteristic of STD is its recognition of the function of human innate needs, a fundamental source of mental energy for human behaviors often manifested in a person-activity interaction in an environment, such as a classroom, a gymnasium, or a playground. In SDT (Deci & Ryan, 1985), needs for competence, autonomy, and relatedness serve as the cornerstones of human motivation. These needs set human motivation apart from those that are shared by human beings and other living species, such as the needs for food, shelter. Specifically in SDT, *Competence* refers to satisfaction in ones' ability and feeling effective in an ongoing activity (Deci & Ryan, 1985). The more competent a person perceives him/herself in the activity; the more intrinsically motivated one will be for that activity (Deci & Ryan, 1985). *Autonomy* is the degree to which an individual perceives her/himself as the origin or source of a behavior and as being responsible for the initiation of the behavior (Ryan & Deci, 2002). When experiencing autonomy, an individual regulates his/her own behavior by governing the initiation and direction of actions (Ryan & Powlson, 1991). *Relatedness* is defined as the extent to which an individual feels connected to others through the activity and their senses of belongingness both with one's community and with other individuals (Ryan & Deci, 2000a).

Deci and Ryan (e.g., 1985, 2000) conceptualized SDT as a motivation process in which an individual self-regulates his/her action dependent on the degree of his/her needs satisfaction. This process is characterized by six major related components whose motivational functions vary in terms of individuals' need satisfaction and the person-environment interaction as well as the outcome of the interaction. SDT proposes a self-

regulation continuum. Figure 2.2 presents a visual representation to indicate different types of motivation with their regulatory style. *Amotivation* is at the far left side and intrinsic motivation is at the far right side of the self-regulation continuum. *External regulation, introjected regulation, identified regulation, and integrated regulation* are positioned between amotivation and intrinsic motivation. I will explain these components and their theoretical relationships in detail.

Figure 2.2 The Self-determination Continuum (Ryan & Deci, 2000a).

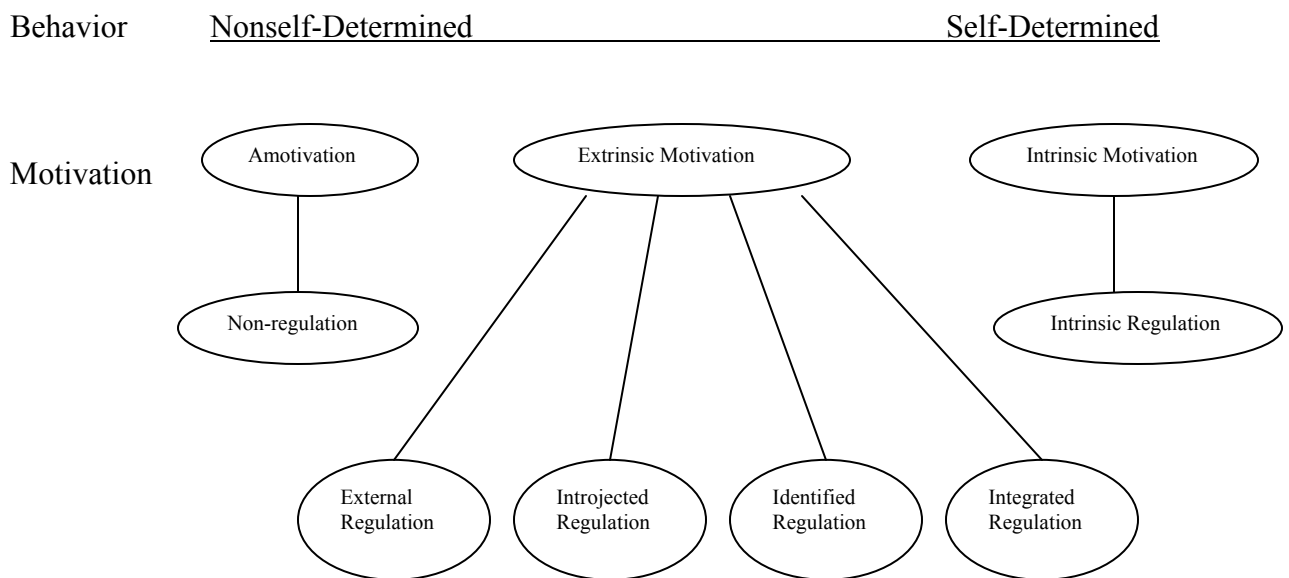

Intrinsic Motivation, Extrinsic Motivation, and Amotivation

In SDT, motivation can be understood in three basic states, intrinsic motivation, extrinsic motivation, and amotivation. *Intrinsic motivation* indicates that individuals engage in an activity for the sake of the activity itself and for the satisfaction inherent in performing the activity (Deci & Ryan, 1985). Intrinsic motivation often derives from the person-activity interaction in activities that people find interesting, optimally challenging, or aesthetically pleasing (Ryan & Deci, 2002). In other words, intrinsic motivation energizes a wide variety of behaviors and the primary rewards for performing these

behaviors are the experiences of autonomy, competence, and relatedness (Deci & Ryan, 1985). Therefore, intrinsic motivation resides in people's needs of autonomy, competence, and relatedness and is considered the fuel for action to satisfy one's innate needs (Grolnick, Gurland, Jacob, & Decourcey, 2001).

In reality, however, people often *need* to be motivated extrinsically, because not all human activities are intrinsically interesting to everyone, equally optimally challenging to all, and aesthetically pleasing. Many activities or tasks in the school and the contemporary society likely lack intrinsic motivation characteristics, but they deemed necessary for people to engage in. Thus people often *need* to be motivated through the means other than interest, challenge, and pleasant experiences. Motivation that derived from the means that lead to enhanced performance in activities of low interest, low challenge, and little pleasant experiences is often referred to as *Extrinsic Motivation* (Deci & Ryan, 1985). From this perspective, SDT explains how non-intrinsically motivated individuals become motivated to carry out activities necessary for them at the current stage of life and how extrinsic motivation affects ongoing activities and can be internalized (transformed) in association with the innate needs (Ryan & Deci, 2000b).

In addition, the absence of motivation, which refers to situations where an individual lacks the intention to act (Ryan & Deci, 2000a), is named *amotivation* in SDT. Amotivation occurs when an individual feels incompetent or helpless to perform an activity, does not value the activity or expect the activity to yield a desired outcome, or feels lack of control in an environment (Deci & Ryan, 1985; Ryan & Deci, 2000a). When an individual is amotivated, he/she either does not take part in the activity at all or just goes through the motions without intent (Ryan & Deci, 2000a).

The Motivation Regulation Processes

The different types of motivation reflect differing degrees to which the value of the required behavior in an activity has been internalized and integrated by the individual. According to SDT, *self-regulation* is “the energization and guidance of behavior on the basis of integrated awareness, informed by basic needs” (Ryan & Deci, 2000c, p. 47). A true self-regulation behavior, as stated by Ryan and Deci (2000c), represents the integrated acceptance of an activity by considering in terms of individuals’ needs, values, and judgments. A self-regulatory process is the process by which individuals regulate the extrinsic motivation into more self-determined motivation. This is the process of internalization and integration (e.g., Deci & Ryan, 1985; Ryan & Deci, 2000a, 2000b). In other words, individuals internalize and integrate external values and behavioral regulations into their own.

Extrinsically motivated behaviors do not occur spontaneously out of the characteristics of a task or activity and they require the provision of external factors if they have to occur (Deci & Ryan, 1985). The external factors function to impose an externally controlled regulation to the individual to bring about and reinforce the desired behavior. Because many extrinsic contingency mechanisms (including rewards) may have detrimental effects on intrinsic motivation (Deci et al., 1999), what types of external control and how to use external controls to regulate behavior without decreasing intrinsic motivation have become central to SDT (Deci & Ryan, 1985) and related research. Deci and Ryan (1985) argued that there must be a process of internalization through which an individual gradually acquires the value or belief central to the external regulation mechanism (along with its necessary extrinsic contingencies) and transforms it into a

personal belief based on which the individual regulates the behavior in the similar environment, such as in schools. Transforming an external regulation mechanism into an internal one requires a shift of personal value from a personal-centered perspective to the external controlled perspective.

Internalization is a constructive process that involves resolving the inherent conflict between autonomy (what one would do naturally) and external control (what one is being asked to do) (Deci & Ryan, 1985). The process consists of four types of behavioral regulations of extrinsic motivation. Based on different degrees of autonomy and external control involved in the process, these behavior regulation mechanisms are named as in Figure 2.2: *External regulation*, *Inrojected regulation*, *Identified regulation*, and *Integrated regulation* (e.g., Deci & Ryan, 1985). Below is a short summary of these regulations.

External regulation. This is the most basic form of regulation that an individual adopts in order to satisfy an external demand or reward contingency (Ryan & Deci, 2000b). This regulation occurs when one is anticipating a certain outcome associated with the required behaviors. For example, a student may participate in a running program because he/she will be rewarded for participation (e.g., a T-shirt or hat), despite the fact that the student does not like running. In this case, the behavior (participation) is regulated through extrinsic rewards and may be sustained through the student's internalization of anticipation to receive a reward. The running behavior, thus, is self-regulated by the externally imposed consequence that is anticipated (Deci & Ryan, 1985). This type of regulation relies entirely on external control, rather than autonomy.

Introjected regulation. Introjection refers to partial or suboptimal internalization in which the individual does not fully identify with the value or regulatory process and does not accept it as his/her own. (Deci, Eghrari, Patrick, & Leone, 1994). But the individual regulates his/her own behavior to comply with the behavioral expectation because he/she feels having to rather than wanting to (Deci & Ryan, 1985). In this type of regulation, a behavior may be self-initiated under external pressure and tension, the behavior is often accompanied by anxiety (Deci et al., 1994). The introjected regulation is considered present in behaviors conducted in order to avoid a sense of guilt or to attain and maintain ego enhancement such as pride (Deci & Ryan, 1985). For instance, a student participates in running to avoid a feeling of guilt for not engaging in class activities. In the introjected regulation, individuals have established an internal version of the external contingence and may behave without contingent rewards. Thereby, one demonstrates a degree of autonomy, which, nevertheless, is operating on externally regulated motive (Deci & Ryan, 1985).

Identified regulation. A more self-determined form of extrinsic motivation is identified regulation, which means regulation through personal identification with the desired behavior. Identification reflects the fact that regulation has been accepted as personally important (Ryan & Deci, 2000b). An individual with identified regulation demonstrates more autonomy and self-determination as he/she has accepted the form of regulation as their own through identifying self with the regulation process. For example, a student participates in running because he/she understands and believes running to be beneficial to his/her health. In other words, the student identifies participation in running as part of him/her-self in seeking optimal health. A unique characteristic in this regulation

is autonomy; rather than the external influences/regulations such as those from significant others (e.g., teachers, parents). The individual with identified regulation does not identify with external influences, but rather with the values of the activity. The individual values the outcome the activity itself provides, rather than those unrelated to it (e.g., T-shirts as rewards), and acknowledges the importance of the behavior in terms of the outcome. In this process, the conflict between autonomy and external control is largely dissipated and the individual experiences less pressure and more flexibility in regulating the desired behavior.

Integrated regulation. Integration refers to optimal internalization resulting in self-determination and is necessary for controlled behaviors to become autonomous (Deci et al., 1994; William & Deci, 1996). Integrated self-regulation is the most self-determined form of extrinsic motivation. It allows the individual to evaluate the identified regulations and bring the values of the regulation into congruence with one's other values and needs for life (Deci & Ryan, 1985). Individuals with integrated regulation do not only do what they are required to do, but also display the external values while engaged in the desired behavior that they have accepted as their own. Take running for instance, students with integrated regulation believe in the values the teacher has conveyed to them in running. They become not only active runners in physical education, but also adopt the behavior in their lives outside physical education. In the integrated self-regulation, external contingences, significant others' authority, or affective factors such as pressure, sense of guilt, or shame would not determine individuals' behavior. It is the choice decisions derived from interpreting the external values that determine one's motivation and behavior (Deci & Ryan, 1985). Even though this type of regulation shares many qualities

with intrinsic motivation, it is still considered as extrinsic because the purpose of the desired (or regulated) behavior is to attain separable outcomes independent from the activity (such as good health, rather than interest or enjoyment of running, if referring to the running example).

SDT in Education

In this section, I will review research studies guided by SDT in education and physical education. My specific focus is on examining and critiquing the studies on (a) the three basic innate needs as well as the impact of basic need satisfaction on motivation and learning; (b) factors that either facilitate or thwart intrinsic motivation in relation to learning behaviors and learning outcomes; (c) the regulatory processes in relation to learning behaviors or outcomes, and (d) functions of learning and behavior change in physical education and physical activity.

Basic needs and learning environment. Deci and Ryan (1985; Ryan & Deci, 2000a) argued that social contexts provide people the opportunity to satisfy their basic need for competence, relatedness, and autonomy. Although self-determination is an individual-centered process, its development depends on a supportive environment, especially for school-age children. Based on this theoretical postulation, a number of studies in the laboratory and field have been conducted to examine how students' needs of competence, relatedness, and autonomy can be affected by the social context, and how satisfaction of the need influences motivation development and performance on various tasks (e.g., Black & Deci, 2000; Miserandino, 1996; Reeve, Nix, & Hamm, 2003; Ryan & Connell, 1989; Williams & Deci, 1996).

Autonomy. Research has found that instructor's support for autonomy predicts students' self-determined motivation, perceived competence, learning, and other positive outcomes such as less course-related anxiety and more values of the course. For example, in an early study examining students' reasons for action, Ryan and Connell (1989) found that students experiencing more autonomy in spontaneous or nondirected learning conditions were more likely to retain rote knowledge over time than students in a control condition.

More recently, Black and Deci (2000) examined the effects of instructors' support for autonomy and students' motivation on learning organic chemistry. They hypothesized that instructors who were perceived by their students to be more autonomy-supportive would lead to greater perceived competence and less course-related anxiety and grade orientation. In addition, an autonomy-supportive climate would be predictive of students' more self-determined motivation. Students ($n=137$) at a small, eastern university were randomly assigned to 42 workshop groups with 42 group leaders. The workshop leaders received some training in how to support their students in terms of supporting autonomy. Such training included facilitating problem solving, providing peer interaction and support, and creative active engagement in the learning. Students were assessed during the week prior to the first exam and two weeks before the final exam. The regression analysis suggested that students' perception of group leaders' autonomy support lead to significant increases in self-determined motivation in learning organic chemistry. In addition, leaders' autonomy support explained significant increases in students' perceived competence and interest/enjoyment and significant decrease in course-related anxiety.

Furthermore, the findings indicated that students who perceived more autonomy support from their leaders performed better in the course examinations.

Competence. Within SDT, the need for competence is “reflected in the propensity to pursue challenges that are just beyond one’s current level of functioning and through such activity to both make developmental gains and derive a sense of confidence and self-esteem.” (Ryan & Powelson, 1991, p. 53). Connell (1991) indicated that competence can be facilitated by providing structures, such as the communication of realistic expectations, consistent consequences, and competence-relevant feedback. Research has shown that experiencing an unfulfillment of the need for competence is associated with negative motivational and behavioral outcomes. For instance, Miserandino (1996) reported that when their need of competence was perceived as unfulfilled, a group of students with above-average SAT scores demonstrated negative affect and withdrawal behaviors as well as a decline in performance. The students reported less involvement in and persistence on tasks and the feeling of boredom and a lack of curiosity. In contrast, students whose need for competence was met in their social context were able to adjust to and maintain positive beliefs about their own competence, and were able to improve their grades over the school year.

Relatedness. The need for relatedness is the need for feeling securely connected to others and feeling capable and worthy of love and respect from others (Connell & Wellborn, 1991). A sense of relatedness develops from the involvement of others in the context through communication of interest in and enjoyment of the individual (Connell, 1991; Connell & Wellborn, 1991). In the education context, the need for relatedness helps in the process of cultural transmission and internalization of values often observed

between parents and children, teachers and students, and students and students (Ryan & Powelson, 1996). Research on relatedness has demonstrated that students' interaction and relationship with their parents, teachers, and peers are related to their school adjustment including academic performance, motivation, and interest (e.g., Feldman & Wentzel, 1990; Wetzel, 1999; Wentzel, 2002; Wentzel & Watkins, 2002).

Wentzel (1997) examined the role of students' perceived caring from teachers in their motivation with 8th grade students ($n=375$) in a suburban middle school. The results showed that students' perception of their teachers' pedagogical caring was moderately related to students' pursuit of social goals ($r=.45$, $p<.05$) and to their academic effort ($r=.36$, $p<.05$). The regression analysis indicated that perceived caring from teachers was a significant predictor for students' pursuit of social goals ($R^2=.09$) and academic effort ($R^2=.07$). In addition, peer relationships were also found to be associated with students' academic outcomes. Wentzel (2002) explained that students who perceived their peers as being supportive and caring were more likely to engage in positive aspect of school life, to pursue academic and social goals, and to earn higher grades than students who did not perceive such positive peer relationship.

Intrinsic Motivation

Intrinsic motivation is defined as the drive to engage in an activity for the activity's inherent interest or enjoyment rather than for outcomes external to the activity (Ryan & Deci, 2000b). An intrinsically motivated person engages in an activity to experience interest and enjoyment in the interaction with the activity rather than external pressures or rewards received during or after the interaction. The notion that intrinsic motivation can result in adaptive cognitive, affective, and behavioral outcomes has been

widely documented in research studies and broadly acknowledged by educators. For example, Ryan and Deci (2000a) conclude that intrinsically motivated students demonstrate better school adjustment than students who are not intrinsically motivated. Intrinsically motivated students demonstrate better performances, better engagement, higher quality learning behavior, and a lower drop out rate. Because of the important role of intrinsic motivation in students' learning, it is reasonable to assume that positive learning-related behaviors will be adapted and students' learning will be enhanced if students are intrinsically motivated.

It is equally reasonable to assume, however, that the development of intrinsic motivation is dependent on regulation mechanisms I mentioned above. Rarely will a student become intrinsically motivated by all school activities. For example, students may work on homework not because homework is fun, interesting, or enjoyable to them, but because they want good grades, or praise from their teachers, or to avoid negative academic consequences. Take exercise for another example, people often exercise for the purpose of losing or controlling weight rather than for the enjoyment of the exercises. These examples demonstrate the possibility that the motivation behind these activities is extrinsic and may well be dependent upon external rewards (good grades, praise, weight loss, etc.).

Conceptualized relations between social environment and intrinsic motivation.

According to SDT, intrinsic motivation derives from the activity, but resides within an individual during the person-activity interaction. Thus, it is believed in SDT that the external social environment can either facilitate or undermine intrinsic motivation. In general, a social environment can be autonomy-supportive or externally controlling. The

school/classroom environment that satisfies students' needs for autonomy will enhance or facilitate their intrinsic motivation. In education, the above theories are materialized into the way that a learning environment should be constructed. The focal point in most empirical inquiries has been whether the use of reward to control (or motivate) learning behavior would enhance or impair learner intrinsic motivation. A number of studies have been conducted on a similar scenario: whether a learner remains intrinsically motivated when a reward he/she has become accustomed to receiving after completing a task is withdrawn. Below I use two meta-analysis studies to demonstrate the inconclusiveness of research findings on advantages and disadvantages of using extrinsic motivation contingencies (such as tangible rewards) and the need to study externally regulated motivation strategies in terms of intrinsic motivation and learning outcomes.

Deci and Ryan: External rewards are detrimental. Deci, Koestner and Ryan's (1999) conducted a meta-analysis on findings from 128 studies published between 1971 and 1996. They systematically differentiated the reward conditions and calculated the effects of all rewards on intrinsic motivation. Reward conditions were conceptualized into two categories: intangible (verbal encouragement, praises) and tangible (forms of material-based reward, stickers, money, etc.). The conditions were further classified in terms of the reason a reward is given, including task-noncontingent rewards, task-contingent rewards, and performance-contingent rewards. Specifically, task-noncontingent rewards refer to the rewards that are given without requiring engagement in the target activity. Task-contingent rewards are rewards given for performing or completing the target task. Performance-contingent rewards are given for successfully performing a specific activity, meeting a certain standard or criterion. Task-contingent

rewards were further conceptualized into completion-contingent rewards and engagement-contingent rewards. Completion-contingent rewards are given for completing the target activity and engagement-contingent rewards are given for engaging in the task but do not require task completion.

The results of a systematic analysis of the research findings support a notion that different types of reward have different effects on intrinsic motivation. But in general, Deci et al. (1999) revealed that overall, intangible rewards (e.g., positive verbal feedback) enhance intrinsic motivation, whereas tangible rewards undermine it with the exception when tangible rewards are given unexpectedly (without rewardee's prior knowledge). Rewards that are disconnected from task engagement (task-noncontingent rewards) have neither positive nor negative effect on intrinsic motivation. Rewards tied to task-, performance-contingency are detrimental to intrinsic motivation. In other words, if a learner receives a reward as a direct function of their performance on or engagement in learning activities, the possibility of being motivated by the activities decreases when the reward is no longer available.

Cameron and Pierce: External rewards are useful. Cameron and Pierce (1994), on the other hand, arrived at a different conclusion after conducting a meta-analysis study on the same issue. Their study included 96 experimental studies and the effect size was calculated to determine the effect of external rewards on intrinsic motivation. Consistent with Deci et al. (1999) findings, positive verbal reward and unexpected tangible rewards were not detrimental to intrinsic motivation. Contrary to Deci et al. (1999), however, Cameron and Pierce did not find detrimental effects from other forms of external rewards, except task-engagement-contingent reward, on intrinsic motivation. The findings imply

that the learner receiving unexpected or expected tangible reward for performing well in a learning task is unlikely to become unmotivated when the rewards are withdrawn. Based on their evidence, therefore, Cameron and Pierce (1994) argued that a controlling environment such as using rewards may not lead to negative results with respect to intrinsic motivation.

Research on extrinsic- and intrinsic motivation and on external conditioning of intrinsic motivation has provided strong support to the notion that in a social environment such as schools, classrooms, or gymnasias, intrinsic motivation will inevitably be influenced by social factors. The debate is important in that it reveals that positive or negative feedback from teachers, peer students, or parents, stickers for participation in an activity, or award certificates for a successful performance can all have external regulatory impact on intrinsic motivation, one way or the other. Thus, it has become extremely important to understand the process of regulations and their impact on learner self-determined/regulated motivation.

Moreover, Chandler & Connell (1987) reported that there is a developmental movement from the nonregulation of behaviors that do not interest one, toward self-determined regulation of the behaviors that are useful for one's effective adaptation. Although it seems that the four types of self regulation form a conceptual continuum toward the development of self-determination for extrinsically motivated behavior, Deci and Ryan (2000) indicate that it may not be the case. Instead, they suggest that individuals can readily internalize new behavior regulation with any type of self regulation, depending on both prior experiences and current environmental factors.

SDT in Physical Education

SDT Model Test. Even though self-determination theory has been gaining recognition in educational research, it is not until recent that SDT has been applied in research in physical education (Standage et al., 2005). A hierarchical motivation model (Vallerand & Losier, 1999; Vallerand & Rousseau, 2001; Ryan & Deci, 2000a) incorporating the fundamental tenets of SDT has been used to examine SDT in physical education. Of particular interest to this hierarchical model is the sequential pattern of motivational processes: “social environments → innate need satisfaction → types of motivation → consequences”. More specifically, this model is used to examine (a) how students’ perceptions of their social environments in terms of three innate need support will influence their innate need satisfaction, (b) how students’ need satisfaction, in turn, will affect their motivations toward physical education, and (c) the affective, behavioral or cognitive consequences associated with their motivations in physical education.

Based on this fundamental model, Ntoumains (2001, 2005) developed several alternative models and tested them using structural equation modeling (SEM) analysis. In these studies, the three basic needs of students (competence, relatedness, and autonomy) and social environmental factors supporting the needs are conceptualized separately as three need support variables and three need satisfaction variables and were studied as separate entities in the structural model (Ntoumains, 2001). Recently, (Ntoumains, 2005) the three need support variables were combined to represent a higher level latent variable of “need support”. He used the three need satisfaction variables were used to represent a single latent variable of “need satisfaction”. Results from these studies suggested that the

both conceptualized models are tenable in physical education because the alternative models tap into theoretically hypothesized causal relationships to explain the SDT motivation process (Standage et al., 2005). In the following sections, I will review SDT studies in physical education and discuss important theoretical underpinnings for my dissertation study, namely constructivist learning contexts, intrinsic and extrinsic motivation issues, and student learning outcomes.

SDT and constructivist contexts. Oldfather and Dahl (1994) argued that motivation is not something that teachers do for students; instead, motivation should come out of students' natural inclinations as self-determining human beings. Consistent with this argument, SDT researchers are focusing on the issue of how social contexts or environments can fulfill students' innate needs to become self-determining and how satisfying these needs can result in their motivation. Oldfather and Dahl (1994) argue that to fully understand learner's motivation from the SDT perspective, one should adopt a social constructivist view of learning that values the reciprocal relationship between the learner and the social context as much as the interaction between the learner and the knowledgeable others (Vygotsky, 1978).

To study SDT in relation with learning context in physical education, exercise psychologists have incorporated the achievement goal orientation theory in research where students SDT and perceived learning climates (mastery, performance, and original) are studied together (Ntoumanis, 2001, 2005; Standage et al., 2005). More specifically, the researchers articulated three physical education learning climates. A mastery-oriented climate indicated a student perception of a context with an emphasis on task/mastery goals. A performance orientated climate indicated a student perception of a focus on

ego/performance goals. An origin climate meant the degree of which students perceived a climate of autonomy support rather than controlling.

In physical education, Ntoumanis's (2001, 2005) hypothesized that a mastery environment characterized by cooperation, self-referenced improvement, and opportunities to make choice decisions would satisfy the needs for relatedness, competence, and autonomy, respectively. The SEM on the responses from 424 British middle school students indicated strong relationships between the mastery context with the three social factors of cooperation, improvement, and choice, and the satisfaction of the three innate needs of relatedness, competence, and autonomy. Despite the encouraging relationship, students ratings on choice and autonomy measures were below the center point of 3 on the 5-point scale (mean = 2.43, 2.75, respectively, 5 is the highest).

Ntoumanis (2001) attributed the low autonomy as the outcome of the British mandatory national curriculum where students are given few opportunities to experience choices and leadership roles in learning. He also speculated that the results are reflective of physical education teachers' unwillingness to provide choice and foster autonomy. From a curriculum perspective, the findings and the researcher's speculation indicate a need for adopting the constructivist curricular approach that may better meet students' SDT needs in physical education. From a social constructivist perspective, learners are actively constructing meanings and understandings about what they are interacting with in physical education.

In assessing students' need satisfaction in the mastery-, performance-, and origin climates, Standage, Duda, and Ntoumanis (2003a) hypothesized that a mastery climate

and an origin climate would fulfill students' three innate needs, and a performance climate would negatively relate to relatedness and autonomy and be unrelated to competence due to its controlling characteristics.

An SEM analysis revealed that the autonomy-supportive environment (origin climate) contributed to student need satisfaction of autonomy, competence, and relatedness. The performance climate was not related to student perceived autonomy and relatedness. In addition, the mastery climate was found only to contribute to autonomy, not to relatedness or competence. Standage et al. (2003a) attributed the departure from the theoretical postulations and the research hypothesis to the lack of a cooperative learning subscale in the instrument (the English version of Perception of Climate Motivation; (EPCM), Biddle et al., 1995) used to measure the mastery climate. However, Ntoumains (2001) found that student perceptions of teacher's emphasis on individual/personal improvement did predict perception of competence. Based on this finding (Ntoumains, 2001), at least a path between the mastery climate and student perceived competence would be expected even if the EPCM was used. Therefore, the use of EPCM may not be the only factor that causes the lack of meaningful connections between the mastery climate and students' need satisfaction of competence or relatedness.

These findings suggest that creating a mastery climate alone may be limited in fulfilling students' three innate needs. Indirectly, the findings support the point of view from the social constructivist perspective that an effective learning environment should not only emphasize creating a social-interaction context to help learners master the knowledge, but also empowering students as constructors of shared meanings or knowledge in the learning process. In this environment, learners become the owners of

learning and are able to identify themselves with the learning process through preferred ways of learning to achieve (Pollard, Thiessen, & Filer, 1997).

SDT and intrinsic and extrinsic motivation in physical education. Satisfying the innate needs for autonomy, competence, and relatedness can lead to enhanced self-determined motivation in physical education. An overall satisfaction of three needs was found to positively predict students' intrinsic motivation and introjected motivation (Ntoumanis, 2005; Standage et al., 2005), suggesting that an environment supporting students' innate needs helps develop self-determined motivation. The external regulation is negatively associated with the satisfaction of the needs and leads to amotivation (Standage et al., 2005), indicating the environment with strong teacher dictation and limited student choices demotivate students in physical education.

Of the most significance is that satisfaction of the needs leads to enhanced student motivation for future participation in physical education. Ntoumanis (2005) compared perceptions of social support and need satisfaction in prior compulsory physical education experiences (n=302) between students who chose optional PE and those who did not. Ntoumanis (2005) measured perceptions of social support and the need satisfaction when the students were in the compulsory PE classes and measured their participation in optional physical education classes the next year when the students had made decisions for the optional physical education classes. The results revealed that those choosing the optional physical education, reported significantly greater competence, relatedness, and autonomy need satisfaction in the compulsory physical education compared with those who did not. In addition, they were more self-determined in the compulsory physical education, compared with the nonparticipants.

Although research has revealed that an overall need satisfaction can lead to more self-determined motivation, it is still not clear about the contribution of satisfying each innate need to students' motivation. Research findings (Table 2.1) about the individual innate need's contribution are quite inconclusive. For example, while it has been reported that students' perceived competence is positively related to identified regulation and introjected regulation (Ntoumanis, 2001) and may predict intrinsic motivation (Ntoumanis, 2001; Standage et al., 2003b), autonomy has been found to make little contribution to types of regulated motivation (Ntoumanis, 2001). However, Standage and colleagues (2003b) reported autonomy to be a positive predictor of self-determined motivation and introjected regulation while competence did not predict introjected regulation. Students' perceived autonomy has also been shown to predict students' intrinsic motivation and identified regulation in physical education in other studies (Hagger, Chatzisarantis, Culverhouse, & Biddle, 2003; Hagger, Chatzisarantis, Barkoukis, & Wang, 2005). Moreover, Gouda and Biddle (1994) suggested that perceived competence is related to intrinsic motivation only when the context is associated with autonomy support. They indicated that perceived autonomy might be a more critical factor for intrinsic motivation than perceived competence, which suggested that individuals may not be intrinsically motivated when engaged in activities in a context controlled by others such as teachers, no matter how competent they feel. Gouda and Biddle's (1994) findings seem to be consistent with the notion of SDT (Ryan & Deci, 2000a) that a learning context supportive of learner autonomy is a necessary condition for the association between perceived competence and intrinsic motivation.

The need for relatedness, a variable reflecting the degree of social interaction in learning, has been reported to be a weak, though positive, predictor for intrinsic motivation, identified regulation, and introjected regulation (Ntoumanis, 2001; Standage, Duda, & Ntoumanis, 2003a).

Table 2.1 Research regarding need satisfaction and motivation

	Amotivation	External regulation	Introjected regulation	Identified regulation	Intrinsic motivation
Autonomy			Standage et al., 2003b;	Standage et al., 2003b; Hagger, Chatzisarantis, Culverhouse, & Biddle, 2003; Hagger. Chatzisarantis, Barkoukis, & Wang, 2005	Standage et al., 2003b; Hagger, Chatzisarantis, Culverhouse, & Biddle, 2003; Hagger. Chatzisarantis, Barkoukis, & Wang, 2005
Competence	Ntoumanis, 2001	Ntoumanis, 2001	Ntoumanis, 2001	Ntoumanis, 2001	Ntoumanis, 2001; Standage et al., 2003b
Relatedness			Ntoumanis, 2001; Standage et al., 2003b	Ntoumanis, 2001; Standage et al., 2003b	Ntoumanis, 2001; Standage et al., 2003b

In summary, it is clear that a collective satisfaction of the three innate needs can lead to self-determined motivation in physical education. However, the independent contribution of satisfying each individual need for motivation is not clearly articulated in physical education. Thus, the findings are limited in guiding the development of a motivating curriculum through providing a holistic framework in which each need can function to make unique contribution to learner motivation. SDT findings in physical education, especially those with achievement goal climate variables, seem to support a

constructivist approach to curriculum and instruction. It is important, then, to clarify the individual contribution of satisfying each innate need for teachers to create a constructivist learning environment conducive to optimal learner motivation and achievement. For example, the relatedness need should be critical to motivation and learning from a social constructivist point of view. The absence of its function from the current research findings does not seem to give a clear guidance about the extent to which the need for relatedness contributes to learner motivation and learning.

SDT and learning. Learning in physical education is defined as a relatively permanent behavioral change resulting from experience of physical movement associated with cognitive understanding of the movement (Rink, 2001). Learning in physical education can be represented by student performance on achievement tests of cognitive knowledge and skills and reflected in terms of in-class physiological intensity (Chen & Ennis, 2004).

Cognitive knowledge and motor skill acquisition are the central indicators of student learning in physical education. Within the hierarchical model of “social environments → innate need satisfaction → types of motivation → consequences”, therefore, learning outcomes should be included in the consequences part of the model. However, in most studies, knowledge and skill acquisition is not built in the consequences part of the models examined. In these studies, the consequences parts of the models were often defined in terms of students’ concentration level (Ntoumanis, 2005; Standage, et al., 2005), preference to attempt challenging tasks, positive affect (i.e., happy, satisfied, excited, and relaxed) (Standage, et al., 2005) and negative affect (e.g., disappointed, embarrassed, boredom) (Standage, et al., 2005, Ntoumanis, 2001),

intention of being physically active after school (Ntoumanis, 2001, 2005; Standage, et al., 2003b), and effort in PE (Ntoumanis, 2001). Students' affection, effort, concentration in physical education and intention toward after school physical education can also be considered as important components in physical education. Understanding these factors can help educators and practitioners better facilitate students' learning. In addition, the relations between these variables and students' motivation revealed in the previous section also call for the further study on measuring learning outcomes such as knowledge or skill acquirement. Therefore, despite the absence of learning outcomes in the model, it is still worth discussing how students' motivation, influenced by their innate need satisfaction, will relate to the above consequences. I will review these results in the following.

According to SDT, intrinsic motivation is defined as the drive to engage in an activity for the activity's inherent interest or enjoyment rather than for outcomes external to the activity (Ryan & Deci, 2000b). Intrinsic motivation has been considered an important motivator of learning. In physical education, research has shown that intrinsic motivation positively predicted students' concentration level (Ntoumanis, 2005; Standage, et al., 2005), preference to attempt challenging tasks, positive affect (i.e., happy, satisfied, excited, and relaxed) (Standage, et al., 2005), intention of being physically active after school (Ntoumanis, 2001, 2005; Standage, et al., 2003b), and effort in PE (Ntoumanis, 2001) and negatively predicted negative affect (e.g., disappointed, embarrassed) (Ntoumanis, 2005). In addition, students' intrinsic motivation in compulsory physical education had significant effects on their participation in optional physical education (Ntoumanis, 2005).

Extrinsic motivation through self-regulation is needed to counter the decline of intrinsic motivation associated with growing and development of children (Guthrie, Wigfield, & VonSecker, 2000). It is also needed due to the fact that stated that there are many values, behaviors, or events that do not naturally interest students but the society in which they live deems necessary for them to learn (Deci & Ryan, 1985). Therefore, the interest of SDT is in the processes through which one becomes to value and self-regulate behaviors that are not initially interesting or spontaneous.

Very few studies have directly examined the construct of identified regulation in physical education. The role of identified regulation in students' cognition and affection remains unclear. Research revealed that identified regulation did not predict effort, intention for future physical activity participation or boredom in PE (Ntoumanis, 2001). Such results, however, were considered surprising because identified regulation is expected leading to a more self-determined motivation. Students with a high level of identified regulation should report the importance of developing sport skills (Ntoumanis, 2001).

Introjected regulation did not predict any motivational, affective, or behavioral outcome in physical education, such as effort, boredom (Ntoumanis, 2001), intention (Ntoumanis, 2001; Standage et al., 2003b), concentration, positive affect, challenging task preference, or negative affect (Standage et al., 2005). Presumably, the lack of a link between introjected regulation and cognitive and affective consequences in physical education may indicate that teachers need to create socially supportive environments to fulfill students' innate needs and help them internalize external regulation into their own. In the introjected regulation, students become better able to control their learning

behavior as a result of internalizing a previously established external control (such as teacher's disciplinary rules). During the introjected regulation, students are establishing an internal representation of the external controls (Deci & Ryan, 1985; Ryan & Deci, 2000) and become more likely to engage in an activity without external contingencies, such as rewards, and to better monitor their behaviors. However, students' ability to engage, monitor, and regulate is not stable due to the fact that introjected regulated students are facing conflicting impulses (i.e., to perform or not to perform). To facilitate the internalization process for optimal motivation, the teacher should provide social support to the students (Deci & Ryan, 1985; Ryan & Deci, 2000). A socially constructive environment enhances social interactions, promotes a sense of belongingness, and stabilizes the relatedness in the classroom. The environment encourages students to internalize the values and behaviors during learning.

Despite the theoretical hypotheses that external regulation would lead to maladaptive affective or undesirable cognitive consequences, no relationship, positive or negative, has been established between external regulation with effort in class, intention for after school physical activity (Ntoumanis, 2001), concentration level, and preferences for challenging tasks in PE (Standage et al., 2005). These findings, at least, suggest that external regulation does not yield adaptive outcomes in PE. It does, however, predict students' feeling of boredom in physical education (Ntoumanis, 2001), suggesting an association between strong teacher control and increased boredom.

From a learning-centered perspective, motivation should be "linked explicitly to ways of knowing, understanding, and constructing meaning" (Oldfather & Dahl, 1994, p.139). Motivation enables students to actively negotiate meanings to be constructed

within the unique classroom culture (Thomas & Oldfather, 1997). In physical education, students learn to become physically active people through actively constructing knowledge, skill, values, norms, and regulations necessary for participation in physical education and benefiting from being knowledgeable, fit, and skillful. More importantly, motivation should lead students to self-determination that helps construct a sense of self and identity as active learners in physical education.

As a school subject, physical education has emphasized the development of a healthy, physically active lifestyle. Accordingly, students must master a body of disciplinary knowledge that integrates biological-medical sciences, social-psychological sciences, and cultural humanities in order to achieve the goal of becoming physically educated (Chen & Ennis, 2004). It has been widely accepted that motivation plays important roles in students' learning. Given physical education is an environment that students physically move in order to learn, the external control imposed by the teacher can be very evident. SDT is, then, a viable theoretical basis for us to look into the complex interaction among learning environment, curriculum/ task, motivation, and learning.

Changes of Achievement Motivation: A Developmental Perspective

Students' motivation changes as they go through their school years. Developmentally, as they grow up, students' understanding of motivational constructs includes more dimensions; the sources of motivation become more complex; the levels of their motivation become more sophisticated; and their motivational values, beliefs, and goals become more and more influential on their choice and performance in the academic activities (Wigfield & Eccles, 2002). Specifically, students' achievement goal

orientations change in a variety of way throughout elementary school, middle school, high school, and college (Anderman, Austin, & Johnson, 2002). As they progress through school years, students' tend to become more adaptive to performance goals, but less to mastery goals. Such changes is particular apparent during the transition from elementary to middle school (Anderman & Anderman, 1992). However, how and why students' social goals develop has not been well understood (Wentzel, 2002).

With respect to students' expectancy beliefs and values, research has shown that the levels of students' competence-related beliefs and expectancies for success decline across the elementary school years and into the middle school years (Jacobs, Lanza, Osgood, Eccles, & Wigfield, 2002)). Along with competence-related beliefs, research has found that students' valuing of certain academic domains declines as they grow up. For example, children's beliefs about the usefulness and importance of math, reading, instrumental music, and sports were found to decrease. However, their interest was only found to decrease in math and instrumental music (Wigfield, et al., 1997).

Students' individual interest can develop but the development needs to be supported (Renninger & Hidi, 2002). Approximately two well-developed individual interests can be identified for most children at age three and four. By age ten to twelve, approximately six well-developed individual interests can be identified. The contents of these individual interests tend to be stable and can be hold across high school years. However, some shifts from one academic domain to another do occur during this process, especially during middle school years (Renninger & Hidi, 2002).

With regard to students' innate needs, beginning in the middle school, students' feeling of competence declines due to the intensifying social comparisons and the advent

of competitive grading system (Convington & Dray, 2002). However, their need for competence to prove themselves via an ability status increases as they move from elementary school into middle school (Convington & Dray, 2002). Comparing to their elementary years, 6th graders start to display a stronger need for developing peer relationships and a sense of belongingness (Wentzel, 1999). Inconsistent research findings regarding students' perceived autonomy have been revealed by different findings. For example, Eccles, et al., (1993) found that middle school environment provides few opportunities for students to be involved in making decision, whereas Convington & Dray (2002) reported that students perceive increased opportunities for autonomous decision making in the transition to middle school years.

Overall, students' motivation declines when they get older. Particularly, students' academic competence beliefs, interest, and intrinsic motivation decline overtime. Wigfield and colleagues argued that these declines result from changes in individual students as well as changes in school contexts (Wigfield, Eccle, & Rodrigues, 1998). However, in terms of achievement goal orientations, Schunk & Pajares (2002) revealed that the changes in individuals' achievement goal orientations are the function of changing learning environments, rather than enduring personality traits of individual learners. Nevertheless, what is becoming increasingly clear is the powerful effect of context on student motivation.

When students progress through elementary school, middle school, and move into high school, the nature of the contexts they experience changes throughout development (Anderman, Austin, & Johnson, 2002). Wigfield et al. (1998) indicated that many of the changes in students' motivation occur when they move from elementary to middle school.

Eccles & Midgley (1989) explained that there is a shift in the focus of classroom as students move from elementary schools into middle schools. More specifically, students often perceive middle schools as focusing more on ability, performance, and grades, whereas they perceive elementary schools as focusing more on mastery and intrinsic motivation (Eccles & Midgley, 1989; Schunk & Pajares, 2002). These changes during this transition period have been documented in motivation research. First, peer networking are broken when students move into a middle school and are exposed to many different peers whom they do not know (Schunk & Pajares, 2002; Wigfield et al., 1998). During this transition period, Wigfield et al. (1991) found that students' sense of social competence dropped to the lowest level. Second, the organization of instruction changes in middle school. Such changes may increase social comparison, concerns about evaluation, and competitiveness, which require students reassess their academic capabilities (Schunk & Pajares, 2002; Wigfield et al., 1998). In summary, many aspects of middle school have effects on the development of students' motivation when they move from elementary into middle school, which indicates that early middle school year is a critical time for students to adopt new strategies to maintain motivation in learning. Given the apparent contextual and personal changes, new middle school students, presumably, are search for new strategies to motivation themselves to learn. With strong external control in the middle school environment, adaptive to extrinsic motivation may be an appealing option for them. SDT provides a particularly useful lens for the researchers to examine students' motivation at this critical age. Such investigation will help us understand students' motivation development in relation to their adoption of different behavioral regulation strategies that may lead to learning achievement. Further,

how SDT model is manifested in 6th grade physical education is not clear. Therefore, understanding how students' need satisfaction and their self-regulated motivation may provide insightful information for developing appropriate motivational strategies to help student learning and achievement in their middle school transition. It may also provide recommendations for educators to focus on facilitating the true developmental needs of early adolescents.

Curriculum Ramifications of SDT Research

Based on the social constructivism, learning relies heavily on social interactions and cultural influences. Yet, knowledge cannot exist without individuals' construction. The central goal of social interactions is to nurture and enhance learning, as described in Figure 2.1. The process of learning then is a process of internalization (Vygotsky, 1978) where the student actively internalizes the external social and cultural values into his/her own as knowledge is constructed and stored. In the social constructivist learning environment, students are expected to adopt behavior regulations that help develop strong motivation for learning through interaction with the content, peers, teachers, and their prior knowledge and experiences. The curriculum is assumed to be a means that can help the process. However, this function of the curriculum has received little empirical attention. The literature reviewed seems to provide a strong basis for a study using a joint theoretical perspective of SDT and social constructivism of learning because both theoretical perspectives share a common belief that students' self determination is the driving force of meaningful learning.

Social constructivists believe that a learning environment with positive social interaction can facilitate students' knowledge construction. Similarly, the self-

determination theory holds that internalization is the process in which students interact with peers, teachers, and the content to develop self-determined motivation for learning. SDT (Deci & Ryan, 1985; Ryan & Deci, 2000a) views internalization as an active process through which individuals transform external attitudes, beliefs, or behavioral regulation into their own values, beliefs, or regulations. Therefore, a curriculum incorporates both social constructivist learning theory and self-determination theory may help students' cognitive and motivational development and optimal learning.

In physical education, Azzarito and Ennis (2003) described a social constructivist pedagogical approach which helped students connect to each other, their teachers, their prior knowledge or experience, and new knowledge. They examined this approach in two middle class, public school physical education classrooms. Their results suggested that in these classes, social constructivist pedagogical approach enhanced a “sense of connection among students, students and teachers, and students’ and teachers’ communities” (p.195). In another study, Sun et al. (2006) examined the effects of a constructivist physical education curriculum on elementary school students’ learning. Participants in the experimental group (15 randomized elementary schools) received a new curriculum that was designed using the social-constructivist approaches. Students in the control group schools (n=15 schools) were taught with a traditional curriculum. The results suggested that students in the social constructivist experimental curriculum condition performed significantly better on the cognitive knowledge tests than did the students in the control schools. A regression analysis showed that that the experimental curriculum contributed 38.9% of the variance to students’ knowledge gain (Sun et al, 2006).

It is assumed that students will become intrinsically motivated to learn in a social constructivist curriculum (Oldfather, West, White, & Wilmarth, 1999). From a social constructivist learning perspective, motivation should be “linked explicitly to ways of knowing, understanding, and constructing meaning” (Oldfather & Dahl, 1994, p.139). To do so, researchers need to explore how motivation is generated in a social constructivist curriculum environment. Therefore, it is critical to examine the model of SDT with students’ learning in physical education. Such investigation may help us find the possible connection between social constructivist learning and self-determination of motivation in curriculum development and offer strategies that teachers can use to enhance student learning in physical education.

APPENDIX C

METHODOLOGY

The general purpose of this study is to examine the interrelations among students' three innate needs, motivational patterns, and learning in middle school physical education using the self-regulated motivation model as related to students' learning. To achieve the research purposes, the study is focused on answering the following specific research questions: (a) To what extent does students' satisfaction of the innate needs for autonomy, competence, and relatedness contribute to their intrinsic motivation and the self-regulation processes? (b) How critically does each self-regulation process function to contribute to or impede cognitive knowledge growth and motor skill improvement? and (c) Whether and to what extent do the External Regulation and Amotivation have a detrimental impact on knowledge growth and motor skill improvement in physical education? Specific research hypotheses are (a) Students' satisfaction of the innate needs for autonomy, competence, and relatedness will contribute to students' intrinsic motivation, identified regulation, and introjected regulation and negatively predict their external regulation and amotivation, (b) Students' intrinsic motivation and identified regulation will contribute to cognitive knowledge growth and motor skill learning while, (c) students' introjected regulation may not contribute to knowledge and motor skill learning, and (d) external regulation and amotivation may have detrimental impact on knowledge and motor skill learning.

I will use a correlational research design in accordance with the structural equation modeling approach. Given the fact that SDT is a mature theory and its constructs have been determined to be relatively stable in learning environments, the established a priori

model (see Figure 1.3) can be used in the structural equation modeling process to examine the research hypotheses. In the following section, I will discuss the details of research methodology that consists of (a) sample size determination, (b) the research settings and participants, (c) the physical education curriculum context in which the research will be conducted, (d) variables and measures, (e) data collection protocol and procedures and, (f) data analysis.

Sample Size Determination: *A Priori* Power Analysis

Adequate statistical power is needed in SEM designs to determine the probability and the sample size needed to test the statistical hypothesis that the theoretical (a priori) model is not supported by the data. Therefore, the null hypothesis for the data-model fit test is: $H_0: \epsilon \geq \epsilon_0$, and the alternative hypothesis can be defined as $H_1: \epsilon < \epsilon_0$ (Hancock, 2006). For SEM, it is advantageous to conduct an a priori power analysis rather than using the post hoc method to determine the sample size needed to test the hypothesis (Hancock, 2006).

In SEM, the root mean square error of approximation (RMSEA), ϵ , is a population-based index of fit (Steiger & Lind, 1980). It has an explicit parsimony adjustment and is relatively insensitive to sample size (Loehlin, 2004). A value of RMSEA of equal or less than .05 indicates a close fit of the whole model in relation to the degree of freedom (Loehlin, 2004). In the model-data-fit analysis, $\epsilon_0 = .05$ is defined as the threshold to determine acceptable and unacceptable data-model fit. When the computed ϵ is greater than ϵ_0 (.05), the statistical null hypothesis mentioned above is accepted, meaning that the data do not support the model. Conversely, when the computed ϵ is smaller than ϵ_0 (.05), the aforementioned null statistical hypothesis is rejected, indicating a good fit between

the data and the model. Thus, it is the interest of the power analysis to determine a sample size that will provide enough statistical power to rightfully reject the null hypothesis (when it is not true).

Hancock and Freeman (2001) created power tables in which ϵ_0 is set to the recommended value of .05, where $\epsilon = .00, .02, \text{ and } .04$. For each level of ϵ , sample size is determined by the chosen level of power and the degrees of freedom of the model. It is generally acknowledged that the minimum level of power (π) of 80% (.80) is needed for appropriate confidence. Hancock (2006) recommended that $\epsilon = .02$ is a reasonable level when researchers want to achieve sufficient power to reject the H_0 , whereas $\epsilon = .00$ seems to be unrealistically optimistic and $\epsilon = .04$ seems to be impractically conservative.

To determine the sample size needed for testing the model, it is necessary to compute the degree of freedom of the hypothesized model. The degree of freedom is determined using the formula $df = u - t$, where u stands for the number of unique variances and covariances explained by the observed variables (i.e., measurement items students will respond to in this study) and t (unknowns) represents the number of parameters to be estimated. The number (u) of unique variances and covariances of observed variables can be obtained by using the equation of $p*(p+1)/2$, where p is the number of observed variables. As shown in Appendix A, there are 37 items to which response scores will be collected and used to test the model. Thus, u equals $37*(37+1)/2 = 703$. The t is the number of unknown parameters in the model that need to be computed in the process of analysis. These parameters include path coefficients, first-order and second-order factor loadings, estimated variances and covariances, and error terms. As can be seen in Figure 1.3, there are 23 path coefficients, 12 first order factor loadings, 15 second order factor

loadings, 43 variances and covariances (including 37 error terms), and 5 disturbance terms, bringing a total of 98 unknown parameters (t). Thus, the degree of freedom in the hypothesized model is $703-98 = 605$.

To determine the sample size necessary to test the data-model fit as a whole of the hypothesized model, the tables in Hancock (2006) were used with $\alpha = .05$, $\pi = .80$, $\varepsilon = .02$, and $df = 605$. The tables suggested that a random sample size of 125 was needed to detect significant data-model fit for the hypothesized model for the present study. When $\varepsilon = .00$ and $\varepsilon = .04$ are used in the Hancock's (2006) table, the sample sizes needed are 101, 403, respectively.

In order to determine the sample size needed for the present study carefully and conservatively, I conducted another power analysis using the technique suggested by MacCallum, Browne, and Sugawara (1996). This approach also uses the RMSEA index as the metric for sample size determination. In this approach, with $\alpha = .05$, $\pi = .80$, $\varepsilon_0 = .05$, and $df = 605$, the desired sample size to test of close fit ($\varepsilon = .08$) is approximately 50. To test the exact fit ($\varepsilon = .05$) with $\alpha = .05$, $\pi = .80$, $\varepsilon_0 = .00$, and $df = 605$, the minimum sample size is approximately 60. To test the not close to fit ($\varepsilon = .01$) with $\alpha = .05$, $\pi = .80$, $\varepsilon_0 = .00$, and $df = 605$, the minimum sample size is approximately 90.

Based on the above sample sizes determination analyses, it is clear that the minimum sample size needed for this particular study ranges from 50 (extremely liberal) to 403 (unrealistically conservative). Therefore, it is reasonable to argue that a sample size between 200 to 300 will be appropriate for the examination of the model-data fit hypothesis.

Nature of the Study, the Setting, and Participants

Nature of the Study

The dissertation study will be conducted as a part in a larger investigation on middle school students' motivation, learning, and lifestyle change. The larger study is a 3-year project involving 15 elementary and 15 middle schools in a large school district. In this project, the school district is field-testing a new K-8 curriculum that emphasizes the learning of skillfulness, health-related fitness concepts, and personal and social responsibility for active living. This dissertation study will be conducted in middle schools only. This dissertation is also designed before the newly developed curriculum is actually implemented in middle schools. Although it is a part of the larger project, the dissertation study is relatively independent from the original project for the following reasons. First, the dissertation study will use a different theoretical framework to study learner motivation, learning, and their relationships. The over-arching theoretical framework in the original study is one integrating the interest-based motivation theory and the expectancy-value theory. Second, the dissertation study is focused on the relationship of learner motivation and learning outcome in the within-school learning environment, while the larger study is focused on learner motivation and learning in schools and their impact on children's and adolescents' in-school and after-school physical activity behavior change. Third, the dissertation study will collect data on learner satisfaction of the innate needs and self-regulated motivation approaches, variables not included in the original, larger study. Fourth, the dissertation study is descriptive in nature using a correlation design, while the larger study is a longitudinal, intervention investigating on changes over time. Thus, the dissertation study is relatively independent in its research purpose, scope, and approach.

The Setting

The school district is the 17th largest school district in the United States. It serves 137,798 students, 59% of whom are minorities, including 22.9% African Americans, 0.3% American Indians, 14.8% Asian Americans, 41.3% European Americans, and 20.7% Hispanic/Latino Americans; and 39% receive meal assistance (National Center for Education Statistics [NCES], 2006). This school district serves a diverse population and is uniquely positioned to provide generalizable research results to urban and suburban school districts serving students from diverse ethnic, socio-economic, and urban/suburban backgrounds. In April 2006, the County Board of Education passed the Policy for Wellness – Physical and Nutritional Health that calls for strengthening nutrition education and physical education programs to educate students to develop healthful, active life styles. Since 2005, prior to the issue of the policy, the district had begun to design an innovative physical education curriculum to achieve the physical education goals.

The school district bases its overall educational policy on a holistic belief that children develop better when they receive a balanced K-12 education. In recent years, educators in this school district have been working diligently and consistently to address concerns about adolescent obesity and physical inactivity. For example, of the 530 certified physical education teachers in the district, 225 (42%) are currently assigned to teach in middle schools. Students are required to take physical education in three of the four academic quarters each year, with the remaining quarter dedicated to health education. All middle schools are equipped with at least one large gymnasium and adequate outside field space for current curriculum offerings.

Participants

Participants for this study will be middle school students in sixth grade who are participating in the larger study. In the larger study, participants are sixth, seventh, and eighth grade students ($N=1350$) from 15 middle schools randomly selected from 38 middle schools in sixth grade, in particular, includes 380 students. There are 181 girls (47.7%) and 199 boys (52.3%). They are from multi-ethnic cultural backgrounds and from low, middle, and affluent socio-economic families, according to a 2005/2006 school report. The students represent different racial groups, 22 % African American, 44.8% Caucasian American, 18.2% Hispanic American, 18.2% Asian American, and 0.3% Native American. All participants in the larger study have had their parent permission as required IRB and assented for participation. In addition, students are told that they may choose to withdraw whenever they decide.

The primary reason to use sixth grade students in the current study is that at this stage they are experiencing a physical education curriculum different from what they had in elementary school. Therefore, the knowledge and skill growth measured in the study can be largely attributed to their learning during the learning experiences during the year. In other words, the internal validity for the measure of learning outcome can be preserved. This is critical for this study because learning is added into the model.

Physical Education Curriculum

MCPS offers physical education in 180 minutes per week to middle school students. The middle school physical education curriculum focuses on educating students to become skillful, fit, and personally and socially responsible movers. The curriculum is the typical multi-activity physical education. In this curriculum, students are exposed to a

variety of sport activities. In the larger project, the instruction of the curriculum has been monitored in the 15 participating middle schools through the measures of important instructional variables using a systematic observation instrument and physical activity recording devices, accelerometers. The data from the measures include student time spent on listening to instruction, cognitive tasks, skill development tasks, fitness development tasks, and being managed in class; and their physical activity engagement intensity (average MET/minute). The data, originally designed to measure the fidelity of curriculum implementation, can be used in the dissertation study as control variables for time spent on cognitive and skill development tasks. Both are covariates for the knowledge and skill growth measures used in this study.

Variables and Measures

In order to answer the research questions, the following variables are to be measured: (a) learner need satisfaction, (b) types of self-regulations, (c) cognitive knowledge growth, (d) motor skill change. Consistent with research in education and physical education, students' need satisfaction will be measured on their perceptions of autonomy, competence, and relatedness in class. Types of self-regulation in motivation will include amotivation, external regulation, introjected regulation, identified regulation, and intrinsic motivation. Students' knowledge growth will be measured in the domain of health-related fitness development and exercise principles, a central area of instruction in the curriculum. Motor skills will be assessed in striking skill (using badminton clear stroke motion) and coordinated footwork (basketball control dribble); both can be considered as fundamental skills necessary for participating life-long physical activity – the skill development goal of the curriculum.

Need Satisfaction

To measure students' perceived satisfaction of the three innate needs, I will use three previously validated instruments that are included in Appendix B. Scores obtained from each instrument will be used to represent the latent variables of perceived autonomy, competence, and relatedness.

Autonomy. Perceived autonomy will be assessed using five items by Standage et al. (2003a, 2005). Sample items include "I have some choice in what I want to do" and "I feel that I do PE because I want to" with a stem "In the physical education class" Students respond to a 7-point Likert scale ranging from 1 (*strongly disagree*) and 7 (*strongly agree*). Previous research has reported that this measure has Cronbach's alphas above .80 ($\alpha = .81$ in Standage et al., 2003; $\alpha = .80$ in Standage et al., 2005).

Competence. Participants' sense of competence will be measured using five items by Standage et al. (2003a; 2005) that were derived from the 18-item Intrinsic Motivation Inventory originally developed by McAuley, Duncan, and Tammen (1989). An example item from this instrument is "I am pretty skilled at PE." Responses are indicated on the same 7-point Likert scale. The internal reliability of this reworded five-item measure has been reported in previous studies ($\alpha = .85$ in Standage et al., 2003a; 2005).

Relatedness. Received relatedness will be measured using the five items that Standage et al. (2003a, 2005) adapted from the Need for Relatedness Scale by Richer and Vallerand (1998). Following the stem of "With the other students in my PE class, I feel" are five descriptors of "supported", "understood", "valued", "safe", and "listened to" with the same 7-point Likert scale. The internal reliability coefficients have been satisfactory ($\alpha = .91$ and $.87$ in Standage et al., 2003a, 2005; respectively).

Self-Regulated Motivation

SDT differentiates types of behavioral regulation in terms of the degree to which they regulate one's determination. Intrinsic motivation is the most self-determined regulation (Ryan & Deci, 2000c). The four behavioral regulations in the extrinsic motivation dimension (Figure 1.1) include external regulation, introjected regulation, identified regulation, and integrated regulation, in the order from the least internalized (externally regulated) to the most fully internalized motivation (integrated regulation). Amotivation, is a state of no intention or motivation for a particular activity.

To measure different types of motivation, Ryan and Connell (1989) developed and validated the Questionnaire of Self-Regulation in elementary and middle school students. They surveyed a small number of elementary schools teachers and conducted one-on-one interviews with children to categorize different motivational sources. On the basis of these surveys and interviews as well as the fundamental facets of SDT, Ryan & Connell (1989) developed the self-regulation instrument. In their study (Ryan & Connell, 1989), internal consistency estimates (Cronbach α , Cronbach, 1951) from various samples were .65, .62, .62, and .62 for the external category; .77, .79, .82, and .69 for the introjected category; and .85, .85, .86, and .67 for the identified category. Integrated regulation is not included in the questionnaire because Ryan and Connell (1989) suggested that elementary and middle schools students are too young to have achieved a sense of integration with respect to school academic activities.

To adapt the questionnaire into physical education setting, Gouda and Biddle (1994) modified and validated the original Self-Regulation Questionnaire (SRQ) by Ryan and Connell (1989). In various validations involving factor-analytical procedures for

construct validity, the modified SRQ has shown distinct factor structures and good internal reliability (Cronbach $\alpha > .80$); except that introjected regulation subscale has shown a little weaker internal consistency ($.60 < \alpha < .70$) in some subsequent studies (e.g., Ntoumanis, 2001, 2005). The adapted questionnaire includes five four-item subscales that measure intrinsic motivation, identified regulation, introjected regulation, external regulation, and amotivation. The items are attached to a 7-point Likert type scales with the Strongly Disagree pole as 1 and the Strongly Agree pole as 7. Each item begins with a common stem “I take part in PE...” followed by the statement for rating such as “because PE is exciting” (intrinsic motivation), “because I want to learn sport skills” (identified regulation), “because I would feel bad about myself if I did not” (introjected regulation), “because I will get into trouble if I don’t ” (external regulation), and “but I really feel I am wasting my time in PE” (amotivation).

Learning Outcomes

In the present study, learning outcomes in physical education are operationally defined as the degree to which students’ knowledge and psychomotor skill have grown or improved after instruction. The cognitive knowledge is defined in the domain of health-related fitness concepts and principles of engaging in health-enhancing physical activities. The arm striking skill, object-manipulation skill, and footwork movement skill are considered in the school district curriculum to be the foundation for the life-long participation in a variety of physical activities. Assessing student learning in these two areas is consistent with the curriculum goal for students to develop knowledge and physical skills for life-long physically active living.

Cognitive knowledge test. Students' knowledge about physical activity and its benefits will be assessed using a standardized knowledge test developed and validated for the larger study. The majority of the questions are adapted from validated, standardized question bank developed by Zhu, Safrit, and Cohen (1999). The test questions are differentiated and validated for each grade from 3rd to 8th and tap into concepts associated with the five major health-related fitness and principles to develop them. For each grade 24 questions are split into two equivalent tests. The following are two sample questions.

Question 1: Ability of the heart, lungs, and blood vessels to function efficiently when a person exercises the body is .

- (a) Muscular endurance (b) Target heart rate (c) Cardiorespiratory fitness

Question 2: Teens who are at least moderately active and in good health are advised to work at .

- (a) Between 60 and 90 percent of their target heart rate range
(b) 45 percent of their target heart rate range
(c) Between 60 and 90 percent of their estimated VO₂ max
(d) 45 percent of their estimated VO₂ max

As can be seen in the example, the questions are in multiple-choice format. A correct answer will be assigned a score of 1; incorrect choices will be assigned a score of zero (0). The maximum possible score a student may earn is 12. The total score earned represents the performance on the test and, consequently, represents how much a student knows about the content.

Motor skill tests. The movement to be used to assess arm striking skill will be the badminton striking skill. Arm striking is a fundamental movement that can be performed in different planes and is required in performing many physical movement forms involving the upper body (Gallahue, 1996). A test designed by Lockhart and McPherson (1949) has been used in the larger study due to its nature of a standardized test and accompanying validated norm for scoring. The purpose of this test is to measure students' badminton clear striking skill. The striking pattern in the test may also be transferred to learning and playing tennis, racquetball, handball, and volleyball. Therefore, it has a broad implication for future effective participation in physical activity. The test-retest reliability coefficient of this test has been reported to be .90 and validity coefficient has been reported to range from .71 to .90 by using criterion measures of judges' ratings and round robin tournament (Lockhart & McPherson, 1949).

When taking the test (Figure 3.1), the student assumes a service stance in back of the starting line on the floor 6 ½ feet from and parallel to the base of the wall. On the signal "Ready, go!" the examinee serves the shuttle against the wall. The shuttle is then hit as many times as possible during a 30-second time period, as long as it is hit from behind the restraining line, which is 3 feet from and parallel to the base of the wall, and above a 5-foot line on the wall. Three 30-second trials are taken. A 15-second practice session is permitted before testing. A point is scored each time the shuttle is hit during each trial and the total test score is the sum of the legal hits in three trials. The total score is the sum of the legal hits in each trial.

Figure 3.1 Lockhart-McPherson Badminton Test Setup.

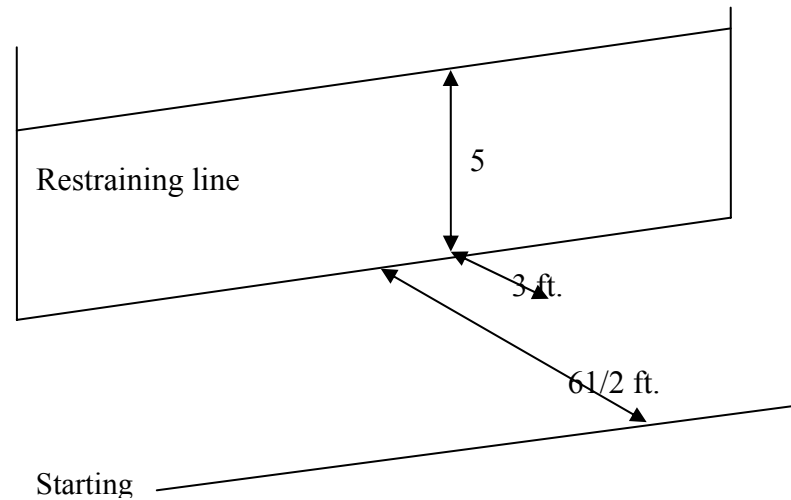

The second psychomotor skill test is the basketball control dribble test validated by American Alliance for Health, Physical Education, Recreation & Dance (AAHPRED, 1984). This test was designed to assess students' skill in handling and controlling the basketball while the body is moving. This test is important in that it emphasizes coordinated whole body movement, footwork, and object manipulation; all are fundamental skills for effective participation in health-enhancing physical activities. The validity of the test has been reported to range from .37 to .91 for both genders and the reliability has been showed to range from .93 to .97 for females and from .88 to .95 for males.

The test is administered on half a regulation-size basketball court. Six cones are placed inside the lane as described in Figure 3.2. The student starts dribbling the basketball from the first cone (cone A) and pass other five cones in a fixed sequence as fast as he/she can (Figure 3.2). The left diagram in the Figure 3.2 can be used for right-handed students and the right one for left-handers. On the signal "Ready, go!" students

use the non-dominant hand to dribble the ball from cone A to the non-dominant side of cone B. Students can use either hand to dribble the ball. The time from the start to finish is recorded by a tester with a stopwatch. The trial score is the time required to complete the course legally. The total test score is the sum of the times for two trials.

Figure 3.2 Court markings for the AAHPERD Basketball Control Dribble Test (From AAHPERD, 1984)

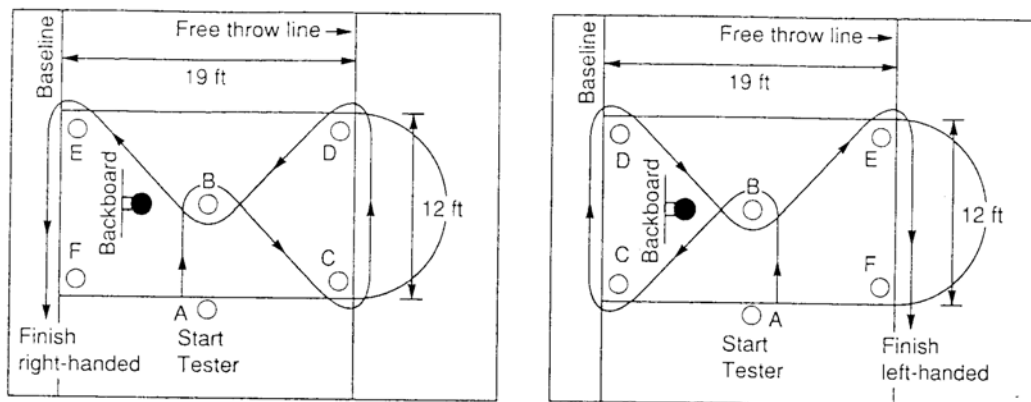

Research Design and Procedures

Although the study is correlational in nature, the variables of learning knowledge and skill are defined as growth of knowledge and improvement of physical skills. Therefore, students' knowledge and physical skills must be measured in a pre-test and post-test design to allow growth and improvements to be calculated. The pre-tests were conducted in the fall semester of 2006 for the larger study. Post-test data on knowledge and skill assessments will be collected in the spring semester of 2007. Knowledge growth and skill improvement scores will be obtained by regressing the post-test scores on pre-test scores to control for ceiling effects and any statistically significant discrepancies among groups of students on pretest scores. Students' innate needs and self-regulation

data will be gathered prior to the post-tests of knowledge and skills. Table 3.1 below is the time line for the data collection.

Table 3.1 Data Collection Time Line

Variables	Collecting time
Pre-knowledge test	Fall 2006
Pre-motor skill test	Fall 2006
Need satisfaction	April, 2007
Self-regulated motivation	April, 2007
Post-knowledge test	April & May, 2007
Post-motor skill test	April & May, 2007

Data Collection Procedure

Although the instruments and tests used in the study have been previously validated, the following threats to the internal reliability of measures are likely to exist due to the nature of a field-based study. The threats include (a) discrepancy of implementing data collection protocols that leads to low inter-observer agreement; (b) students' incorrect responding to the measurement instruments due to discrepant instructions and mechanical errors associated with the production of the instrument (printing), which leads to inproportionally large amount of un-scannable responses; (c) students' providing "socially desirable" responses to the self-report instruments; and (d) inequitable facility and equipment in schools that prevent teachers from following the correct testing protocols for the skill tests.

To minimize the threat to reliability with respect to the discrepancies among teachers and data collectors, both physical education teachers and data collectors have been trained with the testing protocols we established. Physical education teachers are provided with detailed instructions for data collection and the opportunities to discuss the data collection protocols in a series of workshops hosted by the county physical education supervisor. Instructional and reminding emails are sent to teachers regularly by the project PI and the dissertation researcher. The data collection is ongoing. Data collectors and I report to the PI with updated information weekly. Any concerns about data quality have been addressed immediately.

Undergraduate data collectors have received a three-day training before they enter the schools. In the training sessions, they are given an overview of the larger project and data collection protocols and learn the policies and regulations of public schools. They also practiced data collection procedures and conducted inter-observer agreement reliability checks. In addition, teachers and data collectors receive a detailed timeline for administering tests and surveys to secure the consistency of the protocol across sites.

Knowledge tests and SDT surveys are designed in Scantron forms so that data can be entered into computer by a special scanner. To ensure the responses on the designed forms can be scanned accurately into database, it is the standardized operational procedure that I print out small samples of each form (tests and questionnaires) and two or three project team members use number 2 pencils to complete the tests and surveys as instructed. The responses are randomly selected to detect if the scanner can scan these responses correctly. Before we officially bring the tests and surveys to schools, a 100% accuracy of scanning response must be achieved for each form. Step-by-step instructions

for administering each instrument are attached on each envelope so that the teachers and data collectors can review them before administering the instrument.

The pre-test knowledge and skill data were collected in the fall semester of 2006 and post-test data will be collected in the spring semester of 2007. The data on students' innate needs and types of self-regulation will be collected before the collection of the post-test knowledge and skill data. Innate needs and self-regulations surveys will be administered simultaneously in spring 2007. Data collector and I will administer these surveys during their regular physical education classes in the gymnasium. We will read the items on surveys to students and answer questions that students may have. To secure the independence of students' responses during the data collection, students are told to work on the test and surveys individually and encouraged to respond to the items on the test and surveys as truthfully as they can. All students are informed that their teachers will not have the access to their individual responses and will not use their responses for the grading purpose. Knowledge tests will be administered by the physical education teachers in their regular physical education classes in gymnasium after we collect the SDT data. The protocol of knowledge test will be the same as SDT surveys.

Physical education teachers will administer post- knowledge tests immediately after they have completed the instruction of the curriculum for the sixth grade. Trained data collectors and I will assist teachers with administering the knowledge tests. Skills tests will be individually administered by physical education teachers to individual students to maintain measurement independence. Teachers follow the instructions of the skill tests I discussed in the previous section. Data collectors and I may assist teachers with the skill tests based upon their request, but teachers should take the primary

responsibility. Skill data are stored on spreadsheet by using MS Excel and any paper-based data records are entered into computer database by hand.

At the beginning of fall 2006 semester, physical education teachers sent out parents' permission forms and data collection started after teachers received parents' permission. To secure the independence of responses during the data collection, the students are told to work on the test and surveys individually and encouraged to respond to the items on the test and surveys as truthfully as they can. All students are informed that their teachers will not have the access to their individual responses and will not use their responses for grading purpose.

Data Analysis

Three parts are included in this section. In first section data reduction, the purpose of this part is to categorize and organize data for the SEM analysis. For example, the skill test scores will be standardized into T-scores, then will be aggregated as one score to represent the skill level. Improvement score will be computed using the regression residual adjustment procedure to control for ceiling effect and prior inequality of skill performance levels. In the second section preliminary analysis, I sort irregular scores, check distributions and the statistical assumptions for SEM. Descriptive statistics will be examined for distribution normality, irregular (outlier) responses, and missing value impact on the data. This phase of analysis will provide an overall description of the quality of data and such information can be used in the further discussion of the results. In the third section, SEM analysis and this is the major part of the data analysis. Three statistical assumptions of SEM will be tested in the process of preliminary data analysis: (1) linearity, (2) collinearity, and (3) multivariate normal distribution. Structural Equation

Modeling assumes that relationships among the variables are linear. A Pearson correlation will be conducted among variables in the model in order to test for linearity. A statistically significant correlation suggests a linear relationship. SEM also requires non-collinearity. Collinearity occurs if an observed variable is a linear combination of another observed variable. Collinearity can lead to a covariance matrix that is non-positive definite, which is problematic in SEM because estimation of SEM requires that the covariance or correlation matrix analyzed must be positive definite. A Pearson correlation analysis among all indicator variables will be performed to test for collinearity and high correlations could indicate a collinearity problem. Finally, SEM assumes that data must be continuous and multivariate normal. Nonnormality can lead to several inaccurate conclusions regarding the model being tested. The multivariate normality information will be obtained from the output of the software (EQS) I will use to conduct the SEM analysis. In addition, I will use robust maximum likelihood in case multivariate normality is not assumed.

Data will be analyzed using the structural equation modeling method. SEM is a statistical procedure that allows the researcher to address theory-driven causal research questions for both latent variables and the measurement models (Hancock & Mueller, 2006). Using SEM, researchers can test an entire system of structural equations simultaneously to determine how well the data fit the model. Structural equation modeling also provides estimates of error variances in order to correct for measurement error. Other methods such as regression do not take measurement error into consideration, which can result in misleading conclusions. Given these important considerations, SEM was chosen as the most effective method for analyzing the data for this study.

The SEM analysis consists of two general steps. First, measurement model specification will be performed. At this step, an initial measurement model (a priori) where all factors are allowed to covary will be tested. A model re-specification may be conducted if the data do not fit the initial model. The model re-specification is based on (a) intermediate outcomes of SEM. These outcomes consists of sets of indices that suggest possible improvement of data-model fit based on relationship of the observed and latent variables; and (b) researcher subjective adjustment of the relationships based on further theoretical articulation corresponding to the intermediate outcomes of SEM. The re-specification may lead to refined relationship among the latent variables (underlying constructs), which (the relationship among the latent variables) forms a structural model that allows an examination of the interrelations among the latent variables.

The second step, then, is to examine the tenability of the structural model. At this step, an initial structural model will be tested by imposing a priori, theory-derived structural hypotheses on latent variables in the final measurement model. If the data do not fit the initial structural model, a model re-specification may be employed. For example, in the hypothesized model, I hypothesize that students' three need satisfactions will contribute to different types of motivation either positively or negatively. If the data do not meet the specifications proposed in the hypotheses (the a priori structural model), then the paths between relatedness and external regulations and amotivation may need be adjusted. Technically, during the model re-specification, one path will be released each time based on the theory and related literature to that specific path.

APPENDIX D

Hypothesized model for the study (measurement model).

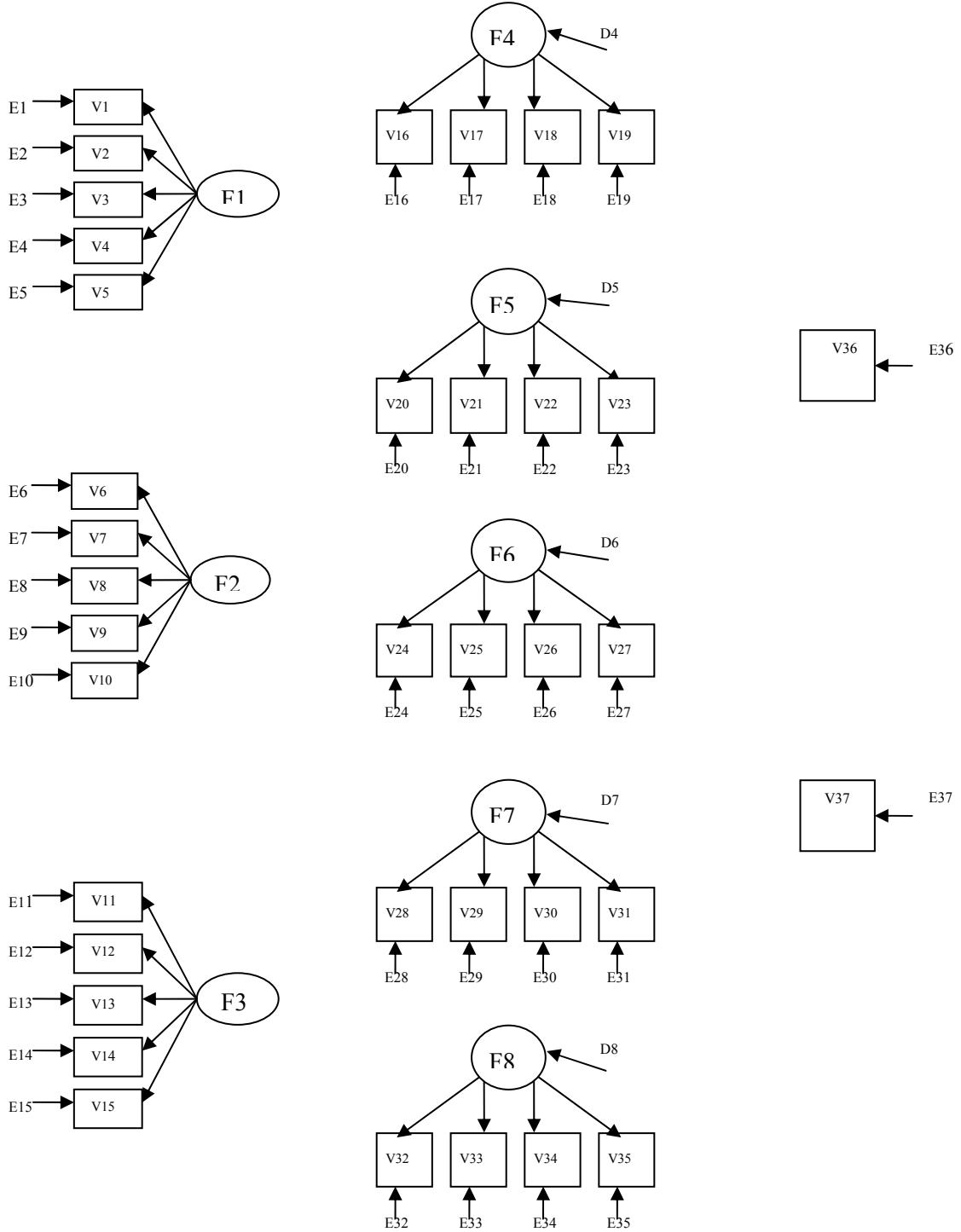

Hypothesized model of the study (Structural Model).

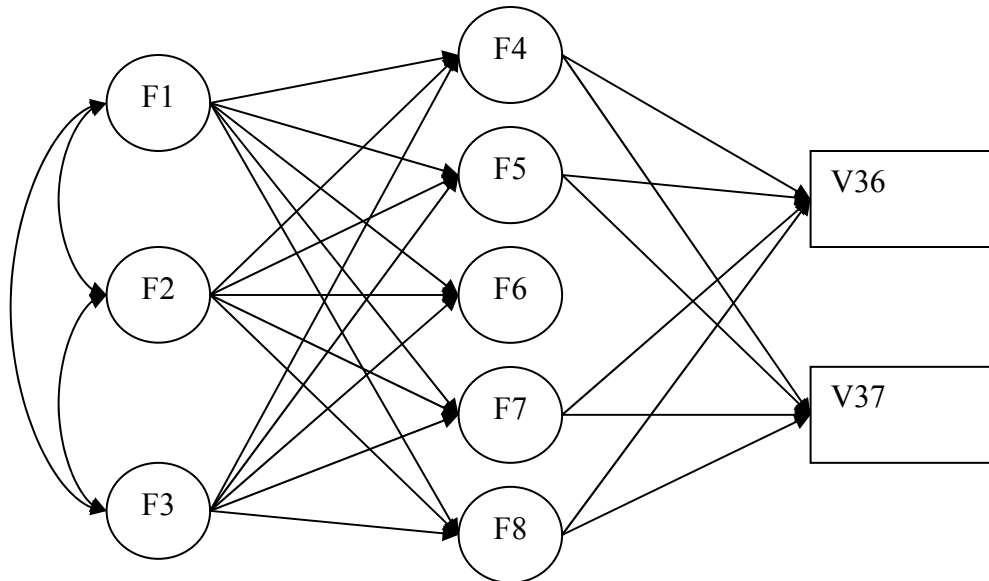

Note: F = latent variables; V = observed variables; E = measurement errors; D = disturbance; F1= need satisfaction of autonomy; F2= need satisfaction of competence, F3= need satisfaction of relatedness, F4= intrinsic motivation, F5= identified regulation, F6= introjected regulation, F7= external regulation, F8= amotivation; V36= cognitive knowledge; V38= motor skill.

APPENDIX E

6th Grade Knowledge Test Questions

#	Form #	Question
1		Physical activity done in short, fast bursts in which the heart cannot supply oxygen as fast as the muscles use it Aerobic activity Anaerobic activity Muscular endurance
2		Physical activity for which the body can supply adequate oxygen to allow performance to continue for long periods of time Aerobic activity Anaerobic activity Muscular strength
3		Ability of the heart, lungs, and blood vessels to function efficiently when a person exercises the body Muscular endurance Target heart rate Cardiorespiratory fitness
4		Lacking the necessary amount of body fluid Hydrated Sweating Dehydrated
5		The ability to move the joints through a full range of motion Aerobic fitness Core activities Flexibility
6		A muscle that when contracted bends a joint in the body Extensor Flexor Abdomina
7		The ability to contract the muscles many times without tiring or to hold one contraction for a long period of time Muscular strength Aerobic endurance Muscular endurance
8		The ability to use strength quickly Power Energy Fitness
9		The rule that states that in order to improve fitness, one needs to do more physical activity than one normally does Principle of Progression Principle of Specificity Principle of Overload
10		The rule that states that the amount and intensity of physical activity needs to be increased gradually Principle of Progression Principle of Specificity Principle of Overload
11		The rule that states that specific types of exercise improve specific parts of fitness or specific muscles Principle of Progression Principle of Specificity Principle of

		<p>A muscle or connective tissue is barely stretched</p> <p>A muscle or connective tissue is stretched just beyond its normal resting state</p> <p>A muscle or connective tissue is stretched well beyond its normal resting state</p> <p>None of the above</p>
23		<p>The top of the Physical Activity Pyramid consists of activities that you should</p> <p>Cut down on Do 2 or 3 times a week Do every day None of the above</p>
24		<p>The amount of force that a muscle can produce</p> <p>Muscular strength Aerobic endurance Muscular endurance</p>

APPENDIX F

Survey of Need Satisfaction and Self-regulation

Read the sentence carefully and think about yourself. Circle the number that shows how you feel. There are no right or wrong answers. Be as accurate and honest as you can about your feelings.

First Name: _____ Last Name: _____

In this PHYSICAL EDUCATION class:

I can decide which activities I want to practice.

strongly disagree	moderately disagree	slightly disagree	neutral	slightly agree	moderately agree	strongly agree
1	2	3	4	5	6	7

I have a say regarding what skills I want to practice.

strongly disagree	moderately disagree	slightly disagree	neutral	slightly agree	moderately agree	strongly agree
1	2	3	4	5	6	7

I feel that I do PHYSICAL EDUCATION because I want to.

strongly disagree	moderately disagree	slightly disagree	neutral	slightly agree	moderately agree	strongly agree
1	2	3	4	5	6	7

I feel a certain freedom of action.

strongly disagree	moderately disagree	slightly disagree	neutral	slightly agree	moderately agree	strongly agree
1	2	3	4	5	6	7

I have some choice in what I want to do.

strongly disagree	moderately disagree	slightly disagree	neutral	slightly agree	moderately agree	strongly agree
1	2	3	4	5	6	7

I think I am pretty good at PHYSICAL EDUCATION.

strongly disagree	moderately disagree	slightly disagree	neutral	slightly agree	moderately agree	strongly agree
1	2	3	4	5	6	7

I am satisfied with my performance at PHYSICAL EDUCATION.

strongly disagree	moderately disagree	slightly disagree	neutral	slightly agree	moderately agree	strongly agree
1	2	3	4	5	6	7

When I have participated in PHYSICAL EDUCATION for a while, I feel pretty competent.

strongly disagree	moderately disagree	slightly disagree	neutral	slightly agree	moderately agree	strongly agree
1	2	3	4	5	6	7

I am pretty skilled at PHYSICAL EDUCATION.

strongly disagree	moderately disagree	slightly disagree	neutral	slightly agree	moderately agree	strongly agree
1	2	3	4	5	6	7

I cannot do PHYSICAL EDUCATION very well.

strongly disagree	moderately disagree	slightly disagree	neutral	slightly agree	moderately agree	strongly agree
1	2	3	4	5	6	7

With the other students in this PHYSICAL EDUCATION class I feel:

Supported

strongly disagree	moderately disagree	slightly disagree	neutral	slightly agree	moderately agree	strongly agree
1	2	3	4	5	6	7

Understood

strongly disagree	moderately disagree	slightly disagree	neutral	slightly agree	moderately agree	strongly agree
1	2	3	4	5	6	7

Listened to

strongly disagree	moderately disagree	slightly disagree	neutral	slightly agree	moderately agree	strongly agree
1	2	3	4	5	6	7

Valued

strongly disagree	moderately disagree	slightly disagree	neutral	slightly agree	moderately agree	strongly agree
1	2	3	4	5	6	7

Safe

strongly disagree	moderately disagree	slightly disagree	neutral	slightly agree	moderately agree	strongly agree
1	2	3	4	5	6	7

I take part in this PHYSICAL EDUCATION class

because PHYSICAL EDUCATION is fun.

strongly disagree	moderately disagree	slightly disagree	neutral	slightly agree	moderately agree	strongly agree
1	2	3	4	5	6	7

because I enjoy learning new skills.

strongly disagree	moderately disagree	slightly disagree	neutral	slightly agree	moderately agree	strongly agree
1	2	3	4	5	6	7

because PHYSICAL EDUCATION is exciting.

strongly disagree	moderately disagree	slightly disagree	neutral	slightly agree	moderately agree	strongly agree
1	2	3	4	5	6	7

because of the enjoyment that I feel while learning new skills/techniques.

strongly disagree	moderately disagree	slightly disagree	neutral	slightly agree	moderately agree	strongly agree
1	2	3	4	5	6	7

because I want to learn sport skills.

strongly disagree	moderately disagree	slightly disagree	neutral	slightly agree	moderately agree	strongly agree
1	2	3	4	5	6	7

because it is important for me to do well in PHYSICAL EDUCATION.

strongly disagree	moderately disagree	slightly disagree	neutral	slightly agree	moderately agree	strongly agree
1	2	3	4	5	6	7

because I want to improve in sport.

strongly disagree	moderately disagree	slightly disagree	neutral	slightly agree	moderately agree	strongly agree
1	2	3	4	5	6	7

because I can learn skills which I could use in other areas of my life.

strongly disagree	moderately disagree	slightly disagree	neutral	slightly agree	moderately agree	strongly agree
1	2	3	4	5	6	7

because I want the teacher to think I'm a good student.

strongly disagree	moderately disagree	slightly disagree	neutral	slightly agree	moderately agree	strongly agree
1	2	3	4	5	6	7

because I would feel bad about myself if I didn't.

strongly disagree	moderately disagree	slightly disagree	neutral	slightly agree	moderately agree	strongly agree
1	2	3	4	5	6	7

because I want the other students to think I'm skilful.

strongly disagree	moderately disagree	slightly disagree	neutral	slightly agree	moderately agree	strongly agree
1	2	3	4	5	6	7

because it bothers me when I don't.

strongly disagree	moderately disagree	slightly disagree	neutral	slightly agree	moderately agree	strongly agree
1	2	3	4	5	6	7

because I'll get into trouble if I don't.

strongly disagree	moderately disagree	slightly disagree	neutral	slightly agree	moderately agree	strongly agree
1	2	3	4	5	6	7

because that's what I am supposed to do.

strongly disagree	moderately disagree	slightly disagree	neutral	slightly agree	moderately agree	strongly agree
1	2	3	4	5	6	7

so that the teacher won't yell at me.

strongly disagree	moderately disagree	slightly disagree	neutral	slightly agree	moderately agree	strongly agree
1	2	3	4	5	6	7

because that's the rule.

strongly disagree	moderately disagree	slightly disagree	neutral	slightly agree	moderately agree	strongly agree
1	2	3	4	5	6	7

but I don't really know why.

strongly disagree	moderately disagree	slightly disagree	neutral	slightly agree	moderately agree	strongly agree
1	2	3	4	5	6	7

but I don't see why we should have PHYSICAL EDUCATION.

strongly disagree	moderately disagree	slightly disagree	neutral	slightly agree	moderately agree	strongly agree
1	2	3	4	5	6	7

but I really feel I'm wasting my time in PHYSICAL EDUCATION.

strongly disagree	moderately disagree	slightly disagree	neutral	slightly agree	moderately agree	strongly agree
1	2	3	4	5	6	7

but I can't see what I'm getting out of PHYSICAL EDUCATION.

strongly disagree	moderately disagree	slightly disagree	neutral	slightly agree	moderately agree	strongly agree
1	2	3	4	5	6	7

Bibliography

- Ainley, M., Hidi, S., & Berndorff, D. (2002). Interest, learning, and the psychological processes that mediate their relationship. *Journal of Educational Psychology, 94*, 545-561.
- Alexander, P.A. (1998). Stages and phases of learning: The dynamics of domain knowledge, strategy knowledge, and motivation. In C.E. Weinstein & B.L. McCombs (Eds.) *Strategic Learning: Skill, Will, and Self-regulation*. Hillsdale, NJ: Erlbaum.
- Alexander, P.A. (2005). *Psychology in learning and instruction*. Columbus, OH: Prentice-Hall.
- Alexander, P.A., Jetto, T.J. & Kulikowich, J.M. (1995). Interrelationship of knowledge, interest, and recall: Assessing a model of domain learning. *Journal of Educational Psychology, 87*, 559-575.
- Alexander, P.A., Kulikowich, J.M. & Jetto, T.J. (1994). The role of subject-matter knowledge and interest in the processing of linear and nonlinear texts. *Review of Educational Research, 64*, 201-252.
- Alexander, P.A., Kulikowich, J.M. & Schulze, S.K. (1994). How subject-matter knowledge affect recall and interest. *American Educational Research Journal, 31*, 313-337.
- Ames, C. (1992). Classrooms: Goals, structures, and student motivation. *Journal of Educational Psychology, 84*, 261-271.
- Ames, C., & Ames, R. (1984). Goal structures and motivation. *Elementary School Journal, 85*, 39-52.

- Ames, C., & Archer, J. (1988). Achievement goals in the classroom: Students' learning strategies and motivation processes. *Journal of Educational Psychology, 80*, 260-267.
- Anderman, L. H., & Anderman, E. M. (1999). Social predictors of changes in students' achievement goal orientations. *Contemporary Educational Psychology, 25*, 21-37.
- Anderman, E.M., Austin, C.C., & Johnson, D.M. (2002). The development of goal orientation. In A. Wigfield & J.S. Eccles (Eds.), *Development of achievement motivation* (pp. 197-220). San Diego, CA: Academic Press.
- Azzarito, L., & Ennis, C.D. (2003). A sense of connection: Toward social constructivist physical education. *Sport, Education and Society, 8*, 179-198.
- Bandura, A. (1986). *Social foundations of thought and action: A social cognitive theory*. Englewood Cliffs, NJ: Prentice-Hall.
- Bandura, A. (1997) *Self-efficacy: The exercise of control*. New York: Freeman.
- Bentler, P.M. (2006). EQS 6 Structural Equations Program Manual. Encino, CA: Multivariate Software, Inc.
- Berlant, A.R., & Weiss, M.R. (1997). Goal orientation and the modeling process: An individual's focus on form and outcome. *Research Quarterly for Exercise and Sport, 68*, 317-330.
- Biddle, S.J.H., Cury, F., Goudas, M., Sarrazin, P., Famose, J.P., & Durand, M. (1995). Development of scales to measure perceived physical education class climate: A cross-national project. *British Journal of Educational Psychology, 65*, 341-358.
- Black, A.E., & Deci, E.L. (2000). The effects of instructor's autonomy support and

- students' autonomous motivation on learning organic chemistry: A self-determination theory perspective. *Science Education*, 84, 740-756.
- Cameron, J. & Pierce, D.W. (1994). Reinforcement, reward, and intrinsic motivation: A meta-analysis. *Review of Educational Research*, 64, 363-423.
- Carr, S. (2006). An examination of multiple goals in children's physical education: Motivational effects of goal profiles and the role of perceived climate in multiple goal development. *Journal of Sport Science*, 24, 281-297.
- Chandler, C.L., & Connell, J.P. (1987). Children's intrinsic, extrinsic and internalized motivation: A developmental study of behavioral regulation. *British Journal of Developmental Psychology*, 5, 357-365.
- Chen, A., & Darst, P.W. (2001). Situational interest in physical education: A function of learning task design. *Research Quarterly for Exercise and Sport*, 72, 150-164.
- Chen, A., Darst, P.W., & Pangrazi, R.P. (1999). What constitutes situational interest? Validating a construct in physical education. *Measurement in Physical Education and Exercise Science*, 3, 157-180.
- Chen, A., & Ennis, C.D. (2004). Goal, interest, and learning in physical education. *The Journal of Educational Research*, 97, 329-338.
- Chen, A., & Shen, B. (2004). A web of achieving in physical education: Goals, interest, outside-school activity and learning. *Learning and Individual Difference*, 14, 169-182.
- Connell, J.P. (1991). Context, self and action: A motivation analysis of self-system

- processes the life-span. In D. Cicchetti and M. Beeghly (Eds.), *The self in transition: Infancy to childhood* (pp. 61-97). Chicago: University of Chicago Press.
- Connell, J.P., & Wellborn, J.G. (1991). Competence, autonomy and relatedness: A motivational analysis of self-system processes. In M.R. Gunnar & L.A. Sroufe (Eds.), *Minnesota symposium on child psychology* (Vol. 22, pp. 43-77). Hillsdale, NJ: Erlbaum.
- Convington, M.V., & Dray, E. (2002). The developmental course of achievement motivation: A need-based approach. In A. Wigfield & J.S. Eccles (Eds.), *Development of achievement motivation* (pp. 33-53). San Diego, CA: Academic Press.
- Court markings for the AAHPERD Basketball Control Dribble Test (1984). AAHPERD *Skills test manual: Basketball for boys and girls*. Reston, VA: Author
- Corbin, C.B. (2002). Physical activity for everyone: What every physical educator should know about promoting lifelong physical activity. *Journal of Teaching in Physical Education, 21*, 128-144.
- Cothran, D.J., & Ennis, C.D. (1999). Alone in a crowd: Meeting students' needs for relevance and connection in urban high school physical education. *Journal of Teaching in Physical Education, 18*, 234-247.
- Cox, A.E., & Whaley, D.E. (2004). The influence of task value, expectancies for success, and identity on athletes' achievement behaviors. *Journal of Applied Sport Psychology, 16*, 103-117.
- Cronbach, L.J. (1951). Coefficient alpha and the internal structure of tests. *Psychometrika, 16*, 297-334.

16, 297-334.

- Deci, E.L. (1992). The relation of interest to the motivation of behavior: A self-determination theory perspective. In K.A. Renninger, S. Hidi, & A. Krapp (Eds.), *The role of interest in learning and development* (pp. 43-69). Hillsdale, NJ: Erlbaum.
- Deci, E.L., Eghrari, H., Patrick, B.C., & Leone, D.R. (1994). Facilitating internalization: The self-determination theory perspective. *Journal of Personality, 62*, 119-142.
- Deci, E.L., Koestner, R., & Ryan, R.M. (1999). A meta-analytic review of experiments examining the effects of extrinsic rewards on intrinsic motivation. *Psychology Bulletin, 125*, 627-668.
- Deci, E.L., & Ryan, R.M. (1985). *Intrinsic motivation and self-determination in human behavior*. New York: Plenum.
- Deci, E.L., & Ryan, R.M. (1991). A motivational approach to self: Integration in personality. In R. Dienstbier (Ed.), *Nebraska Symposium on Motivation: Vol. 38. Perspectives on motivation* (pp. 237-288). Lincoln: University of Nebraska Press.
- Deci, E.L., & Ryan, R.M. (2000). The “what” and “why” of goal pursuits: Human needs and the self-determination of behavior. *Psychological Inquiry, 11*, 227-268.
- Deci, E.L., Vallerand, R.J., Pelletier, L.G., & Ryan, R.M. (1991). Motivation in education: The self-determination perspective. *The Educational Psychologist, 26*, 352-346.
- Dempsey, J.M., Kimiecik, J.C., & Horn, T.S. (1993). Parental influence on children’s moderate to vigorous physical activity participation: An expectancy-value approach. *Pediatric Exercise Science, 5*, 151-167.
- Dewey, J. (1913). *Interest and effort in education*. Boston: Riverside Press.

- Digelidis, N., Papaioannou, A., Laparidis, K., & Christodoulidis, T. (2003). A one-year intervention in 7th grade physical education classes aiming to change motivational climate and attitudes toward exercise. *Psychology of Sport and Exercise, 4*, 195-210.
- Duda, J. L. (2001). Achievement goal research in sport: Pushing the boundaries and clarifying some misunderstandings. In G.C. Roberts (Ed.), *Advances in motivation in sport and exercise* (pp. 129-182). Champaign, IL: Human Kinetics.
- Dweck, C. S., & Leggett, E. (1988). A social-cognitive approach to motivation and personality. *Psychological Review, 95*, 256-273.
- Eccles, J., Adler, T.F., Futterman, R., Goff, S.B., Kaczala, C.M., MEECE, J.L., & Midgley, C. (1983). Expectancies, values and academic behaviors. In J.T. Spence (Ed.), *Achievement and achievement motivation* (pp. 75-146). San Francisco: W.H. Freeman.
- Eccles, J. S., & Midgley, C. (1989). Stagemenvironment fit: Developmentally appropriate classrooms for early adolescents. In R. Ames & C. Ames (Eds.), *Research on motivation in education* (Vol. 3, pp. 139-181). New York: Academic Press.
- Eccles, J., & Wigfield, A. (1995). In the mind of the actor: The structure of adolescents' achievement task value and expectancy-related beliefs. *Personality and Social Psychology Bulletin, 21*, 215-225.
- Eccles, J.S. & Wigfield, A. (2002). Motivational beliefs, values, and goals. *Annual Review of Psychology, 53*, 109-32.
- Eccles, J.S., Wigfield, A., Flanagan, C.A. (1989). Self-concepts, domain values, and self-

- esteem: Relations and changes at early adolescence. *Journal of Personality*, 57, *Special issue: Long-term stability and change in personality*, 283-310.
- Eccles, J., Wigfield, A., Schiefele, U. (1998). Motivation to succeed. In W. Damon (Series Ed.) & N. Eisenberg (Vol. Ed.), *Handbook of child psychology: Vol. 3. Social, emotional, and personality development* (5th ed., pp. 1017-1095). New York: Wiley.
- Elliot, A.J. (1997) Integrating the “classic” and “contemporary” approaches to achievement motivation: A hierarchical model of approach and avoidance achievement motivation. In M. Maehr & P. Pintrich (Eds.) *Advances in motivation and achievement* (Vol. 10, pp. 243-279). Greenwich, CT: JAI Press.
- Elliot, A.J. (1999). Approach and avoidance motivation and achievement goals. *Educational Psychologist*, 34, 169-189.
- Elliot, A.J. & Church, M (1997). A hierarchical model of approach and avoidance achievement motivation. *Journal of Personality and Social Psychology*, 72, 218-232.
- Elliot, A.J., & McGregor, H. (1999). Test anxiety and the hierarchical model of approach and avoidance motivation. *Journal of Personality and Social Psychology*, 76, 628-644.
- Ennis, C.D. (1999). Creating a culturally relevant curriculum for disengaged girls. *Sport, Education, and Society*, 4, 31-49.
- Ennis, C.D. (2000). Canaries in the coal mine: Responding to disengaged students using theme-based curricula. *Quest*, 52, 119-130.
- Ennis, C.D. (2003). Using curriculum to enhance student learning. In S.J. Silverman and

- C.D. Ennis (Ed.), *Student learning in physical education* (pp. 147-163).
Champaign, IL: Human Kinetics.
- Epstein, J.L. (1988). Effective schools or effective students: Dealing with diversity. In R. Haskins & D.J. MacRae, *Policies for America's public schools: Teachers, equity, and indicators* (pp. 89-126). Westport, CT: Ablex Publishing
- Feldman, S.S., & Wentzel, K.R. (1990). Relations among family interaction patterns, classroom self-restraint, and academic achievement in preadolescent boys. *Journal of Educational Psychology, 82*, 813-819.
- Ford, M. (1992). *Motivating humans: Goals, emotions, and personal agency beliefs*. Newbury Park, CA: Sage.
- Gallahue, D.L. (1996). *Developmental Physical Education for Today's Children* (3rd Eds.). Times Mirrior Higher Education Group, Inc.
- Goetz, E.T., & Sadoski, M. (1995). Commentary: The perils of seduction: Distracting details or incomprehensible abstractions? *Reading Research Quarterly, 30*, 500-511
- Goodlad, J.I. (1984). *A place called school: Prospects for the future*. New York: McGraw-Hill.
- Gouda, M., & Biddle, S. (1994). Perceived motivational climate and intrinsic motivation in school physical education classes. *European Journal of Psychology of Education, 9*, 241-250.
- Graves, M.F., Slater, W.H., Roen, D., Redd-Boyd, T., Duin, A.H., Furniss, D.W., &

- Hazeltine, P. (1988). Some characteristics of memorable expository writing: Effects of revisions by writers with different backgrounds. *Research of Teaching English, 22*, 242-265.
- Grolnick, W., Gurland, S., Jacob, J., & Decourcey, W. (2002). The development of self-determination in middle childhood and adolescence. In A. Wigfield & J. Eccles (Eds.), *Development of achievement motivation* (pp. 148-171). San Diego, CA: Academic Press.
- Guan, J., Xiang, P., & McBride, R. (2006). Achievement goals, social goals, and students' Reported Persistence and Effort in high school physical education. *Journal of Teaching in Physical Education, 23*, 58-74.
- Hagger, M.S., Chatzisarantis, N.L.D., Culverhouse, T., & Biddle, S.J.H. (2003). The processes by which perceived autonomy support in physical education promotes leisure-time physical activity intentions and behavior: A trans-contextual model. *Journal of Educational Psychology, 95*, 784-795.
- Hagger, M.S., Chatzisarantis, N.L.D., Barkoukis, V., & Wang, C.K.J. (2005). Perceived autonomy support in physical education and leisure-time physical activity: A cross-cultural evaluation of the trans-contextual model. *Journal of Educational Psychology, 97*, 376-390.
- Hancock, G.R. (2006). Power analysis in covariance structure models. In G.R. Hancock & R.O. Mueller (Eds.), *Structural equation modeling: A second course*. Greenwood, CT: Information Age Publishing, Inc.
- Hancock, G.R., & Freeman, M.J. (2001). Power and sample size for the RMSEA test of

- not close fit in structural equation modeling. *Educational and Psychological Measurement, 61*, 741-758.
- Hancock, G.R., & Mueller, R.O (Eds.). (2006). Structural equation modeling: A second course. Greenwich, CT: Information Age Publishing, Inc.
- Harackiewicz, J.M., Barron, K., Pintrich, P., Elliot, A.J., & Thrash, T. (2002). Revision of achievement goal theory: Necessary and illuminating. *Journal of Educational Psychology, 94*, 638-645.
- Harp, S. F. & Mayer, R.E. (1998). How seductive details do their damage: A theory of cognitive interest in science learning. *Journal of Educational Psychology, 90*, 414-434.
- Hassamdra, M., Goudas, M., & Chroni, S (2003). Examining factors associated with intrinsic motivation in physical education: a qualitative approach. *Psychology of Sport and Exercise, 4*, 211-223.
- Hergenhahn, B. R., Olson, M. H. (2005). *An introduction to theories of learning*. Pearson Education, NJ.
- Hidi, S. (1990). Interest and its contribution as a mental resource for learning. *Review of Educational Research, 60*, 549-571.
- Hidi, S., & Anderson, V. (1992). Situational interest and its impact on reading and its impact on reading and expository writing. In K.A. Renninger, S. Hidi, & A. Krapp (Eds.), *The role of interest in learning and development* (pp. 43-69). Hillsdale, NJ: Erlbaum.
- Hidi, S., & Baided, W. (1986). Interestingness—a neglected variable in discourse processing. *Cognitive Science, 10*, 179-194.

- Hidi, S., & Harachiewicz, J.M. (2000). Motivating the academically unmotivated: A critical issue for the 21st century. *Review of Educational Research, 70*, 151-179.
- Jacobs, J., Lanza, S., Osgood, D.W., Eccles, J., & Wigfield, A. (2002). Changes in children's self-competence and values: Gender and domain differences across grades one through twelve. *Child Development, 73*, 509-527.
- Jewett, A.E., Bain, L.L., & Ennis, C.D. (1995). *The curriculum process in physical education*. Madison, WI: Brown & Benchmark.
- Jewett, A.E., & Mullan, M.R. (1977). *Curriculum design: purpose and processes in physical education teaching-learning*. American Alliance for Health, Physical Education, and Recreation, Washington, DC.
- Kimble, G.A. (1961). *Hilgard and Marquis 'conditioning and learning.'* East Norwalk, CT: Appleton-Century-Crofts.
- Koka, A., & Hein, V. (2005). The effect of perceived teacher feedback on intrinsic motivation in physical education. *International Journal of Sport Psychology, 36*, 91-106.
- Krapp, A., Hidi, S., & Renninger, K.A. (1992). Interest, learning, and development. In K.A. Renninger, S. Hidi, & A. Krapp (Eds.), *The role of interest in learning and development* (pp. 43-69). Hillsdale, NJ: Erlbaum.
- Lambert (2003). Standard-based program design: Creating a congruent guide for student learning. In S.J. Silverman and C.D. Ennis (Ed.), *Student learning in physical education* (pp. 147-163). Champaign, IL: Human Kinetics.
- Lockhart, A., & McPherson, F.A. (1949). The development of a test of badminton playing ability. *Research Quarterly, 20*, 402-405.

- Loehlin C.J. (2004). *Latent variable models: An introduction to factor, path, and structural equation analysis*. Mahwah, NJ: Lawrence Erlbaum Associates, Inc., Publishers.
- MacCallum, R.C., Browne, M.W., & Sugawara, H.M. (1996). Power analysis and determination of sample size for covariance structure modeling. *Psychological Methods, 1*, 130-149.
- Marteniuk, R.G. (1976). *Information processing in motor skills*. New York: Holt, Rinehart, and Winston.
- McAuley, E., Duncan, T., & Tammen, V.V. (1989). Psychometric properties of the intrinsic motivation inventory in a competitive sport setting: A confirmatory factor analysis. *Research Quarterly for Exercise and Sport, 60*, 48-58.
- Meece, J.L., Wigfield, A., & Eccles, J.S. (1990). Predictors of math anxiety and its consequences for young adolescents' course enrollment intentions and performances in mathematics. *Journal of Educational Psychology, 82*, 60-70.
- Metheny, E. (1975). *Moving and knowing in sport, dance, physical education: A collection of speeches*. Palo Alto, CA: Peek Publications.
- Midgley, C. (1983). Expectancies, values, and academic behaviors. In J.T. Spence (Ed.), *Achievement and Achievement motivation* (pp. 75-146). San Francisco, CA: W. H. Freeman.
- Midgley, C., Kaplan, A., & Middleton, M. (2001). Performance-approach goals: Good for what, for whom, under what circumstances, and at what cost? *Journal of Educational Psychology, 93*, 77-86.
- Miserandino, M (1996). Children who do well in school: Individual differences in perceived

- competence and autonomy in above-average children. *Journal of Educational Psychology*, 88, 203-214.
- Mitchell, M. (1993). Situational interest: Its multifaceted structure in the secondary school mathematics classroom. *Journal of Educational Psychology*, 85, 424-436.
- Montgomery County Public School Middle School Physical Education Curriculum Blueprint (2006). Unpublished Curriculum.
- National Association for Sport and Physical Education [NASPE] (2004). *Moving into the future: National standards for physical education* (2nd ed.) Reston, VA: Author
- Nicholls, J. (1984). Achievement motivation: Conceptions of ability, subjective experience, task choice, and performance. *Psychological Review*, 91, 328-346.
- Ntoumanis, N. (2001). A self-determination approach to the understanding of motivation in physical education. *British Journal of Educational Psychology*, 71, 225-242.
- Ntoumanis, N. (2005). A prospective study of participation in optional school physical education using a self-determination theory framework. *Journal of Educational Psychology*, 97, 444-453.
- Ntoumanis, N., & Pensaard, A., Martin, C., & Pipe, K. (2004). An idiographic analysis of amotivation in compulsory school physical education. *Journal of Sport & Exercise Psychology*, 26, 197-214.
- Oldfather, P., & Dahl, K. (1994). Toward a social constructivist reconceptualization of intrinsic motivation for literacy learning. *JRB: A journal of Literacy*, 28, 129-158.
- Papaopammou, A. (1997). Motivation and goal perspectives in children's physical education. In Biddle, S. *European perspectives on exercise and sport psychology* (p245-269). Champaign, IL: Human Kinetics.
- Parish, L.E., & Treasure, D.C. (2003). Physical activity and situational motivation in

- physical education: Influence of the motivational climate and perceived ability. *Research Quarterly for Exercise and Sport*, 74, 173-182.
- Pintrich, P.R. (2000). Multiple goals, multiple pathway: The role of goal orientation in learning and achievement. *Journal of Educational Psychology*, 92, 544-555.
- Pintrich, P.R. (2003). A motivational science perspective on the role of student motivation in learning and teaching contexts. *Journal of Educational Psychology*, 95, 667-686.
- Pintrich, P. R. & Schunk, D.H. (1996). *Motivation in Education: Theory, Research, and Applications*. Columbus, OH: Prentice Hall.
- Pintrich, P.R., & Schunk, D.H. (2002). *Motivation in education: Theory, research, and applications* (2nd ed.). Upper Saddle River, NJ: Prentice Hall.
- Reeve, J., Nix, G., & Hamm, D. (2003). Testing models of the experience of self-determination in intrinsic motivation and the conundrum of choice. *Journal of Educational Psychology*, 95, 375-392.
- Renninger, K.A. (2000) Individual interest and its implications for understanding intrinsic motivation. In C. Sansone & J.M. Harackiewicz (Eds.), *Intrinsic and extrinsic motivation: The search for optimal motivation and performance* (pp. 373-404). San Diego, CA: Academic Press.
- Renninger, K.A., & Hidi, S. (2002). Student interest and achievement developmental issues raised by a case study. In A. Wigfield & J.S. Eccles (Eds.), *Development of achievement motivation* (pp. 175-196), San Diego, CA: Academic Press.
- Renninger, K.A., Hidi, S., & Krapp, A. (1992). *The role of interest in learning and development*. Hillsdale, NJ: Erlbaum.

- Renninger, K.A., & Leckrone, T.G. (1991). Continuity in young children's actions: A consideration of interest and temperament. In L. Oppenheimer & J. Valsiner (Eds.) *The origins of action: Interdisciplinary and international perspectives* (pp. 205-238). New York: Springer-Verlag.
- Reynold, R. E., Sinatra, G. M., & Jetton, T. (1996). Views of knowledge acquisition and representation: A continuum from experience centered to mind centered. *Educational Psychology, 31* (2), 93-104.
- Richer, S., & Vallerand, R.J. (1998). Construction and validation of the perceived relatedness scale. *Revue Europe'ene de Psychologie Applique'e, 48*, 129-137.
- Rink, (2003). Effective instruction in physical education. In S.J. Silverman and C.D. Ennis (Ed.), *Student learning in physical education* (pp. 147-163). Champaign, IL: Human Kinetics.
- Rink, J.E. (2001). Investigating the assumptions of pedagogy. *Journal of Teaching in Physical Education, 20*, 112-128.
- Ryan, R.M. & Connell, J.P. (1989). Perceived locus of causality and internalization: Examining reasons for acting in two domains. *Journal of Personality and Social Psychology, 57*, 749-761.
- Ryan, R.M., & Deci, E.L. (2000a). Self-determination theory and the facilitation of intrinsic, social development, and well-being. *American Psychologist, 55* (1), 68-78.
- Ryan, R.M. & Deci, E. (2000b). Intrinsic and extrinsic motivation: Classic definitions and new directions. *Contemporary Educational Psychology, 25*, 54-67.
- Ryan, R.M., & Deci, E.L. (2000c). When rewards compete with nature: The undermining

- of intrinsic motivation and self-regulation. In C. Sansone & J.M. Harackiewicz (Eds.), *Intrinsic and Extrinsic Motivation: The search for optimal motivation and performance* (pp. 14-56), San Diego, CA: Academic Press.
- Ryan, R.M. & Powelson, C.L. (1991). Autonomy and relatedness as fundamental to motivation and education. *Journal of Experimental Education*, 60 (1), 49-66.
- Sansone, C., & Harackiewicz, J. (2000). *Intrinsic and extrinsic motivation: The search for optimal motivation and performance*. San Diego, CA: Academic Press.
- Sarrazin, P., Roberts, G., Cury, F., Biddle, S., & Famose, J.P. (2002). Exerted effort and performance in climbing among boys: The influence of achievement goals, perceived ability, and task difficulty. *Research Quarterly for Exercise and Sport*, 73, 425-436.
- Schiefele, U. (1999). Interest and learning from text. *Science Study Read*, 3, 257-280.
- Schmidt, R. (1991). *Motor learning & performance: From principles to practice*. Champaign, IL: Human Kinetics.
- Schmidt, R.A., & Wrisberg, C.A. (2000). *Motor learning and performance*. Human Kinetics.
- Schunk, D.H., & Pajares, F. (2002). The development of academic self-efficacy. In A. Wigfield & J.S. Eccles (Eds.), *Development of achievement motivation* (pp. 16-32), San Diego, CA: Academic Press.
- Schraw, G. (1997). Situational interest in literary text. *Contemporary Education Psychology*, 22, 436-456.
- Schraw, G. (1998). Processing and recall differences among seductive details. *Journal of Educational Psychology*, 90, 3-12.

- Schraw, G., Bruning, R., & Svoboda, C. (1995). Sources of situational interest. *Journal of Reading Behavior, 27*, 1-17.
- Schraw, G. & Dennison, R.S. (1994). The effect of reader purpose on interest and recall. *Journal of Reading Behavior, 26*, 1-18.
- Schraw, G., Flowerday, T., & Lehman, S. (2001). Increasing situational interest in the classroom. *Educational Psychology Review, 12*, 211-224.
- Schraw, G. & Lehman, S (2001). Situational Interest: A review of the literature and directions for future research. *Educational Psychology Review, 13 (1)*, 23-52.
- Shen, B., & Chen, A. (2006). Examining the interrelations among knowledge, interests, and learning strategies. *Journal of Teaching in Physical Education, 25*, 182
- Shen, B., Chen, A., Scrabis, K.A., & Tolley, H. (2003). Gender and interest-based motivation in learning dance. *Journal of Teaching in Physical Education, 22*, 396-410.
- Shuell, T.J. (1986). Cognitive conceptions of learning. *Review of Educational Research, 56*, 411-436.
- Siegler, R.S. (1998). Information processing theories of development. In R.S. Siegler (Eds.). *Children's thinking*. Upper Saddle River: Prentice-Hall
- Skinner, B.F. (1957). *Verbal behavior*. New York: Appleton.
- Solmon, M.A. (1997, March). Students' goals in physical education classes. Paper presented at the annual meeting of the American Educational Research Association, Chicago.
- Solmon, M.A., & Boone, J. (1993). The impact of student goal orientation in physical education classes. *Research Quarterly for Exercise and Sport, 64*, 418-424.

- Standage, M., Duda, J.L., & Ntoumanis, N. (2003a). A model of contextual motivation in physical education: Using constructs from self-determination and achievement goal theories to predict physical activity intentions. *Journal of Education Psychology, 95*, 97-110.
- Standage, M., Duda, J.L., & Ntoumanis, N. (2003b). Predicting motivational regulations in physical education: The interplay between dispositional goal orientations, motivational climate and perceived competence. *Journal of Sport Sciences, 21*, 631-647.
- Standage, M., Duda, J.L., & Ntoumanis, N. (2005). A test of self-determination theory in school physical education. *British Journal of Educational Psychology, 75*, 411-433.
- Steiger, J.H., & Lind, J.M. (1980, June). *Statistically based tests for the number of common factors*. Paper presented at the annual meeting of the psychometric society, Iowa City, IA.
- Sun, H., Chen, A., Ennis, C., Kim, S., Bonello, M., Hopple, C., & Bae, M. (2006). Curriculum matters: Situational interest and learning in elementary school physical education. *Research Quarterly for Exercise and Sport, 77 (1) Supplement*, 70.
- Thomas, J.A. & Barron, K.E. (2006). A test of multiple achievement goal benefits in physical education activities. *Journal of Applied Sport Psychology, 18*, 114-135.
- Todorovich, J.R., & Curtner-Smith, M.D. (2003). Influence of the motivational climate in physical education in third-grade students' task and ego orientation. *Journal of Classroom Interaction, 38*, 36-46.

- Treasure, D. (2001). Enhancing young people's motivation in youth sport: An achievement goal perspective. In G.C. Roberts (Ed.), *Advances in motivation in sport and exercise* (2nd ed., pp.263-319). Champaign, IL: Human Kinetics.
- Urduan, T.C. (1997). Achievement goal theory: Past results, future direction. In M.L. Maehr & P.R. Pintrich (Eds.), *Advances in motivation and achievement, Vol. 10* (pp. 99-141). Greenwich, CT: JAI Press.
- Vallerand, R.J., & Losier, G.F. (1999). An integrative analysis of intrinsic and extrinsic motivation in sport. *Journal of Applied Sport Psychology, 11*, 142-169.
- Vallerand, R.J., & Rousseau, F.L. (2001). Intrinsic and extrinsic motivation in sport and exercise: A review using the hierarchical model of intrinsic and extrinsic motivation. In R.N. Singer, H.A. Hausenblas, & C.M. Janelle (Eds.), *Handbook of sport psychology* (2nd ed., pp.389-416). New York: Wiley.
- Van Wersch, A., Trew, K., & Turner, I. (1992). Post-primary school pupil's interest in physical education: Age and gender differences. *British Journal of Educational Psychology, 62*, 56-72.
- Vygotsky, L. S. (1978). *Mind in society: The development of higher psychological processes*. Cambridge, MA: Harvard University Press.
- Wade, S.E., Buxton, W.M., & Kelly, M. (1999). Using think-alouds to examine reader-text interest. *Reading Research Quarterly, 30*, 512-515.
- Wang, C.K.J., Chatzisarantis, N.L.D., Spray, C.M., & Biddle, S.J.H. (2002). Achievement goal profiles in school physical education: Differences in self-determination, sport ability beliefs, and physical activity. *British Journal of Educational Psychology, 72*, 433-445.

- Wendell, S. (1992). Physical education: part of the learning process. *Clearing Housing*, 66 (1), ERIC
- Wentzel, K.R. (1993). Motivation and achievement in early adolescence: the role of multiple classroom goals. *Journal of Adolescence*, 13 (1), 4-20.
- Wentzel, K.R. (1996). Motivation in context: Social relationships and achievement in middle school. In J. Juvonen & K. R. Wentzel (Eds.) *Social motivation: Understanding children's school adjustment*. New York: Cambridge University Press.
- Wentzel (1997). Student motivation in middle school: The role of perceived pedagogical caring. *Journal of Educational Psychology*, 89, 411-419.
- Wentzel, K.R. (1999). Social-motivational processes and interpersonal relationships: Implications for understanding students' academic success. *Journal of Educational Psychology*, 91, 76-97.
- Wentzel, K.R. (2000). What is it that I am trying to achieve? Classroom goals from a content perspective. *Contemporary Educational Psychology*, 25, 105-115.
- Wentzel, K.R. (2002). Are effective teachers like good parents? Teaching styles and student adjustment in early adolescence. *Child Development*, 73, 287-301.
- Wentzel, K.R. & Watkins, D.E. (2002). Peer relationships and collaborative learning as contexts for academic enablers. *School Psychology Review*, 31, 366-377.
- Wigfield, A., & Eccles, J. (1992). The development of achievement task values: A theoretical analysis. *Development Review*, 12, 265-310.
- Wigfield, A. & Eccles, J.S. (2000). Expectancy-value theory of achievement motivation. *Contemporary Educational Psychology*, 25, 68-81.

- Wigfield, A. & Eccles, J.S. (2002). The development of competence beliefs, expectancies for success, and achievement values from childhood through adolescence. In A. Wigfield & J.S. Eccles (Eds.), *Development of achievement motivation* (pp. 1-10), San Diego, CA: Academic Press.
- Wigfield, A., Eccles, J., Maclver, D., Reuman, D., & Midgley, C. (1991). Transitions at early adolescence: Changes in children's domain-specific self-perceptions and general self-esteem across the transition to junior high school. *Developmental Psychology, 27*, 552-565.
- Wigfield, A., Eccle, J.S., & Rodrigues, D. (1998). The development of children's motivation in school context. *Review of Research in Education, 23*, 73-118.
- Wigfield, A., Eccles, J. S., Yoon, K.S., Harold, R.D., Arbreton, A., Freedman-Doan, C., Blumenfeld, P.C. (1997). Changes in children's competence beliefs and subjective task values across the elementary school year: A three-year study. *Journal of Educational Psychology, 89*, 451-469.
- Wigfield, A., Lutz, S.L., & Wagner, A.L. (2005). Early adolescents' development across the middle school years: Implication for school counselors. *Professional School Counseling, 9* (2), 112-119.
- William, G.C., & Deci, E.L. (1996). Internalization of biopsychosocial values by medical students. *Journal of Personality and Social Psychology, 70*, 767-779.
- Windholz, G. (1992). Pavlov's conceptualization of learning. *The American Journal of Psychology, 105*, 459-469.
- Xiang, P., McBride, R., & Bruene, A. (2004). Fourth graders' motivation in an

- elementary physical education running program. *Elementary School Journal*, 104, 253-266.
- Xiang, P., McBride, R., & Bruene, A. (2006). Fourth graders' motivational changes in an elementary physical education running program. *Research Quarterly for Exercise and Sport*, 77, 195-207.
- Xiang, P., McBride, R., & Guan, J. (2004). Children's motivation in elementary physical education: a longitudinal study. *Research Quarterly for Exercise and Sport*, 75, 71-80.
- Xiang, P., McBride, R., Guan, J., & Solmon, M. (2003). Children's motivation in elementary physical education: An expectancy-value model of achievement choice. *Research Quarterly for Exercise and Sport*, 74, 25-36.
- Zhu, W., Safrit, M., & Cohen, A. (1999). *Fit Smart: The national health-related physical fitness knowledge test*. Champaign, IL: Human Kinetics.