

ABSTRACT

Title of Dissertation: THE INTERRELATIONSHIP BETWEEN CD14 AND LPS DURING MASTITIS: RELEASE OF SOLUBLE CD14 AND CYTOKINES BY BOVINE PMN FOLLOWING ACTIVATION WITH LPS

Eun Jung Sohn, Doctor of Philosophy, 2005

Dissertation directed by: Dr. Robert R. Peters
Department of Animal and Avian Sciences
Graduate Program in ADVP

Understanding the immune defense of the mammary gland is important in devising and developing measures to control mastitis. Lipopolysaccharide (LPS) is the predominant factor causing pathogenesis in Gram-negative bacterial infections. The cluster of differential antigen14 (CD14), which is located on the surface of leukocytes, is the receptor for LPS. The binding of LPS to CD14 results in release of pro-inflammatory cytokines that recruit polymorphonuclear neutrophil leukocytes (PMNs), to the site of inflammation, allowing them to kill bacteria through the process of phagocytosis. This research was designed to produce and characterize monoclonal antibodies (mAb) against recombinant bovine soluble (rbos) CD14, express rbosCD14 in plants and characterize the biological activity of plant-derived rbosCD14 *in vitro* and *in vivo*. The release of inflammatory cytokines and expression of CD14 on bovine PMN and the secretion of IL-8 by PMN in response to LPS was also investigated.

A panel of ten murine mAb reactive with rbosCD14 were produced and a sandwich ELISA was developed using the mAbs and rabbit polyclonal antibodies. The mAbs recognized rbosCD14 (40 kDa), solubleCD14 (sCD14) (53 and 58 kDa) in milk and blood, and a 47 kDa mCD14 in lysates of macrophages obtained from involuted bovine mammary gland secretions by Western blot analysis. Flow cytometric analysis showed that the mAb bound to macrophages isolated from involuted mammary gland secretions. The addition of anti-rbosCD14 mAb to monocytes stimulated with LPS reduced TNF- α production *in vitro*. The anti-rbosCD14 mAbs generated in this study will be useful in studying CD14, an accessory molecule that contributes to host innate recognition of bacterial cell wall components in mammary secretion produced during mastitis.

This study demonstrates the functional activity of a recombinant animal receptor protein made in plants, and the use of a plant-derived protein as a potential animal therapeutic for bacterial infections. A truncated form of sCD14, carrying a histidine residue affinity tag was incorporated with potato virus X for transient expression in *Nicotiana benthamiana*. CD14 from crude plant extracts was recognized by Western blot analysis. Biological activities of plant-derived rbosCD14 (prbosCD14) were characterized *in vitro* and *in vivo*. Biological activity of prbosCD14 demonstrated *in vitro* by LPS-induced apoptosis, an increase of caspase activity and IL-8 production by bovine endothelial cells. *In vivo*, prbosCD14 enhanced LPS-induced PMN recruitment and in bovine mammary quarters challenged with *Escherichia coli* that resulted in decreased bacterial counts and elimination of clinical symptoms.

In this dissertation, shedding of sCD14 from the surface of PMN in response to LPS was negatively correlated with IL-8 release. Shedding of sCD14 from the surface of

PMN increased in the absence of serum and at high concentrations of LPS. The use of real time RT-PCR showed that CD14 gene expression was not different between control and the LPS stimulated cells. This demonstrates that shedding of sCD14 comes from membrane-bound CD14 (mCD14). However, in contrast to the shedding of sCD14, IL-8 secretion by PMN was decreased at high concentrations of LPS in the absence of serum. Moreover, sCD14 secretion from PMN stimulated with LPS was increased in parallel with the decrease of IL-8 secretion at varying PMN cell densities. This result suggests that the release of CD14 leads to the down-regulation of IL-8 secretion by PMN in response to LPS.

Bovine PMN produced different types of cytokines in response to LPS in this dissertation. The secretion of TNF- α , IL-1 β , IL-8 and INF- γ by PMN increased in a dose-dependent manner, but IL-12 secretion by PMN was decreased with increasing concentrations of LPS. Co-incubation of LPS with either TNF- α or IL-1 β increased secretion of IL-8 when compared to LPS alone.

These studies contribute to a better understanding of the interrelationship between bovine CD14 and LPS during mastitis and provide new insights into events that resolve inflammation following bovine PMN activation.

THE INTERRELATIONSHIP BETWEEN CD14 AND LPS DURING MASTITIS:
RELEASE OF SOLUBLE CD14 AND CYTOKINES BY BOVINE PMN
FOLLOWING ACTIVATON WITH LPS

by

Eun J. Sohn

Dissertation submitted to the Faculty of the Graduate School of the
University of Maryland, College Park in Partial fulfillment
of the requirements for the degree of
Doctor of Philosophy
2005

Advisory Committee:

Professor Robert R. Peters, Chair

Adjunct Professor Max J. Paape, Research Advisor

Professor David M. Mosser

Assistant Professor Brooke D. Humphrey

Research Scientist Raymound H. Fetterer

©Copyright by
Eun Jung Sohn
2005

DEDICATION

I dedicate this dissertation to my family

ACKNOWLEDGEMENT

I would like to thank my family, friends, and advisory committee. My deepest gratitude goes to Dr. Max Paape for his patience, support and encouragement. I enjoyed working with him through the years. I would like to thank Dr. Robert Peters for his advice and encouragement. I would like to thank Dr. Douglase Bannerman, Dr. Ray Fetterers, and Dr. Erine Conner for advice and support. Sincere thanks are extended to committee members for the critical review of this dissertation. I would like to thank Mary Bowman, Jennifer Bilheimer, Elisabeth Cates and Anna Chockalingham for their friendship and support through the years.

The financial and material support provided by the University of Maryland in cooperation with the U.S. Department of Agriculture, Science and Education Administration, Agricultural Research Service is also gratefully acknowledged.

TABLE OF CONTENTS

<u>Sections</u>	<u>Pages</u>
List of Tables	vi
List of Figures	vii
List of Abbreviations	x
Chapter One: Literature Review	1
Introduction.....	1
Background.....	2
The Structure and Host Response to LPS	
LPS Recognition; LBP, CD14 and Toll like receptor	
Biological Function of CD14	
Defense of Bovine Mammary Gland by PMN	
The Characteristic of PMN	
PMN Migration from Blood to the Mammary Gland	
Phagocytosis and Intracellular Killer	
The Role of Cytokines in the Mammary Gland	
Transgenic Plants	
Objectives.....	18
Chapter Two: The Production and Characterization of Anti-bovine CD14	
Monoclonal Antibodies.....	19
Abstract.....	19
Introduction.....	20
Materials and Methods.....	21
Results.....	31
Discussion.....	33
Chapter Three: Expression of a Functional Bovine CD14 Receptor in Plants	43
Abstract	43
Introduction.....	44
Materials and Methods.....	45
Results.....	50
Discussion.....	54
Chapter Four: Shedding of sCD14 by Bovine Neutrophils Following Activation	
with LPS Results in Down-Regulation of IL-8.....	65
Abstract.....	65
Introduction.....	66
Materials and Methods.....	68
Results.....	72
Discussion.....	76
Chapter Five: Cytokine Production by Bovine Neutrophils Stimulated with LPS ..	94

Abstract.....	94
Introduction.....	95
Material and Methods.....	96
Results.....	99
Discussion.....	101
Chapter Six: General Discussion.....	110
Chapter Seven: Conclusions.....	113
Literature Cited.....	116

LIST OF TABLES

<u>Number</u>	<u>Page</u>
Table I. Immunoglobulin isotype and results from ELISA and Western blotting analysis for the ten murine anti rboS CD14 mAb developed in this study.....	36
Table II. Reactivity of murine anti-rboS CD14 mAb with macrophages isolated from involuted bovine mammary glands (n = 2 cows) as measured by flow cytometry.....	37
Table III. INF- γ secretion by bovine PMN after stimulation with LPS (0.1 μ g/mL) and bovine IL-12 (5 ng/mL) in the presence and absence of 5% FBS..	104

LIST OF FIGURES

<u>Number</u>	<u>Pages</u>
Figure 1. Model of the inner and outer membranes of <i>E. coli K-12</i>	4
Figure 2. Binding of the LPS-binding protein/LPS complex to mCD14 on monocytes and macrophage causes release of TNF- α and binding of the sCD14/LPS complex to Toll receptors on endothelial and epithelial cells causes release of chemoattracts.....	9
Figure 3. Recognition of bacteria through immunological receptor recognition (CR1, CR3 and FC) and non-immunological recognition mechanisms (lectin, carbohydrate and hydrophobic interaction) on the surface of PMN.....	13
Figure 4. Representative ELISA results for the anti-rbosCD14 developed in this study for mAb M1-6-6.....	38
Figure 5. A sandwich ELISA was used to quantify sCD14 in milk obtained from mammary quarters of cows that received either saline or LPS	39
Figure 6. Representative Western blotting analysis using mAb M5-29-3 showing identification of 53 and 58 kDa proteins, indicated by arrows, in milk whey (lane 1) in blood plasma (lane 2) and a 40 kDa protein in rbosCD14 (lane 3)	40
Figure 7. Representative Western blotting analysis of a macrophage lysate (Lys) using anti-rbosCD14 mAb.....	41
Figure 8. Anti-rbosCD14 mAb inhibits TNF- α response of monocytes after stimulation with LPS.....	42
Figure 9. Structure of the truncated rbosCD14, lacking the 33 3' terminal amino acids, incorporated into the PVX pP2C2S vector. The ATG codon was placed in the surrounding plant translational consensus sequence (bold); an extra TAA stop codon was introduced at the 3' terminus (bold).....	56
Figure 10. Western blotting analysis of samples from PVX/CD14-infected plants, probed with CD14-specific polyclonal antisera.	57
Figure 11. Effect of plant-derived rbosCD14 on LPS-induced IL-8 production and caspase activation. Bovine aortic endothelial cells were exposed to PBS or LPS (100 ng/mL) for 16 h in the presence or absence of serum, or in serum-free media containing insect cell-or plant-derived rbosCD14 (250 ng/mL).....	58

Figure 12. Effect of plant-derived rbosCD14 on apoptosis of bovie endothelial cells.....	60
Figure 13. Plant-derived rbosCD14 on LPS-induced increases in milk somatic cell counts (SCC).....	63
Figure 14. Effect of plant-derived rbosCD14 on colony forming units of <i>E. coli</i> after intramammary challenge.....	64
Figure 15. Percentage of apoptotic PMN (5×10^6 PMN/mL) following 6 h of incubation without FBS and varying concentration of LPS.....	81
Figure 16. Percentage of apoptotic PMN (5×10^6 PMN/mL) following 20 h of incubation with varying concentrations of LPS in the absence (A) or presence (B) of FBS	82
Figure 17. LPS (100 μ g/mL) decreased percentage of PMN expressing mCD14 when compared to media control (A) and increased when stimulated with 1 μ g/mL in the presence of FBS (B).	83
Figure 18. Expression of CD14 mRNA in PMN in response to LPS in the presence or absence of FBS.....	84
Figure 19. LPS treatment resulted in enhanced CD18 expression on PMN in either the presence or absence of 5% FBS.....	85
Figure 20. Release of sCD14 from PMN in the absence (A) or presence of FBS (B) after 20 h of incubation with different concentrations of LPS	86
Figure 21. Concentration of sCD14 in supernatants after stimulation of PMN with 100 μ g/mL of LPS in the absence of FBS after 6,16, 20 h of incubation.....	87
Figure 22. Release of IL-8 from PMN in the absence (A) or presence of FBS (B) after 20 h of incubation with different concentrations of LPS.....	88
Figure 23. Effect of PMN concentration on release of sCD14 (A) and secretion of IL-8 (B) in response to 10 μ g/mL of LPS in the absence of FBS.....	89
Figure 24. Effect of PMN concentration on release of sCD14 (A) and secretion of IL-8 (B) in response to 0.1 μ g/mL LPS in the absence of FBS.....	90
Figure 25. Release of PGE ₂ from PMN (5×10^6 PMN/mL) in the absence (A) or presence (B) of FBS after 20 h of incubation with different concentrations of LPS in RPMI media. Effect of cell density of PMN on PGE ₂ secretion	

in response to 0.1 $\mu\text{g/mL}$ of LPS in the absence of FBS (C).....	91
Figure 26. The expression of L-selectin on PMN (5×10^6 PMN/mL) in the absence and presence of FBS after 20 h of incubation with different concentrations of LPS (A). Effect of cell density of PMN on L-selectin expression in response to 0.1 $\mu\text{g/mL}$ LPS in the absence of FBS (B).....	93
Figure 27. The effect of different stimuli on IL-8 release from bovine PMN (4×10^6 PMN/mL). PMN were incubated with RPMI, hTNF- α (10 ng/mL), bIL-1 β (10 ng/mL), LPS (0.1 $\mu\text{g/mL}$), hTNF- α (10 ng/mL) + LPS (0.1 $\mu\text{g/mL}$), bIL-1 β (10 ng/mL) + LPS (0.1 $\mu\text{g/mL}$).....	105
Figure 28. Concentration of IFN- γ in supernatants after incubation of PMN with LPS.....	106
Figure 29. Concentration of IL-1 β in supernatants after incubation of PMN with LPS in the absence or presence of 5% FBS.....	107
Figure 30. Concentration of IL-12 in supernatants after incubation of PMN with LPS.....	108
Figure 31. Concentration of TNF- α in supernatants after incubation of PMN with LPS.....	109
Figure 32. Schematic drawing of the objectives of this thesis.	114

LIST OF ABBREVIATIONS

ANOVA.....	one-way analysis of variance
BSA	bovine serum albumin
BPI.....	bactericidal permeability increasing protein
BCIP/NBT.....	bromo-4-chloro-3-indolyl-phosphate/nitroblue tetrazolium
CD.....	cluster of differential antigen
CFU.....	colony forming unit
CR.....	complement receptor
CSF.....	colony stimulating factor
CXCR.....	chemokine receptor
DMEM/H.....	Dulbecco's modified Eagle's medium with 4.5 g/L glucose (high glucose) supplemented with 10% fetal bovine serum, 2 mM glutamine, and 50 U/mL penicillin/streptomycin
dpi.....	days post inoculation
ELISA.....	enzyme linked immorsorbent assay
FBS.....	fetal bovine serum
FcR.....	Fc receptor
FITC.....	fluorescein isothiocyanate
FMLP.....	N-formyl-methionyl-leucyl-phenylalanine
FPLC.....	fast protein liquid chromatography
G-CSF.....	granulocytes-CFS
GDF.....	growth differentiation factor
GlcN.....	glucosamine
Glc.....	glucose
GM-CSF.....	granulocyte-macrophage CSF
GPI.....	glycosyl-phosphatidyinositol tail
h.....	hour
HBSS.....	Hank's balanced salt solution
Hex.....	hexose
HPRT.....	hypoxanthine phsphoribosyltransferase
HSP.....	heat shock protein
Ig.....	immunoglobulin
ICAM.....	intercellular adhesion molecular
kDa.....	kilo dalton
Kdo.....	3-deoxy-D- <i>manno</i> -oct-2-ulosonic acid
MAPK.....	mitogen-actviated protein kinase
INF.....	interferons
IL.....	interleukins
LPS.....	lipopolysaccharide
LBP.....	LPS-binding protein
LMFC.....	log mean fluorescent channel
LTA.....	lipoteichoic acid
m-CSF.....	macrophage-CSF
mAb.....	monoclonal antibodies
mCD14.....	membrane bound CD14
MEF/MAC.....	mouse fibroblast/macrophages

Min.....	minutes
MYD88.....	myeloid differentiation factor 88
MSCC.....	milk somatic cell counts
NF- κ B.....	nuclear factor- κ B
NK.....	natural killer cells
OD.....	optical density
PBS.....	phosphate buffered saline
PBS-T.....	PBS containing 0.05% (v/v) Tween 20
PEtN.....	2-aminoethyl phosphate
SCC.....	somatic cells counts
sCD14.....	solubleCD14
SDS-PAGE.....	sodium dodecyl sulfate polyacrylamide gel electrophoresis
SE.....	standard error
TBS.....	tris buffered saline
TIR.....	toll and interleukin-1 receptor
TLR.....	toll-like receptor
PMN.....	polymorphonuclear neutrophil leukocytes
ProbsCD14.....	plant-derived solubleCD14
PTLP.....	phospholipid transfer protein
PVX.....	potato virus X
rbos CD14.....	recombinant bovine CD14
RTPCR.....	reverse transcriptase polymerase chain reaction
RPMI.....	Roswell Park Memorial Institute medium
RNA.....	ribonucleic acid
TNF.....	tryptic soy broth
TMB.....	tetramethylbenzidine

Chapter One: Literature Review

INTRODUCTION

Bovine coliform mastitis is the most costly disease in dairy cows (145). Despite major successes in the reduction in prevalence of intramammary infections, clinical mastitis due to *Escherichia coli*, environmental streptococci, and *Staphylococcus aureus* remains an important problem (47, 79, 218). *E. coli* is the most common Gram-negative pathogen (193). About 80% of coliform infection will result in clinical mastitis, and 10% will result in acute mastitis with a sudden onset of septic shock. Clinical mastitis causes decreased milk production, increased veterinary costs, and possible death or culling (145). Although several strategies such as improved herd sanitation, antibiotic therapy, and vaccination have been developed to reduce the occurrence of mastitis, they are not effective in preventing or eliminating infections.

Gram-negative bacteria possess lipopolysaccharides or endotoxins, which form part of the outer layer of the cell wall. Once infection has occurred, the *E. coli* bacteria proliferate in great numbers and produce endotoxin. The release of this endotoxin triggers a cascade of inflammatory responses resulting in acute swelling of the mammary gland and a marked increase in the number of neutrophils in the milk (195). The cluster of differentiation antigen 14 (CD14)-mediated response to LPS, is an important pathway utilized by the host for activating cells to LPS. The role of bovine CD14 to LPS has not been fully defined, but previous studies have shown that the intramammary co-administration of sCD14 with an inoculum of *E. coli* enhanced bacterial clearance and an early influx of white blood cells (118, 119). The purpose of this research is to provide a better understanding of the interrelationship between CD14 and LPS by using anti-

rbosCD14 mAb, and explore the possibility of using a plant-derived CD14 protein as a potential animal therapeutic for bacterial infection.

Polymorphonuclear neutrophil leukocytes (PMN) play a key role in a cow's defense against intramammary infection by *E. coli* (27). Effective elimination of the pathogen by PMN is important for the resolution of infection and the outcome of *E. coli* mastitis (237). PMN and macrophages are the functional phagocytic cells of the body. Macrophage and epithelial cells initiate the inflammatory response necessary to eliminate invading bacteria. These cells release chemoattractants for rapid recruitment of PMN to foci of infection. Initiation of the inflammatory reaction is caused by the production and release of tumor necrosis factor (TNF), interferons (INF), and interleukins (IL). These complex interactions result in accumulation of PMN in the mammary gland. Phagocytosis by PMN is the most effective defense against bacterial infection. However, the release of pro-inflammatory cytokine producing by bovine PMN is not. Studies in my thesis suggest that in addition to their phagocytic and bactericidal properties, PMN may play a supportive role by producing pro-inflammatory cytokine and CD14 in the innate immune response to infection by Gram-negative bacteria.

BACKGROUND

1. The structure and host response of LPS

The rapid and vigorous inflammatory response to toxic bacterial cell wall products, such as LPS, is part of the host innate immune response, which provides the first line of defense against invading pathogens (188, 217).

LPS is a component of the outer leaflet of the outer membrane of Gram-negative bacteria such as *E. coli*. LPS is a highly pro-inflammatory molecule that is shed from the bacterial surface during bacterial replication or death. LPS molecules from these Gram-negative bacteria are divided into three distinct regions: a hydrophobic membrane anchor designated lipid A, a short chain of sugar residues with multiple phosphoryl substituents, referred to as the core oligosaccharide, and a structurally diverse, serospecific polymer composed of oligosaccharide repeats, termed the O antigen (Figure 1).

Lipid A functions as a membrane anchor for LPS molecules, and is also known to be responsible for the variety of biological effects observed in mammals during Gram-negative sepsis. There are 10^6 lipid A residues and 10^7 glycerophospholipids in a single cell of *E. coli*. LPS has become synonymous with “endotoxin”, as a reflection of these biological properties of lipid A portion of the molecule. Lipid A-related bioactivities include endotoxic shock, generation of fever, and non-specific activation of host lymphocytes and macrophages (166).

O antigens are made up of repeating oligosaccharide units and are attached via specific sugars in the outer core to the lipid A membrane anchor. An enormous number of O antigen structures results from variability within the repeat unit in the type, linkage, and substitution of its component sugars, which make the vast serological diversity observed for *E. coli*. For instance, more than 170 different O antigens have been identified in *E. coli* (94).

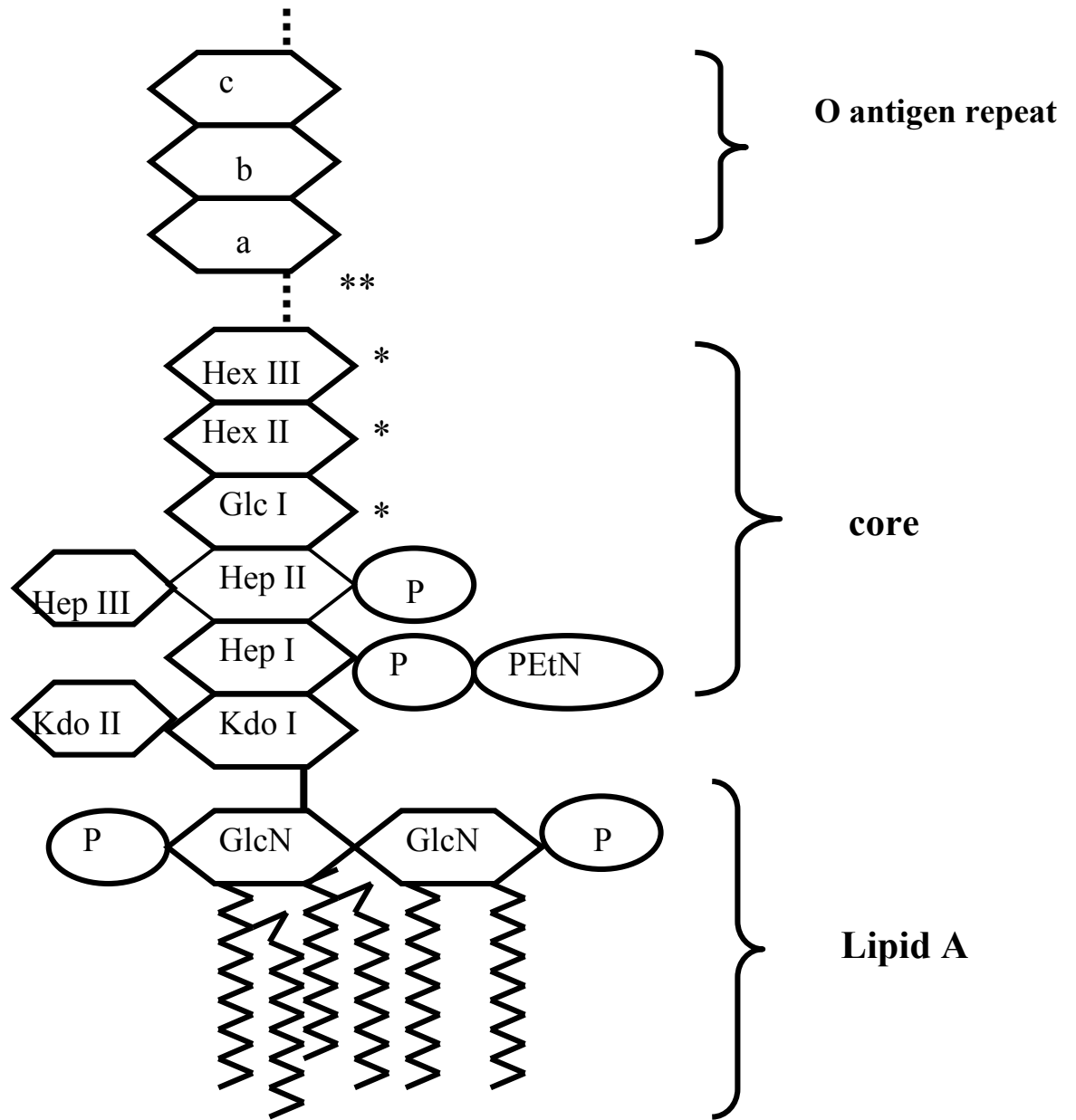

Figure 1. Generalized structure of the LPS of *E. coli*. Core sugar residues are designated by sugar abbreviation and number to facilitate identification. (*): Depending upon the core type, there can be sugar substituents branching out from the main carbohydrate backbone at these locations. (**): The linkage point for O antigen to the core can vary. The number of O antigen repeats generally numbers between 1 and 40. This is based on the review paper (230).

LPS induces a cascade of host responses including the production of pro-inflammatory cytokines and mediators, and activation of complement and coagulation systems. LPS activates monocytes and macrophages to produce pro-inflammatory cytokines such as TNF- α , IL-1 and IL-6, which serve as endogenous mediators of inflammation through receptor-mediated interactions with various target cells. Pro-inflammatory cytokines and mediators further stimulate the hypothalamic-pituitary-adrenal axis, and results in metabolic changes of the host such as onset of the acute phase response for maintaining homeostasis during Gram-negative bacterial infections (20).

Although cytokine production is important for the efficient control of growth and dissemination of invading pathogens, overproduction of cytokines is harmful for the host. High concentrations of TNF results in dramatic pathophysiological reactions such as fever, leucopenia, hypotension, disseminated intravascular coagulation, and multi-organ failure observed in septic shock syndrome (178). In contrast during sepsis, endotoxin tolerance may represent a protective mechanism whose primary function is to limit inflammatory damage due to excessive activation of monocytes and macrophages by LPS and prevent development of septic shock (167, 200).

The most common Gram-negative pathogens implicated in bovine mastitis are *E. coli*, *Klebsiella pneumoniae*, and various species of *Enterobacter* (60, 61). LPS is found in the outer membrane of these bacteria. The bovine mammary gland is highly sensitive to LPS (31, 136). Mastitis may be induced by intramammary injection of LPS-derived from *E. coli* 026:B6, 055:B5, or 0111:B4 (98, 136, 156, 219) and LPS is detectable in the milk of cows with coliform mastitis (5, 81). Absorption of LPS into the blood during

experimentally induced (58) and naturally occurring *E. coli* mastitis (103) has been reported.

II. LPS recognition: LBP, CD14 and Toll like receptor

The first host protein involved in LPS recognition is LBP (LPS binding protein) (182). LBP, a glycosylated 58-kDa protein, is an acute-phase protein produced in the liver that circulates in the bloodstream where it recognizes and forms a high-affinity complex with the lipid A moiety of LPS, as either free molecules, fragments or bound to the outer membrane of intact bacteria (182, 210, 226).

LBP belongs to a family of lipid-binding proteins, which include bactericidal permeability increasing protein, cholesterol ester transfer protein and phospholipid transfer protein. LBP is normally found in plasma in low ($\mu\text{g/ml}$) concentrations, but increases by up to 30-fold in plasma during the acute-phase response. The concentration of bovine LBP in milk was reported to be about $6 \mu\text{g/mL}$ (14).

The role of LBP appears to be that of aiding LPS to dock at the LPS receptor complex by initially binding LPS, and then forming a ternary complex with CD14. This enables LPS to be transferred to the LPS receptor complex composed of Toll like receptor (TLR) 4. Transmembrane signals are generated to affect cellular functions and myeloid differentiation protein (MD)-2 (82, 211) (Figure 2). LBP alone does not stimulate macrophages, or initiate signal transduction pathways in macrophages and PMN (83).

CD14 is found in two forms. The first is solubleCD14 (sCD14), which occurs in plasma where it helps to convey LPS signaling in cells lacking membrane-bound CD14

(mCD14) e.g, endothelial and epithelial cells (Figure 2). The second and more extensively studied form of CD14 is mCD14, attached to the surface of myeloid cells via glycosylphosphatidylinositol tail (GPI) (91), enabling CD14 to be membrane proximal despite lacking a transmembrane domain. CD14 is also required for the recognition of other bacterial products including peptidoglycan, lipoteichoic acid (LTA), and lipoarabinomannan (80, 162, 177).

TLRs have been identified as a major class of receptors recognizing conserved bacterial structures called pathogenesis associated molecular patterns. The main bacterial ligands for TLR2 are peptidoglycan and LTA of Gram-positive bacteria. TLR4 recognizes LPS of Gram-negative bacteria and LTA. Each TLR5 and TLR9 recognizes bacterial flagellin and bacterial CpG DNA, respectively (234).

TLRs support CD14-dependent LPS signaling. The binding of LPS to mCD14 is facilitated by LBP. mCD14-LPS-LBP complex is recognized by TLR4 (Figure 2). sCD4 can efficiently present LPS to TLR4 or peptidoglycan to TLR2 on endothelial and epithelial cells that do not express mCD14. Transmembrane signaling is mediated by TLR, where cascades of activation are set in motion, leading to the activation of nuclear factor- κ B (NF κ B), activated protein-1, mitogen activated protein kinase (MAPK), and p38. This signaling results in cellular activation and production of pro-inflammatory cytokines (TNF- α , IL-1, IL-6, IL-12), oxygen radicals, nitric oxide, tissue factors, as well as anti-inflammatory cytokines like IL-10 and transforming growth factor (TGF). Biological effects induced by LPS are primarily mediated by the cytokines TNF- α and IL-6 produced by mononuclear phagocytes and known to be involved in septic shock (22, 114), and by IL-8, which is a chemoattractant for PMN and granulocyte-activating cytokines (148).

Monocytes presented with LPS have a markedly reduced capacity to produce pro-inflammatory cytokines (especially TNF- α) in response to a second LPS stimulation (96). Reduced TNF- α production in septic shock patients was clearly associated with reduced numbers of monocytes and decreased expression of CD14.

Several studies hypothesized that additional transmembrane receptors must act in concert with LPS-CD14 complex to initiate the signaling process leading to LPS-induced cellular activation. CD14-blocking monoclonal antibodies could only partially inhibit LPS-binding, suggesting the existence of alternative receptors (21, 128, 214, 216). Different signaling molecules must be recruited to the site of ligation, which is combined with CD14 by LPS. LPS is released into the lipid bilayer where it interacts with a complex of receptors, which include Hsp 70, Hsp 90, CXCR4, GDF5 and TLR4 (214).

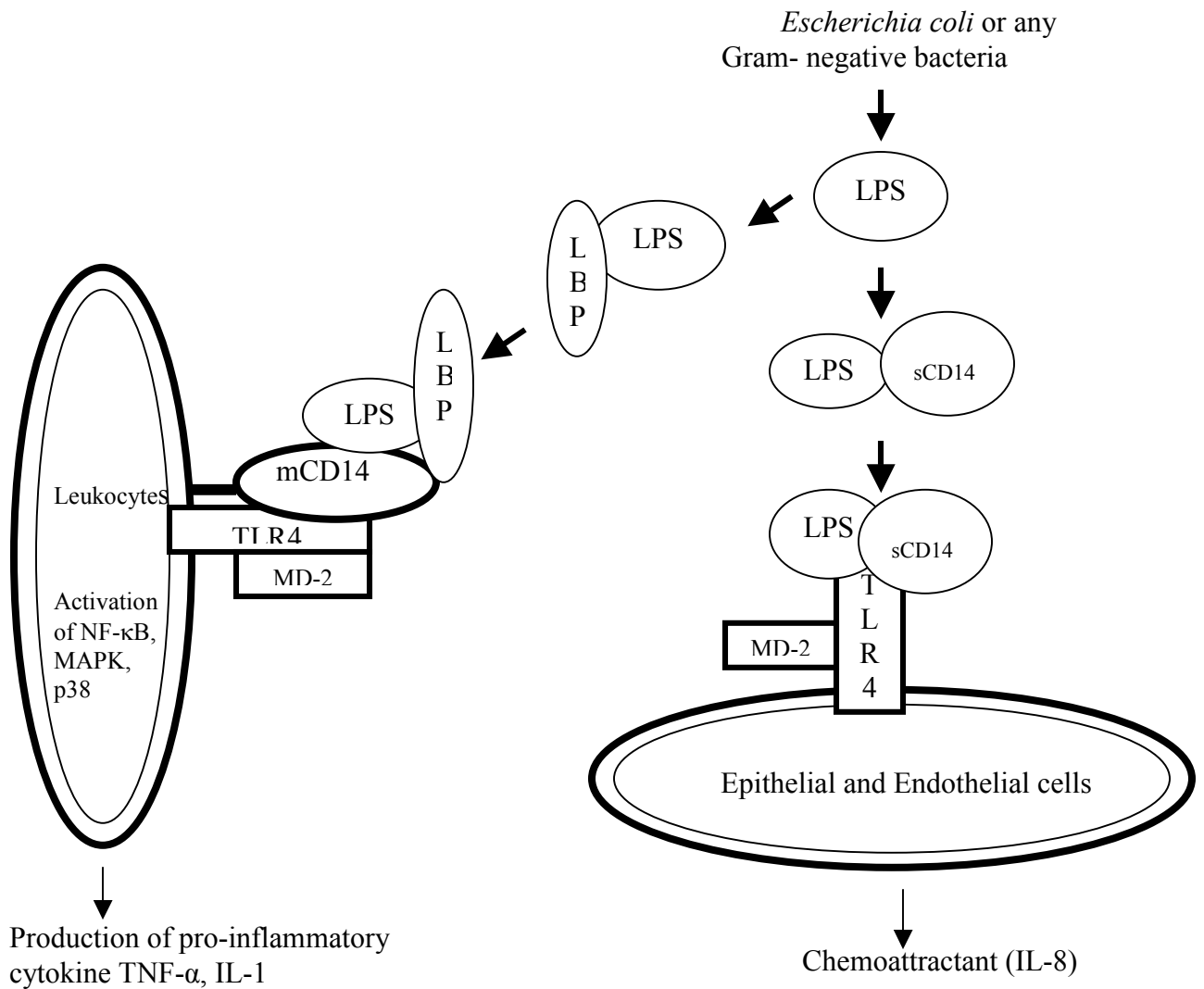

Figure 2. Binding of the LPS-binding protein/LPS complex to mCD14 on monocytes and macrophages causes release of pro-inflammatory cytokines and binding of the sCD14/LPS complex to Toll receptors on endothelial and epithelial cells causes release of chemoattracts.

III. Biological function of CD14

Human monocytes express high levels of CD14 ($\sim 10^5$ receptor/cell) whereas CD14 expression on PMN is much lower ($\sim 3 \times 10^3$ receptors/cell). CD14 expression on tissue macrophages can vary depending upon their origin. sCD14 occurs in normal human plasma at concentrations of 12 $\mu\text{g/mL}$ (111) and in uninfected quarters in cows at concentration of 1-6 $\mu\text{g/mL}$ (14, 16, 117). The cellular source of sCD14 in human milk was shown to be mammary epithelial cells, which secrete in culture a slightly smaller form of sCD14 than the sCD14 released by monocytes (111).

CD14 lacks transmembrane and intracellular domains and thus cannot by itself initiate signal transduction. Nevertheless, CD14-deficient mice are highly resistant to LPS-induced shock. Monocytes derived from CD14-deficient mice are insensitive to LPS as determined by LPS-induced IL-6 production, suggesting essential roles for CD14 in binding to LPS (90). Administration of sCD14 has been demonstrated to inhibit LPS-induced TNF- α production and decrease fatality in LPS-challenged mice (88, 205). Moreover, acquisition of LBP by sCD14 has been shown to transport LPS to high-density lipoprotein and lead to neutralization of LPS in plasma (228). Presumably, sCD14 competes with mCD14 for LPS to prevent activation of CD14-expressing immune cells. Moreover, enriched sCD14 in milk has been reported to act as a B-cell mitogen and play a role in breast feeding-associated benefits, such as reduced gastrointestinal infections in infants (69, 111). Blockade of CD14 with anti-CD14 mAbs in rabbits infected with *E. coli* pneumonia, did not alter TNF- α , IL-8, and the number of leukocytes in plasma and bronchoalveolar lavage fluid. Although deleterious systemic responses were prevented, the dissemination of bacteria was increased by the blockade of CD14 (74). Pretreatment

with anti-CD14 mAbs prevented LPS-induced hypotension and reduced plasma cytokine levels in cynomolgus monkeys and inhibited endotoxin-mediated symptoms and inflammatory response in human (122).

Intramammary injection of recombinant bovine sCD14 (rbos) together with low concentrations of LPS into lactating dairy cows caused recruitment of PMN when compared to either LPS or CD14 (220). Intramammary injection of a high concentration of LPS causes an increase of sCD14 in milk attributed to shedding of mCD14 from recruited PMN, and plays a role in modulating the inflammatory response during coliform mastitis (154). rbosCD14 was able to reduce the severity of intramammary gland infection by *E. coli* in a mouse mastitis model (118) and also reduced the severity of infection in dairy cows after intramammary challenge with *E. coli* (119).

IV. Defense of bovine mammary gland by PMN

1. The characteristic of PMN

Polymorphonuclear neutrophil leukocytes (PMN) form the first line of cellular defense against invading bacteria. PMN play a pivotal role in the defense against invading pathogens. The capability of these cells to react to inflammatory stimuli depends on chemotactic, phagocytic, and intracellular killing processes. In addition, the number of circulating PMN before infection has been demonstrated to be crucial to determine the outcome of diseases such as *E. coli* mastitis (92).

The most prominent characteristic of the PMN is their multilobulated nucleus, which allows the PMN to line up its nuclear lobes in a line, permitting rapid migration between endothelial cells. Bovine PMN contain azurophilic and specific granules in

addition to a third novel granule that is larger, denser, and more numerous than the other two granules. This third class of granules contains a group of highly cationic proteins and is a store of oxygen-independent bactericidal compounds (19).

In the human bone marrow, PMN require 10 to 14 days to mature (10). After maturation, they may be stored for a few additional days. The mature PMN leave the hematopoietic compartment of the bone marrow and enter the vascular sinus by traveling in migration channels through the endothelial cell layer. The PMN circulate in the blood stream briefly (half-life of 8.9 hours) (32) and leave the blood stream by diapedesis between endothelial cells. Then, PMN enter the tissue where they function as phagocytes for 1-2 days. Longevity of human PMN has been shown to be positively influenced by bacterial products such as LPS (116). During inflammatory processes such as *E. coli* mastitis and LPS-induced mastitis, the depletion of the circulating PMN pool (54) causes change in the proportion of the bone marrow progenitors.

2. PMN migration from blood to the mammary gland

PMN are the first cells recruited into the milk following bacteria entry into the gland and represent the predominant cell type. PMN have several receptors on their cell membranes (Figure 3), which serve in the process of directed migration from the blood into the milk compartment, called diapedesis. Rolling attachment of PMN to the endothelium is the first step in the recruitment process and is accomplished by interaction between L-selectin on PMN and its ligand on the endothelial cells (106). Next, the β_2 -integrins (CD11a, CD11b, CD11c, and CD18) are accountable for a strong and sustained attachment, followed by transendothelial PMN migration into the extracellular matrix and

through the mammary gland epithelium. The respective role of the two subunits, namely CD11b and CD18 in the migration process has been studied using an *in vitro* diapedesis model (194).

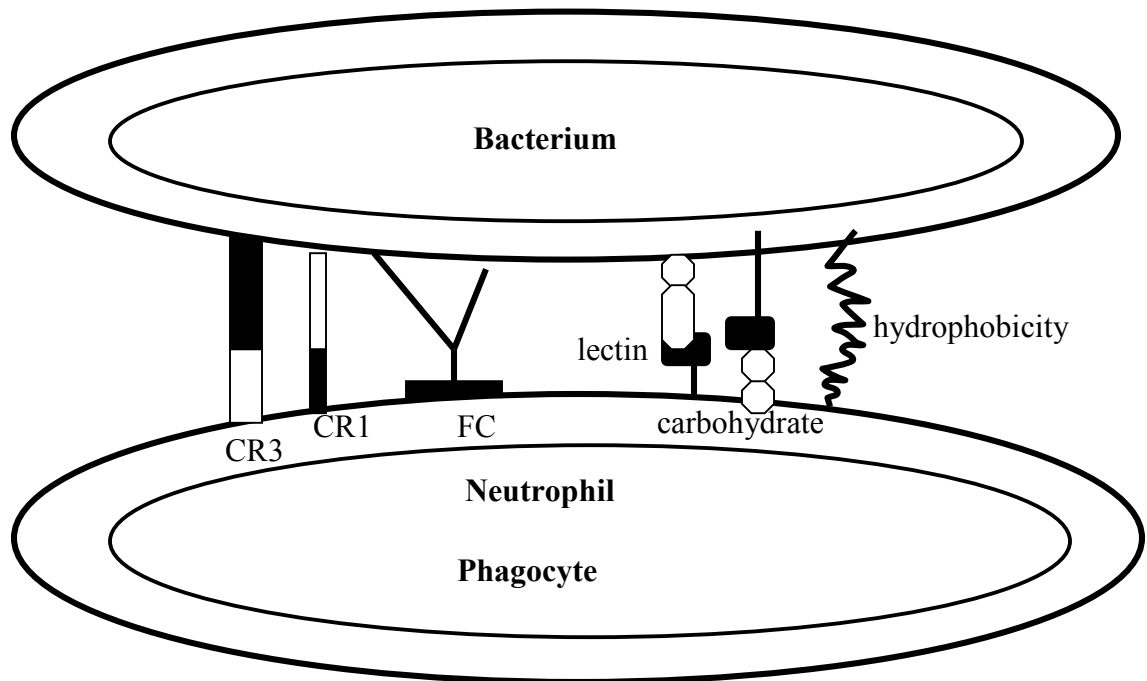

Figure 3. Recognition of bacteria through immunological recognition (CR3, CR1 and FC) and non-immunological recognition mechanisms (lectin, carbohydrate and hydrophobic interaction) on the surface of PMN.

Following diapedesis through the blood-milk barrier, functionality of milk PMN has been shown to be decreased (140). *In vitro*, diapedesis reduced PMN phagocytosis and oxidative burst activity following migration across a mammary epithelial cell layer (196). Migration across the endothelium is almost completely dependent on CD18, and to a lesser extent, on CD11b, whereas the diapedesis across the mammary gland epithelial barrier is more dependent on CD11b. Migration across the collage of the extracellular

matrix was partly dependent on CD18, but completely independent of CD11b (197). At the same time that Mac-1 expression increases, L-selectin is proteolytically shed from the PMN surface (106). CD18 molecule allows PMN to bind tightly to activated endothelium via another endothelial molecule, ICAM (intercellular adhesion molecular)-1. This second adhesive interaction allows PMN to migrate along the endothelial surface and into tissue along a concentration gradient of chemoattractants, the most important being complement components C5a and C3a, LPS, IL-1, IL-2 and IL-8 (40, 43, 77, 209).

3. Phagocytosis and intracellular killing

At the site of infection, activated PMN recognize bacteria through immunological receptors (CR1, CR3, FcR) or non-immunological receptors (lectin, carbohydrate, and hydrophobicity) (Figure 3). Immunological recognition is accomplished by specific antibodies (IgM or IgG₂) on bovine PMN. They recognize bacterium through Fab regions and bind to PMN via Fc-receptors (FcR) on the plasma membrane. The C3b component of complement also opsonizes bacteria and binds to CR1 receptor on PMN.

Next, PMN phagocytose and kill bacteria through their oxygen-dependent and oxygen-independent bactericidal mechanisms (27). Inflammatory cytokines such as IL-1, TNF- α or INF- γ can enhance PMN phagocytosis and/or their bactericidal activity.

Milk PMN are less functional phagocytic and bactericidal than the homologous circulating cells. Milk fat globules and casein are ingested and cause a loss of cytoplasmic granules in PMN. These are associated with a reduction in bactericidal activities and leukocyte rounding that eliminates the pseudopods needed for phagocytic capabilities. In addition to their phagocytic capabilities, PMN are a source of anti-

microbial proteins, such as lactoferrin, bacterenecins, and defensins. After ingestion and release of their chemicals, most of the PMN perish. Next, macrophages migrate through the pores of the capillaries. Damage to tissue is limited by induction of programmed cell death (apoptosis) of PMN, and their bactericidal chemicals are walled off within dying PMN that are then ingested by macrophages to minimize further damage to tissue (155).

PMN recruitment depends on intensity and rapidity according to the pathogens and to the cow. *E. coli* and *S. aureus* are the main pathogens accountable for mastitis. *E. coli* infusion into a healthy gland causes clinical mastitis with severe clinical signs and a loss of milk production. In a few hours, large amounts of the pro-inflammatory cytokines such as IL-1 and IL-8 are detected in milk. PMN recruitment increases rapidly between 3 and 12 h post-challenge following intramammary injection of LPS and *E. coli*, and then returns to normal levels (15, 16, 171, 172, 191, 193). Experimental subclinical *S. aureus* mastitis induces a moderate and a delayed PMN recruitment between 24 and 48 h post-infection of the challenged glands.

V. The role of cytokines in the mammary gland

Experimental coliform mastitis induced by intramammary gland infusion of LPS or *E. coli* has been used for studying the role of PMN in the outcome of intramammary infection, and the subsequent development of inflammation. After intramammary infusion of LPS, cytokines such as TNF- α , IL-1 and influx of PMN are detectable (14).

In vitro studies have shown that mammary epithelial cells may participate in the immunoregulation during mastitis via cytokine production. These cells secrete IL-1 in

response to LPS. IL-1 β also appeared to be an important mediator for the release of IL-8 from mammary epithelial cells (22). TNF- α and IL-1 β were shown to affect tight junctions between the epithelial cells, lowering the transepithelial resistance (176) and allowing exchange of inflammation metabolites and cells between the two blood-milk barrier compartments. Another action of IL-1 and TNF- α is to activate fibroblasts of the mammary gland, with subsequent IL-8 secretion (114). TNF- α up-regulates PMN phagocytosis, adherence, chemotaxis, and release of reactive oxygen species (199).

IL-8 is a PMN-specific chemoattractant and is produced in the response to inflammatory stimuli by a variety of cells (9). IL-8 induces PMN chemotaxis, respiratory burst, degranulation, and increased adherence to endothelial cells (35). IL-8 stimulated the transmigration of PMN through the endo-epithelial barrier in a dose-dependent manner suggesting that the production of IL-8 by mammary endothelial cells at the site of inflammation plays an important role in the recruitment of PMN into the infected gland (120).

In addition to the role in the pathogenesis of mastitis, cytokines initiate an increase in temperature and induction of metabolic changes, and prime or activate PMN. Cytokines can change the rate of bone marrow production and release of PMN. Cytokines also enhance PMN migration to the infection site, and increase PMN phagocytosis and respiratory burst (203).

Cytokines mostly have a pleiotropic effect and an autocrine and a paracrine function. Therefore, undesirable side effects are an important obstacle for application of cytokines in the field. Administration of some bovine cytokines *in vivo* resulted in a

positive effect on immunity (44, 147, 169). Pretreatment of cows with INF- γ would exert a protective effect against a subsequent experimental infection (200).

VI. Transgenic plants

In the past several years, recombinant nucleocapsid proteins have been expressed in *E. coli*, in a baculo and vaccinia virus expression system in silkworms and in mammalian cells (181). Recombinant nucleocapsid proteins expressed in insect cells, bacteria or as chimaeric HBV core particles, can evoke protective immunity in an animal model (231).

Recent studies have shown that proteins expressed in plants are effective tools for production of antigens. Bacterial toxins and various viral proteins have been successfully expressed in plants. These proteins were able to elicit specific humoral and mucosal immune responses when administered intraperitoneally and protected animals against the corresponding bacterial or viral infections (133, 232). The expression of immunogenic viral proteins has been successfully performed in plants and is immunogenic. Plant expression systems have the following advantages over other expression systems. First, the post-translation protein modification takes place in eukaryotic cells. Second, there is no risk of contamination with mammalian viruses or other pathogens, and the production of the antigens based on expression of the proteins is inexpensive and therefore of economical interest. An example of the potential usefulness of transgenic plants for production and delivery of edible vaccines had been demonstrated for the Norwalk virus (133). Successful expression of the Norwalk virus capsid proteins in transgenic tobacco and potato plants and showed good immunogenicity after oral application in mice.

OBJECTIVES

The objectives of the studies were: 1) to produce and characterize a panel of anti-rbosCD14 mAb to be used to reduce the release of inflammatory cytokines from bovine macrophages, and to develop an ELISA for quantitating bovine solubleCD14, 2) to express recombinant bovineCD14 protein in plants and determine biological activity *in vitro* and *in vivo*, 3) to investigate the expression and shedding of CD14 molecules and it's effect on the expression of IL-8 in bovine PMN after LPS stimulation, and 4) to determine the release of inflammatory cytokines from PMN in response to LPS.

Chapter Two: The Production and Characterization of Anti-bovine CD14 Monoclonal Antibodies

ABSTRACT

To characterize further the chemical and biological properties of rboCD14, a panel of ten murine monoclonal antibodies (mAb) reactive with recombinant bovine CD14 (rbo) were produced. A sandwich ELISA, using murine mAb and rabbit polyclonal antibodies reactive with rboCD14 was developed. All the mAbs were reactive by ELISA with baculovirus-derived rboCD14 and they recognized rboCD14 (40 kDa) by Western blot analysis. The mAb also identified by Western blot sCD14 (53 and 58 kDa) in milk and blood and mCD14 (47 kDa) in a lysate of macrophages obtained from involuted bovine mammary gland secretions. Analysis by ELISA of whey samples after intramammary injection of LPS (10 µg) revealed increased sCD14 levels between 8 to 48 h after injection. Flow cytometric analysis showed that the mAb bound to macrophages isolated from involuted mammary gland secretions and mouse macrophages but not to swine or horse monocytes. Addition of anti-rboCD14 mAb to monocytes stimulated with LPS reduced *in vitro* production of TNF-α. The anti-rboCD14 antibodies generated in this study will be useful in studying CD14, an accessory molecule that contributes to host innate recognition of bacterial cell wall components in mammary secretions produced during mastitis.

Introduction

CD14 was first described as a monocyte/macrophage differentiation antigen

that is attached to the cell surface by a GPI anchor (91). mCD14 is a 55 kDa glycoprotein which binds LPS and initiates cell activation. This receptor is abundant on the cell membrane of monocytes and macrophages and is present at a lower density on PMN (6). sCD14 has been detected in bovine milk (110), and in human serum and urine (18, 87, 235). mCD14 is an accessory receptor for LPS that activates monocytes, and is capable of binding low concentrations of LPS that are complexed to serum-derived LBP (227).

sCD14 exists in at least two isoforms which range in size from 48-56 kDa (59). sCD14 found in human serum has been attributed to the shedding of mCD14 from monocytes, macrophages and PMN (59, 100). Studies with human monocytes and monocytic cell lines have shown that mCD14 is released via protease-dependent or independent pathways. Some isoforms originate from shedding of mCD14, while others are secreted after synthesis by monocytes and macrophages (25). sCD14 present in the serum/plasma and urine of nephritic patients mediates activation of cells not bearing mCD14 including epithelial cells and endothelial cells (7, 75). Macrophages are the predominant cell type in milk from uninfected bovine mammary glands whereas PMN predominant in mastitic milk. Bovine macrophages and PMN in milk express mCD14 on their cell surface (154) and are potential sources of sCD14.

LBP promotes rapid binding of LPS and forms aggregates that bind to mCD14 (227). mCD14 is important for conferring sensitive cellular responses to LPS. LPS induction of cytokine release, particularly TNF- α and IL-1, is probably the central most important event in initiating the acute-phase response to infection (14). LPS stimulates the cells by ligating specific membrane receptors like CD14 that are important for cytokine release.

Anti-CD14 mAb blocks release of TNF- α from macrophages (52, 88) and protects primates from endotoxin shock (55, 240).

Coliform mastitis, which is caused by Gram-negative bacteria, is the most prevalent form of clinical mastitis, with infection by *E. coli* being the most frequent. Approximately 80% of all intramammary infections by coliform bacteria will result in clinical mastitis, and about 25% of the cows will develop acute clinical symptoms (60, 61). Coliforms are present in the cow's environment and they cannot be eradicated on a practical basis. Conventional herd management practices such as post-milking teat dipping, and dry cow antibiotic therapy have been unable to reduce the incidence of new intramammary infections by coliforms. Pre-dipping has been shown to decrease environment mastitis due to *Streptococci* and coliforms. Even in well-managed herds coliform mastitis continues to exist as an animal health problem. In addition, antibiotic treatment, extensive fluid supplementation and metabolic support are not effective in relieving symptoms associated with clinical coliform mastitis (153). Anti-bovine CD14 mAb may provide a means of reducing clinical symptoms during acute coliform mastitis by blocking the binding of LPS to mCD14 on monocytes and macrophages, thus down-regulating release of inflammatory mediators like TNF- α and IL-1. The objectives of this study were to: 1) produce anti-rbosCD14 mAb that could be used to reduce release of inflammatory cytokines from bovine macrophages, and 2) develop an ELISA for quantitating bovine sCD14.

MATERIALS AND METHODS

Production of rbosCD14

The rbosCD14 was produced in a baculovirus expression system as previously described (227). Briefly, rbosCD14, with a deletion of 14 amino acids at the C-terminal end, was generated by insect sf/9 cells infected with recombinant virus containing the gene. The rbosCD14 was purified from culture supernatant using Ni-NTA superflow agarose beads (Qiagen, Valencia, CA, USA) and FPLC system (Amersham Pharmacia, Uppsala, Sweden) with a typical yield of 4-6 mg/L of culture supernatant. Functional analysis of the rbosCD14 showed that it reduced mortality in mice from endotoxin shock and reduced severity of intramammary infection in mice and cows after experimental challenge with *E. coli* (118, 119).

Hybridoma production and mAb purification

Four female BALB/c mice (National Cancer Center, Fredrick, MD, USA) were immunized intraperitoneally biweekly with 50 µg of rbosCD14 emulsified in Freund's adjuvant (Sigma, St. Louis, MO, USA). Six weeks after the second injection and 3 days prior to fusion, mice were boosted by intravenous injection of 25 µg of rbosCD14 in 0.5 mL of 0.01 M phosphate buffered 0.85% saline, pH 7.4 (PBS). Mice producing high serum antibody titers to rbosCD14 were selected by ELISA, and their spleen lymphocytes were fused with mouse myeloma SP 2/0 cells (ATCC, Rockville, MD, USA). Hybridomas were selected in medium supplemented with hypoxanthine, aminopterin, and thymidine (Sigma), and supernatants screened by ELISA (see below). Hybridomas secreting rbosCD14 antibodies were cloned by limiting dilution using mouse thymus feeder cells. Ascites were produced in female BALB/c mice following intraperitoneal injection with 0.5 mL of 2, 6, 14, 20-tetramethypentadecane (Sigma).

Purification of monoclonal antibodies

Ascites were centrifuged at 500g for 20 min. The top lipid layer was discarded and ascites were filtered through glass wool. Three mL of PBS were added to the ascites. Ascites were centrifuged for 30 min at 20,000g at 4°C. Supernatant was filtered through 0.45 µm syringe filter and diluted up to 50 mL with PBS. Ascites were purified using Hi TrapTM proteinG column (Amersham Pharmacia Biotech, Uppsala, Sweden) with FPLC (Pharmacia Biotech, NJ, USA).

Polyclonal Antibody Production

The immunization protocol is described in detail by Fretterer and Barfield (68). Briefly, a New Zealand white female rabbit, 4-5 pounds and specific pathogen-free, was purchased from Covance Research Products (Denver, PA, USA). The ImmuMax SR adjuvant system, an immunostimulatory biomolecule, surfactant and oil (Zonagen, Inc., The Woodlands, TX, USA), was used to form an emulsion containing 15 µg of rboCD14. The mixture of gel, rboCD14 and ImmuMax SR chitosan was brought to pH 7.0 and emulsified with the surfactant and oil immediately before being injected subcutaneously into the scapular arch of the rabbit. Total volume of the injection was 1.0 mL and was spread over 3-4 injection sites. On day 30 post-immunization, this procedure was repeated. Before immunization, rabbits were bled from the central auricular artery to obtain baseline control sera. At 37 days post-immunization, a second blood sample was obtained to determine positive antibody response and titer.

Isotyping of mAb

A mouse hybridoma isotyping ELISA kit (Biomedica, Foster City, CA, USA) was used to isotype the mAb. Using 96-well microtiter plates, 50 μ L of antigen solution was added to each well and incubated for 3 h at 37°C. The plates were washed once with PBS, followed by addition of 200 μ L of 1% bovine serum albumin (BSA) blocking solution to each well and incubated for 1 h at 37°C. Hybridoma supernatant (100 μ L) was added to each well and 50 μ L of class-and subclass specific anti-mouse antibodies was added to the plates and incubated for 30 min at 37°C. After washing the plates 3 x with PBS, 50 μ L of rabbit anti-goat IgG conjugated to horseradish peroxidase (Bio-Rad) was added to each well and incubated for 30 min at 37°C. After washing the plate 3 x with PBS, 100 μ L of 3, 3', 5, 5'-tetramethylbenzidine (TMB) chromogen/substrate solution (Sigma) was added to each well. The reaction was stopped by adding 50 μ L of 2 N sulfuric acid, yielding a yellow color. Absorbance was measured using a microtiter plate reader (Bio-Tek Instruments, Inc., Winooski, VT, USA) at a wavelength of 450 nm.

Screening for production of anti-rbosCD14

Flat bottom 96-well microtiter plates (Dyrex Technologies Inc., Chantilly, VA, USA) were coated with 100 μ L of rbosCD14 (10 μ g/mL in 0.1 M carbonated-bicarbonate buffer pH 9.6) and incubated at 4°C for 16 h. The plates were washed 3 x with PBS containing 0.05% (v/v) Tween 20 (PBS-T). Each well was blocked with 200 μ L of PBS containing 1% (w/v) BSA (Sigma) for 1 h at room temperature and washed 3 x with PBS-T. Hybridoma supernatants (100 μ L) were added and incubated for one hour at room temperature, and washed 3 x with PBS-T. One-hundred μ L of HRP-conjugated goat anti-mouse IgG (H+L; Sigma) diluted 1:2000 in PBS-0.1% BSA was added, and plates

incubated for 1 h at room temperature. The plates were washed 3 x with PBS and then 100 μ L of 0.01% (w/v) TMB in 0.05 M phosphate-citrate buffer, pH 5.0 was added and incubated at room temperature for 15 min. The reaction was stopped with 50 μ L of 2 N sulfuric acid. Color change was measured by an automated microtiter plate reader (Bio-Tek Instruments) at a wavelength of 405 nm.

Preparation of milk whey and blood plasma

Milk was obtained from five cows at intervals over a 72 h period after intramammary injection of 10 μ g of LPS (*E. coli* 0111:B4, Sigma). LPS (10 μ g) was dissolved in 10 mL of 0.85 % saline and sterile filtered through a 0.22 μ m cellulose acetate filter (Corning Incorporated, Corning, NY, USA). The right or left front mammary quarters were infused with either 10 mL of saline alone or 10 μ g of LPS.

For the preparation of whey, milk samples were centrifuged at 44,000 x g at 4°C for 30 min, and the fat layer was removed with a spatula. The skimmed milk was centrifuged again for 30 min as above, and the translucent supernatant collected and stored at -70°C in aliquotes. Blood samples were obtained from the tail vein and collected in glass tubes containing K₂EDTA (Becton-Dickinson Corp, Franklin Lakes, NJ, USA), centrifuged at 1,500 x g for 15 min, and the clear plasma supernatant was collected and stored at -70°C in aliquots.

Sandwich ELISA for sCD14 in cow milk after challenge with LPS

A sandwich ELISA was used to quantify sCD14 levels in milk whey. Flat-bottom 96-well plates were coated with 5 μ g/mL of mouse anti-rbos CD14 mAb M1-54-2

diluted in 0.05 M sodium carbonate, pH 9.6 at 4 °C. This mAb was selected because it gave an intensely stained band when used in the Western blot (Table I). The plates were washed 4 x with 0.05% Tween 20 diluted in 50 mM Tris buffered saline (TBS), pH 8.0, and subsequently blocked with 2% fish skin gelatin (Sigma) for 1 h at room temperature. Plates were washed and 100 µL of undiluted whey samples were added to each well. Rabbit anti-bovine CD14 polyclonal antibody was diluted 1:2000 in TBS buffer containing 0.2% gelatin, and 100 µL was added to each well and subsequently washed as above. One-hundred µL of HRP-conjugated goat anti-rabbit IgG (H+L; Promega) diluted in PBS containing 0.2% gelatin (1:5000) was added to each well. Plates were incubated for 1 h at room temperature, washed as above, and 100 µL of TMB substrate solution added to each well. The reaction was stopped by the addition of 50 µL of 2 N H₂SO₄ and the absorbance read at 450 nm on a microplate reader (Bio-Tek Instruments, Inc).

Isolation of macrophages and monocytes and cultivation *in vitro*

Bovine mammary gland macrophages were obtained by daily infusion of 50 mL of sterile isotonic saline solution into the involuted mammary quarter of 3 normal adult cows for five consecutive days (49). To avoid infection of the gland, the teat orifice was washed with 70% ethanol, and a sterile teat cannula was used to infuse the saline. Following gentle massage, the suspension was milked out into a 50 mL plastic conical centrifuge tube that contained 25 mL of ice cold PBS. The samples were kept on ice and transported to the laboratory. The suspension was centrifuged at 250 x g for 15 min at 4°C. The cell pellet was suspended in 10 mL of PBS. Duplicate films were made on glass slides and stained with Wright stain using an automatic slide stainer. Leukocyte

differential counts of 200 cells were performed on each slide at a magnification of 1250 using the battlement procedure (99). Because large lymphocytes in cows may resemble macrophages/monocytes (84) only cells with characteristic amoeboid nucleus and vacuolated moderate blue cytoplasm with or without fine azuorphilic granules were counted as macrophages (99). On average, 65% of the cells were macrophages with 98% viability as determined with Trypan blue.

Cross-reactivity of the anti-rbosCD14 mAb was performed using mouse macrophages, and porcine and equine monocytes. For the preparation of mouse macrophages, primary cultures of mouse fibroblast/macrophages (MEF/Mac) were initiated by explant culture of day-16 to -18 gestation fetal mice after removal of viscera (73). Finely minced fetal mouse tissue was plated in T25 flasks in 2 mL of Dulbecco's modified Eagle's medium with 4.5 g/L glucose (high glucose) supplemented with 10% fetal bovine serum, 2 mM glutamine, and 50 U/mL penicillin/streptomycin (10% DMEM/H). After attachment and initial outgrowth (-96 h), 4 mL of additional 10% DMEM/H was added to each primary culture flask. Secondary cultures were produced by washing the primary cultures twice with PBS and once with trypsin-EDTA solution. The released cells were resuspended in 10% DMEM/H and replated in T25 flasks at a 1:3 split ratio. Secondary MEF/Mac cultures were routinely passaged at a 1:4 split ratio at 7-day intervals until senescence occurred at approximately passage 12. A culture medium regimen of 3 days on 10% DMEM/H followed by 4 days on 10% DMEM/low glucose was maintained over each passage to foster maximum growth of the macrophages. By passage 3-4 approximately 70% of the cells in the cultures were macrophages.

Monocytes isolated from porcine blood were kindly provided by Dr. Joan Lunney, Animal Parasitic Diseases Laboratory, USDA-ARS, Beltsville, MD. Monocytes isolated from equine blood were kindly provided by Dr. Martin Furr, Department of Veterinary Medicine, Virginia Tech, Blacksburg, VA, USA.

Immunoblot analysis

The rboCD14 was resuspended in SDS-PAGE sample buffer, heated and resolved on a 4-12% Bis-Tris gel (Invitrogen). Separated proteins were electrophoretically transferred to Immobilon-P membrane (Millipore, Bedford, MA, USA) using the Mini-Protean II transfer chamber (Bio-rad). The membrane was blocked overnight at 4°C in PBS containing 1% BSA, washed 2 x with PBS-T and sequentially incubated at room temperature with supernatant of rboCD14 mAb for 1 h and goat anti-mouse IgG peroxidase antibody (1: 2000 in PBS-1% BSA) for 30 min. The membrane was washed 5 times with PBS-T, 5 times with distilled water and developed using Sigma Fast DAB peroxidase substrate (Sigma).

Flow cytometric analysis

One-million cells were reacted with anti-rboCD14 mAb (1:100), and incubated at 4°C for 30 min. The cells were washed 3 x with PBS. Fluorescein isothiocyanate (FITC)-labeled affinity-purified antibody to mouse IgG +IgM (H+L) (KPL, Gaithersburg, MD, USA) was added at a 1:100 dilution in PBS to cells reacted with the mAb and control cells that were not reacted with mAb. After 30 min of incubation at 4°C, the wells were washed 3 x with PBS and resuspended in 200 µL PBS. Flow

cytometric analysis was performed using a Coulter Epics Profile I-Argon laser flow cytometer (Coulter Electronics Inc, Hialeah, FL, USA). The laser was set at 488 nm wavelength, 7.0 to 7.5 A current and 15 mW power; it was aligned by use of fluorospheres (Immuno-Check, Epics alignment fluorospheres, Epics Division, Coulter Corp, Hialeah, FL, USA). Gains for forward-angle light scatter were set at 10, and logarithmic transformations were used for side (90°) light scatter and for green fluorescence. Locations of the cell populations in dot plots had been determined previously on the basis of analyses of pure populations of leukocytes (154). A bitmap (electronically defined observation area) was drawn around the large mononuclear cell population that contained both large lymphocytes and macrophages, and fibroblasts for the mouse macrophage preparation. Percentage of cells fluorescing (%F) and the level of expression of CD14 molecules (log mean fluorescent channel [LMFC]) were recorded by measuring the green fluorescence associated with the gated mononuclear cell population.

Use of anti-rbosCD14 mAb to block *in vitro* release of TNF- α from cultured monocytes

Blood from cows was collected from the median caudal vein in 15 mL evacuated tubes containing 1.5 mL of acid citrate dextrose (40% trisodium citrate, 14.5% citric acid, 45.5% dextrose). For the isolation of monocytes, the blood was centrifuged at 900 x g for 30 min at 4°C with the brake disengaged. The buffy coat layer was removed, and transferred into a sterile 40 mL glass vial containing 20 mL Hanks' balanced salt solution (HBSS, Invitrogen Corp., Grand Island, N.Y, USA). Ficoll-paque (Amersham Pharmacia, Biotech, AB, Uppsala, Sweden) (12.5 mL) was layered over the HBSS in a

50 mL centrifuge tube. After centrifuging for 30 min at 450 x g, the band containing the mononuclear cell was removed and transferred into a 50 mL centrifuge tube, resuspended in 45 mL of HBSS and centrifuged at 180 x g for 10 min at 5°C. Contaminating red blood cells were removed by resuspending the cells in 5 mL HBSS, 10 mL of double distilled water was added, gently mixed for 18 seconds and then 10 mL of 2 x minimum essential medium Eagle (Sigma) was added to restore isotensity. The cell suspension was centrifuged 180 x g for 10 min at 5 °C and resuspended in 10 mL HBSS.

A 1 mL aliquot of the cell suspension containing 10^5 monocytes was added to 24 well tissue culture plates and incubated for 1 h at 37°C. After incubation, the non - adherent cells were removed and then 1 mL of medium-RPMI 1630 (Gibco Brl, Life Technologies, Grand Island, N.Y, USA) containing penicillin (100 U/mL), streptomycin (50 µg/mL) (Sigma, Louis, MO, USA) and 10% heat-inactivated FBS. Monocytes were preincubated with 10 µg of anti-rbosCD14 mAb (M1-54-1) or media for 20 min at 4 °C. Next, LPS (0.1, 0.01, and 0.001 ng/mL) was added to the wells and incubated for 24 h at 37 °C in 5 % CO₂. The media from each well was collected and centrifuged at 9,300 x g for 30 min. The supernatant was collected and assayed for TNF-α as previously described (154).

Statistical Methods

A t-test or analysis of variance with the Tukey post hoc comparison test was used to compare the mean responses between a single experimental group and its control or among multiple experimental groups, respectively. All statistical analyses were

performed using GraphPad InStat version 3.05 for Windows (GraphPadSoftware Inc., San Diego, CA, USA). A *P*-value of 0.05 or less was considered significant.

RESULTS

Production of anti-rbosCD14 mAb

Following immunization with the rbosCD14, 10 murine hybridomas secreting mAb reactive with the immunogen were identified. Table I summarizes the immunoglobulins isotypes, ELISA and Western blot reactive assay results. All antibodies were reactive with rbosCD14, but not with BSA, cell culture media, or with non-immunized mouse serum that was used as negative controls. Representative ELISA results using the strongly reactive mAb M 1-6-6 are illustrated in Figure 4.

Intramammary challenge with LPS increases concentration of sCD14 in milk.

To determine whether the mAb could be used to detect and quantify sCD14 in whey a sandwich ELISA was used to quantitate sCD14 in milk (Figure 5). Mammary gland quarters receiving saline alone showed no change in sCD14 levels throughout the study. In contrast, significant ($P < 0.05$) increases in sCD14 were evident within 8 h of LPS infusion and this increase persisted for an additional 40 h. Maximal levels of sCD14 were observed 24 h after LPS challenge.

Western blotting

By Western blotting analysis, all mAb reacted with a 40 kDa protein for rbosCD14 (Figure 6). The mAb also recognized 53 kDa and 58 kDa sCD14 in bovine

milk and bovine plasma (Figure 6). Four additional mAb (M 5-29-3, M 4-2-3, M 3-3-8, M1-6-6) also strongly recognized a 47 kDa mCD14 protein and a possible accessory 24 kDa protein from a lysate of mammary macrophages (Figure 7). However, two monoclonal antibodies (M 2-7-2, M 1-54-2) strongly reacted with the 40 kDa recombinant protein but not to the macrophage lysate. Additionally, four monoclonal antibodies (M 1-34-9, M 1-52-8, M 3-9-1) showed only one 47 kDa band from the macrophage lysate (data not shown).

The binding of mAb to macrophages and cross-reactivity studies

To study the binding of anti-rbosCD14 mAb to mCD14 on macrophages from mammary glands of healthy cows and to perform cross-reactivity studies, flow cytometry was performed using mouse anti-rbosCD14 mAb generated in this study. The reactions of the ten anti-rbosCD14 mAbs (diluted 1:1000) with macrophages isolated from involuted bovine mammary glands as measured by flow cytometry is shown (Table II). After correcting for autofluorescence of the cell preparation (9.9%), the percentage of cells recognized by the ten mAbs ranged from 58.0 to 66.9%. LMFC ranged from 3.0 to 4.1. No correction for autofluorescence was applied because with a low percentage of the cells fluorescing, the LMFC will be widely scattered along the X axis and will cause inflated values for LMFC. mAb M1-6-6 and M3-3-8 showed the highest binding to macrophages from involuted mammary secretions and bound to 67% (LMFC 16) of cells in a mouse macrophage cell culture. In contrast, these mAb did not bind to blood monocytes isolated from swine and horse blood (Data not shown).

TNF- α release from monocytes incubated with anti-rbosCD14 mAb and exposed to LPS

Inhibitory effect of mouse anti-rbosCD14 mAb (M1-54-1) on the LPS induced production of TNF- α by adherent monocytes during 24 h of incubation was dose dependent (Figure 8). The inhibition of TNF- α by anti-rbosCD14 mAb was obtained at all concentrations of LPS (1 to 100 ng/mL, $P < 0.05$). The greatest inhibition (61%) of TNF- α production was achieved when 100 ng/mL of LPS was used to stimulate the monocytes. With 1 and 10 ng of LPS/mL less inhibition (37 and 54 %) was observed. The anti-rbosCD14 mAb did not affect the production of TNF- α by unstimulated monocytes (data not shown).

DISCUSSION

Several of the mouse anti-rbosCD14 mAb developed in this study showed strong reactivity with bovine mammary macrophages by flow cytometry and to sCD14 in milk whey when used in an ELISA. Using the anti-rbosCD14 mAb, we demonstrated that the relative molecular mass for mCD14 from the bovine macrophage lysate was 47 kDa (Figure 7). Bovine mCD14 is shorter than human mCD14, which has a molecular mass of 50-58 kDa. Also, the ten murine anti-rbosCD14 mAbs developed in this study show different recognition patterns to macrophages by also recognizing a 24 kDa band. This band may be a mCD14 precursor or a truncated mCD14 degradation product. We also demonstrated that sCD14 in bovine milk and blood exists in two forms of 53 and 58 kDa (Figure 6). It was previously shown that mCD14 on monocyte and macrophage exists in two soluble forms in normal human plasma (59). These two sCD14, which are referred to

as sCD14 α (low Mr) and sCD14 β (high Mr), can also be synthesized and released into plasma by normal human monocytes. Different molecular mass forms of sCD14 are present in human serum depending on its origin (25, 59, 112). The lower molecular mass forms are derived from the proteolytic cleavage of monocyte mCD14, and, therefore, have a truncated C-terminus without the GPI-anchor. These same cells also produce a high molecular mass CD14 receptor lacking the GPI-anchor, which is directly exocytosed. Varying degrees of glycosylation also contribute to the heterogeneity of the sCD14 molecule (202).

Using the anti-rbosCD14 mAb and ELISA that was developed in this study, we were able to demonstrate an increase in sCD14 in milk whey after intramammary injection of LPS. The increase paralleled previously reported increases in sCD14 in milk whey in response to LPS using commercially available mAb (14). In that study, it was also shown that increases in milk PMN counts preceded the increase in sCD14. This suggests that PMN may be the source of the sCD14, because it was previously shown that PMN express sCD14 on their cell surface (154).

Effective approaches for the treatment of Gram-negative infections lag behind the substantive advances made in understanding host mechanisms involved in response to sepsis. This makes the relationship between the timing of delivery and the efficacy of potential therapeutics for septic shock a critical issue. In the present study, LPS induced release of TNF- α by isolated monocytes was reduced by anti-rbosCD14 mAb. The inhibition of TNF- α secretion by anti-rbosCD14 mAb can be explained by reduced activation of monocytes during interaction of these stimuli with CD14. The inhibitory effect of anti-rbosCD14 mAb on the secretion of TNF- α by LPS stimulated monocytes

can be due to impaired binding of these stimuli to CD14 and/or decreased activation of monocytes via CD14. The region of CD14 that recognizes and binds LPS has been determined (204, 220, 239), and most likely Gram-negative bacteria bind via LPS at their surface to the same site of CD14. Intact Gram-negative bacteria can bind to m- and sCD14 in the presence of serum (220). That indicates that LPS incorporated into the membrane of Gram-negative bacteria can interact with CD14. Intact Gram-negative or Gram-positive bacteria are more powerful stimuli for cytokine production by monocytes than are shed bacterial components (145). Thus, it is conceivable that exudates from macrophage containing phagocytosed bacteria include cytokines that are involved in the initial clinical manifestations (145). It can be anticipated that *in vivo*, blocking of the CD14 receptor will inhibit the inflammatory response to LPS and may be beneficial in severe sepsis. Indeed, anti-CD14 mAb administered after injection of LPS, protected rabbits from death and renal and pulmonary injury, and prevented hypotension and leukopenia (187). In cynomolgus monkeys, pretreatment with anti-CD14 mAbs derived from the same murine component 28C5 as IC14 prevented LPS induced hypotension and reduced plasma cytokine levels (55). These results support the concept that anti-CD14 treatment provides a new therapeutic window for the prevention of pathophysiologic changes that result from exposure to LPS during septic shock.

The anti-rbosCD14 mAb developed in the current study may be useful in reducing clinical symptoms associated with augmented release of TNF- α by monocytes. The mAb will afford the opportunity to relate various functional characteristics to specific groups of cells, which will lead to a better understanding of the interrelationship between CD14 and LPS.

Table I. Immunoglobulin isotype and results from ELISA and Western blot analysis for the ten mAb developed in this study.

Mabs	Isotype	ELISA		Western blot	
		bosCD14	Control	bosCD14	Control
M1-54-1	IgG1, _K	+++	-	+++	-
M1-34-2	IgG2b, _K	+++	-	++	-
M1-6-6	IgG2b, _K	+++	-	+++	-
M3-3-8	IgM, _K	+++	-	+	-
M1-34-9	IgG2b, _K	+++	-	++	-
M2-7-7	IgG3, _K	+++	-	+++	-
M1-54-2	IgG1, _K	+++	-	+++	-
M4-2-3	IgM, _K	+++	-	+++	-
M5-29-3	IgM, _K	+++	-	+++	-
M5-2-8	IgM, _K	+++	-	+	-

+ = weak reactivity, ++ = moderate reactivity, +++ = strong reactivity

Table II. Reactivity of murine anti-rbosCD14 mAb with macrophages isolated from involuted bovine mammary glands (n = 2 cows) as measured by flow cytometry. Specific mAb binding was detected by FITC-labeled goat-anti-mouse IgG and IgM.

mAb	Percentage cells fluorescing^{a,b}	Log mean fluorescent channel^{b,c}
M1-54-1	67.4 ± 3.8	3.2 ± 0.7
M1-34-2	68.8 ± 2.1	3.0 ± 0.5
M1-6-6	74.9 ± 8.7	3.7 ± 0.4
M3-3-8	76.3 ± 2.5	4.1 ± 0.5
M1-34-9	68.0 ± 4.3	3.2 ± 0.7
M2-7-7	71.8 ± 4.4	3.4 ± 0.8
M1-54-2	71.6 ± 3.1	3.3 ± 0.6
M4-2-3	73.0 ± 8.0	3.4 ± 0.6
M5-29-3	72.1 ± 6.5	3.5 ± 0.8
M5-2-8	68.9 ± 7.9	3.3 ± 0.8
Control ^d	9.4 ± 3.8	1.9 ± 0.1

^aThe cell preparation averaged 65% macrophages

^bMean ± Standard error of the mean

^cA measure of CD14 receptor density of the cell surface

^dIsolated cell preparation incubated with FITC-labeled goat anti-mouse IgG and IgM only.

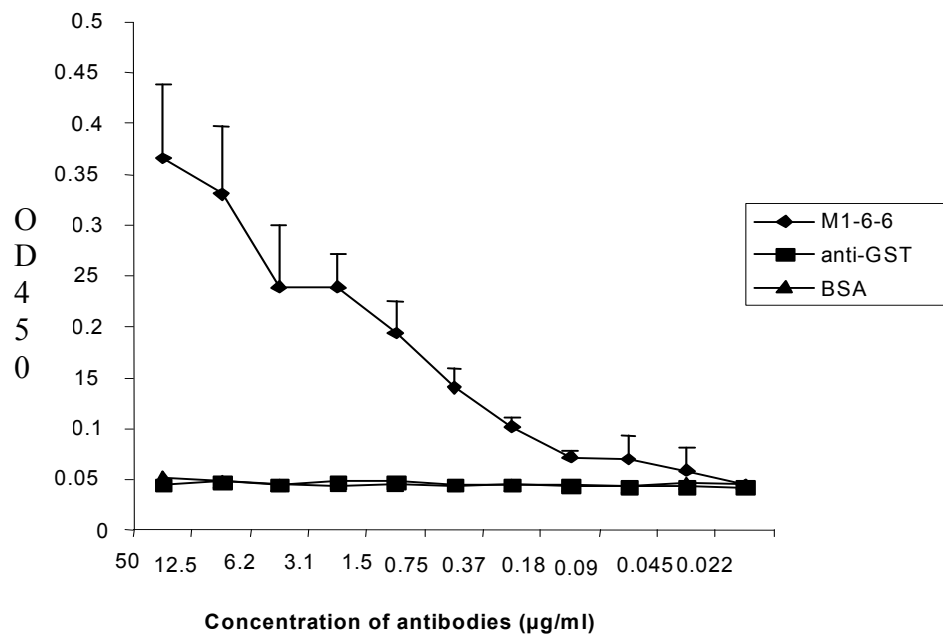

Figure 4. Representative ELISA results for the anti-rbosCD14 mAb developed in this study for mAb M1-6-6. Controls include bovine serum albumin (BSA) and glutathione-S-transferase (anti-GST) a polyclonal antibody purified from goat sera (Pharmacia).

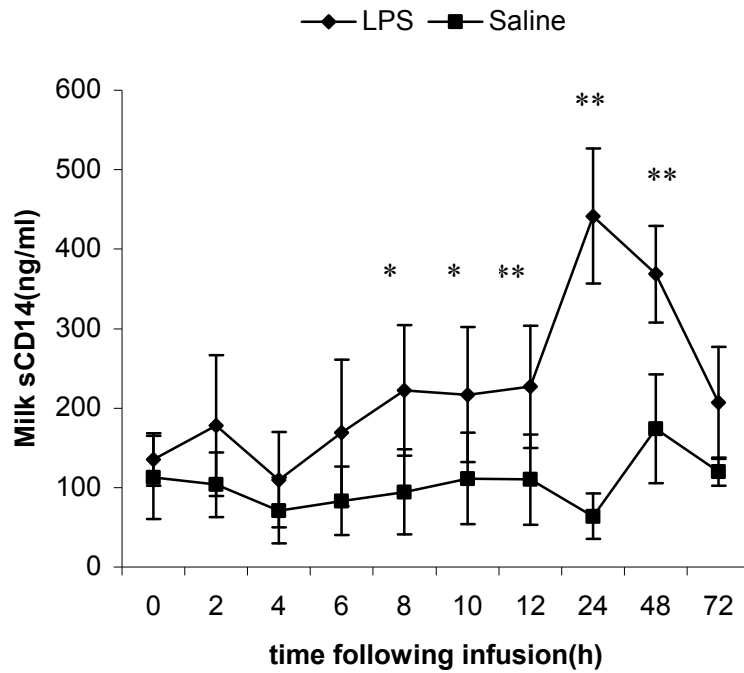

Figure 5. A sandwich ELISA was used to quantify sCD14 in milk obtained from mammary quarters of cows that received either saline or LPS (10 µg). Mean (± SE). N=5. Significantly increased compared to saline control at the same time point (* P < 0.05, ** P < 0.01)

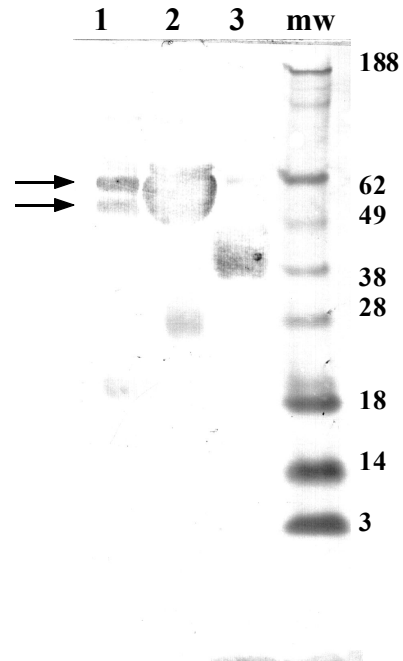

Figure 6. Representative Western blotting analysis using mAb M5-29-3 showing identification of a 53 and 58 kDa proteins, indicated by arrows, in milk whey (lane 1) in blood plasma (lane 2) and a 40 kDa protein in rboCD14 (lane 3). Milk whey was prepared 8 h after intramammary injection of 100 μ g of LPS.

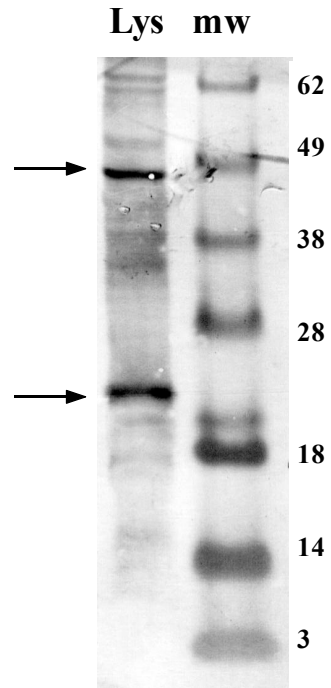

Figure 7. Representative Western blotting analysis of a macrophage lysate (Lys) using anti-rbosCD14 mAb M1-6-6 showing identification of 47 and 24 kDa proteins (arrows).

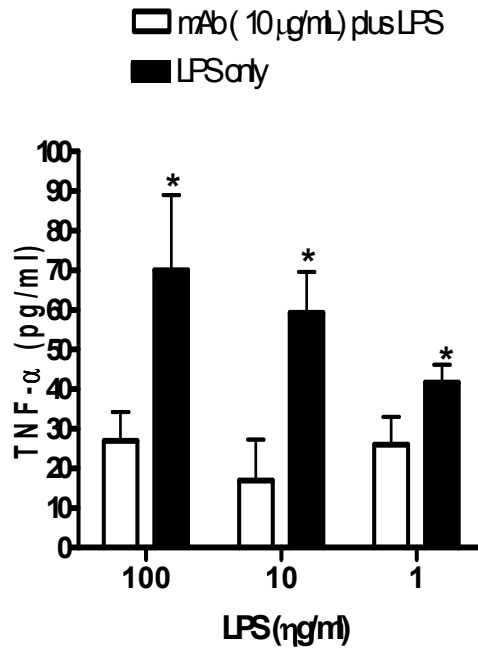

Figure 8. Anti-rbosCD14 mAb (10 μg/mL) inhibits TNF-α response of monocytes after stimulation with LPS. Monocytes were preincubated with anti-rbosCD14 for 1 h before addition of LPS. Data are presented as the mean ± standard error of the mean (* = $P < 0.05$)

Chapter Three: Expression of a Functional Bovine CD14 Receptor in Plants

ABSTRACT

The CD14 antigen is a high affinity receptor for the complex of bacterial LPS and LBP in animals. Binding of the sCD14 to LPS, found in the outer membrane of *E. coli* and other Gram-negative bacteria, enhances host innate immune responses and reduces the severity of mastitis. sCD14 also facilitates clearance and neutralization of LPS, thus, protecting against an excessive immune response to LPS and the development of endotoxic shock. In this study, sCD14 protein was expressed in plants with the aim of developing a low cost, high yield system to produce a potential animal therapeutic for mastitis treatment. A truncated form of sCD14, carrying a histidine residue affinity tag for ease of purification, was incorporated into *Potato virus X* for transient expression in *Nicotiana benthamiana*. Western blots probed with CD14-specific antibodies demonstrated that crude plant extracts and affinity-purified samples contained immunoreactive recombinant protein of predicted molecular mass. Biological activity of the plant-derived recombinant sCD14 (prbosCD14) was demonstrated *in vitro* by LPS-induced apoptosis and IL-8 production in bovine endothelial cells, and *in vivo* by enhancement of LPS-induced neutrophil recruitment. Finally, in *E. coli* infected mammary glands subsequently infused with prbosCD14 or saline, lower numbers of viable bacteria were recovered from prbosCD14 infused glands, thus, demonstrating therapeutic efficacy in the setting of coliform mastitis. This is the first report of the functional activity of a recombinant animal receptor protein made in plants and the use of a plant-derived protein as a potential animal therapeutic for bacterial infections.

INTRODUCTION

Macrophages express surface receptors for many bacterial components, including LPS. LPS, also known as endotoxin, is a complex glycolipid in the outer membrane of all Gram-negative bacteria. LPS is a highly pro-inflammatory molecule, which, in picogram quantities can induce mammalian cells to secrete cytokines, which in turn can induce fever, dysregulated coagulation, and systemic vascular collapse (11).

CD14 exists in mCD14 as a mediator of LPS signaling and also in sCD14 where it binds LPS directly and enhances LPS responses in cells that lack mCD14 (163). LPS interacts with mCD14 on macrophages after formation of a complex with LBP, the latter of which functions to transfer LPS monomers to mCD14. mCD14-LPS complexes then activate TLR4, a transmembrane receptor involved in the activation of intracellular LPS signaling pathway, that, via its cytoplasmic domain, transduces the signal downstream. Activation of one such signaling pathway leads to the release and translocation of NF- κ B, a transcription factor, which up regulates expression of pro-inflammatory cytokines.

Mastitis has a significant economic impact. Discarded milk, increased culling and, in some cases, death, further increase the expense. Estimates of total cost have ranged from \$200 to \$300 per cow per year. The total cost to the dairy industry in the United States is estimated to be approximately \$ 2 billion, which is equivalent to 11% of the total farm milk sales(145). It was previously demonstrated that intramammary injection of insect cell-derived recombinant bovine sCD14 (rbosCD14) is able to reduce the severity of inflammatory infection caused by *E. coli* in a mouse mastitis model as well as in lactating dairy cows (118, 119). This novel approach may be of critical importance in minimizing the impact of infections caused by Gram-negative bacteria. As

CD14 is a protein found naturally in bovine milk (220) and is expressed on bovine macrophages (153), any side effects involving therapeutic applications of sCD14 should be minimal.

The goal of our study was to express the rbosCD14 protein in plants. Plants represent one of the most plentiful and affordable sources for large, agricultural-scale production of biological products (131). Taking into account the previously reported therapeutic effect of sCD14 against coliform mastitis (118, 119), expression of rbosCD14 in plants and its purification was aimed at reducing the cost of production of rbosCD14 for the treatment of mastitis in lactating dairy cows. Unlike any other available means of CD14 manufacturing (bacterial and yeast cultures, insect cells), plants are inexpensive, offer animal and human pathogen-free biomass, and lack LPS.

MATERIALS AND METHODS

Construction of prbosCD14, polymerase chain reaction (PCR) and reverse transcriptase (RT)-PCR.

The previously cloned cDNA encoding a truncated form of the CD14 ORF lacking 33 C-terminal amino acids (rbosCD14) (219) was amplified using the CD14-specific sense primer LN53 5'GCGATATCAACAATGGTGTGCGTGCCCTACCTG and antisense primer LN54 5'GCGATATCTTATTAGTGATGGTGGTGATGC. The LN54 primer contained the six HIS tag coding sequence present on the original clone. *EcoRV* restriction sites were included on both primers for cloning purposes. Sense primer LN53 had an internal plant consensus sequence AACAATGG which included the ATG initiation codon (bold) to modulate mRNA translational

efficiency in plants (Figure 9). For detection of CD14 mRNA in plants, cDNA was synthesized from total RNA isolated from leaf tissue using TRI reagent (Molecular Research Center, Inc., Cincinnati, OH) and PCR amplified utilizing LN53/LN54 primers and Titan One RT-PCR Tube kit according to manufacturer's directions (Roche Molecular Biochemicals, Indianapolis, IN).

Cloning, *in vitro* transcription and plant inoculation

PCR-amplified rboCD14 was directly cloned into the TOPO 2 vector (Invitrogen, Carlsbad, CA) followed by subcloning into *EcoRV*-linearized plant virus expression vector PVX pP2C2S. The integrity of all clones was verified by nucleotide sequencing (ABI-PRIZM 373A Genetic Analyzer, DNA sequencing facility, Center for Agricultural Biotechnology, University of Maryland, College Park, MD). Capped transcripts from recombinant PVX/CD14 virus were generated *in vitro* with RNA mMessage Machine T7 kit (Ambion, Austin, TX) and used to inoculate three top leaves of *Nicotiana benthamiana* plants. Inoculated plants were kept in a containment greenhouse facility at MPPL, USDA/ARS, Beltsville, MD.

Purification and Western blotting analysis of plant-derived CD14 protein

Histidine-containing the prboCD14 was purified from plant extracts using a Ni-NTA purification system (Invitrogen). Leaf tissues were ground in liquid nitrogen and homogenized in PBS buffer containing a 1:100 dilution of protease inhibitor cocktail (Sigma). The crude extracts were filtered through miracloth and, after two rounds of centrifugation (4,000 x g/20 min and 10,000 x g/20 min), cleared lysates were incubated

with 2 mL of Ni NTA resin for 2 h at 4°C and subsequently applied to 10 mL purification columns. Column resin was washed three times with 1 x PBS containing 20 mM imidazole. Bound protein was eluted in 1 mL fractions with 1 x PBS containing 250 mM imidazole.

Crude plant extracts and purified proteins were analyzed by Western blotting using a 10-20% Tris-glycine gel according to manufacturer's instructions (Invitrogen). Nitrocellulose membranes were probed with rabbit polyclonal antisera raised to rboCD14 in a 1:1000 dilution overnight at 4°C following by 2 h incubation with a 1:5000 dilution of goat anti-rabbit secondary antibody conjugated with alkaline phosphatase (Kirkegaard and Perry Laboratories, Gaithersburg, MD). Membranes were then developed with the BCIP/NBT Substrate System (Kirkegaard and Perry Laboratories).

IL-8 ELISA

Bovine aortic endothelial cells (generous gift of Dr. L.M. Sordillo, Michigan State University, East Lansing, MI) were seeded into 96-well plates at a density of 25,000 cells/well and cultured for 24 h. Following treatment, plates were centrifuged (220 x g, 10 min) and the supernatants analyzed using a commercially available kit for human IL-8 (R&D Systems, Inc., Minneapolis, MN). The antibody pairs used in this kit have been previously shown to cross-react with bovine IL-8 (192). OD at 450 nm and a correction wavelength of 550 nm were measured on a microplate reader (Bio-Tec Instruments, Inc., Winooski, VT). Values expressed in pg/mL were extrapolated from a standard curve of known amounts of human IL-8.

Endothelial injury/apoptosis assays.

For the determination of LPS-induced endothelial injury, endothelial cells were seeded into 96-well plates as above and monolayers were visualized on a Nikon Eclipse TE200 inverted phase-contrast microscope (Nikon, Inc., Melville, NY). LPS-induced endothelial injury was evidenced by cell rounding and detachment as previously reported (12). For the specific assaying of apoptosis, endothelial caspase activity was measured with a fluorimetric homogenous caspases assay according to the manufacturer's instructions (Roche Molecular Biochemicals, Indianapolis, IN). The plates were analyzed on a fluorescence microplate reader (Bio-Tec Instruments) at 485 nm excitation and 530 nm emission, and caspase activity expressed relative to simultaneous media controls.

***In vivo* studies.**

Clinically healthy Holstein cows, which were free of intramammary infections and had mammary quarter milk somatic cell counts (SCC) <200,000 cells/mL, were selected for the study. To quantify somatic cells, milk samples were heated to 60°C and subsequently maintained at 40°C until counted on an automated cell counter (Fossomatic model 90, Foss Food Technology, Hillerod, Denmark) as previously described (141). Mammary quarters were infused with 0.3 µg of LPS derived from *E. coli* 0111:B4 (Sigma) dissolved in 10 mL of PBS or LPS pre-incubated (2 h at 37°C) with rboCD14 (100 µg) in 10 mL of PBS. Milk samples were collected at various time points and analyzed for MSCC.

Other studies were conducted to determine whether prbosCD14 could enhance bacterial clearance. Prior to intramammary challenge, 10 mL of brain heart infusion broth (Becton-Dickinson Diagnostic Systems, Inc., Sparks, MD) were inoculated with *E. coli* strain P4 and incubated for 6 h at 37°C. This strain was originally isolated from a clinical case of mastitis and has been used in other studies of mastitis (24, 25). One milliliter of the incubated culture was transferred to an aerating flask containing 99 mL of tryptic soy broth (TSB) and incubated overnight at 37°C. After incubation, the flask was placed in an ice water bath and mixed by swirling. A 1 mL aliquot from the flask was serially diluted in PBS and 1 mL of the resulting dilutions mixed with 9 mL of pre-melted trypticase soy agar in petri dishes. The plates were allowed to solidify at room temperature and then transferred to a 37°C incubator overnight. The aerating flasks containing the stock cultures were maintained at 4°C overnight. The concentration of the stock cultures was determined based on the prepared pour plates. Immediately following the morning milking, quarters were infused with either 10 mL of PBS ($n = 3$) or sCD14 (100 µg) ($n = 3$) followed by infusion of 75 CFU of *E. coli* suspended in 2 mL of PBS. Following challenge, aseptic milk samples were collected at various time points, serially diluted, and plated on blood agar plates. Following a 16 h incubation at 37 °C, colonies were enumerated.

Statistical analysis.

For the analysis of *in vitro* studies, including IL-8 production and caspase activity, a one-way analysis of variance (ANOVA) was used to compare the mean responses among experimental groups using GraphPad Prism version 4.00 for Windows (GraphPad

Software). For the *in vivo* studies comparing the effects of prbosCD14 on milk SCC and bacterial clearance, repeated measures ANOVA was performed using the PROC MIXED model (SAS 8.2; SAS Institute, Cary, NC). For statistical analysis of milk SCC and bacterial CFU, data were transformed to log₁₀ values. A *P*-value of <0.05 was considered significant.

RESULTS

Expression and purification of recombinant sCD14 in plants

The truncated form of rbosCD14, lacking the last 33 aa at the carboxy terminus and encoding the N-terminal 358 amino acids of bovine CD14, and engineered to carry six histidine affinity residues for ease of purification (219), was modified to place the CD14 initiation codon in a “plant” consensus context of AACAAATGG to increase the efficiency of mRNA translation in plants (125) (Figure 9). In addition, an extra TAA termination codon was added to insure a proper translation termination (Figure 9). The construct was placed under transcriptional control of the subgenomic coat protein promoter of the plant virus vector, *Potato Virus X* (PVX, 19) for transient expression in *Nicotiana benthamiana*. Plants were inoculated with *in vitro* synthesized, capped viral T7 RNA transcripts and tested for protein expression after showing systemic infection.

Symptoms indicative of PVX infection were first visible as distinct vein clearing at 5-7 days post inoculation (dpi). Plants eventually became systemically infected, developing symptoms indistinguishable from the wild type virus, including vein clearing, green mosaic, leaf curling and general stunting appearance within 10-14 dpi (data not shown). No difference in timing or symptom expression was evident between plants

infected with PVX only and plants infected with PVX/CD14, indicating a potent infectivity of the recombinant virus. RT-PCR assay performed with CD14-specific primers confirmed the presence of CD14 mRNA, which was absent in the uninfected control plant as well as in plants inoculated with PVX only (data not shown).

Western blotting analysis of recombinant protein from infected plants

Western blot analysis utilizing rboCD14-specific polyclonal antibodies demonstrated that crude plant extracts as well as affinity-purified samples contained immunoreactive recombinant protein of predicted molecular mass, though slightly different in appearance compared to rboCD14 produced in insect cells (Figure 10). The concentration of prboCD14, determined by CD14-specific ELISA, varied from 15-20 µg to approximately 300-500 µg/mL of affinity-purified pure recombinant protein preparation (data not shown). The purified prboCD14 did not contain LPS.

From the results of multiple Western blotting experiments, recombinant protein concentrations in primary-inoculated plants remained stable for about three weeks p.i. and then declined gradually. A passage of infection within this period led to a comparable protein expression level in secondary-inoculated plants during the same time interval. Transmission of virus and/or testing of protein at late stages of infection resulted in significantly lower expression apparently due to a loss of CD14 sequence and reversal of recombinant virus to the original PVX wild-type genomic sequence.

Plant rboCD14 is a fully functional molecule that can promote LPS signaling.

Cells lacking mCD14, including endothelial cells, require sCD14 for recognition of and activation by LPS. To determine whether plant rbosCD14 could functionally promote cellular activation by LPS, endothelial cells were washed three times with serum-free media and treated with either PBS or LPS (100 ng/mL) in the presence of serum-free media containing 250 ng/mL of prbosCD14. This concentration of prbosCD14 was able to promote LPS-induced IL-8 production to a comparable degree as that of insect cell-derived rbosCD14 or endogenous sCD14 found in bovine serum (Figure 11A). Exposure to prbosCD14 alone had no effect on endothelial IL-8 production. Consistent with a requirement for sCD14 for activation, LPS did not induce IL-8 production in the absence of sCD14 (*i.e.*, serum-free media). The ability of plant rbosCD14 to promote LPS-induced IL-8 production was dose-dependent and concentrations as low as 10 ng/mL were able to elicit this response (Figure 11B).

In addition to the induction of IL-8, LPS is reported to induce endothelial injury and apoptosis. Whereas IL-8 production is mediated through the NF- κ B signaling pathway, LPS-evoked pro-apoptotic signaling occurs through an NF- κ B-independent pathway (13). To determine whether prbosCD14 could promote LPS signaling through this NF- κ B-independent pathway, endothelial cells were treated as above and assayed biochemically for caspase activation, an indicator of apoptosis (Figure 11C) and visually for evidence of injury (Figure 12). Similar to IL-8 production, prbosCD14 was able to promote LPS-induced apoptosis and injury to a similar extent as that of endogenous sCD14 found in bovine serum or insect cell-derived rbosCD14.

Plant rbosCD14 enhances LPS-induced milk SCC and promotes clearance of *E. coli* *in vivo*

Previous studies have established the ability of sCD14 to enhance host responses to bacterial LPS. LPS has been demonstrated to induce an acute inflammatory response in the mammary glands of cows that is characterized by an increase in milk somatic cells, greater than 90% of which are PMN. To determine whether prbosCD14 could enhance PMN recruitment as indicated by increased milk somatic cell counts, 0.3 µg of LPS was infused into the quarters of lactating dairy cattle in combination with either PBS or sCD14 (100 µg). Initial studies established that intramammary infusion of saline or prbosCD14 alone had no effect on milk somatic cell counts (data not shown), similar to results obtained for insect cell-derived rbosCD14 (219). LPS elicited an increase in milk SCC and this response was enhanced by prbosCD14 (Figure 13). The overall significant difference between the two treatment groups ($P = 0.0121$) is comparable with results obtained using insect cell-derived rbosCD14 (117, 219).

In addition to its ability to enhance the responses to LPS, CD14 has been demonstrated to facilitate *E. coli* clearance (119). To determine whether prbosCD14 could similarly enhance bacterial clearance, mammary glands were infused with either saline or prbosCD14 (100 µg), and subsequently infused with 75 CFU of *E. coli*. There was an overall significant decrease ($P = 0.0265$) in the number of viable *E. coli* recovered from quarters infused with prbosCD14 compared with those receiving saline (Figure 14), and an absence of clinical symptoms (not shown). In addition, there were no obvious adverse effects of the engineered protein carrying the histidine tag in either the *in vitro* or *in vivo* tests.

DISCUSSION

This study provides evidence, for the first time, that a functional animal receptor protein can successfully be produced in plants by transient expression from a potex virus vector. A number of biopharmaceuticals, including vaccines and therapeutic proteins, have been expressed in plants (132, 207), the primary motivation being the expression of potentially effective and useful proteins of non-plant origin in a plant system. Many reports have demonstrated the suitability of plants as vehicles for synthesizing particular proteins; however, follow-up studies of the biological activity of the recombinant protein in the targeted host animal and subsequent disease challenge are less common. The objective of our study was not only to achieve plant expression of the bovine CD14 receptor, but also to demonstrate the application of the plant-produced CD14 in the treatment of intramammary bacterial infection of dairy cows.

The expression of the truncated, histidine-tagged, sCD14 in plants infected with the recombinant PVX virus was stable for several weeks; however, instability of the virus construct occurred upon subsequent passage to new plants. ELISA tests designed to measure affinity purified CD14 resulted in estimates of 10-20 $\mu\text{g/mL}$ and up to 300-500 $\mu\text{g/mL}$ of purified CD14. On average, the results indicate at least a 10-fold smaller concentration, between 1-10 $\mu\text{g/gm}$ fresh weight tissue, or roughly 0.125 % total soluble protein. It is not known what contributes to this discrepancy in values, although variable efficiency of affinity purification to obtain the final product may contribute. The estimate of 20 $\mu\text{g/mL}$ of purified CD14 was used to calculate amounts of prbosCD14 for subsequent *in vitro* and *in vivo* tests.

The protective effect of rbosCD14 produced in a baculovirus expression system was previously demonstrated in a mouse model and in lactating dairy cows (117, 118). Our findings indicate that prbosCD14 is a biologically active protein, possessing characteristics similar to rbosCD14. Endothelial cells lacking mCD14 can only respond to LPS in the presence of sCD14. In the presence of prbosCD14, LPS induced apoptosis, caspase activity, and IL-8 production in bovine endothelial cells, demonstrating the capability of prbosCD14 to complex with LPS and mediate LPS-induced cell activation. Leukocyte recruitment from the blood to the mammary gland is an important component in the defense response of the host against intra-mammary infections. *In vivo*, prbosCD14 enhanced LPS-induced recruitment of leukocytes to the mammary glands.

After functional activity of prbosCD14 was confirmed *in vitro* using epithelial cell culture and *in vivo* by intramammary injection of LPS, the protective effect of prbosCD14 was tested in a bovine mastitis model. Infusion of prbosCD14 into *E. coli*-challenged mammary glands significantly reduced the number of viable bacteria recovered relative to quarters infused with *E. coli* and saline. In addition, there was an absence of clinical symptoms in prbosCD14/*E. coli* quarters in contrast to saline/*E. coli* quarters indicating a protective effect of the plant-produced protein.

Mastitis continues to be the most costly disease in animal agriculture. Currently, treatment of coliform mastitis caused by Gram-negative bacteria, which are responsible for the majority of the cases of clinical mastitis, remains sub-optimal. Thus, the lack of effective control measures reinforces the urgent need to develop new therapeutic modalities. Results reported in this study suggest that prbosCD14 can be a potent tool in minimizing the impact of infections caused by Gram-negative bacteria.

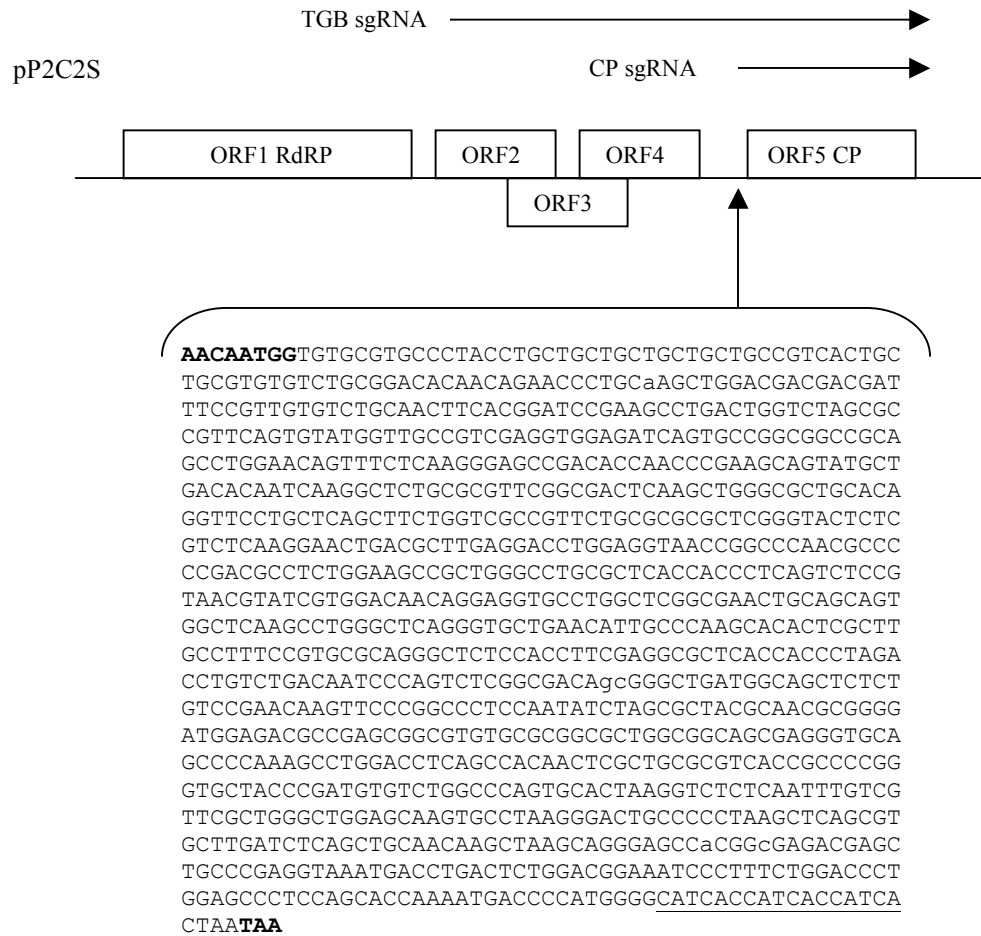

Figure 9. Structure of the truncated rboSCD14, lacking the 33 3' terminal amino acids, incorporated into the PVX pP2C2S vector. The ATG codon was placed in the surrounding plant translational consensus sequence (bold); an extra TAA stop codon was introduced at the 3' terminus (bold). The construct also contains the exons for six histidine residues (underlined). Transcription of sCD14 is driven by the duplicated coat protein (CP) subgenomic promoter located upstream of the open reading frame (ORF) 5 CP. Also indicated on the linear map are the locations of the ORF 1 RdRp (replicase), ORF2, ORF3 and ORF 4 of the triple gene block of PVX.

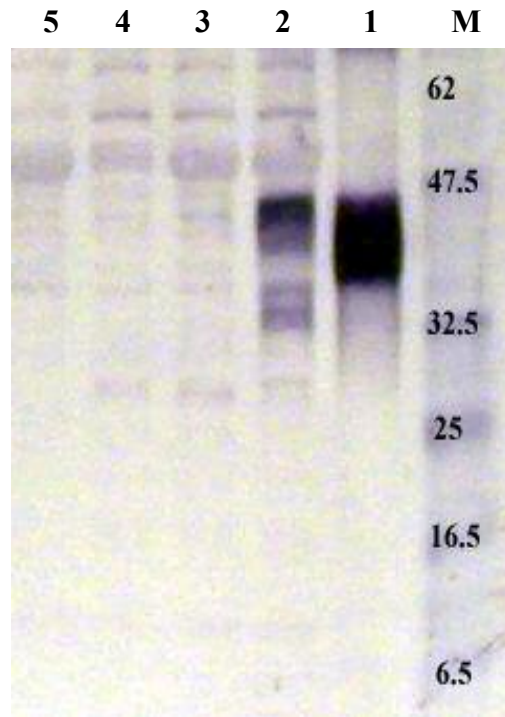
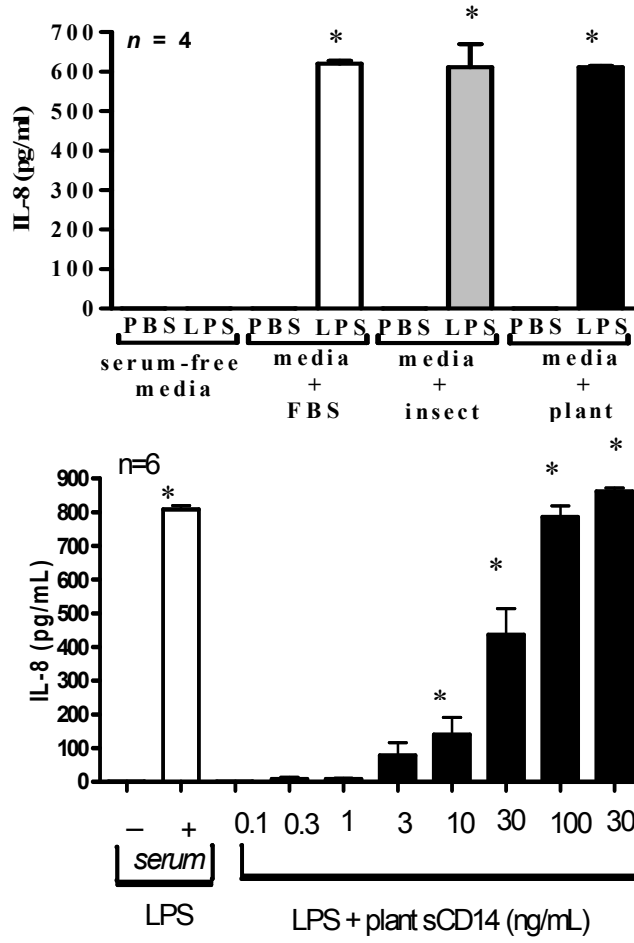

Figure 10. Western blotting analysis of samples from PVX/CD14-infected plants, probed with CD14-specific polyclonal antisera. M, Protein marker (New England BioLab). 1, CD14 positive control, ~46 kDa, ~200 ng/load; 2, PVX/CD14-infected plant; 3 and 4, plant infected with PVX only; 5, non-infected plant

A



C

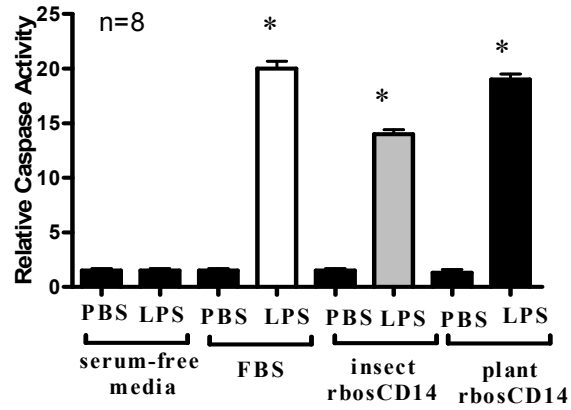
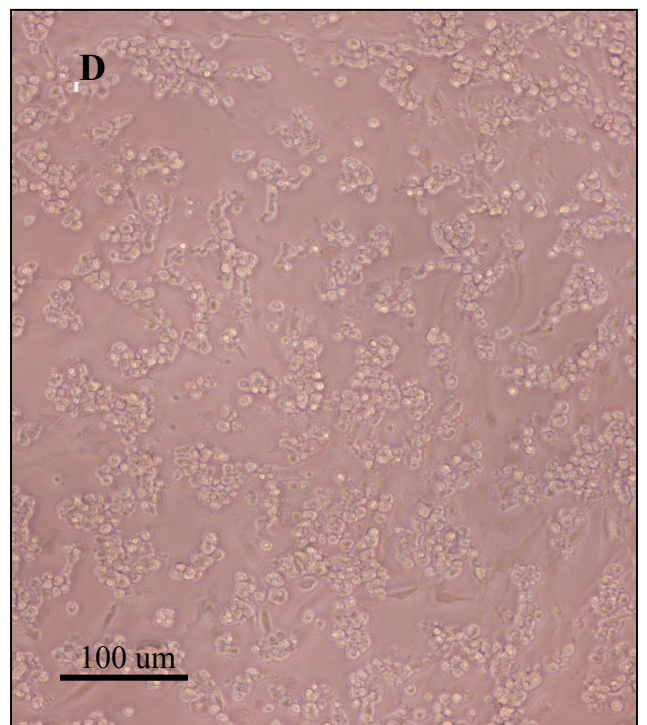
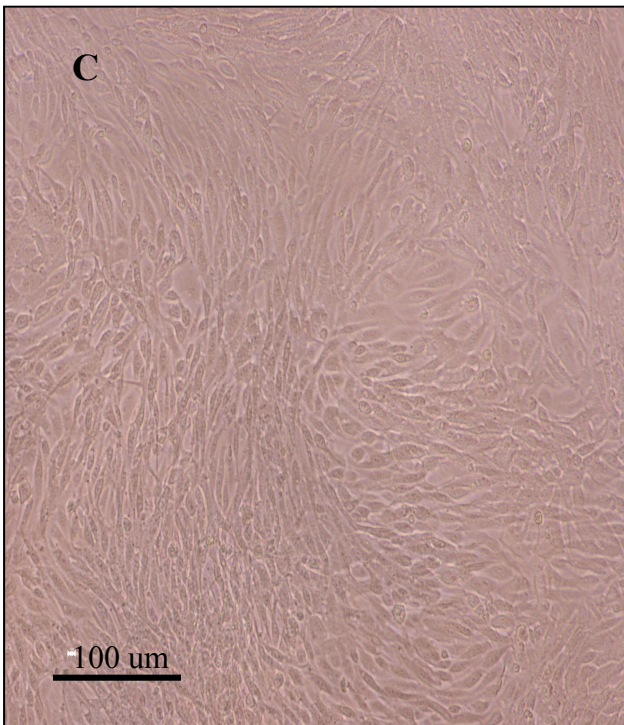
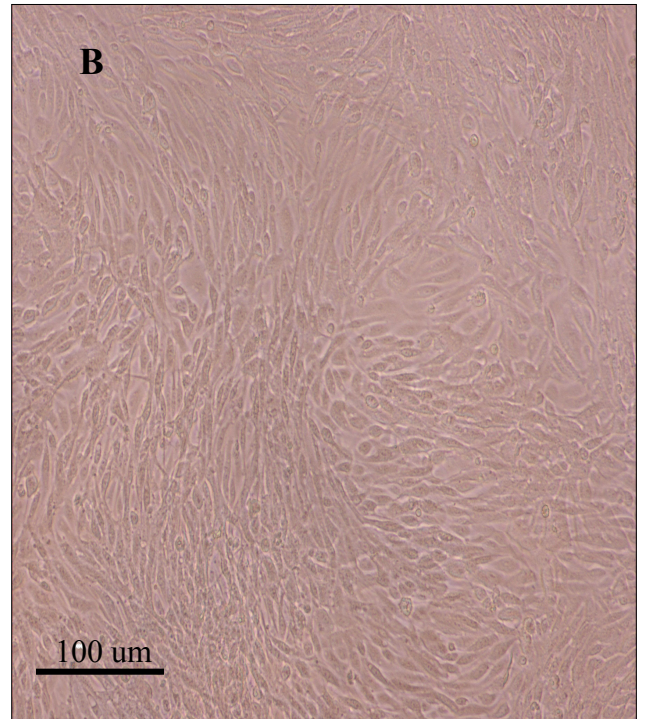
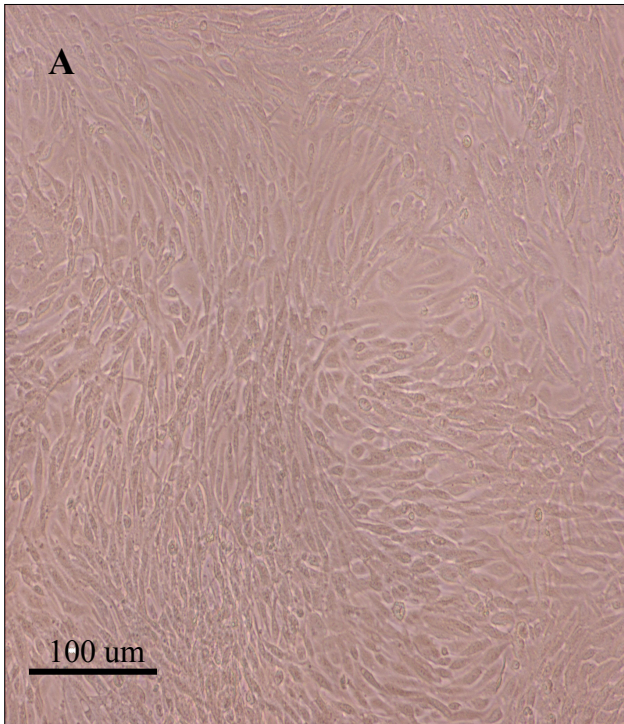

Figure 11. Effect of plant-derived rbosCD14 on LPS-induced IL-8 production and caspase activation. Bovine aortic endothelial cells were exposed to PBS or LPS (100 ng/mL) for 16 h in the presence or absence of serum, or in serum-free media containing insect cell- or plant-derived rbosCD14 (250 ng/mL) (A, C). In other experiments, endothelial cells were exposed to LPS (100 ng/mL) in serum-free media containing increasing concentrations of plant-derived rbosCD14 (B). Vertical bars represent mean (+S.E.) IL-8 production expressed in pg/mL (A, B) or mean caspase activity expressed relative to simultaneous PBS controls (C). * = Significantly increased compared to endothelial cells exposed to LPS in serum-free media ($P < 0.05$).



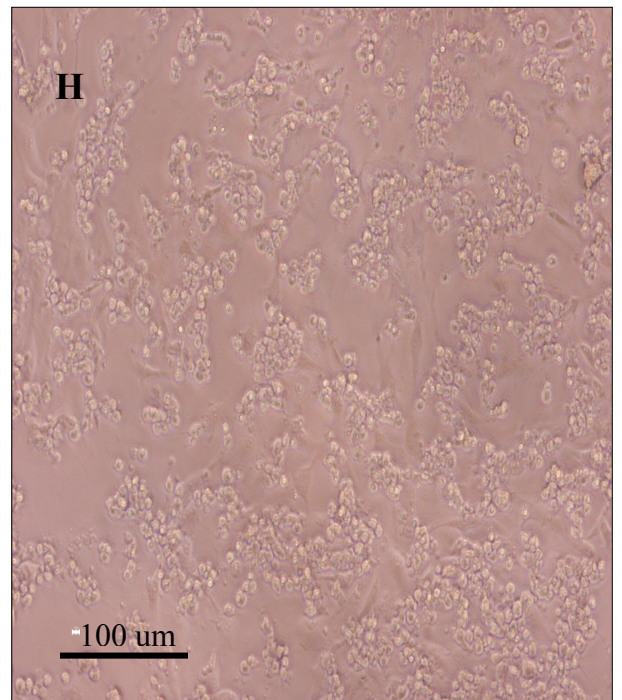
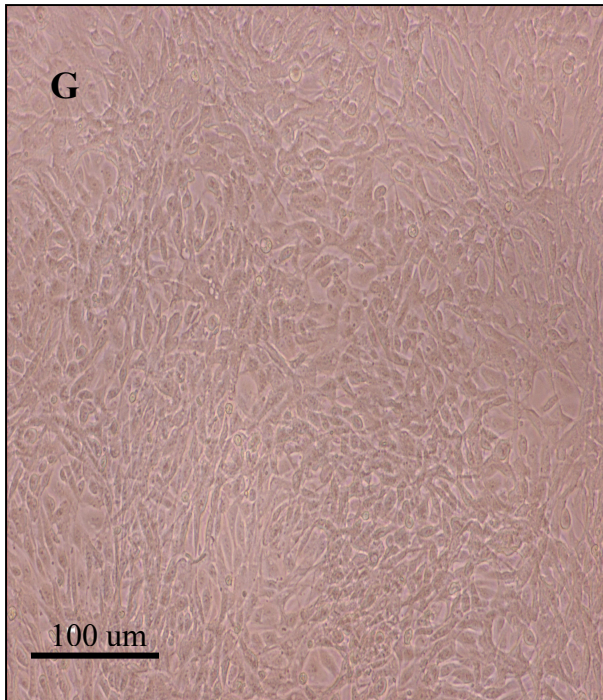
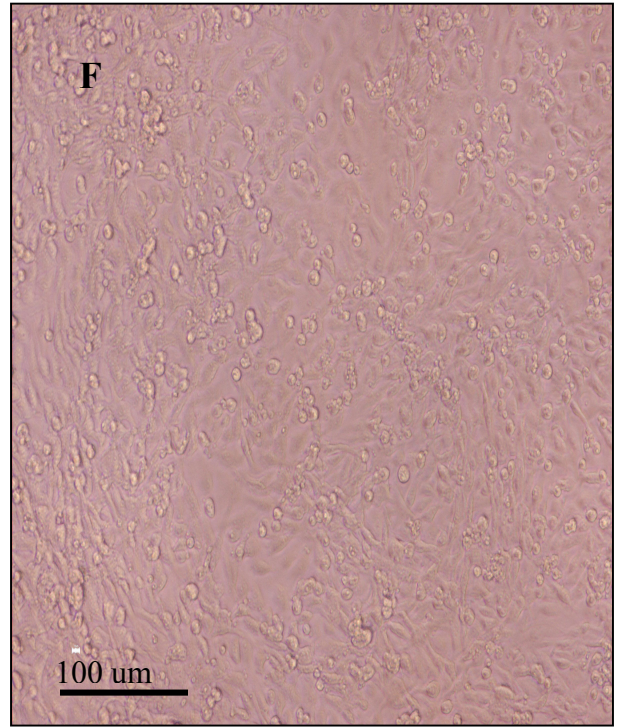
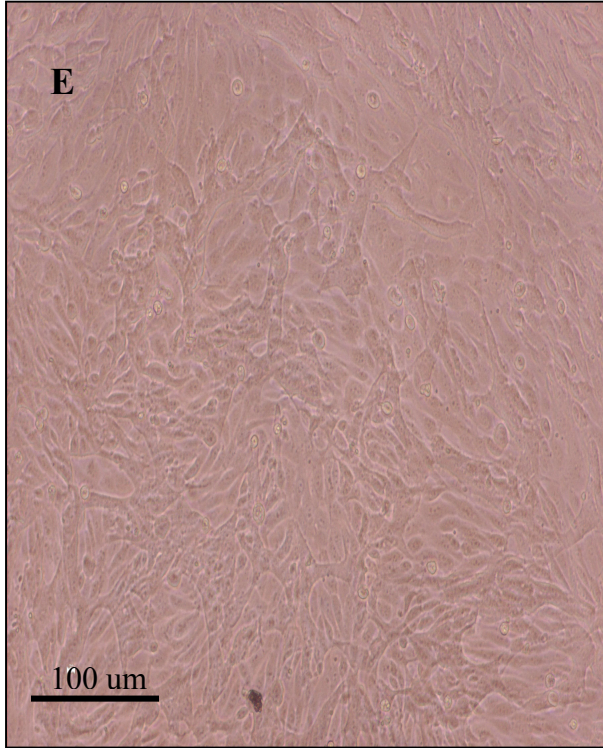

Figure 12. Effect of plant-derived rbosCD14 on apoptosis on endothelial cells. Bovine aortic endothelial cells were exposed for 16h (A) in the serum free media with PBS, (B) in the serum free media with LPS (100 ng/mL), (C) in the media containing serum with PBS, (D) in the media containing serum with of LPS (100 ng/mL), (E) in the media containing PBS with insect cell-derived rbosCD14 (250 ng/mL), (F) in the media containing LPS (100 ng/mL) with insect cell-derived rbosCD14 (250 ng/mL), (G) in the media containing PBS with plant-derived rbosCD14 (250 ng/mL), (H) in the media containing LPS (100 ng/mL) with plant-derived rbosCD14 (250 ng/mL).

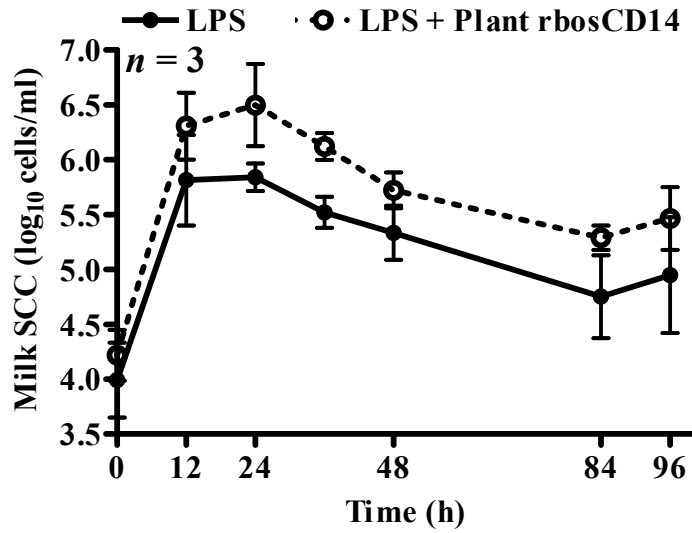

Figure 13. Effect of plant-derived rbosCD14 on LPS-induced increases in milk somatic cell counts (SCC). Three glands were infused with LPS (0.3 μ g) or a combination of LPS and plant-derived rbosCD14 (100 μ g). Milk samples were collected immediately prior to (time 0) and at various time points following infusion and analyzed for milk SCC. Mean (\pm S.E.) milk somatic cell counts are reported in thousands/mL.

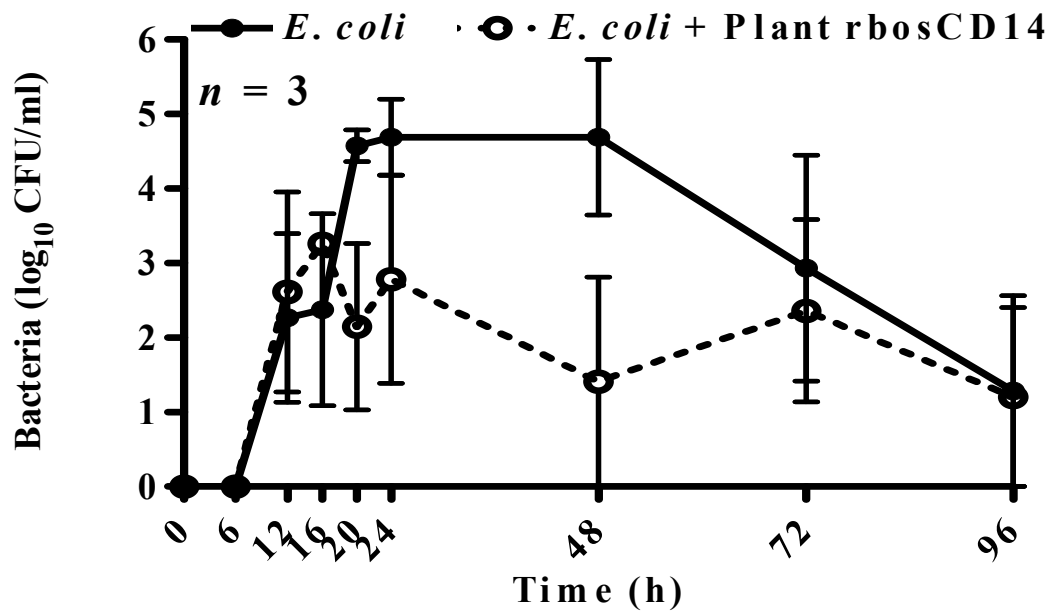

Figure 14. Effect of plant-derived rbosCD14 on *E. coli* intramammary viability. Three glands were infused with either saline or plant rbosCD14 (100 μ g) and subsequently infused with 75 CFU of *E. coli*. Milk samples were collected aseptically immediately prior to (time 0) and at various time points following infusion and plated for the enumeration of viable bacteria. The mean (\pm S.E.) of log₁₀ CFU/mL is shown.

Chapter Four: Shedding of sCD14 by Bovine Neutrophils Following Activation with LPS Results in Down-Regulation of IL-8

ABSTRACT

The expression of CD14 on the surface of PMN increases after exposure to some inflammatory stimuli such as N-formyl-methionyl-leucyl-phenylalanine (fMLP). These newly expressed molecules probably originate from an intracellular pool of preformed receptors. We sought to characterize bovine PMN cell surface expression and shedding of CD14 molecules and its effect on secretion of IL-8 by PMN. Bovine PMN were incubated in RPMI for 20 h at 37°C with LPS (1,10, and 100 µg/mL) in the presence or absence of 5% FBS. The culture supernatant was assayed for IL-8 and sCD14 by ELISA. At 20 h, IL-8 release decreased 41.5 and 95% in the absence of FBS, and 4.3 and 35.5%, respectively in the presence of FBS at the 10 and 100 µg/mL of LPS compared to the 1 µg/mL of LPS. Shedding of CD14 from the surface of PMN increased in the absence of FBS at the highest concentration of LPS (100 µg/mL). The use of real time polymerase chain reaction showed that CD14 mRNA was not different between control and LPS stimulated cells after 1 h, suggesting that the sCD14 came from membrane-bound CD14 (mCD14). Bovine PMN apoptosis, as determined with annexin-V, was induced in the presence of FBS, and was slightly inhibited in the absence of FBS after 6 h of incubation with all concentrations of LPS. CD18 expression was up-regulated with different concentrations of LPS, but the shedding of L-selectin increased with increasing cell density. Secretion of PGE₂ decreased in a LPS dose-dependent manner in the absence of serum, and increased in a LPS dose-dependent manner in the presence of serum and with increasing cell density. The shedding of CD14 by PMN increased at 6 h and then slowly

decreased until 20 h. Shedding of CD14 by PMN after exposure to LPS increased 93%, and secretion of IL-8 decreased 93% at a cell density of 10×10^7 PMN/mL of PMN. Secretion of IL-8 from PMN was not detected at 6 h and IL-8 secretion decreased at high concentrations of LPS. The secretion of IL-8 was reduced in RPMI media without FBS compared to media with FBS. Our results demonstrate the release of CD14 from the surface of PMN in response to LPS, that IL-8 production was suppressed by LPS and that sCD14 in the absence of FBS was more effective in suppressing secretion of IL-8 than in the presence of FBS.

INTRODUCTION

The recruitment and activation of polymorphonuclear neutrophil leukocytes (PMN) are important for nonspecific host defense against infectious agents. PMN are short-lived blood cells that play a vital role in the inflammatory response. They are one of the first cells recruited to the site of injury or infection. PMN activation results in increased phagocytosis, bacterial killing, release of lysosomal enzymes, and generation of superoxide anion (223). A number of exogenous and endogenous peptide and lipid mediators, such as fMLP, C5a, leukotriene B₄ and cytokines are chemoattracts for PMN and are referred to as chemokines (8). IL-8 is the best characterized among the PMN attracting chemokines. IL-8 belongs to the CXC family of chemokines, and simulates PMN adherence, degranulation, respiratory burst, and lipid mediator synthesis (160). Human PMN have been reported to synthesize IL-8, TNF- α , IL-1 β , macrophage-colony stimulating factor (m-CSF), and granulocytes-CSF (G-CSF), as well as an IL-1 receptor

antagonist (36). Activated PMN express many molecules on their cell surfaces (143) and release soluble factors such as cytokines (33) and proteases (223).

Many functionally important receptors for microbial ligands have not yet been identified on PMN (138). TLRs have been identified on mammalian monocytes and PMN. TLRs mediate cellular responses to a large array of microbial ligands. TLR2 is the receptor for a variety of microbial ligands, including Gram-positive bacteria, peptidoglycan and zymosan. TLR4 is a receptor for Gram-negative bacteria and LPS. TLR4 and TLR2, like other TLR family members, have a conserved intracellular signaling motif. TLR4 and LBP activate the intracellular signaling pathways in PMN (189). TLR4 and CD11b/CD18 are the other key receptors that bind to LPS, and activate the intracellular signaling pathways in PMN (175).

The other important receptor for a microbial ligand is CD14. CD14 is GPI-anchored protein expressed at high levels on the surface of circulating monocytes and macrophages. PMN contain an intracellular pool of CD14 found in azurophile granules (174). sCD14 which is present in serum, is also present in both the plasma membrane-secretory vesicles of human PMN (174). mCD14 and sCD14 function as co-receptors for microbial ligands. sCD14 can neutralize LPS-LBP complexes, thus preventing over stimulation of the inflammatory response (129, 183) and can insert into the plasma membrane of cells that do not express CD14 such as endothelial cells and stimulate release of cytokines (75).

Prostaglandins are multipotential mediators in many biological responses. In Gram-negative infection, they play a major role in the inflammatory responses (62).

Recently, cytokines released by human PMN have been characterized, but have not been characterized for bovine PMN. Our study demonstrates that down-regulation of IL-8 secretion by bovine PMN after LPS stimulation is sCD14 dependent, and involves PGE₂, L-selectin, and CD18. We also report that sCD14 is shed from the surface of bovine PMN and not from an intracellular pool as determined by RT-PCR.

MATERIALS AND METHODS

Animals

Sixteen clinically normal pregnant mid- to late-lactating Holstein cows (220 ± 60 days in milk) were used.

Blood sampling and PMN isolation

Blood was collected from the tail vein by venipuncture in heparinized vacutainer tubes. Blood was centrifuged at 500 x g for 5 min at 4°C. Plasma, buffy coat, and 1/3 of the red blood cells were removed. The pellet in the remaining blood was suspended dropwise into a double volume of cold 0.2 % NaCl solution and gently mixed for about 1 min for lysis red of blood cells. Immediately, half the original volume of 3.7 % cold NaCl solution was added to restore isotonicity. The suspension was centrifuged for 1min at 200 x g at 4°C and the pellet was washed twice with 20 mL of PBS. Smears were prepared from the pellet and stained with Hemacolor (Merck, D-64293 Darmstadt 1, Germany). Differential microscopic counts were determined by counting 100 cells. Purity of the isolated PMN was 94 %.

Cell culture and stimulation studies

For cell density studies, PMN were resuspended in RPMI either with or without heat inactivated (56°C, 30 min) 5% FBS and plated onto 96-well tissue culture plates at 1×10^7 , 5×10^7 and 10×10^7 PMN/mL (200 μ L/well) containing 0, 0.1 and 10 μ g/mL of LPS, and incubated at 37°C for 16 h in a 5% CO₂ incubator. PMN (5×10^6 PMN/mL) were cultured with media alone (control) or stimulated with 1, 10, 100 μ g/mL of LPS for either 6 or 20 h at 37°C. Cells and cell supernatants were separated by centrifugation at 500 x g and supernatants were stored at -20°C until further processing.

Apoptosis of PMN isolated from blood

After stimulation of PMN for 6 or 20 h at 37°C with the various concentrations of LPS in the presence or absence of heat inactivated 5% FBS, apoptosis was quantified using a dual-color flow cytometric procedure with staining of phosphatidylserine by Annexin-V-FLUOS staining kit (Roche, Penzberg, Germany).

Flow cytometric analysis

One million PMN were incubated with different concentrations of LPS for 20 h and reacted at 4°C for 30 min with either anti-rbosCD14 mAb (198) (1:10), anti-CD18 mAb (1:100), L-selectin mAb (220)(1:1 and 1:100) or PBS (control). The cells were washed 3 x with PBS. FITC-labeled affinity-purified antibody to mouse IgG +IgM (H+L) (KPL Inc) was added to the cells at a 1:100 dilution in PBS. After 30 min of incubation at 4 °C, the wells were washed 3 x with PBS and resuspended in 200 μ L PBS. Flow cytometric analysis was performed using a Coulter Epics Profile I-Argon laser flow cytometer (Coulter Electronics Inc).

cDNA synthesis and real time reverse transcription-PCR

PMN (5×10^7) were seeded into each of 96 wells and incubated for 1 h at 37°C in RPMI1640 in the presence or absence of 5% heat inactivated FBS with 1 or 10 µg/mL of LPS. Total RNA was extracted from cells using the Rneasy mini kit (Qiagen Inc., Valencia, CA, USA). RNA quantity and quality were determined using a 2100 Bioanalyzer (Agilent Technologies, Palo Alto, CA, USA).

Reverse transcription was conducted using 150 ng of total RNA and the iScript cDNA Synthesis kit (Bio-Rad Laboratories, Hercules, CA, USA) in a 20 µL reaction volume according to kit instruction. For each reaction, a parallel negative control reaction was performed in the absence of reverse transcriptase. The subsequent PCR reactions were conducted in duplicate iQ SYBR Green Supermix (Bio-Rad Laboratories) using 2 µL of cDNA and 1 µM each primer, in a 25 µL reaction volume. The primer sequences were: 5'-CTCCAGCACCAAATGAC-3' (forward) and 5'-TCCTCTTCCCTCTCTTCC-3' (reverse). Cycling conditions was performed in the iCycler iQ detection system (Bio-rad Laboratories) using the following conditions: 95°C for 3 min, followed by 45 cycles of 15s at 94°C, and 30s at 54 °C and 30s at 72°C. Identification of the 145-bp amplification products was confirmed by direct sequencing using a CEO8000 automated sequencer and DTCS Quickstart chemistry (Beckman Coulter, Inc., Fullerton, CA, USA). Quantification of samples was conducted using the iCycler Software from an external standard calibration curve analyzed simultaneously. Standards were synthesized from gel-purified CD14 PCR amplification products and ranged from 100 to 1×10^7 copies. Efficiency of amplification for all assays was >95.9% and the correlation coefficient was > 0.99%.

Soluble CD14 ELISA

Flat-bottom 96-well plates were coated with 5 µg/mL of mouse anti-rbos CD14 mAb (CAM36A clone; VMRD, Inc., Pullman, WA) diluted in 0.05 M sodium carbonate, pH 9.6 at 4 °C. The plates were washed 4 x with 0.05% Tween 20 diluted in 50 mM TBS, pH 8.0, and subsequently blocked with 2% fish skin gelatin (Sigma) for 1 h at room temperature. Plates were washed and 100 µL of supernatant samples was added to each well and incubated for 2 h at room temperature and was washed 3 x with TBS. Rabbit anti-bovine CD14 polyclonal antibody (198) was diluted 1:2000 in TBS buffer containing 0.2% gelatin, and 100 µL was added to each well and subsequently was washed as above. One-hundred µL of HRP-conjugated goat anti-rabbit IgG (H+L; Promega) diluted in PBS containing 0.2% gelatin (1:5000) was added to each well. Plates were incubated for 1 h at room temperature, washed as above, and 100 µL of TMB substrate solution was added to each well. The reaction was stopped by the addition of 50 µL of 2 N H₂SO₄ and the absorbance read at 450 nm on a microplate reader (Bio-Tek Instruments).

IL-8 production

PMN were stimulated with different concentrations of LPS for 20 h and at different cell density with 0.1 and 100 ng/mL of LPS. Supernatants were assayed for IL-8 with a commercially available human IL-8 ELISA kit (R&D Systems).

PGE₂ production

PMN supernatants were assayed for PGE₂ using a commercially available multi-species prostaglandin E₂ competitive ELISA kit (Endogen).

Statistical methods

The unpaired or paired sample t-test and ANOVA (Prism version 4.0 for Windows; GraphPad Software Inc.) were used for the statistical analysis; P values below 0.05% were considered significant.

RESULTS

Apoptosis of PMN

Apoptosis of bovine PMN was suppressed ($P < 0.05$) after 6 h of stimulation with all concentrations of LPS in the absence of FBS (Figure 15). In contrast, in the presence of FBS, apoptosis of bovine PMN was increased ($P < 0.05$) after 6 h of stimulation with all concentrations of LPS (Figure 15). After exposure of PMN for 20 h to all concentrations of LPS (1, 10 and 100 $\mu\text{g}/\text{mL}$) in the presence or absence of FBS, no effect was observed on apoptosis ($P > 0.05$) when compared to PMN in media alone (Figure 16).

Surface CD14 receptor expression

We examined the expression of mCD14 on PMN in the absence or presence of 5% FBS. The percentage of PMN expressing mCD14 without LPS treatment was 35.6 ± 2.6 % in the absence FBS, and 29.9 ± 0.4 % in the presene of FBS. The percentage of PMN expressing mCD14 was significantly decreased ($P < 0.001$) after stimulation with

100 $\mu\text{g}/\text{mL}$ of LPS in the absence of FBS (Figure 17A). In the presence of FBS, the percentage of cells fluorescing significantly increased ($P < 0.001$) at 1 $\mu\text{g}/\text{mL}$ of LPS, and did not differ with treatment of 10 or 100 $\mu\text{g}/\text{mL}$ of LPS (Figure 17B). There were no changes in the LMFC among the various treatments (data not shown).

Expression of mRNA CD14

Expression of CD14 mRNA in bovine PMN was studied by real time RT-PCR. We observed that there was no increase in the mRNA expression levels of CD14 mRNA when the PMN were exposed for 1 h to all concentrations of LPS treated, in the presence or absence of FBS when compared with the mRNA expression levels for control PMN (Figure 18). In the absence of FBS, mRNA expression of CD14 was less when compared to mRNA expression obtained in the presence of FBS, but the differences were not significant ($P > 0.05$).

Expression of CD18 on PMN

Granule exocytosis is an important function of activated PMN. During this process, the granule membrane incorporates into the cell membrane and increases expression of granule-membrane markers such as CD11b and CD18 (186). The expression of CD18 on PMN in the absence or presence of 5% FBS with different concentrations of LPS (1, 10 and 100 $\mu\text{g}/\text{mL}$) at 20 h was examined. CD18 by flow cytometry was significantly up-regulated ($P < 0.05$) for all concentrations of LPS-induced when compared to control value (Figure 19).

Secretion of sCD14 after LPS stimulation

In the absence of 5% FBS, PMN exhibited a significant release ($P < 0.05$) of sCD14 in response to 100 $\mu\text{g}/\text{mL}$ of LPS relative to control PMN after 20 h of incubation (Figure 20A). In the presence of FBS, the release of sCD14 was greater ($P < 0.01$) when compared to values obtained in the absence of FBS, but significant differences among various concentrations of LPS-induced were not detected ($P > 0.05$) (Figure 20B). Release of sCD14 from PMN after LPS stimulation (100 $\mu\text{g}/\text{mL}$) was increased overtime in the presence of FBS (Figure 21A), but was decreased by 16 and, 23% at 16 and 20 h, respectively in the absence of FBS when compared to sCD14 release at 6 h (Figure 21B).

Secretion of IL-8 after LPS stimulation

To investigate secretion of IL-8, PMN were incubated with different concentrations of LPS (1,10, or 100 $\mu\text{g}/\text{mL}$) in either the absence or presence of 5% FBS. IL-8 secretion from PMN did not reach detectable levels until 6 h after LPS stimulation (Data not shown). IL-8 secretion from PMN was the highest at the concentration of LPS (1 $\mu\text{g}/\text{mL}$) in the absence (670.4 ± 210.2 pg/mL) or presence (734 ± 205.7 pg/mL) of 5% FBS. Incubation of PMN with 10 and 100 $\mu\text{g}/\text{mL}$ of LPS decreased IL-8 secretion by 41.5 and 95 %, respectively in the absence of FBS, and by 4.3 and 35.5%, respectively in the presence of FBS when compared to treatment with 1 $\mu\text{g}/\text{mL}$ of LPS (Figure 22A, Figure 22B).

Effect of cell density on secretion of sCD14 and IL-8

Media at varying cell densities (10×10^7 , 5×10^7 , 2.5×10^7 , 1×10^7 PMN/mL) were obtained after 16 h incubation with 0.1 and 10 $\mu\text{g/mL}$ of LPS at 37°C. As depicted in Figure 23A, secretion of sCD14 after stimulation with 10 $\mu\text{g/mL}$ of LPS increased at the higher cell densities when compared to a cell density of 1×10^7 PMN/mL ($P < 0.001$). The increase in sCD14 was inversely related to release of IL-8 from PMN (Figure 23B). The same inhibitory effect of sCD14 on IL-8 release was also observed when PMN were stimulated with 0.1 $\mu\text{g/mL}$ of LPS (Figure 24A and 24B).

PGE₂ release from PMN after LPS stimulation

In the absence of FBS, all concentrations of LPS induced the secretion of PGE₂ from PMN ($P < 0.05$) (Figure 25A). The secretion was greatest at 1 $\mu\text{g/mL}$ of LPS, and decreased by 13.6 and 56.4% at 10 and 100 $\mu\text{g/mL}$ of LPS, respectively (Figure 25A). In the presence of FBS, PGE₂ was secreted at 2-fold higher concentrations than was observed in the absence of FBS. At concentrations of 1, 10 and 100 $\mu\text{g/mL}$ of LPS, PGE₂ averaged (230 ± 25.4 , 275 ± 15.8 , 275 ± 48.2 pg/mL) (Figure 25B). The secretion of PGE₂ increased by 57 and 42% at cell concentrations of 10×10^7 and 5×10^7 cells/mL when compared to densities of 2.5×10^7 and 1×10^7 cells/mL of PMN (Figure 25C).

L-selectin shedding from enhanced cell density

In the absence of FBS, L-selectin expression on PMN was up-regulated with treatment of 1 $\mu\text{g/mL}$ of LPS when compared to media control ($P < 0.05$) and did not differ from control at 10 and 100 $\mu\text{g/mL}$ of LPS (Figure 26A). Treatment with LPS had no effect ($P > 0.05$) on expression of L-selectin when compared to media control in the

presence of FBS. The expression of L-selectin decreased ($P < 0.05$) at 10^7 , 5×10^7 and 2.5×10^7 cells/mL PMN compared to expression at 0.5×10^7 cells/mL PMN when PMN were incubated with $0.1 \mu\text{g/mL}$ LPS for 20 h (Figure 26B).

DISCUSSION

In our experiment, we observed that LPS delayed apoptosis in the absence of FBS, and that the presence of FBS had no effect on apoptosis of PMN. Because 30% of the isolated PMN used in this study expressed mCD14, they were able to respond to LPS in the absence of FBS. In the presence of FBS, the sCD14 in the serum may have bound the LPS making it unavailable to the PMN, resulting in a failed anti-apoptotic response. LPS was found to delay apoptosis in isolated human PMN (116, 222). In contrast, using whole blood, Oostveldt (238) reported that LPS accelerated bovine PMN apoptosis. Interestingly, PMN apoptosis was induced following intramammary challenge with *E. coli*, but no effect was observed following intramammary injection of (236). The author attributed this to the appearance of TNF- α , an inducer of apoptosis, in blood after challenge with *E. coli* that was not present in blood after challenge with LPS.

TLRs are a class of receptors that recognize pathogen-associated molecules. TLR2 and TLR4 recognize LPS (229). These receptors are found on a variety of cell types including PMN. The binding of LPS to TLR is facilitated by CD14 (227). A study by Yang (229) reported that TLR2 is a signaling receptor that is activated by LPS and is dependent on LPS binding protein. From these experiments, we hypothesize that in the absence of serum, LPS can affect the TLR pathway and activate the scavenger receptor

pathway. The scavenger receptor CD36 functions as a co-receptor, acting in conjunction with TLR2, and recognizes LPS (41).

A significant finding from the present study is that mCD14 is expressed on bovine PMN, and that sCD14 comes from the shedding of mCD14 from bovine PMN and is accelerated after LPS stimulation. These findings are supported by studies that reported high mCD14 expression levels are on peripheral monocytes and intestinal macrophages derived from patients with Crohn's disease and inflammatory bowel disease (78) and that mCD14-positive PMN accumulate in the lungs of patients with acute respiratory distress syndrome. In contrast, circulating PMN exhibits low mCD14 expression due to its shedding from the cell surfaces of stimulated PMN from patients with acute respiratory distress syndrome (157). The increase in sCD14 was suggested to be associated with the accumulation of PMN at inflammatory sites (37, 118). The level of sCD14 was found to be strongly related to the concentration of PMN in the bronchoalveolar lavage from patients with acute lung injury (135) and in milk of cows containing high concentrations of PMN (118). LPS-induced the release of CD14 from human PMN, and was suggested to originate from the shedding of mCD14 and from an intracellular pool stored in the granules of PMN (53, 174). In our study LPS caused the percentage of PMN expressing mCD14 to decrease that resulted in increase in sCD14 at the highest concentration of LPS in the absence of FBS. Our study also showed that bovine PMN have an intracellular pool of CD14, and that mRNA CD14 expression did not increase after LPS stimulation. This result indicates that the source of the sCD14 may be mCD14. sCD14 found in human serum has been attributed to the shedding of mCD14 from monocytes, macrophages and PMN (59). A study by Paape et al (153) reported that bovine PMN

expressed mCD14 after migration into the mammary gland or after overnight incubation of isolated circulating PMN in milk.

Other significant observations to emerge from the present study were that IL-8 is secreted by bovine PMN, and that the release of sCD14 from PMN may cause down-regulation of IL-8 secretion from PMN. sCD14 secretion of LPS-treated PMN was increased in parallel with the decrease in IL-8 secretion (Figure 20A, Figure 22A). Further, the increase of sCD14 with increasing concentrations of PMN after LPS stimulation was also in parallel with the decrease of IL-8 (Figure 23, Figure 24). It was reported that production of IL-8 was inhibited via CD14 cleavage by human leukocyte elastase, which might be another mechanism for the down-regulatory cascade of inflammation (146). *Burkholderia cepacia* induced IL-8 synthesis in human lung epithelial cells in a CD14 and mitogen activated protein kinase dependent manner (169). A study by Katja Hattar (86) reported that IL-8 synthesis and release were dramatically reduced at high PMN density. This negative feedback mechanism reported in this and other studies is to be assumed to result in the inhibition of further PMN recruitment and activation and contributes to the control of inflammatory functions *in vivo*. Generation of IL-8 from PMN was previously shown to be regulated a wide variety of soluble agonists such as IL-4, IL-10, IL-13 and INF- γ (102,137, 224) and IL-1 and TNF- α receptors (86).

Our study demonstrated that the absence or presence of FBS influenced the release of CD14, IL-8 and the expression of mCD14. We assume that protease inhibitors from serum should affect the release of sCD14, IL-8 and expression of mCD14.

We demonstrated that there was a dose-dependent decrease in the induction of PGE₂ in PMN stimulated with LPS, and that PGE₂ was continuously secreted from PMN

at increased cell densities. It has been suggested that PGE₂ may be involved in LPS-induced septic shock through up-regulation of inflammatory cytokines via CD14 (93). This is in agreement with our study where sCD14 and PGE₂ are continuously secreted at high concentrations of PMN stimulated with LPS.

Bovine PMN adhesion molecules such as L-selectin (CD62L) and the beta₂ - integrins (CD18) play a key role in the initial contact and in the subsequent strong adhesion to post-capillary venules. Under conditions of inflammation, rolling becomes slower, leading to firm adhesion between PMN and the capillary wall. Several studies demonstrated (106,126) clear shedding of membrane bound L-selectin after PMN activation with different agents such as PMN, C5a, LTB₄, IL-1, LPS and GM-CSF. In contrast, in our study, treatment of PMN with LPS did not affect expression of L-selectin when compared to resting PMN. A possible explanation for the lack of additional shedding of L-selectin from PMN after LPS stimulation could be that the PMN were already activated by the high concentration of cytokines in plasma during pregnancy (101, 102). However, our study did show that increasing concentration of PMN in the presence of LPS decreased L-selectin expression, probably due to proteolysis at the cell membrane level (101).

LPS enhanced CD11b/CD18 expression (126). The CD11b/CD18 integrin is a critical mediator for PMN surface adherence and also communicates signaling events evoked by various cytokines (85). CD11b/CD18 integrins on PMN bind to myeloperoxidase released from PMN azurophilic granules, leading to induction of intracellular signaling cascades (115). Our experiment showed that CD18 was up-

regulated in a LPS dose-dependent manner. TLR4 signaling by LPS activates synthesis and up-regulation of CD11b and is essential for PMN adhesion and transmigration (233).

In conclusion, sCD14 release from PMN stimulated with LPS results from the shedding of membrane CD14 and suppresses secretion of IL-8 by PMN. The suppression of IL-8, a potent chemoattractant of PMN, may be important in controlling an excessive PMN response during inflammation.

A

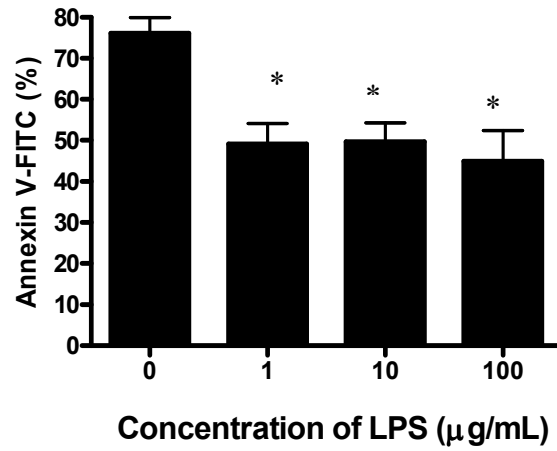

B

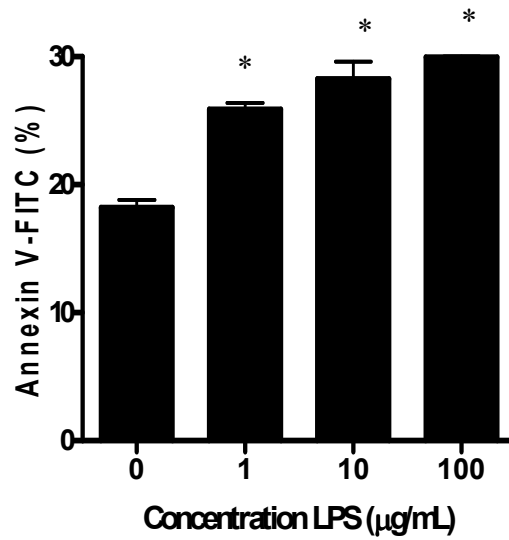
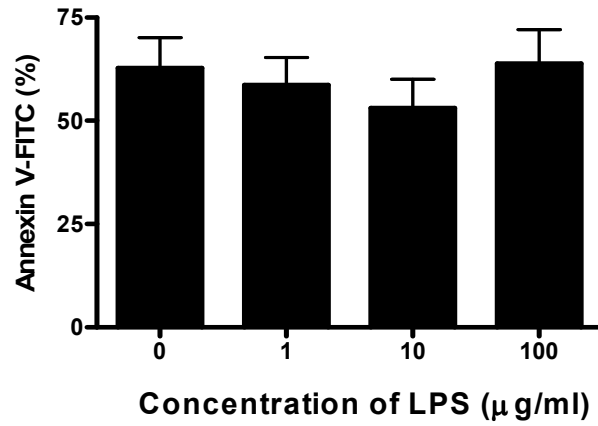

Figure 15. Percentage of apoptotic PMN (5×10^6 PMN/mL) following 6 h of incubation with varying concentrations of LPS in the absence (A) or presence (B) of FBS. Values differ from unstimulated PMN (* $P < 0.05$). Means \pm SEM of five individual experiments.

A



B

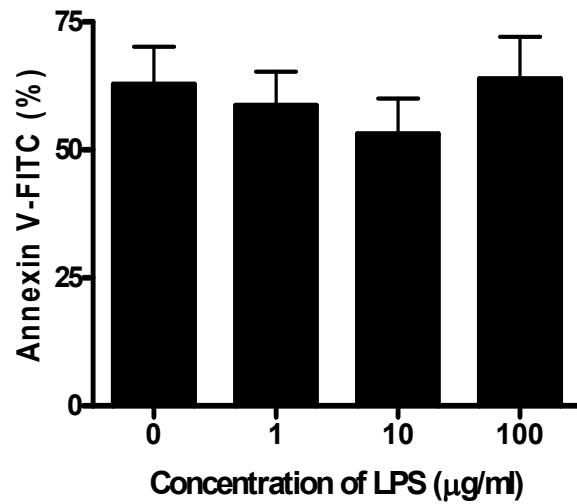
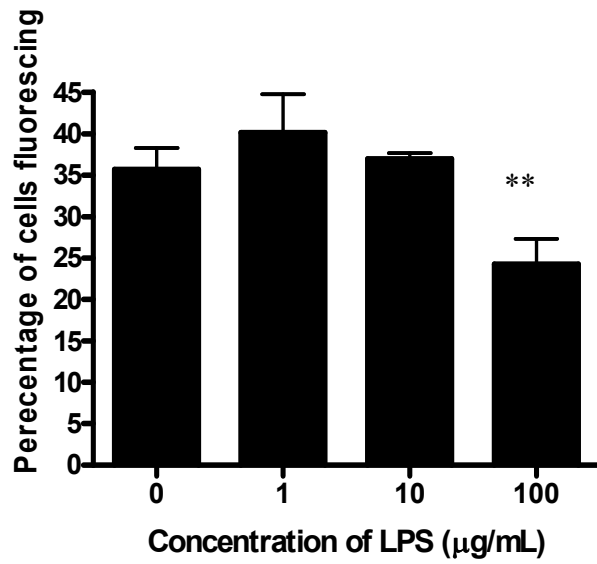

Figure 16. Percentage of apoptotic PMN (5×10^6 PMN/mL) following 20 h of incubation with varying concentrations of LPS in the absence (A) or presence (B) of FBS. Means \pm SEM of five individual experiments. Values did not differ from unstimulated PMN ($P > 0.05$)

A



B

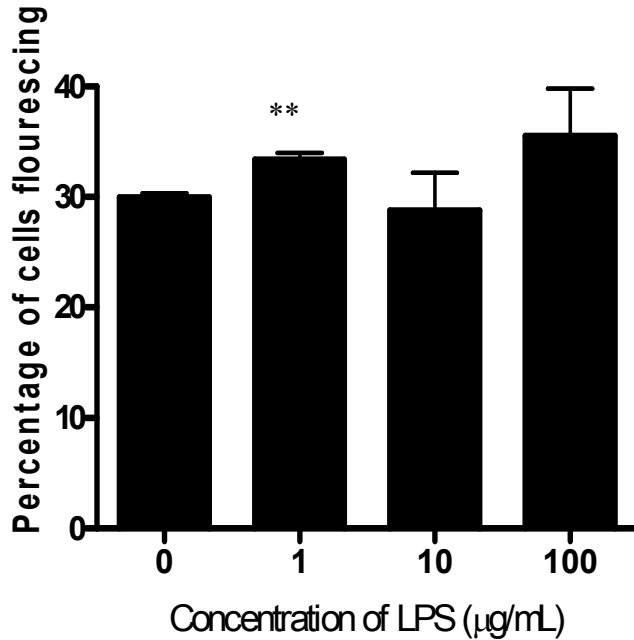

Figure 17. LPS (100 µg/mL) decreased percentage of PMN expressing mCD14 when compared to media control (A) and increased when stimulated with 1 µg/mL in the presence of FBS (B). Means ± SEM of six individual experiments. Values differ from unstimulated PMN (**P<0.001).

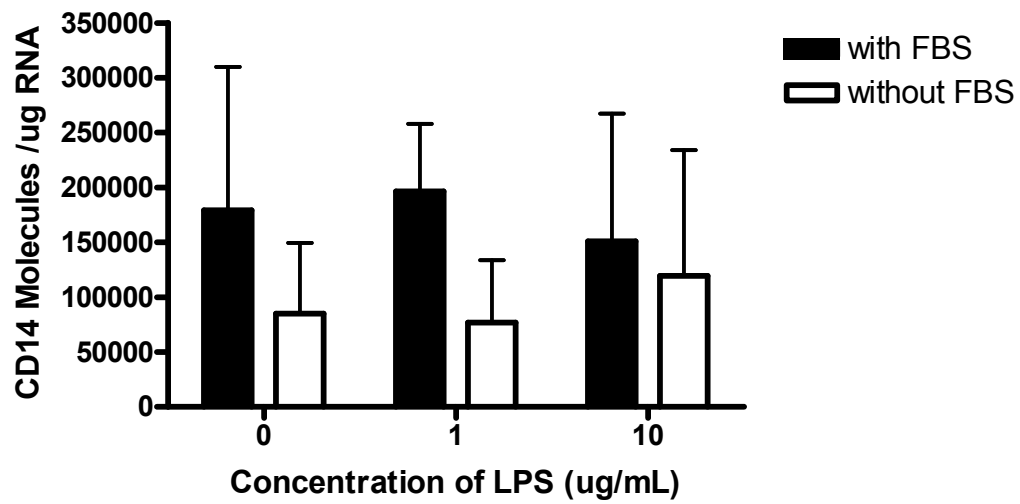

Figure 18. Expression of CD14 mRNA in PMN in response to LPS in the presence or absence of FBS. After 1 h, cells were collected and total RNA was extracted and subjected to quantitative real time PCR. Means \pm SEM of four individual experiments. Values did not differ from unstimulated PMN ($P > 0.05$)

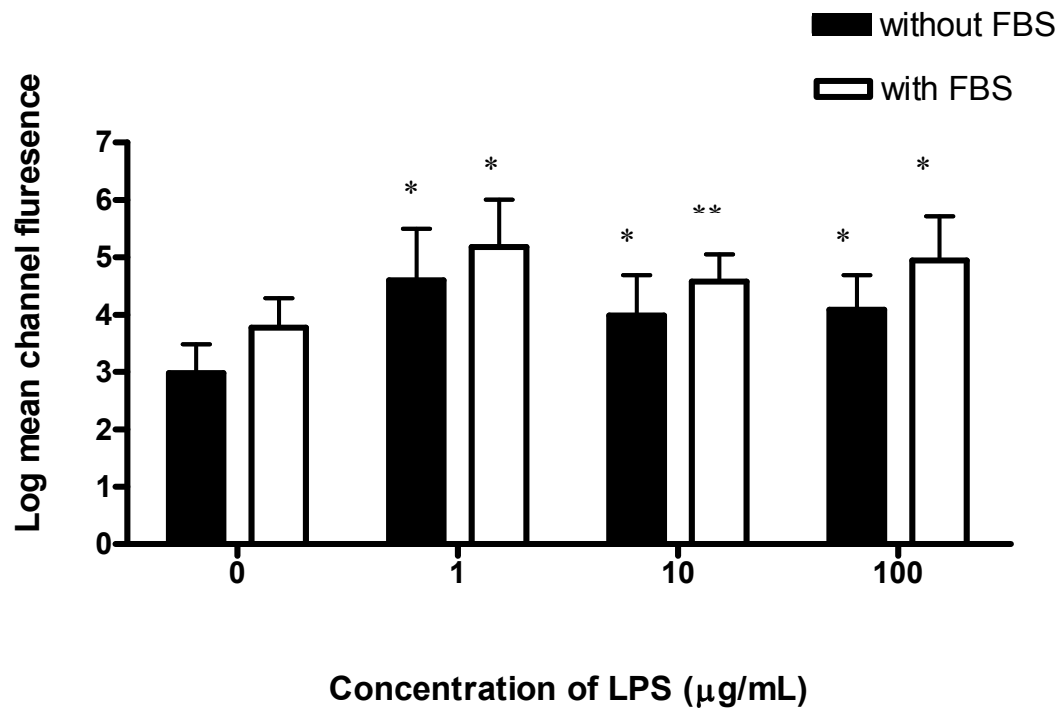
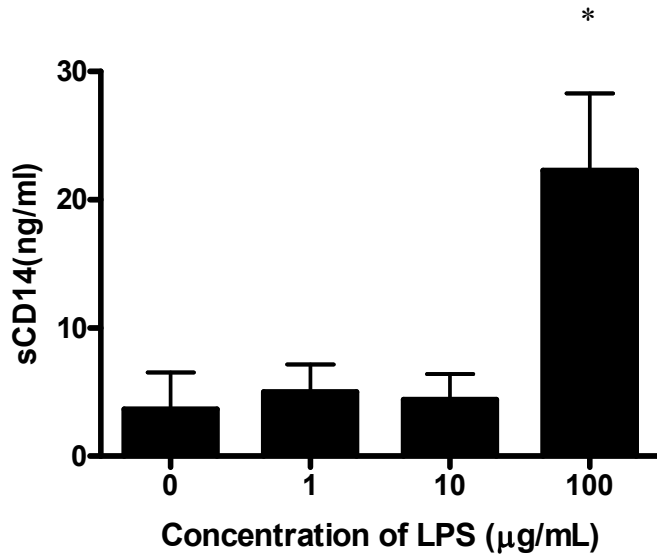

Figure 19. LPS treatment resulted in enhanced CD18 expression on PMN in either the presence or absence of 5% FBS. Values differ from media only (*P<0.05, **P<0.001). Means ± SEM of six individual experiments

A



B

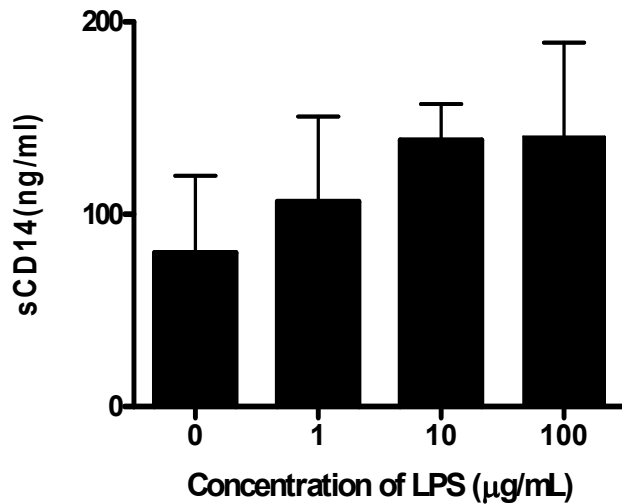
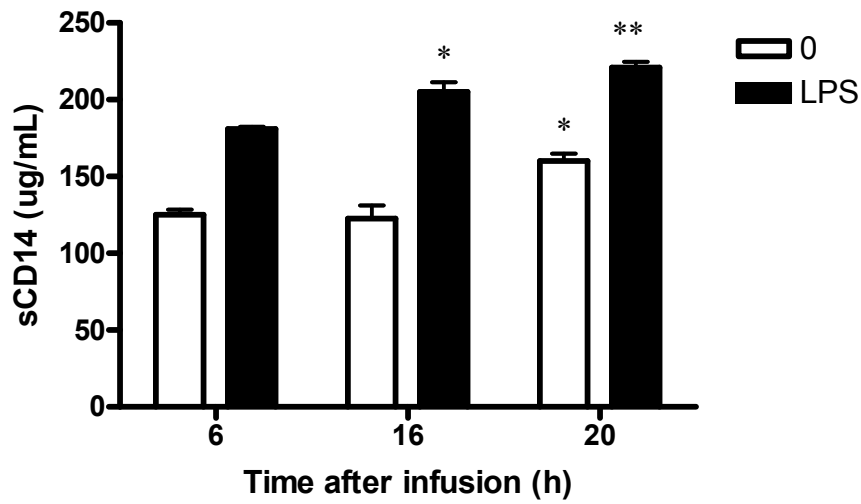

Figure 20. Release of sCD14 from PMN in the absence (A) or presence of FBS (B) after 20 h of incubation with different concentrations of LPS. Supernatants were assayed for CD14 by ELISA. In the absence of FBS, 100 $\mu\text{g/mL}$ of LPS induced release of CD14 from PMN (* $P < 0.05$). In the presence of FBS values did not differ from media only ($P > 0.05$). Means \pm SEM of least four individual experiments.



B

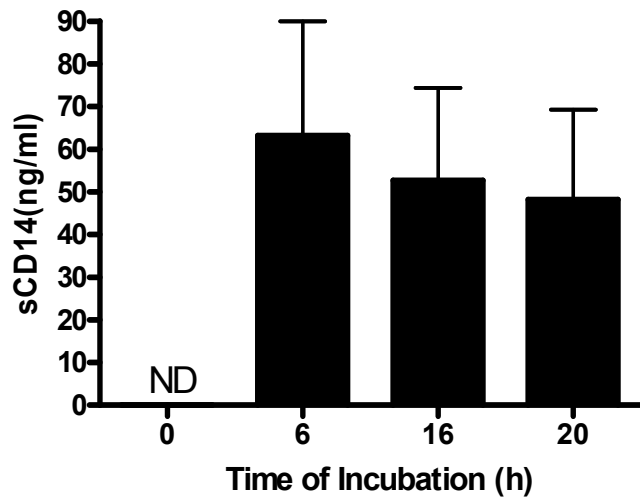

Figure 21. Concentration of sCD14 in supernatants after stimulation of PMN with 100 µg/mL of LPS in the presence (A) or absence (B) of FBS after 6, 16, 20 h of incubation. Values differ from stimulated PMN with LPS at 6 h (* $P < 0.05$, ** $P < 0.001$). Means \pm SEM of three individual experiments. ND = Non detectable.

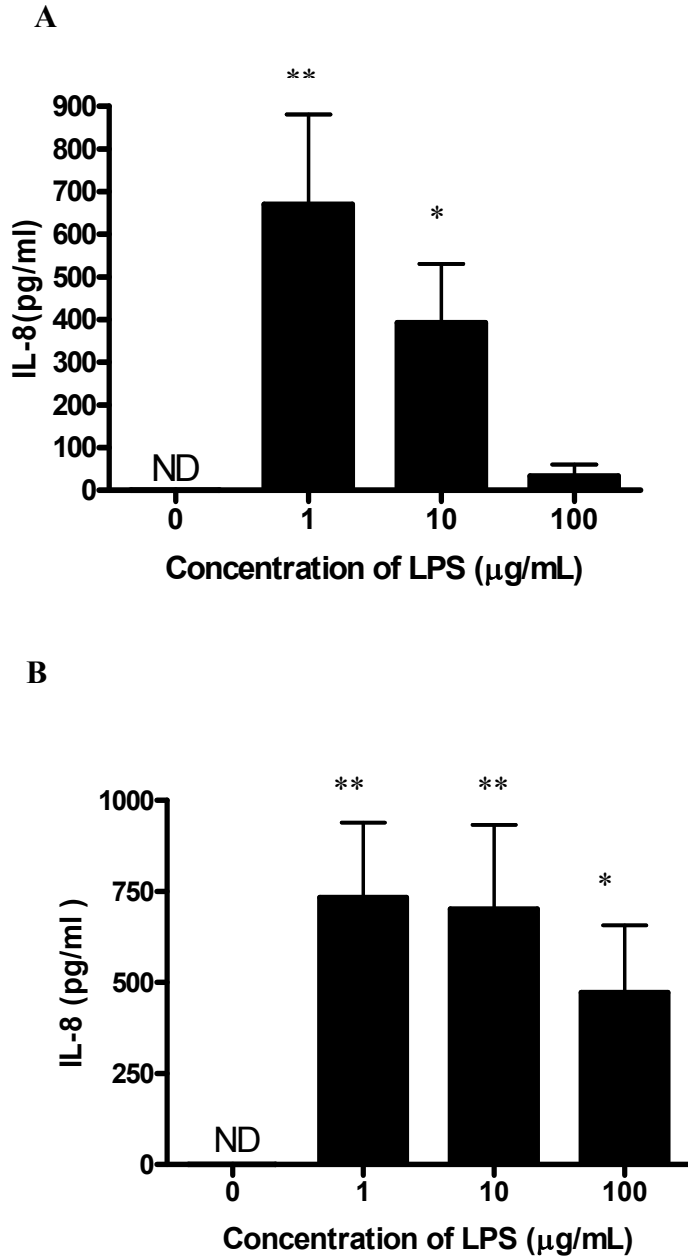
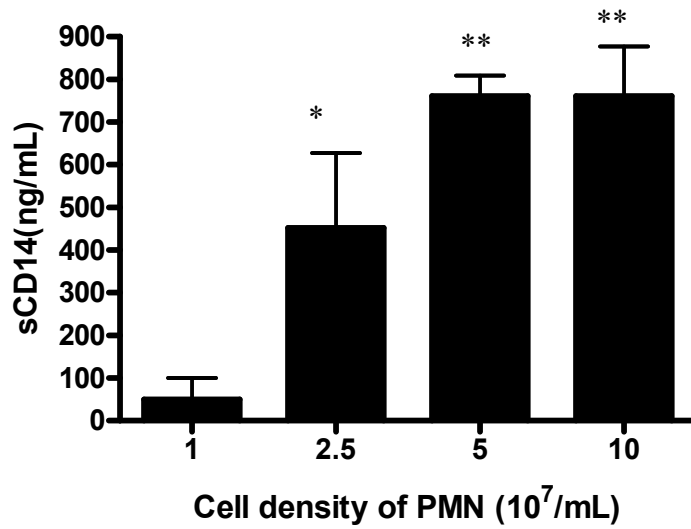

Figure 22. Release of IL-8 from PMN in the absence (A) or presence of FBS (B) after 20 h of incubation with different concentrations of LPS. Supernatants were assayed for IL-8 by ELISA. In the absence of FBS, 1 and 10 $\mu\text{g/mL}$ of LPS induced release of IL-8 from PMN. In the presence of FBS, all concentrations of LPS induced release of IL-8. Values differ from media only (* $P < 0.05$, ** $P < 0.001$). Means \pm SEM of five individual experiments. ND = Non detectable.

A



B

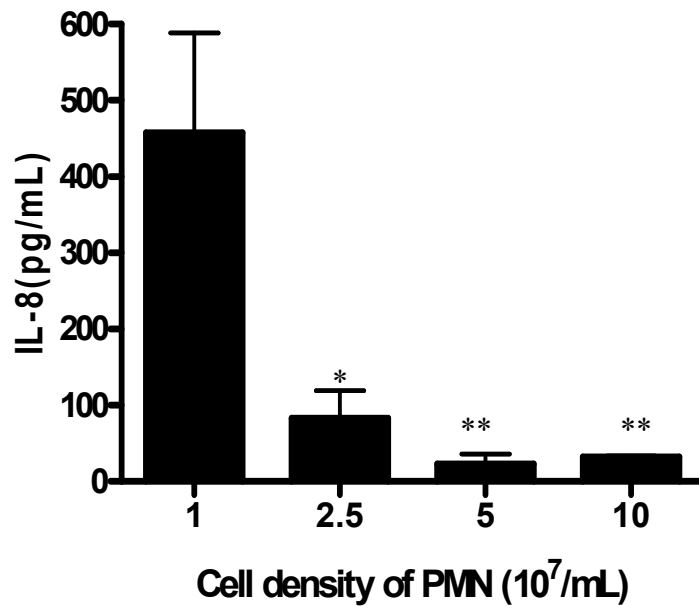
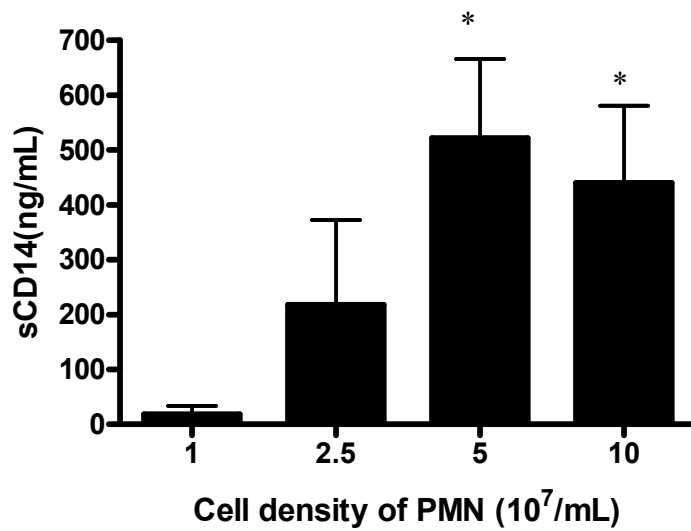

Figure 23. Effect of PMN concentration on release of sCD14 (A) and secretion of IL-8 (B) in response to 10 μ g/mL of LPS in the absence of FBS. Values differ from 1 x 10^7 PMN/mL (* P<0.05, **P<0.001). Means \pm SEM of four individual experiments.

A



B

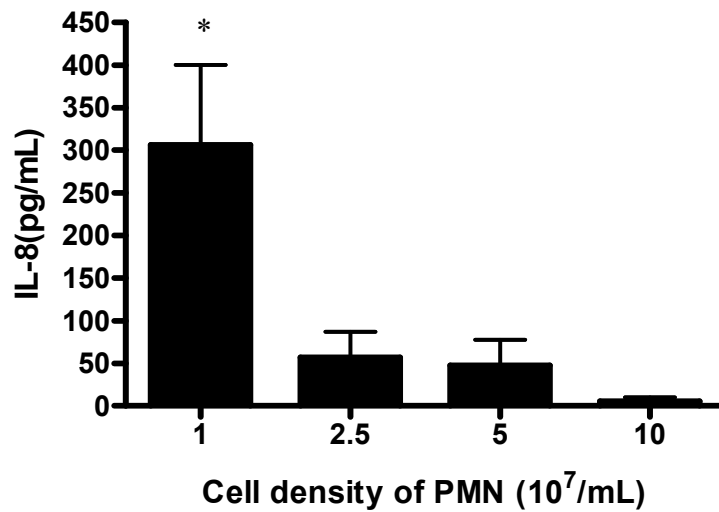
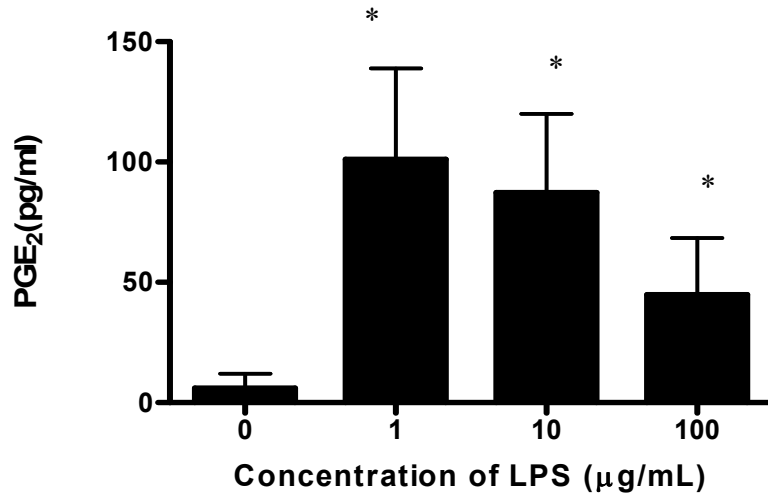
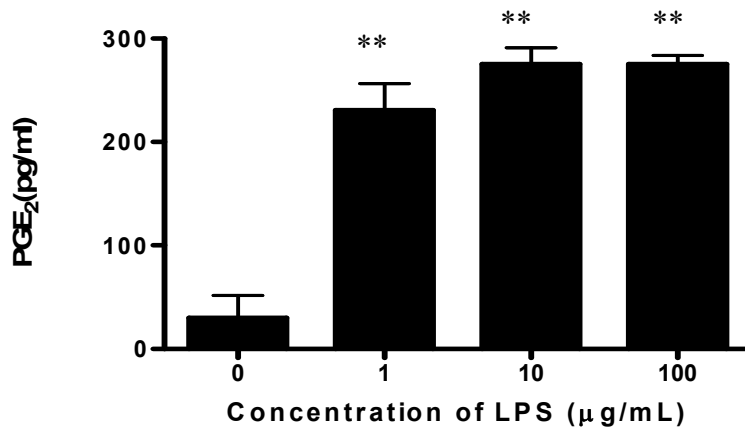

Figure 24. Effect of PMN concentration on release of sCD14 (A) and secretion of IL-8 (B) in response to 0.1 μ g/mL LPS in the absence of FBS. Values differ from 1×10^7 PMN/mL (* $P < 0.05$, ** $P < 0.001$). Means \pm SEM of four individual experiments.

A



B



C

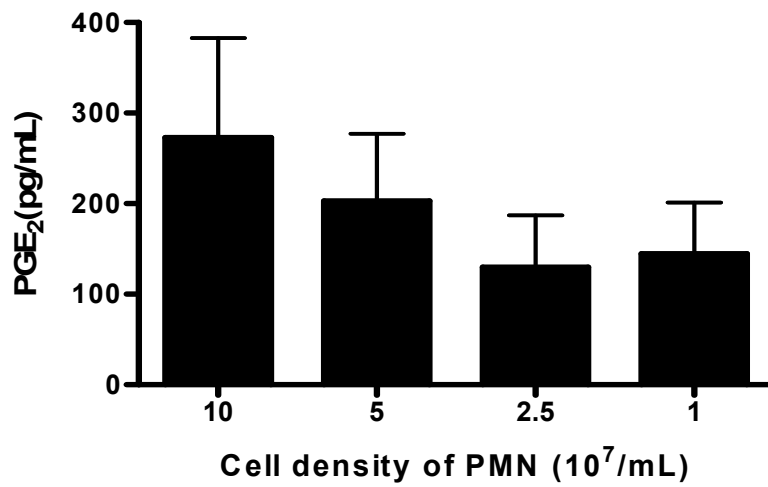
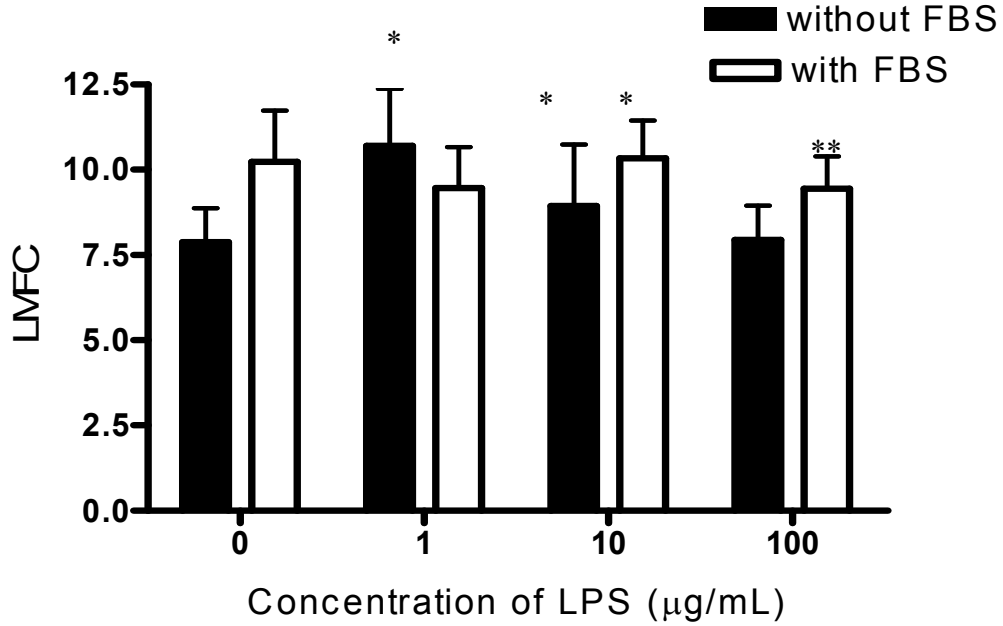

Figure 25. Release of PGE₂ from PMN (5×10^6 PMN/mL) in the absence (A) or presence (B) of FBS after 20 h of incubation with different concentrations of LPS in RPMI media. Effect of cell density on PGE₂ secretion in response to 0.1 μ g/mL of LPS in the absence of FBS (C). Cell supernatants were assayed for PGE₂. Values differ from media only (* P<0.05, ** P<0.001). Means \pm SEM of four individual experiments.

A



B

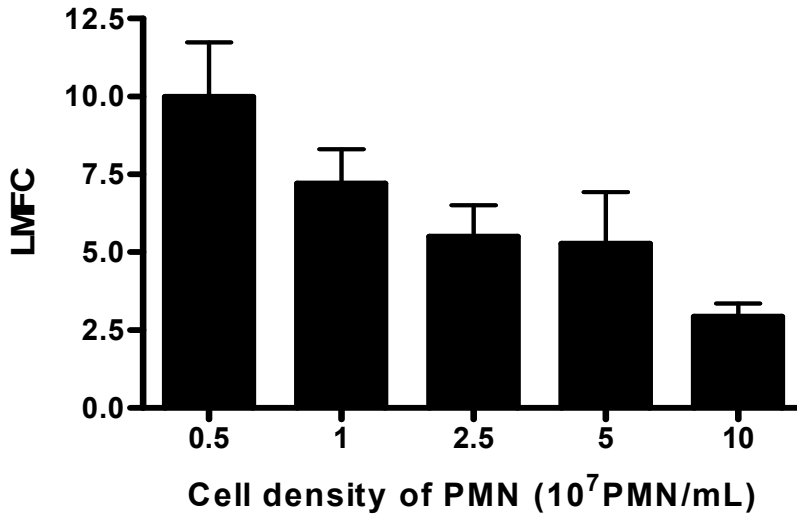

Figure 26. The expression of L-selectin on PMN (5×10^6 PMN/mL) in the absence and presence of FBS after 20 h of incubation with different concentrations of LPS (A). Effect of cell density on L-selectin expression in response to 0.1 µg/mL of LPS in the absence of FBS (B). Values differ from media only (A), and from 0.5×10^7 /mL PMN (B) (* $P < 0.05$, ** $P < 0.001$). Means \pm SEM of five individual experiments.

Chapter Five: Cytokine Production by Bovine Neutrophils Stimulated with LPS

ABSTRACT

After intramammary infection, polymorphonuclear neutrophil leukocytes (PMN) are the first cells recruited into the mammary gland. Rapid recruitment and bacterial phagocytosis and killing by PMN are the most effective defenses against establishment of bacterial infection. In addition to their phagocytic and bactericidal properties, PMN may play a key supportive role, through secretion of cytokines during the innate immune response. We sought to determine whether bovine PMN produce cytokines in response to stimulation by LPS. To investigate the effects of LPS on the expression of cytokines secreted by bovine PMN, we measured the expression of TNF- α , IL-1 β , IL-12, and IFN- γ by ELISA after stimulation with different concentrations of LPS, and secretion of IL-8 and IFN- γ after stimulation with LPS co-incubated with TNF- α , IL-1 β and IL-12. Bovine PMN were shown to secrete TNF- α , IL-1 β , IL-12, IL-8 and INF- γ in the response to LPS. The secretion of TNF- α , IL-1 β , and INF- γ increased in a dose-dependent manner, whereas IL-12 decreased with increasing concentrations of LPS. Co-incubation of LPS with either TNF- α or IL-1 β increased secretion of IL-8 when compared to LPS alone, and no effect was observed for IL-12. It was concluded that LPS stimulation can up-regulate the secretion of cytokines by bovine PMN, and that co-incubation of LPS with TNF- α or IL-1 β had an additive effect on the secretion of IL-8. These data show that bovine PMN, in addition to their phagocytic and bactericidal properties, may play a supportive role in the innate immune response to infection by Gram-negative bacteria.

INTRODUCTION

During intramammary infection PMN, the first cells recruited are attracted by chemotactic agents such as IL-8, IL-1 and leukotriene B4 released from activated endothelium and macrophages (28). In mammary quarters free from bacterial infection, macrophages are predominant cell type (35-79%), followed by PMN (3-26%), lymphocytes (10-24%) and epithelial cells (2-15%). During intramammary infection, the percentage of PMN increases and can approach 100% (116, 142, 150). Migration of PMN into tissue provides the first immunological line of defense against bacterial infection.

PMN are short-lived white blood cells that play a vital role in the inflammatory response and are considered to be differentiated effector cells capable of phagocytosis and intracellular killing. IL-1 β , IL-8, and TNF- α , contribute to the establishment of inflammation by altering vascular permeability, promoting PMN recruitment to the site of infection, and inducing hepatic synthesis of acute phase proteins that facilitate complement activation and host detection of bacterial cell wall products (56, 67). IL-12, which is produced by phagocytic cells and B-lymphocytes in response to LPS, plays a key role in the initiation of both innate and antibody-specific pro-inflammatory immunity (213). IL-12 also enhances the cytotoxic activity of natural killer (NK) cells (2, 165). IFN- γ plays a central role in controlling the host's response to bacterial and viral infection (46), because it can both enhance and suppress chemokine secretion in response to pro-inflammatory cytokines such as IL-1 β and TNF- α , modulate chemokine receptor expression, and affect diapedesis of PMN into tissue (206).

PMN and mononuclear cells play important roles in the host defense to Gram-negative infection. Most studies have focused on the immunomodulation change of bovine mononuclear cells, and only a few have been conducted on immunomodulation changes of bovine PMN. Several cytokines have been proposed to be involved in mastitis, including IL-1, IL-8, TNF- α and IL-12 (170, 193) and are responsible for modulating the physiological functions of PMN (71, 201). The purpose of this study was to determine the expression of cytokines by bovine PMN in response to LPS.

MATERIAL AND METHODS

PMN culture and activation

PMN were adjusted to 5×10^6 /mL in RPMI containing 5% FBS, and added to 96-well tissue culture plates (200 μ L/well), and incubated at 37°C in a 5% CO₂ incubator for 18 h. To study the release of INF- γ , PMN were cultured with or without 5% FBS in either media alone (control), LPS (0.1 μ g/mL), human IL-12 (Serotec, UK), LPS plus IL-12 or with different concentration of LPS (1, 10, and 100 μ g/mL). To study the release of IL-8, PMN were cultured with either media alone, human TNF- α (10 ng/mL) (Endogen), bovine IL-1 β (10 ng/mL) (Endogen), 0.1 μ g/mL of LPS plus either human TNF- α (10 ng/mL) (Endogen), bovine IL-1 β (10 ng/mL) (Endogen). After 18 h, cells and cell supernatants were separated by centrifugation (9,300 x g, 5 min, at 4°C) and cell supernatants were harvested. For the time course experiments, PMN were cultured with 0.1 μ g/mL LPS and supernatants were collected at 0, 3, 6, 9, and 18 h after centrifugation (9,300 x g, 5 min, at 4°C) for determination of INF- γ , IL-1 β , IL-12, and TNF- α . Supernatants were stored at -20°C for further processing.

Quantitation of IL-8 and IFN- γ

IL-8 and IFN- γ were determined in undiluted PMN supernatants with a commercially available human IL-8 ELISA kit (R&D Systems). Bovine IFN- γ was assayed with a commercially available EASIA kit (Biosource, Nivelles, Belgium). OD at 450 nm and a correction wavelength 550 nm were measured on a microplate reader.

Quantitation of IL-12

Flat bottom 96-well plates were coated overnight at 4°C with 4 $\mu\text{g/mL}$ of mouse anti-human IL-12 (Serotec) antibody diluted in 0.05 M sodium carbonate, pH 9.6. The plates were washed three times with 0.05% Tween-20 diluted in 50 mM TBS, pH 8.0, and blocked with 2% fish skin gelatin (Sigma) for 1 h at room temperature. The plates were washed and 100 μL of sample was added to the anti-IL-12-coated plates. Following a 2 h incubation at room temperature, the plates were washed, and 100 μL of biotin-conjugated mouse anti-bovine IL-12 (Serotec) antibody diluted to 1 $\mu\text{g/mL}$ was added to each well. The plates were incubated for 1 h at room temperature and washed. HRP-conjugated streptavidin (Sigma) was diluted 1:500 in TBS wash buffer containing 0.2% gelatin, and 100 μL of this solution was added to each well. The plates were incubated for 1 h at room temperature and washed. TMB substrate solution (Sigma) was added to each well. The reaction was stopped by the addition of 100 μL of 2M H_2SO_4 , and the absorbance was read at 450 nm on a microplate reader.

Quantitation of IL-1 β and TNF- α

Flat bottom 96-well plates were coated overnight at 4°C with 5 μ g/mL of mouse anti-bovine IL-1 β (Serotec) antibody or with 100 μ L of anti-mouse TNF- α mAb (154) diluted 1:2000 in 0.05 M sodium carbonate, pH 9.6. The plates were washed three times with 0.05% Tween 20 diluted in 50 mM TBS, pH 8.0, and blocked with 2% fish skin gelatin (Sigma) for 1 h at room temperature. The plates were washed, and 100 μ L of sample was added to the anti-IL-1 β or anti-TNF- α -coated plates. Following a 2 h incubation at room temperature, the plates were washed, and either 100 μ L of rabbit polyclonal anti-bovine IL-1 β (Serotec) antibody diluted to 1: 500 or 100 μ L of rabbit polyclonal anti-bovine TNF- α antibody diluted 1:20,000 were added. The plates were incubated for 1 h at room temperature and washed. HRP-conjugated anti-rabbit IgG (Sigma) was diluted 1: 5000 in TBS wash buffer containing 0.2% gelatin, and 100 μ L of this solution was added to each well. The plates were incubated for 30 min at room temperature and washed. TMB substrate solution (Sigma) was added to each well. The reaction was stopped by the addition of 100 μ L of 2M H₂SO₄ and the absorbance was read at 450 nm on a microplate reader.

Statistical methods

The unpaired or paired t-test (Prism version 4.0 for Windows; GraphPad Software Inc.) was used for the statistical analysis. P values below 0.05% were considered significant.

RESULTS

Secretion of IL-8 by PMN

Neither TNF- α or IL-1 β elicited an enhanced ($P > 0.05$) release of IL-8 from PMN when compared to media alone, although a slightly enhanced IL-8 release in the presence of TNF- α , and IL- β was detected (5.68 ± 2.5 , 14.3 ± 7.4 pg/mL) (Figure 27). In the presence of 0.1 μ g/mL LPS, PMN exhibited enhanced ($P < 0.05$) IL-8 release, averaging 91.4 ± 38 pg/mL. Adding LPS together with either TNF- α or IL-1 β further increased ($P < 0.05$) IL-8 release (202 ± 80 and 116.7 ± 46 pg/mL) (Figure 27).

IL-12 in the absence of 5% FBS enhanced ($P < 0.05$) INF- γ release from PMN (780.7 ± 87.8 pg/mL), but LPS or LPS plus IL-12 produced no increase when compared to control cells in the absence of FBS (Table III). No changes were observed in the presence of FBS.

Effect of different concentrations of LPS on INF- γ secretion by PMN

Unstimulated control PMN secreted INF- γ (71 ± 46 pg/mL) after 18 h of incubation, similar to INF- γ concentrations observed when incubated with either 1 or 10 μ g/mL of LPS (Figure 28A). Secretion of INF- γ increased ($P < 0.05$) (162 ± 48 pg/mL) in the presence of 100 μ g/mL of LPS. INF- γ was secreted immediately after stimulation with 0.1 μ g/mL of LPS, and then decreased ($P < 0.05$) with increased time of incubation, except at 9 h of incubation (Figure 28B).

Effect of different concentrations of LPS on IL-1 β secretion by PMN

IL-1 β increased ($P < 0.05$) with the different concentrations (1, 10 and 100 $\mu\text{g/mL}$) of LPS when compared to media control (Figure 29A). In the time course experiment, IL-1 β increased ($P < 0.05$) at 9 h, and maximal secretion occurred at 18 h after stimulation with 0.1 $\mu\text{g/mL}$ of LPS (Figure 29B).

Effect of different concentrations of LPS on IL-12 secretion by PMN

Secretion of IL-12 increased ($P < 0.05$) after incubation with either 1 or 10 $\mu\text{g/mL}$ of LPS when compared to media control (Figure 30A). The increase observed with 100 $\mu\text{g/mL}$ of LPS was not different ($P > 0.05$) from media control. The length of incubation time on release of IL-12 after stimulation with 0.1 $\mu\text{g/mL}$ of LPS had no effect on IL-12 secretion until after 18 h ($P < 0.05$) (Figure 30B).

Effect of different concentrations of LPS on TNF- α secretion by PMN

Unstimulated PMN immediately secreted TNF- α (0.75 ± 0.05 ng/mL) (Figure 31A). Secretion of TNF- α was further elevated ($P < 0.05$) in culture media containing 10 and 100 $\mu\text{g/mL}$ of LPS. The increase observed at 1 $\mu\text{g/mL}$ of LPS was not different ($P < 0.05$) from media control. The secretion of TNF- α was already elevated (1.5 ng/mL) at time 0 and further increased ($P < 0.05$) at 6 h after stimulation with 0.1 $\mu\text{g/mL}$ of LPS (Figure 31B). The highest concentration of TNF- α occurred at 18 h.

DISCUSSION

The results of this study demonstrate that circulating bovine PMN responds to LPS stimulation by secreting TNF- α , IL-1 β , IFN- γ , IL-8 and IL-12, and contributes to the innate immune response in dairy cows.

TNF- α has been reported to stimulate IL-8 release by human PMN (212), whereas in the present study TNF- α alone had no effect on IL-8 secretion by bovine PMN (Figure 27). TNF- α increases phagocytosis, degranulation and oxidative burst activity of bovine PMN and expression of endothelial cell adhesion molecules by promoting PMN adherence to vascular endothelium. One study reported that bovine periperal PMN were capable of releasing TNF- α following stimulation with bacterial LPS (149).

The results of the present study showed that secretion of TNF- α , IL-1 β , IFN- γ , IL-8 and IL-12 by bovine PMN was induced by LPS. IL-1 β can stimulate T-helper cells and B-cells to synthesize immunoglobulin, and also promotes the adhesion of PMN, monocytes, T-cells, and B-cells to endothelium by enhancing the expression of adhesion molecules such as the intracellular adhesion molecule, endothelial leukocyte adhesion molecule and the proliferation and activation of NK cells as well (116). Secretion of TNF- α , IL-1 β and IL-12 peaked at 18 h (Figure 28, Figure 29, Figure 30). In contrast, release of IL-12 showed a dose-dependent decrease (Figure 30 A). Several studies (3, 170, 171) reported that in the bovine mammary gland, mRNAs for IL-1 β , IL-6, TNF- α , IL-8 and IL-12 were detected in PMN from glands experimentally challenged with *S. aureus* α -toxin and *S. aureus*.

IL-12 was the most efficient stimulus after 18 h of culture in up-regulating INF- γ

production (Table III). IL-12 is chemotactic for human PMN, and also activates IL-8 and TNF- α synthesis (1). The biological activities of IL-12 include enhancement of cytotoxic T cell and lymphokine-activated killer cell generation and activation, increased natural killer cell cytotoxicity, induction of activated T-cell and NK-cell proliferation, induction of INF- γ production by NK cells and T cells, and inhibition of IgE synthesis by IL-4 stimulated lymphocytes via INF- γ dependent and independent mechanisms (76, 104).

The ability of PMN to produce INF- γ points to a new role for bovine PMN during the innate immune response. Human PMN contain a small store of INF- γ and this store is rapidly secreted upon stimulation by degranulating agents such as formyl peptides. After a few hours of stimulation, PMN synthesizes INF- γ (64). This is consistent with our study that bovine PMN secrete INF- γ immediately after LPS stimulation.

LBP is known as a lipid transfer protein that presents LPS to CD14 receptors (82). TLR4, TLR2, and CD14 are important for mediating immune cell responses to LPS (161, 227). PMN express low levels of TLR4, and moderate levels of TLR2 and CD14 (109). Several studies (91, 134, 159) have described CD14-independent LPS effects. Activation of TLR4-dependent signal transduction pathways appears to require participation of CD14 (39,113). TLR2 is CD14-independent LPS receptors and does not require CD14 for initiation of intracellular pathways, and the role of TLR2 in this response remains unclear (208). Cell-surface CD11b/CD18 is a receptor for LPS. When LPS activation is mediated by CD11b/CD18, serum is not required for transmembrane signal transduction (95).

Several studies showed that human PMN produced TNF- α , IL-12 and IL-8, after stimulation with microbial products such as bacterial LPS, *Toxoplasma gondii* and

Candida albicans (30, 33, 34). While PMN normally undergo rapid apoptosis during culture, several inflammatory cytokine (e.g, IL-1 β , TNF- α , IL-6, G-CSF, GM-CSF) prolong their life span, suggesting that PMN may be longer-lived during infections than previously believed (13, 42).

To date, no one has demonstrated cytokine expression in bovine circulating PMN in response to LPS. The findings in this study that PMN are capable of producing several major inflammatory cytokines in response to LPS, suggests that PMN may be important in directing early cell trafficking and cytokine-producing activities during infection by microbial pathogens.

Table III. INF- γ secretion by bovine PMN after incubation (18 h, 37°C) with LPS (0.1 $\mu\text{g}/\text{mL}$) and human IL-12 (5 ng/mL) in the presence and absence of 5% FBS (n=5). *Significantly different ($P < 0.05$) from media control.

Stimuli	INF-γ (pg/ml) without FBS	INF-γ (pg/ml) with FBS
None	548.3 \pm 49.7	425 \pm 83.4
LPS	487.1 \pm 313.4	291.4 \pm 91.9
IL-12	780.7 \pm 87.8 (*)	450.4 \pm 58
LPS+IL-12	597.2 \pm 85	425.9 \pm 83.4

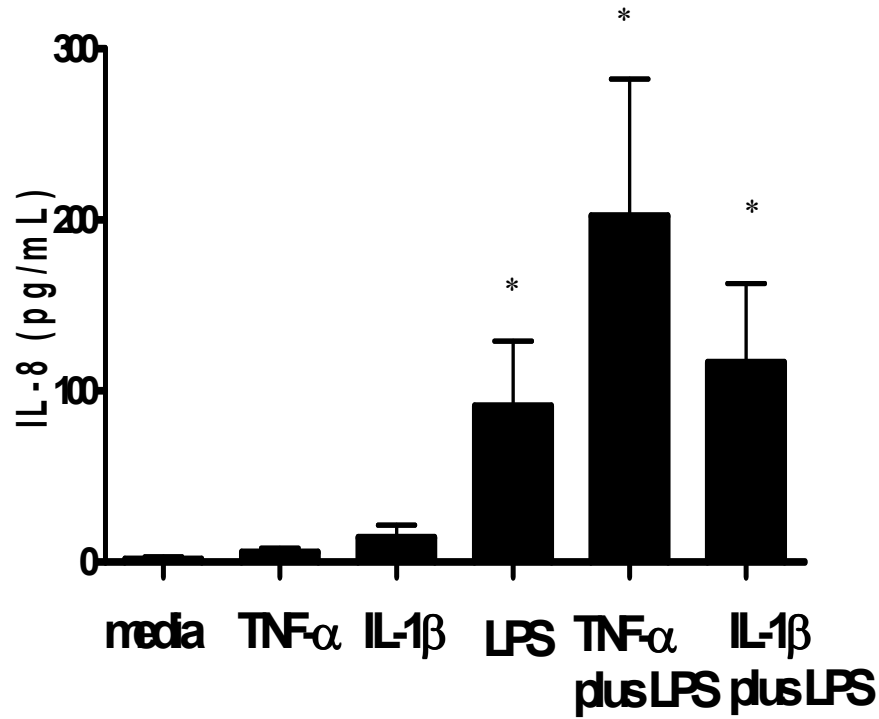
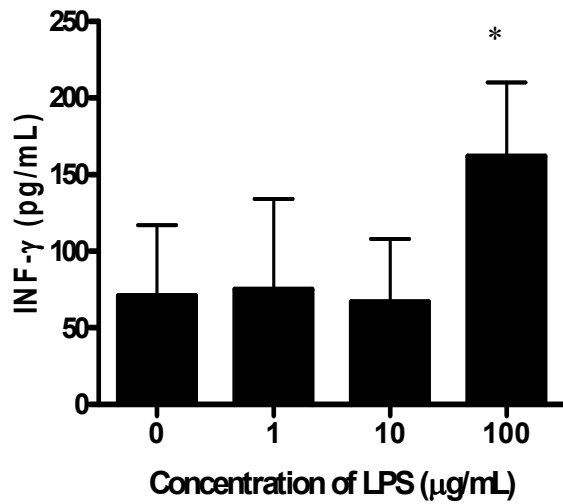

Figure 27. The effect of different stimuli on IL-8 release from bovine PMN (4×10^6 PMN/mL). PMN were incubated for 18 h at 37°C with RPMI, hTNF- α (10 ng/mL), bIL-1 β (10 ng/mL), LPS (0.1 ng/mL), hTNF- α (10 ng/mL) + LPS (0.1 $\mu\text{g/mL}$), bIL-1 β (10 ng/mL)+ LPS (0.1 $\mu\text{g/mL}$). Results are expressed as means with S.E.M. (n=5). *Significantly different ($P < 0.05$) from media control.

A



B

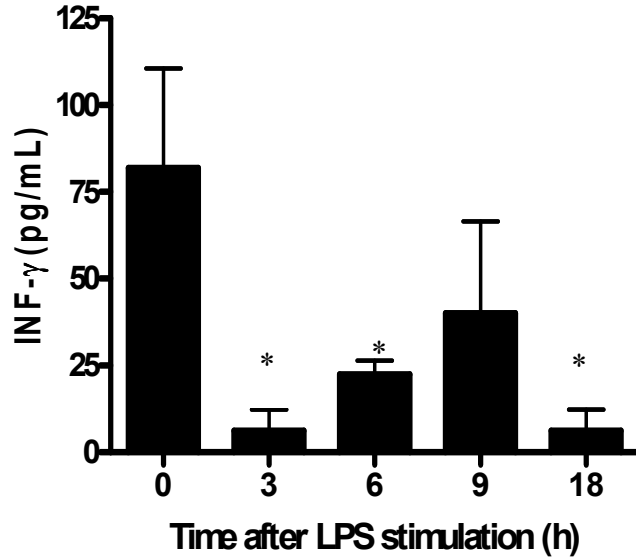

Figure 28. Concentration of IFN- γ in supernatants after incubation (18 h, 37°C) of PMN with LPS. A) PMN were plated at 5×10^5 cells/well in 96 well plates and were stimulated with different concentrations of LPS (n=10). *Significantly different (P<0.05) from media control. B) Time course of IFN- γ production after stimulation with 0.1 μg of LPS (n=3). Results are expressed as means with S.E.M. *Significantly different (P<0.05) from PMN supernatant collected immediately after LPS stimulation.

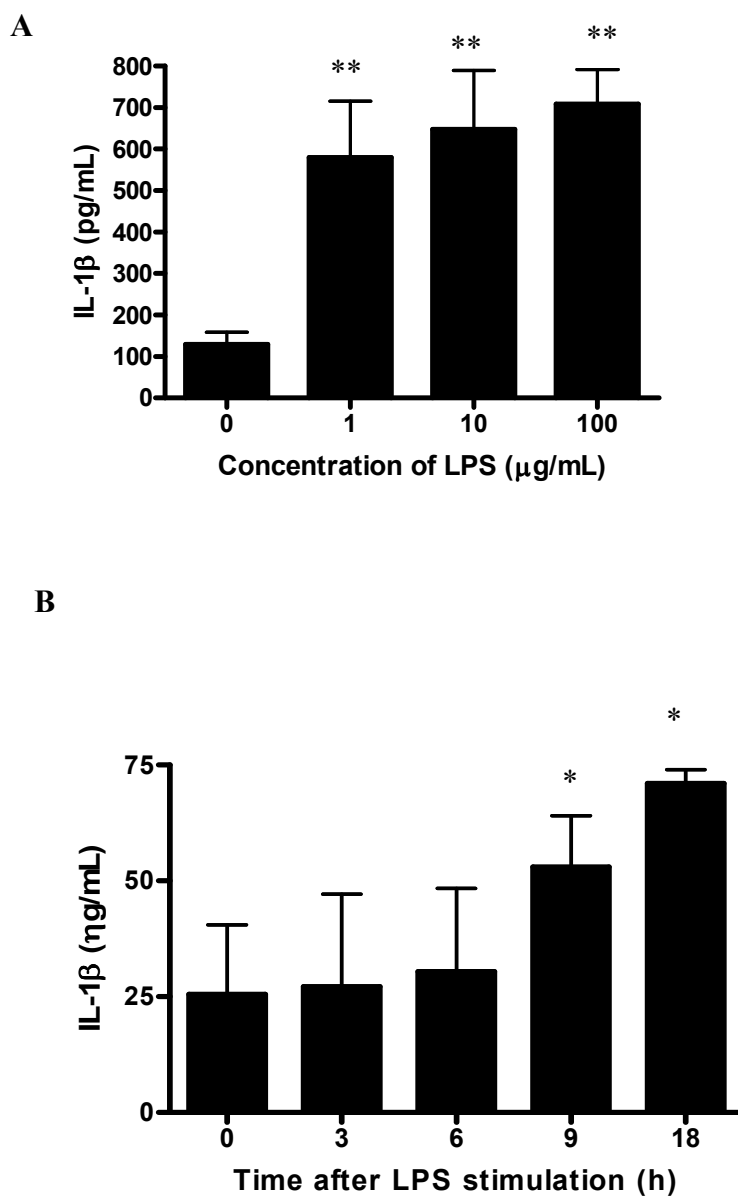

Figure 29. Concentration of IL-1 β in supernatants after incubation (18 h, 37°C) of PMN with LPS in the absence of presence of 5% FBS. A) PMN were plated at 5×10^5 cells/well in 96 well plates and were stimulated with different concentrations of LPS (n=5). *Significantly different (P<0.05) from media control. B) Time course of IL-1 β production after stimulation of 0.1 μg LPS (n=3). Significantly different (P<0.05) from PMN supernatant collected immediately after LPS stimulation. Results are expressed as means with S.E.M.

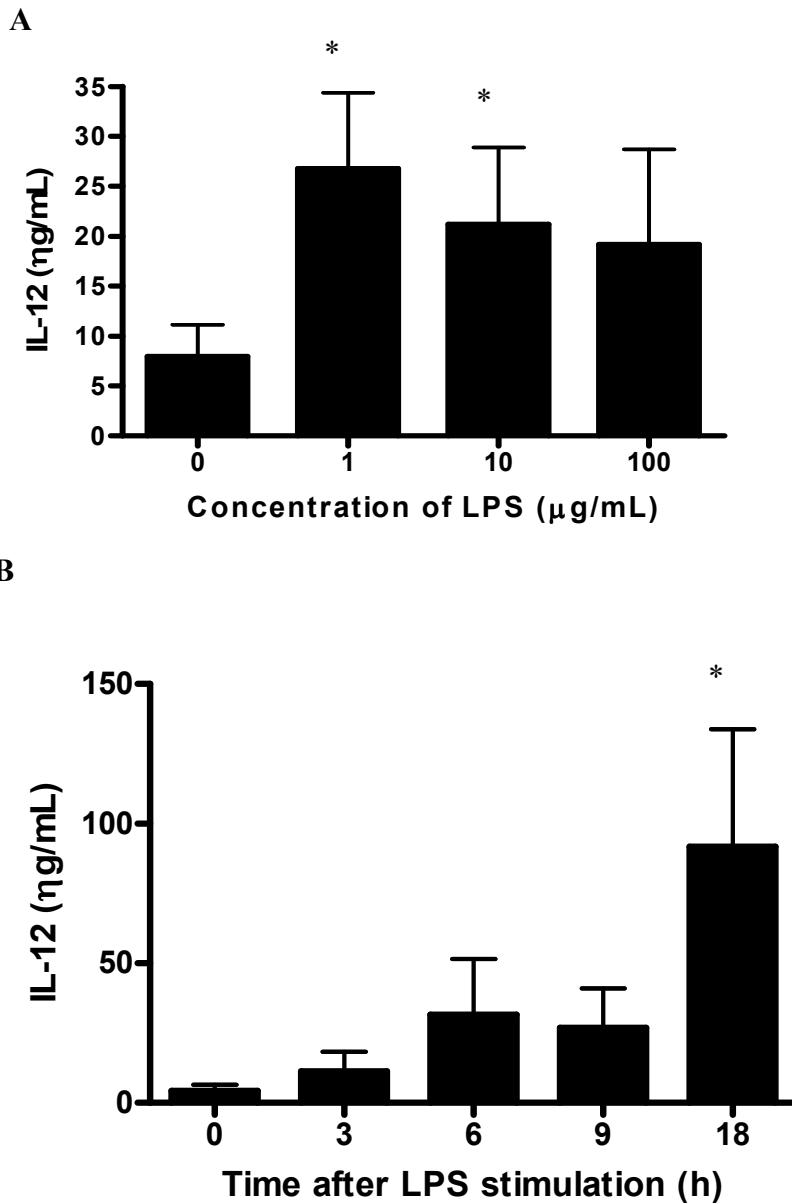
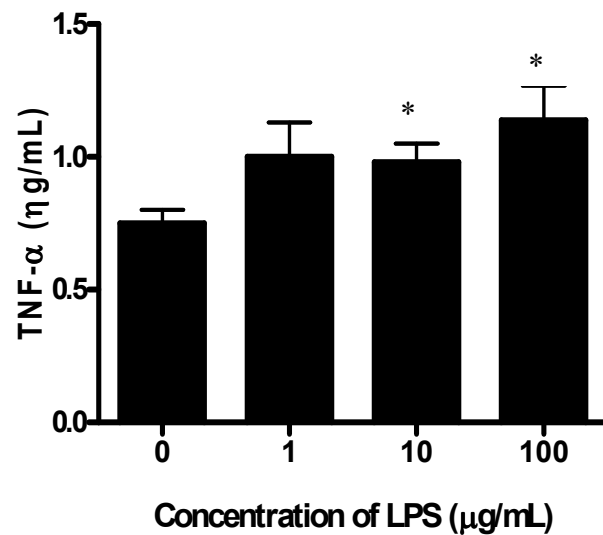

Figure 30. Concentration of IL-12 in supernatants after incubation (18 h, 37°C) of PMN with LPS. A) PMN were plated at 5×10^5 cells/well in 96 well plates and were stimulated with different concentrations of LPS (n=5). *Significantly different ($P < 0.05$) from media control. B) Time course of IL-12 production after stimulation with 0.1 μg LPS (n=3). *Significantly different ($P < 0.05$) from PMN supernatant collected immediately after LPS stimulation. Results are expressed as means with S.E.M.

A



B

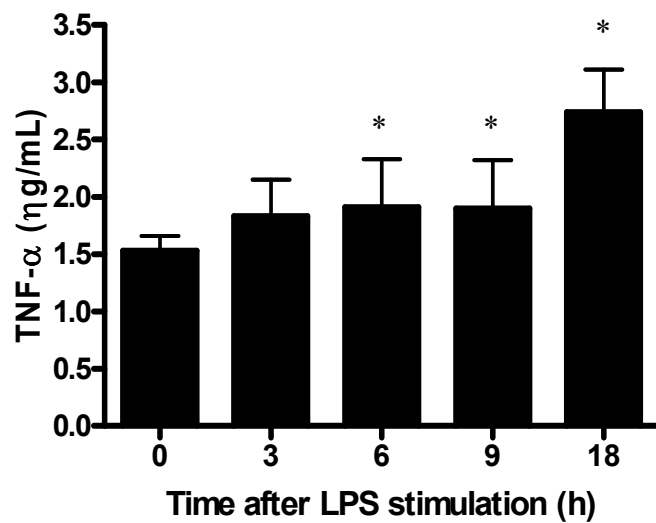

Figure 31. Concentration of TNF- α in supernatants after incubation (18 h, 37°C) of PMN with LPS. A) PMN were plated at 5×10^5 cells/ well in 96 well plates and were stimulated with different concentrations of LPS (n=5). *Significantly different ($P < 0.05$) from media control B) Time course of TNF- α production after stimulation with 0.1 μg LPS (n=3). *Significantly different ($P < 0.05$) from PMN supernatant collected immediately after LPS stimulation. Results are expressed as means with S.E.M.

Chapter Seven: General Discussion

Mastitis is defined as an inflammatory reaction within the mammary gland caused by invading bacteria through the teat canal located at the teat end of the mammary gland. Mastitis results in decreased milk production, increased veterinary costs, and culling and death of animals. Sepsis is associated with excessive activation of a number of host mediator systems, including cytokines, leukocytes, and the vascular endothelium, each of which can contribute to the development of tissue injury (251).

Binding to CD14 is considered to be a common pathway for induction of the innate immune response to a variety of microbial pathogens. Gram-negative bacteria can bind to m- and sCD14 in the presence of serum, which indicates that LPS incorporated into the membrane of Gram-negative bacteria can interact with CD14 (29, 220). CD14 on human monocytes and macrophages exists as two soluble forms in normal plasma (59). This is in agreement with our study (Chapter 2) that sCD14 in bovine milk and plasma exists as two soluble forms of 53 and 58 kDa. Varying degrees of glycosylation contributes to the heterogeneity of the sCD14 molecule (202). Gram-negative or Gram-positive bacteria are powerful stimuli of cytokine production, which causes sepsis (145). In our study (Chapter 2), LPS-induced release of TNF- α by isolated monocytes was reduced by anti-rbosCD14 mAb. The inhibitory effect of anti-rbosCD14 mAb on the secretion of TNF- α by LPS-stimulated monocytes can be due to impaired binding of these stimuli to CD14 or decreased activation of monocytes via CD14. Anti-CD14 mAb administered after injection of LPS, protected rabbits from renal and pulmonary injury, and prevented hypotension (187). Blocking of the CD14 receptor by using mAbs will inhibit the inflammatory response to LPS and may be beneficial in severe sepsis.

A number of biopharmaceuticals, including vaccines and therapeutic proteins, have been expressed in plants (132, 207), the primary motivation being reduced cost therapeutics in a plant system. The protective effect of rbosCD14 produced in a baculovirus of producing expression system was previously demonstrated in a mouse model and in lactating cows (117, 118, 119). In the present study (Chapter 3), the plant-derived rbosCD14 was shown to be a biologically active protein, possessing characteristics similar to rbosCD14: LPS induced apoptosis, caspase activity, and IL-8 production in bovine endothelial cells. PrbosCD14 sensitized the mammary gland to LPS, increasing the number of milk SCC, and showed a protective effect when tested in a bovine mastitis model. Taking into account the previously reported therapeutic effect of sCD14 against pathogenesis of coliform mastitis, expression of CD14 in plants and purification of plant-produced protein was aimed at reducing the cost of production of recombinant CD14 for preventive administration to lactating dairy cows.

PMN are important cells in the first line of defense against bacterial invasion of the bovine mammary gland. The increase in sCD14 was suggested to be associated with the accumulation of PMN at inflammatory sites (37, 117). Circulating PMN exhibit low mCD14 expression due to its shedding from the cell surfaces of stimulated PMN from patients with acute respiratory distress syndrome (157). These studies are in agreement with our study (Chapter 4) that LPS causes a decrease in the percentage of PMN expressing mCD14, resulting in an increase of sCD14 at the highest concentration of LPS in the absence of FBS. sCD14 found in human serum has been attributed to the shedding of mCD14 from monocytes, macrophage, and PMN (59). In our study (Chapter 4), the release of sCD14 from PMN caused down-regulation of IL-8 secretion from PMN in

response to LPS. Further, the increase of sCD14 with increasing cell densities of PMN in response to LPS was also parallel with the decrease of IL-8. It was reported that production of IL-8 was inhibited via CD14 cleavage by human leukocytes elastase, which might be another mechanism for the down-regulatory cascade of inflammation (146). *Burkholderia cepacia* induced IL-8 synthesis in human lung epithelial cells in a CD14 and mitogen activated protein kinase dependent manner (169).

Several studies showed that human PMN produced TNF- α , IL-12 and IL-8, after stimulation with microbial products such as bacterial LPS, *Toxoplasma gondii* and *Candida albicans* (30, 33, 34). In our study (Chapter 5), we demonstrated for the first time that, bovine PMN produced TNF- α , IL- β , IL-8, INF- γ , and IL-12 in response to LPS. In addition, IL-12 was the most efficient stimulus in up-regulating INF- γ production. While PMN normally undergo rapid apoptosis during culture, several inflammatory cytokines (e.g, TNF- α , IL-1 β , IL-8, INF- γ , IL-12, G-CSF, and GM-CSF) prolong their life span, suggesting that PMN may be longer-lived during infections than previously believed (23, 42).

Chapter Six: Conclusions:

Conclusions from the chapter 'The Production and Characterization of Anti-bovineCD14 Monoclonal Antibodies' are:

1. Anti-rbosCD14 mAb recognized a 53 and 58 kDa sCD14 in milk and blood, and a 47 kDa mCD14 in macrophages and monocytes by Western blotting analysis.
2. The anti-rbosCD14 mAb bound with mCD14 on the surface of mouse macrophages suggest that bovine CD14 has cross-reacted with mouse macrophages but not with macrophage from horse and pig.
3. An increase of sCD14 in milk was detected by ELISA between 8 to 48 h after intramammary injection of LPS.
4. Anti-rbosCD14 to mCD14 on macrophage, reduced secretion of TNF- α from macrophage after stimulation with LPS, and will be useful in studying the interrelationship between CD14 and LPS during mastitis.

Conclusions from the chapter 'Expression of a Functional Bovine CD14 Receptor in Plants' are:

1. sCD14 was incorporated into potato virus x (PVX). Bovine sCD14 was expressed in plants and purified. sCD14 was identified on Western blotting analysis and ELISA. It was designated as plant-derived sCD14 (prbosCD14).
2. Plant-derived sCD14 caused apoptosis, IL-8 producton and caspase acticity in cultured endothelial cells.
3. After intramammary injection with 0.3 μ g of LPS plus prbosCD14, milk SCC increased, and numbers of *E. coli* and clinical symptoms were reduced.

Conclusions from the chapter ‘Shedding of sCD14 by Bovine PMN Following Activation with LPS Results in Down-Regulation of IL-8’ are:

1. CD14 comes the shedding of mCD14 on the surface of PMN.
2. Release of sCD14 by PMN reduced the secretion of IL-8. The release of sCD14 from PMN caused down-regulation of IL-8 secretion from PMN (Figure 32).

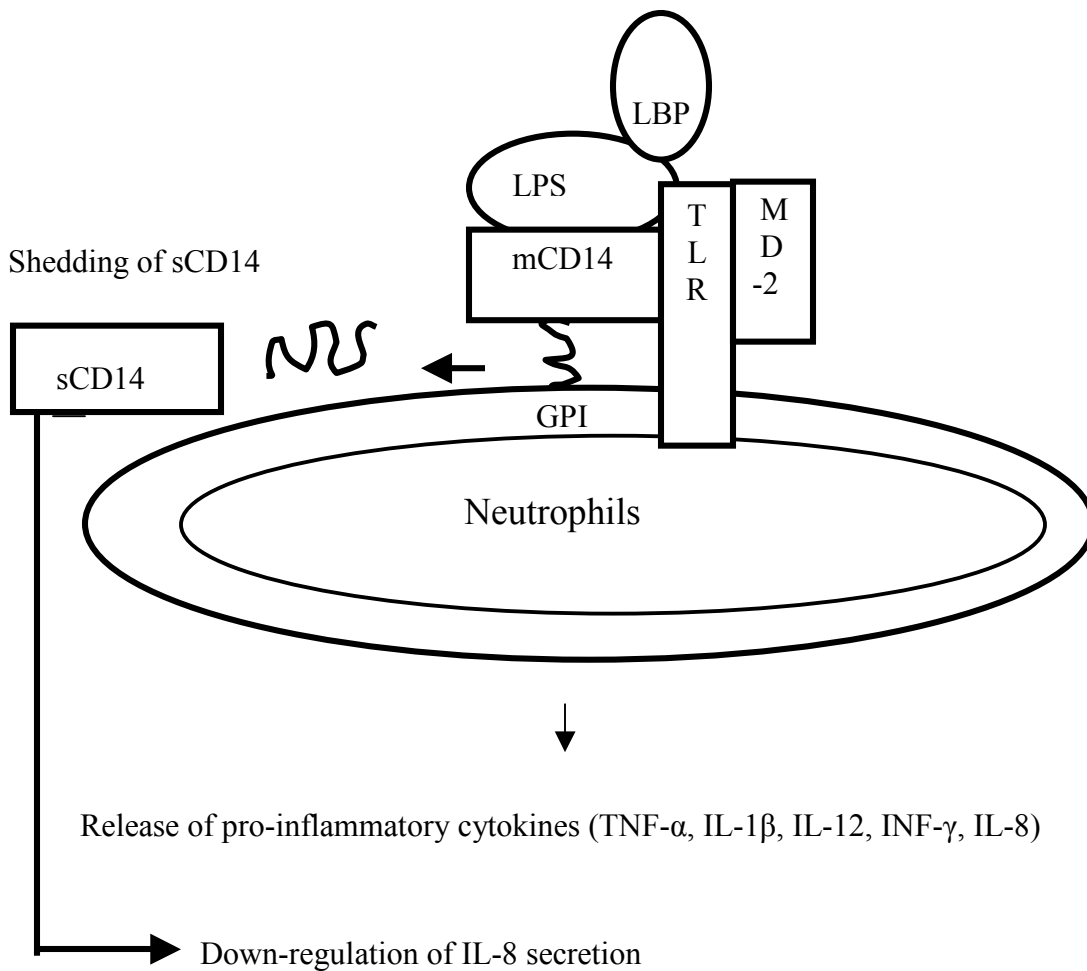

Figure 32. Schematic drawing of the objectives of this thesis. Binding of LPS by LBP/mCD14 on PMN leads to the shedding of sCD14 by losing GPI linker from mCD14, and then the sCD14 results in the down-regulation of IL-8.

Conclusions from the chapter 'Cytokine Production by Bovine Neutrophil Stimulated with LPS' are:

Adding LPS together with either TNF- α or IL-1 β increased IL-8 release compared to LPS only. IL-12 in the absence of FBS enhanced INF- γ release from PMN.

Literature Cited

1. Al-Mohanna F, Saleh S, Parhar RS. 2002. IL-12 dependent nuclear factor-kappa B activation leads to de novo synthesis and release of IL-8 and TNF- α in human neutrophils. *J Leukoc Biol.* 72:995-1002.
2. Allavena P, Paganin C, Zhou D, Sozzani S, Mantovani A. 1994. Interleukin-12 is chemotactic for NK cells and stimulates their interaction with vascular endothelium. *Blood.* 84:2261-2268.
3. Alluwaimi AM, Leutenegger CM, Farver TB, Rossitto PV, Smith WL and Cullor JS. 2003. The cytokine markers in *staphylococcus aureus* mastitis of bovine mammary gland. *J Vet Med.* 50:105-111.
4. Anderson KL, Smith AR, Gustafsson BK, Spahr SL, and Whitmore HL. 1982. Diagnosis and treatment of acute mastitis in a large dairy herd. *J Am Vet Med Assoc.* 181:690-693.
5. Anri A. 1989. Detection of endotoxin in affected milk from cows with coliform mastitis. *Nippon Juigaku Zasshi.* 51:847-848.
6. Antal-Szalmas P, Van Strijp JAG, Weersink AJL, Verhoef J, Van Kessel KPM. 1997. Quantitation of surface CD14 on human monocytes and neutrophils. *Leukoc J Leukoc Biol.* 61:721-728.
7. Ariti M, Zhou J, Dorio R, Rong G, Goyert S, Kim K. 1993. Endotoxin-mediated endothelial cell injury and activation: role of soluble CD14. *Infect. Immun.* 61:3149-3156.
8. Baggiolini M. 1998. Chemokines and leukocytes traffic. *Nature.* 392:565-568.
9. Baggiolini M, Moser B, Clark-Lewis I. 1994. Interleukin-8 and related chemotactic cytokines. The Giles Filley Lecture. *Chest.* 105:95S-98S.
10. Bainton DF, Ulliyot JL, Farquhar MG. 1971. The development of neutrophilic polymorphonuclear leukocytes in human bone marrow. *Exp Med.* 1:907-934.
11. Banks KL, Michaels FH. 1985. Stimulaton and killing of bovine mononuclear leukocytes by bacterial lipopolysaccharide (endotoxin). *Am Vet Res.* 4:1568-1572.
12. Bannerman DD, Sathyamoorthy M, Goldblum SE. 1998. Bacterial lipopolysaccharide distrupts endothelial monolayer integrity and survival signaling events through caspase cleavage of adherens junction proteins. *J Biol Chem.* 25:35371-35380.

13. Bannerman DD, Tupper JC, Kelly JD, Winn RK, Harlan JM. 2002. The Fas-associated death domain protein suppresses activation of NF-kappa B by LPS and IL-1 beta. *J Clin Invest.* 109:419-425.
14. Bannerman DD, Paape MJ, Hare WR, and Sohn EJ. 2003. Increased levels of LPS-binding protein in bovine blood and milk following bacterial lipopolysaccharide challenge. *J Dairy Sci.* 86:3128-3137.
15. Bannerman DD, Paape MJ, Goff JP, Kimura K, Lippolis JD, Hope JC. 2004. Innate immune response to intramammary infection with *Serratia marcescens* and *Streptococcus uberis*. *Vet Res.* 35:681-700.
16. Bannerman DD, Paape MJ, Lee JW, Zhao X, Hope JC, Rainard P. 2004. *Escherichia coli* and *Staphylococcus aureus* elicit differential innate immune responses following intramammary infection. *Clin Diagn Lab Immunol.* 11:463-472.
17. Barber MR, Yang TJ. 1998. Chemotactic activities in nonmastitic and mastitic mammary secretions: presence of interleukins-8 in mastitic but not nonmastitic secretions. *Clin Diagn Lab Immunol.* 5:82-86.
18. Bazil V, Horeji V, Baudays M, Kristofova H, Strominger J, Kostka W, Hilgert I. 1986. Biochemical characterization of a soluble form of the 53-kDa monocytes surface antigen. *Eur J Immunol.* 16:1583-1589.
19. Bazzoni F, Giovedi S, Kiefer MC, Cassatella MA. 1999. Analysis of the Bak protein expression in human polymorphonuclear neutrophils. *Int J Clin Lab Res.* 29:41-45.
20. Berczi I. 1998. Neurohormonal host defense in endotoxin shock. *Ann N Y Acad Sci.* 840:787-802.
21. Blondin C, Le Dur A, Cholley B, Caroff M, Haeffner-Cavaillon N. 1997. Lipopolysaccharide complexed with soluble CD14 binds to normal human monocytes. *Eur J Immunol.* 27:3303-3309.
22. Boudjellab N, Chan-Tang HS, Zhao X. 2000. Bovine interleukin-1 expression by cultured mammary epithelial cells (MAC-T) and its involvement in the release of MAC-T derived interleukin-8. *Comp Biochem Physiol A Mol Integr Physiol.* 27:191-199.
23. Brach MA, deVos S, Gruss HJ, Herrmann F. 1992. Prolongation of survival of human polymorphonuclear neutrophils by granulocyte-macrophage colony-stimulating factor is caused by inhibition of programmed cell death. *Blood.* 80:2920-2904.

24. Bramley AJ. 1976. Variations in the susceptibility of lactating and non-lactating bovine udders to infection when infused with *Escherichia coli*. *Dairy Res.* 43:205-211.
25. Bufler P, Stiegler G, Shuchmann M, Hess S, Kruger C, Stelter F, Eckerskorn C, Schutt C, and Engelmann H. 1995. Soluble lipopolysaccharide receptor (CD14) is released via two different mechanisms from human monocytes and CD14 transfectants. *Eur J Immunol.* 25:604-610.
26. Burvenich C, Paape MJ, Hill AW, Guidry AJ, Miller RH, Heyneman R, Kremer WD, Brand A. 1994. Role of the neutrophil leucocyte in the local and systemic reactions during experimentally induced *E. coli* mastitis in cows immediately after calving. *Vet Q.* 16:45-50.
27. Burvenich C, Van Merris CJ, Mehrzad J, Diez-Fraile A, and Duchateau L. 2003. Severity of *E. coli* mastitis is mainly determined by cow factors. *Vet Res.* 34:521-564.
28. Butcher C. 1991. Leukocyte-endothelial cell recognition: three (or more) steps to specificity and diversity. *Cell.* 67:1033-1036.
29. Bone RC. 1993. Gram-negative sepsis: a dilemma of modern medicine. *Clin Microbiol Rev.* 6:57-68.
30. Cacalno G, Lee K, Kikly A, Ryan, Pitts-Meek S, Hultgren B, Wood W, Moore M. 1994. Neutrophil and B cell expansion in mice that lack the murine IL-8 receptor homolog. *Science.* 29:590-591.
31. Carroll EJ, Schalm OW, Lasmanis J. 1964. Experimental coliform (*Aerobacter aerogenes*) mastitis: Characteristics of the endotoxin and its role in pathogenesis. *Am J Vet Res.* 25:720-726.
32. Carlson GP, Kaneko J. 1973. Isolation of leukocytes from bovine peripheral blood. *Proc Soc Exp Biol Med.* 142:853-856.
33. Casstella MA. 1995. The production of cytokines by polymorphonuclear neutrophils. *Immunol Today.* 16:21-26.
34. Cassatella MA, Meda L, Gasperini S, Andrea AD, Ma X, Trinchieri G. 1995. Interleukin-12 production by human polymorphonuclear leukocytes. *Eur J Immunol.* 25:1-5.
35. Cassatella MA. 1996. Cytokines produced by polymorphonuclear neutrophils: molecular and biological aspects. R.G. Landes Company, Austin, Texas, USA.

36. Cassatella MA, Gasperini S, and Russo MP. 1997. Cytokine expression and release by neutrophils. *Ann NY Acad Sci.* 832:233-242.
37. Cauwels A, Frei K, Sansano S, Fearnls C, Ulevitch R, Zimmerli W, Landmann R. 1999. The origin and function of soluble CD14 in experimental bacterial meningitis. *J Immunol.* 162:4762-4772.
38. Chapman S, Kavanagh T, Baulcombe D. 1992. Potato virus X as a vector for gene expression in plants. *Plant J.* 2:549-557.
39. Chow JC, Young DW, Golenbock DT, Christ WJ, Gusovsky F. 1999. Toll-like receptor-4 mediates lipopolysaccharide-induced signal transduction. *J Biol Chem.* 274:10689-10692.
40. Craven N. 1986. Chemotactic factors for bovine neutrophils in relation to mastitis. *Comp Immunol Microbiol Infect Dis.* 9:29-36.
41. Crozat K, Beutler B. 2004. TLR7: A new sensor of viral infection. *Proc Natl Acad Sci USA.* 101:6835-6836.
42. Colotta F, Re F, Polentarutti N, Sozzani S, Mantovani A. 1992. Modulation of granulocyte survival and programmed cell death by cytokines and bacterial products. *Blood.* 80:2012-2020.
43. Daley M, Williams T, Coyle P, Furda G, Dougherty R, Hayes P. 1993. Prevention and treatment of *Staphylococcus aureus* infections with recombinant cytokines. *Cytokine.* 5:276-284.
44. Daley MJ, Coyle PA, Williams TJ, Furda G, Dougherty R, Hayes PW. 1991. *Staphylococcus aureus* mastitis: pathogenesis and treatment with bovine interleukin-1 beta and interleukin-2. *J Dairy Sci.* 74:4413-4424.
45. Dbravec DB, Spriggs DR, Mannick JA, Rodrick ML. 1990. Circulating human peripheral blood granulocytes synthesize and secrete tumor necrosis factor. *Proc Natl Acad Sci USA.* 87:6758-6761.
46. Decker T, Stockinger S, Karaghiosoff M, Müller M, and Kovarik P. 2002. IFNs and STATs in innate immunity to microorganisms. *J Clin Invest.* 109:1271-1277.
47. de Haas Y, Barkema HW, Veerkamp RF. 2002. The effect of pathogen-specific clinical mastitis on the lactation curve for somatic cell count. *J Dairy Sci.* 85:1314-1323.
48. Dentener M, Bazil V, Von Asmuth E, Ceska M, Buurman W. 1993. Involvement

- of CD14 in lipopolysaccharide induced tumor necrosis factor-alpha, IL-6 and IL-8 release by human monocytes and alveolar macrophage. *J Immunol.* 150:2885-2891.
49. Desidero JV, Campbell SG. 1980. Bovine mammary gland macrophage:isolation, morphologic features, and cytophilic immunoglobulins. *Am J Vet Res.* 41:1595-1599.
 50. De Waal Malefyt R, Figdor CG, Huijbens R, Mohan-Peterson S, Bennett B, Culpepper L. 1993. Effect of IL-13 on phenotype, cytokines production, and cytotoxic function of human monocytes. *J Immunol.* 151:6370-6381.
 51. Debets J, Kamprmeijer HR, Van der Linden, W.A.Buurman, and C.J. Van der Linden. 1989. Plasma tumor necrosis factor and mortality in critically septic patients. *Crit Care Med.* 17:489-494.
 52. Dentener MA, Bazil V, Asmuth UV, Ceska M, Buuurman WA. 1993. Involvement of CD14 in lipopolysaccharide-induced tumor necrosis factor- α , IL-6 and IL-8 release by human monocytes and alveolar macrophages. *J Immunol.* 150:2885-2891.
 53. Detmers PA, Zhou D, Powell D, Lichenstein H, Kelley M, Pironkova R. 1995. Endotoxin receptors (CD14) are found with CD16 (Fc gamma RIII) in an intracellular compartment of neutrophils that contains alkaline phosphatase. *J Immunol.* 155:2085-2095.
 54. Diez-Fraile A, Meyer E, Duchateau L, Burvenich C. 2004. Effect of pro-inflammatory and glucocorticoids on L-selectin expression in peripheral blood neutrophils from dairy cows in various stages of lactation. *Am J Vet Res.* 65:1421-1426.
 55. Didier JL, Moriarty AM, Talbott G, Winn RK, Martin TR, Ulevitch RJ. 1996. Antibodies against CD14 protect primates from endotoxin-induced shock. *J Clin Invest.* 98:1533-1538.
 56. Dinarello CA. 1997. Proinflammatory and anti-inflammatory cytokines as mediators in the pathogenesis of septic shock. *Chest.* 112:321S-329.
 57. Donnet-Hughes, and Schiffrin EJ. 2000. Innate recognition of bacteria in human milk is mediated by a milk-derived highly expressed pattern recognition receptor, soluble CD14. *J Exp Med.* 191:1807-1812.
 58. Dosogne H, Meyer E, Sturk A, van Loon J, Massart-Leen AM, Burvenich C. 2002. Effect of enrofloxacin treatment on plasma endotoxin during bovine *Escherichia coli* mastitis. *Inflamm Res.* 51:201-205.

59. Duriex JJ, Vita N, Popescu O, Guette F, Calzada-Wack J, Munker R, Schmidt RE, Lupker J, Ferrara P, Ziegler HW, Labeta MO. 1994. The two soluble forms of the lipopolysaccharide receptor, CD14: Characterization and release by normal human monocytes. *Eur J Immunol.* 24:2006-2012.
60. Eberhart RJ, Natzke RP, Newbould FHS, Nonnecke B, Thompson P. 1979. Coliform mastitis review. *J Dairy Sci.* 62:1-22.
61. Eberhart RJ. 1984. Coliform mastitis. *Vet Clin North Am Large Anim Pract.* 6: 287-300.
62. Eckmann L, Stenson WF, Savidge TC, Lowe DC, Barrett KE, Fierer J, Smith JR, Kagnoff MF. 1997. Role of intestinal epithelial cells in the host secretory response to infection by invasive bacteria: bacterial entry induces epithelial prostaglandin H synthase-2 expression and prostaglandin E₂ and F₂ production. *J Clin Invest.* 100:296-309.
63. Erskine RJ, Tyler JW, Riddell MG, Wilson RC. 1991. Theory, use and realities of efficacy and food safety of antimicrobial treatment of acute coliform mastitis. *J Am Vet Med Assoc.* 198: 980-984.
64. Ethuin F, Gerard B, Benna JE, Boutten A, Gougereot-Pocidallo MA, Jacob L, Chollet-Martin S. 2004. Human neutrophils produce interferon gamma upon stimulation by interleukin-12. *Lab Invest.* 84:1363-1371.
65. Fearn C, Krarchenko VV, Ulevitch RJ, Loskutoff DJ. 1995. Murine CD14 gene expression in vivo: Extramyeloid synthesis and regulation by lipopolysaccharide. *J Exp Med.* 181:857-866.
66. Ferrero EF, Goyert SM. 1988. Nucleotide sequence of the gene encoding the monocyte differentiation antigen, CD14. *Nucleic Acids Res.* 16:4173.
67. Feghali CA, and Wright TM. 1997. Cytokines in acute and chronic inflammation. *Front Biosci.* 2:12-26.
68. Fetterer RH, Barfield RC. 2003. Characterization of a developmentally regulated oocyst protein from *Eimeria Tenella*. *J Parasitol.* 89:553-564.
69. Filipp D, Alizadeh-Khiavi, Richardson C, Palma A, Paredes N, Takeuchi O, Akira S, Julius M. 2001. Soluble CD14 enriched in colostrums and milk induces B cell growth and differentiation. *Proc Natl Acad Sci USA.* 98:603-608.
70. Fletcher S, Pearce M, Tewari A, Yim H, Zou J, and Abrams JS. 1990. Anti-IL-6

- monoclonal antibodies protect against lethal *Escherichia coli* infection and lethal tumor necrosis factor- α challenge in mice. *J Immunol.* 145:4185-4191.
71. Foxman EF, Campbell JJ, Butcher EC. 1997. Multistep navigation and the combinational control of leukocyte chemotaxis. *J Cell Biol.* 139:1349-1360.
72. Freyer EA, Miller DS, Jahr TG, Sundan A, Bazil V, Espevik T, Finlay BB, and Wright SD. 1992. Soluble CD14 participates in the response of cells to lipopolysaccharide. *J Exp Med.* 176:1665-1671.
73. Freshney RI. 1994. Culture of animal cells, Third Edition. Wiley-Liss, New York, 107.
74. Frevert CW, Matute-Bello G, Skerrett SJ, Goodman RB, Kajikawa O, Sittipunt C, Martin TR. 2000. Effect of CD14 blockade in rabbits with *Escherichia coli* pneumonia and sepsis. *J Immunol.* 164:5439-5445.
75. Frey EA, Miller DS, Jahr TG, Sundan A, Bazil V, Espevik T, Finlay BB, Wright SD. 1992. Soluble CD14 participates in the response of cells to lipopolysaccharide. *J Exp Med.* 176:1665-1671.
76. Gately MK, Wolitzky AG, Quinn PM, Chizzonite. 1992. Regulation of human cytolytic lymphocyte responses by interleukin-12. *Cell Immunol.* 143:127-142.
77. Gray GD, Knight KA, Nelson RD, Herron MJ. 1982. Chemotactic requirements of bovine leukocytes. *Am J Vet Res.* 43:757-759.
78. Grimm MC, Pavli P, Van de Pol E, Doe WF. 1995. Evidence for a CD14⁺ population of monocytes in inflammatory bowel disease mucosa: implications for pathogenesis. *Clin Exp Immunol.* 100: 291-297.
79. Grohn YT, Wilson DJ, Gonzalez RN, Hertl JA, Schulte H, Bennett G, Schukken YH. 2004. Effect of pathogen-specific clinical mastitis on milk yield in dairy cows. *J Dairy Sci.* 87:3358-3374.
80. Gupta D, Kirkland TN, Viriyakosol S, Dziarski R. 1996. CD14 is a cell-activating receptor for bacterial peptidoglycan. *Biol Chem.* 20:2310-2316.
81. Hakogi E, Tamura H, Tanaka S, Kohata A, Shimada Y, Tabuchi K. 1989. Endotoxin levels in milk and plasma of mastitis-affected cows measured with a chromogenic limulus test. *Vet Microbiol.* 20:267-274.
82. Hailman E, Lichenstein HS, Wurfel MM, Miller DS, Johnson DA, Kelley M,

- Busse LA, Zukowski MM, Wright SD. 1994. Lipopolysaccharide (LPS)-binding protein accelerates the binding of LPS to CD14. *J Exper Med.* 179:269-277.
83. Hailman E, Albers JJ, Wolfbauer G, Tu AY, Wright SD. 1996. Neutralization and transfer of lipopolysaccharide by phospholipid transfer protein. *J Biol Chem.* 271:12172-12178.
84. Weber AF. 1977. The bovine mammary gland. *J Am Vet Med Assoc.* 15:1133-1136.
85. Harris ES, McIntyre TM, Prescott SM, Zimmerman GA. 2000. The leukocyte integrins. *J Biol Chem.* 275:13409-13412.
86. Hattar K, Fink L, Fietzner K, Himmel B, Grimminger F, Seeger W, Sibelius U. 2001. Cell density regulates neutrophil IL-8 synthesis: role of IL-1 receptor antagonist and soluble TNF receptors. *J Immunol.* 15:6287-6293.
87. Haziot A, Cehn S, Ferrero E, Low M, Silber R, Goyert S. 1988. The monocyte differentiation antigen, CD14, is anchored to the cell membrane by a phosphatidylinositol linkage. *J Immunol.* 141:547-552.
88. Haziot A, Tsuberi BZ, Goyert SM. 1993. Neutrophil CD14 biochemical properties and role in the secretion of tumor necrosis factor, recombinant soluble CD14. *J Immunol.* 15:5556-5565.
89. Haziot A, Rong GW, Lin XY, Silver J, Goyert SM. 1995. Recombinant soluble CD14 prevents mortality in mice treated with endotoxin (lipopolysaccharide). *J Immunol.* 15:6529-6532.
90. Haziot A, Ferrero E, Kontgen F, Hijiya N, Yamamoto S, Silver J, Stewart CL, Goyert SM. 1996. Resistance to endotoxin shock and reduced dissemination of Gram-negative bacteria in CD14-deficient mice. *Immunity.* 4:407-414.
91. Haziot A, Lin XY, Zhang F, Goyert SM. 1998. The induction of acute phase proteins by lipopolysaccharide uses a novel pathway that is CD14-independent. *J Immunol.* 160:2570-2572.
92. Heyneman R, Burvenich C, Vercauteren R. 1990. Interaction between the respiratory burst activity of neutrophil leukocytes and experimentally induced *Escherichia coli* mastitis in cows. *J Dairy Sci.* 73:985-994.
93. Hiroyoshi I, Akira T, and Shigemasa H. 2000. Prostaglandin E2 stimulates AP-1-mediated CD14 expression in mouse macrophages via cyclic AMP-dependent protein kinase A. *J Immunol.* 164:5403-5408.
94. Hull S. 1997. In *Escherichia coli: mechanism of virulence*: sussman, Ed; Cambridge

University press: Cambridge. Uk. 145-167.

95. Ingalls RR, Golenbock DT. 1995. CD11c/CD18, a transmembrane signaling receptor for lipopolysaccharide. *J Exp Med.* 181:1473-1479.
96. Ingalls RR, Arnaout MA, Golenbock DT. 1997. Outside-in signaling by lipopolysaccharide through a tailless integrin. *J Immunol.* 1:433-438.
97. Ingalls RR. 1997. Lipopolysaccharide recognition, CD14 and lipopolysaccharide receptors bacterial sepsis and septic shock through a tailless integrin. *J Immunol.* 159:433-438.
98. Jain NC, Schalm OW, and Lasmanis J. 1969. Comparison in normal and leukopenic cows of experimental mastitis due to *Aerobacter aerogenes* or *Escherichia coli* endotoxin. *Am J Vet Res.* 30:715-724.
99. Jain NC. 1986. Schalm's Veterinary Hematology, Lea & Febiger, Philadelphia, PA, USA.
100. Jayaram Y, Hogg N. 1989. Expression of CD14 molecules by human neutrophils. *Tissue Antigens.* 33:199-204.
101. Jutila MA, Rott L, Berg EL, Butcher EC. 1989. Function and regulation of the neutrophil MEL-14 antigen in vivo: comparison with LFA-1 and MAC-1. *J Immunol.* 143:3318-3324.
102. Kasama T, Strieter RM, Lukacs NW, Burdick MD, Kunkel SL. 1994. Regulation of neutrophil-derived chemokine expression by IL-10. *J Immunol.* 152: 3559-3569.
103. Katholm J, Andersen PH. 1992. Acute coliform mastitis in dairy cows: Endotoxin and biochemical changes in plasma and colony-forming units in milk. *Vet Rec.* 13:513-514.
104. Kiniwa M, Gately M, Gubler U, Chizzonite R, Fargeas C, Delespesse G. 1992. Recombinant interleukin-12 suppresses the synthesis of immunoglobulin E by interleukin-4 stimulated human lymphocytes. *J Clin Invest.* 90:262-266.
105. Kirshning CJ, Wesche H, Ayres TM, Rothe M. 1998. Human Toll-like receptor 2 confers responsiveness to bacterial lipopolysaccharide. *J Exp Med.* 188: 2091-2097.
106. Kishimoto TK, Jutila MA, Berg EL, Butcher EC. 1989. Neutrophil MAC-1 and MEL-14 adhesion proteins inversely regulated by chemotactic factors. *Science.* 245:1238-1241.

107. Klein CL, Bittinger F, Kohler H, Wagner M, Otto M, Hermanns I, Kirkpatrick CJ. 1995. Comparative studies on vascular endothelium *in vitro*. *Pathobiology*. 63:204-212.
108. Klein CL, Bittinger F, Skarke CC, Wagner M, Kohler H, Walgenbach S, Kirkpatrick CJ. 1995. Effects of cytokines on the expression of cell adhesion molecules by cultured human mesothelial cells. *Pathobiology*. 64:204-212.
109. Kurt-Jones EA, Mandell L, Whitney C, Padgett A, Gosselin K, Newburger PE, Finberg RW. 2002. Role of Toll-like receptor 2 (TLR2) expression in neutrophil activation:GM-CSF enhances TLR2 expression and TLR-2 mediated interleukin-8 responses in neutrophils. *Blood*. 100:1860-1868.
110. Labéta MO, Durieux JJ, Fernandes N, Herrmann R, Ferrara P. 1993. Release from a human monocyte-like cell line of two different soluble forms of the lipopolysaccharide receptor, CD14. *Eur J Immunol*. 23:2144-2151.
111. Labéta MO, Vidal K, Nores JER, Arias M, Vita N, Morgan BP, Guillemot JC, Loyaux D, Ferrara P, Schmid D, Affolter M, Borysiewicz LK. 2000. Innate recognition of bacteria in human milk is mediated by a milk-derived highly expressed pattern recognition receptor, soluble CD14. *J Exp Med*. 15:1807-1812.
112. Landmann R, Ludwig C, Obrist R, Obrecht JP. 1991. Effect of cytokines and lipopolysaccharide on CD14 antigen expression in human monocytes and macrophages. *J Cell Biochem*. 47:317-329.
113. Landmann R, Muller B, Zimmerli W. 2000. CD14, new aspects of ligand and signal diversity. *Microbes Infect*. 2:295-304.
114. Larsen CG, Anderson AO, Oppenheim JJ, Matsushima K. 1989. Production of IL-8 by human dermal fibroblasts and keratinocytes in response to IL-1 or tumor necrosis factor. *Immunology*. 68:31-36.
115. Lau D, Mollnau H, Eiserich JP, Freeman BA, Daiber A, Gehling UM, Brummer J, Rudolph V, Munzel T, Heitzer T, Meinertz T, Baldus S. 2005. Myeloperoxidase mediates neutrophil activation by association with CD11b/CD18 integrins. *Proc Natl Acad Sci USA*. 11:431-436.
116. Lee A, Whyte MK, Haslett C. 1993. Inhibition of apoptosis and prolongation of neutrophil function longevity by inflammatory mediators. *J Leukocyte Biol*. 54:283-288.
117. Lee JW, Paape MJ, Elsasser TH, Zhao X. 2003. Elevated milk soluble CD14 in

bovine mammary gland challenged with *Escherichia coli* lipopolysaccharide. *J Dairy Sci.* 86:2282-2289.

118. Lee JW, Paape MJ, Zhao X. 2003. Recombinant bovine soluble CD14 reduces severity of experimental *Escherichia coli* mastitis in mice. *Vet Res.* 34:307-316.
119. Lee JW, Paape MJ, Elsasser TH, Zhao X. 2003. Recombinant soluble CD14 reduces severity of intramammary infection by *Escherichia coli*. *Infect Immun.* 71:4034-4039.
120. Lee JW, Zhao X. 2000. Recombination human interleukin-8, but not human interleukin-1 beta induces bovine neutrophil migration in an invitro-coculture system. *Cell Biol Int.* 24:889-895.
121. Lee KH, Lawley TJ, Xu YL, Swerlick RA. 1992. VCAM-1-, ELAM-1-, and ICAM-1-independent adhesion of melanoma cells to cultured human dermal microvascular endothelial cells. *Invest Dermatol.* 98:79-85.
122. Leturcq DJ, Moriarty AM, Talbott RK. 1996. Antibodies against CD14 protect primates from endotoxin induced shock. *J Clin Invest.* 98:1533-1541.
123. Leung TF, Tang NL, Wong GW, Fok TF. 2005. CD14 and Toll-like receptors: potential contribution of genetic factors and mechanisms to inflammatory and allergy. *Curr Drug Targets Inflamm Allergy.* 4:169-175.
124. Loppnow H, Stelter F, Schonbeck U, Schuler C, Ernst M, Schutt C, Fald HD. 1995. Endotoxin activates human vascular smooth muscle cells despite lack of expression C14 mRNA or endogenous membrane CD14. *Infect Immun.* 63:1020-1026.
125. Lutcke HA, Chow KC, Mickel FS, Moss KA, Kern HF. 1987. Scheele GA. Selection of AUG initiation codons differs in plants and animals. *EMBO J.* 6:43-48.
126. Lynam EB, Simon SI, Rochon YP, Sklar LA. 1994. Lipopolysaccharide enhances CD11b/CD18 function but inhibits neutrophil aggregation. *Blood.* 83:3303.
127. Lynam EE, Simon SI, Rochon YP, Sklar LA. 1994. Lipopolysaccharide enhances CD11b/CD18 function but inhibits neutrophil aggregation. *Blood.* 83:3303-3311.
128. Lynn WA, Liu Y, Golenbock DT. 1993. Neither CD14 nor serum is absolutely necessary for activation of mononuclear phagocytes by bacterial lipopolysaccharide. *Infect Immun.* 61:4452-4461.

129. Maliszewski CR. 1991. CD14 and immune response to lipopolysaccharide. *Science*. 252:1231-1322.
130. Maliszewski CR, Ball E, Graziano R, Fanger M. 1985. Isolation and characterization of My 23, a myeloid cell-derived antigen reactive with the monoclonal antibody AML-2-23. *J Immunol*. 135:1926-1936.
131. Ma JK. 2000. Genes, greens, and vaccines. *Nat Biotechnol*. 18:1141-1142.
132. Ma JK, Drake PM, Christou P. 2003. The production of recombinant pharmaceutical proteins in plants. *Nat Rev Genet*. 4:794-805.
133. Mason HS, Ball JM, Shi JJ, Jiang X, Estes MK, Arntzen CJ. 1996. Expression of Norwalk virus capsid protein in transgenic tobacco and potato and its oral immunogenicity in mice. *Proc Natl Acad Sci USA*. 93:5335-5340.
134. Martin M, Katz J, Vogel S, Michalek S. 2001. Differential induction of endotoxin tolerance by lipopolysaccharides derived from *Porphyromonas gingivalis* and *Escherichia coli*. *J Immunol*. 167:5278-5285.
135. Martin T, Rubenfeld G, Ruzinski J, Goodman R, Steinberg K, Leturcq D, Moriarty A, Raghu G, Baughman R, and Hudson L. 1997. Relationship between soluble CD14, lipopolysaccharide binding protein, and the alveolar inflammatory response in patients with acute respiratory distress syndrome. *Am J Respir Crit Care Med*. 155:937-944.
136. Mattila T, Frost A. 1989. Induction by endotoxin of the inflammatory response in the lactating and dry bovine mammary gland. *Res Vet Sci*. 46:238-240.
137. Meda L, Gasperini S, Ceska M, and Cassatella MA. 1994. Modulation of pro-inflammatory cytokines release from human polymorphonuclear leukocytes by γ interferon. *Cell Immunol*. 157:448-461.
138. Medzhitow R, Preston-Hurlburt P, Janeway C. 1997. A human homologue of the *Drosophila* Toll protein signals activation of adaptive immunity. *Nature*. 24:394-397.
139. Medvedev A, Kopydlowski K, Vogel S. 2000. Inhibition of lipopolysaccharide-induced signal transduction in endotoxin-tolerized mouse macrophages: dysregulation of cytokine, chemokine, and toll-like receptor 2 and 4 gene expression. *J Immunol*. 1:5564-5574.
140. Mehrzad J, Dosogne H, Meyer E, Burvenich C. 2001. Local and systemic effects of

- endotoxin mastitis on the chemiluminescence of milk and blood neutrophils in dairy cows. *Vet Res.* 32:131-144.
141. Miller RH, Paape MJ, Acton JC. 1986. Comparison of milk somatic cell counts by Coulter and Fossomatic Counters. *J Dairy Sci.* 69:1942-1946.
142. Miller RH, Paape MJ, Fulton LA. 1993. The relationship of milk somatic cell count to milk yield for Hostein heifers after first calving. *J Dairy Sci.* 76:728-733.
143. Mollinedo F, Borregaard N, Boxer LA. 1999. Novel trends in neutrophil structure, function and development. *Immunol Today.* 20:535-537.
144. Muroi M, Ohnishi T, Tanamoto K. 2002. Regions of the mouse CD14 molecule required for toll-like receptor 2-and 4-mediated activation of NF-kappa B. *J Biol Chem.* 277:42372-42379.
145. National Mastitis Council. 1996. Current Concepts of Bovine Mastitis, 4th Edition. National Mastitis Council, Madison, WI.
146. Nemoto E, Sugawara S, Tada H, Takada H, Shimauchi H, Horiuchi H. 2000. Cleavage of CD14 on human gingival fibroblasts cocultured with activated neutrophils is mediated by human leukocyte lipopolysaccharide-induced IL-8 production. *J Immunol.* 15:5807-5813.
147. Nickerson SC, Baker PA, Trinidad P. 1989. Local immunostimulation of the bovine mammary gland with interleukin-2. *J Dairy Sci.* 72:1764-1773.
148. Nourshargh S, Perkins J, Showell H, Matsushima M, Williams T, Collins P. 1992. A comparative study of the neutrophil stimulatory activity in vitro and proinflammatory properties in vivo of 72 amino acid and 77 amino acid IL-8. *J Immunol.* 48:106-111.
149. Ohmann HB, Campus M, McDougall L, Lawman MJP, Babiuk LA. 1990. Expression of tumor necrosis factor- α receptors on bovine macrophages, Lymphocytes and polymorphonuclear leukocytes, internalization of receptor-bound ligand, and some functional effects. *Lymphokine Res.* 9:43-58.
150. Östensson K, Hageltorn M, Aström G. 1998. Differential cell counting in fractions collected milk from dairy cows. *Acta Veterinaria Scandinavica.* 29:493-500.
151. Paape MJ, Lilius EM, Wiitanen PA, Konitio MP, Miller RH. 1996. Intramammary defense against infections induced by *Escherichia coli* in cows. *Am J Vet Res.* 4:477-482.

152. Burvenich C, Paape MJ, Hill, Guidry AW, Miller RH, Heyneman R, Kremer WD, Brand A. 1994. Role of the neutrophil leukocyte in the local and systemic reactions during experimentally induced *E.coli* mastitis in cows immediately after calving. *Vet Q.* 16:45-50.
153. Paape MJ, Lilius EM, Wiitanen PA, Kontio MP, Miller RH. 1996. Intramammary defense against infections induced by *Escherichia coli* in cows. *Am J Vet Res.* 57:477-482.
154. Paape MJ, Rautiainen PM, Lilius EM, Malstrom CE, Elsasser TH. 2002. Development of anti-bovine TNF-alpha mAb and ELISA for quantitating TNF- α in milk after intramammary injection of endotoxin. *J Dairy Sci.* 85:765-773.
155. Paape MJ, Bannerman DD, Zhao X, Lee JW. 2003. The bovine neutrophil: Structure and function in blood and milk. *Vet Res.* 34:597-627.
156. Paape MJ, Schultze WD, Desjardins C, Miller RH. 1974. Plasma corticosteroid, circulating leukocyte and milk somatic cell responses to *Escherichia coli* endotoxin-induced mastitis. *Proc Soc Exp Biol Med.* 145:553-559.
157. Parsons PE, Gillespie MM, Moore EE, Moore FA, Worthen GS. 1995. Neutrophil response to endotoxin in the adult respiratory distress syndrome: role of CD14. *Am J Respir Cell Mol Biol.* 1:152-160.
158. Payne CM, Glasser L, Tischler ME, Wyckoff D, Cromey D, Fiederlein R, Bohnert O. 1994. Programmed cell death of the normal human neutrophil: An in vitro model of senescence. *Microsc Res Tech.* 28:327-344.
159. Perera PY, Vogel SN, Detore GR, Haziot A, Goyert SM. 1997. CD14-dependent and CD14-independent signaling pathways in murine macrophages from normal and CD14 knockout mice stimulated with lipopolysaccharide or taxol. *J Immunol.* 158:4422-4429.
160. Peveri P, Walz A, Dewald B, Baggiolini M. 1988. A novel neutrophil activating factor produced by human mononuclear phagocytes. *J Exp Med.* 167:1547-1559.
161. Poltorak A, He X, Smirnova I, Liu MY, Van Huffel C, Du X, Birdwell D, Alejos E, Silva M, Galanos C, Freudenberg M, Ricciardi-Castagnoli P, Layton B, Beutler B. 1998. Defective LPS signaling in C3H/He J and C57BL/10Sc Cr mice: mutations in Tlr-4 gene. *Science.* 282:2085-2088.
162. Pugin J, Heumann ID, Tomasz A, Kravchenko VV, Akamatsu Y, Nishijima M,

- Glauser MP, Tobias PS, Ulevitch RJ. 1994. CD14 is a pattern recognition receptor. *Immunity*. 1:509-516.
163. Pugin J, Ulevitch RJ, Tobias PS. 1995. Activation of endothelial cells by endotoxin: direct versus indirect pathways and the role of CD14. *Prog Clin Biol Res*. 392:369-373.
164. Pugin J, Heumann D, Tomzas A, Kravchenko VV, Akamatsu Y, Nishijima M, Glauser MP, Tobias PS, Ulevitch RJ. 1994. CD14 is a pattern recognition receptor. *Immunity*. 1:509-516.
165. Rabinowich H, Herbeman RB, Whiteside TL. 1993. Differential effects of IL-12 and IL-2 on expression and function of cellular adhesion molecules on purified human NK cells. *Cell Immunol*. 152:481-498.
166. Raetz CR. 1993. Bacterial endotoxins: extraordinary lipids that activate eucaryotic signal transduction. *J Bacteriol*. 175:5745-5753.
167. Randow F, Syrbe U, Meisel C, Krausch D, Zuckermann H, Platzer C, Volk HD. 1995. Mechanism of endotoxin desensitization: involvement of interleukin 10 and transforming growth factor beta. *J Exp Med*. 1:1887-1892.
168. Reddi K, Phagoo SB, Anderson KD, Warburton D. 2003. *Burkholderia cepacia*-induced IL-8 gene expression in an alveolar epithelial cell line: signalling through CD14 and mitogen-activated protein kinase. *Pediatric research*. 54:297-305.
169. Reddy PG, Blecha F, Minocha HC, Anderson GA, Morrill JL, Fedorka-Cray PJ, Baker PE. 1989. Bovine recombinant interleukin-2 augments immunity and resistance to bovine herpesvirus infection. *Vet Immunol Immunopathol*. 30:61-74.
170. Riollot C, Rainard P, Poutrel B. 2000. Cells and cytokines in inflammatory secretion of bovine mammary gland. *Adv Exp Med Biol*. 480:247-258.
171. Riollot C, Painard P, Poutrel B. 2000. Kinetics of cells and cytokines during immune-mediated inflammation in the mammary gland of cows systemically immunized with *Staphylococcus aureus* alpha-toxin. *Inflamm Res*. 49:486-496.
172. Riollot C, Rainard P, Poutrel B. 2000. Differential induction of complement fragment C5a and inflammatory cytokines during intramammary infections with *Escherichia coli* and *Staphylococcus aureus*. *Clin Diagn Lab Immunol*. 7:161-167.
173. Robson RL, McLoughlin RM, Witowski J, Loetscher P, Wilkinson TS, Jones SA,

- Topley N. 2001. Differential regulation of chemokine production in human Peritoneal mesothelial cells: INF-gamma controls neutrophil migration across the mesothelium *in vitro* and *in vivo*. *J Immunol.* 167:1028-1038.
174. Roderberg DA, Morris RE, Babcock GF. 1997. Azurophilic granules of human neutrophils contain CD14. *Infect Immun.* 65:4747-4753.
175. Ross GD, Vetvicka V. 1993. CR3 (CD11b, CD18): a phagocyte and NK cell membrane receptor with multiple ligand specificities and functions. *Clin Exp Immunol.* 92:181-184.
176. Royall JA, Berkow RL, Beckman JS, Cunningham MK, Matalon S, Freeman BA. 1989. Tumor necrosis factor and interleukin 1 alpha increase vascular endothelial permeability. *Am J Physiol.* 257:L399-410.
177. Savedra R Jr, Delude RL, Ingalls RR, Fenton MJ, Golenbock DT. 1996. Mycobacterial lipoarabinomannan recognition requires a receptor that shares components of the endotoxin signaling system. *J Immunol.* 15:2549-2554.
178. Schletter J, Heine H, Ulmer AJ, Rietschel ET. 1995. Molecular mechanisms of endotoxin activity. *Arch Microbiol.* 164:383-389.
179. Schnyder-Candrian S, Strieter RM, Kunker SL, Walz A. 1995. Interferon-alpha and interferon-gamma down-regulate the production of interleukin-8 and ENA-78 in human monocytes. *J Leukoc Biol.* 57:929-935.
181. Schmaljohn CS, Chu YK, Schmaljohn AL, Dalrymple JM. 1990. Antigenic subunits of Hantaan virus expressed by baculovirus and vaccinia virus recombinants. *J Virol.* 64:3162-3170.
182. Schumann RR, Leong SR, Flaggs GW, Gray PW, Wright SD, Mathison JC, Tobias PS, Ulevitch RJ. 1990. Structure and function of lipopolysaccharide binding protein. *Science.* 249:1429-1431.
183. Schutt C, Schilling T, Grunwald U, Schonfeld W, Kruger C. 1992. Endotoxin neutralizing capacity of soluble CD14. *Res Immunol.* 143:71-78.
184. Schimke J, Mathison J, Morgiewicz J, Ulevitch R. 1998. Anti-CD14 mAb treatment provides therapeutic benefit after *in vivo* exposure to endotoxin. *Proc Natl Acad Sci USA.* 95:13875-13880.
185. Seiler P, Aichele P, Raupach B, Odermatt B, Steinhoff U, Kaufmann HE. 2000. Rapid neutrophil response controls fast-replicating intracellular bacteria but not slow-replicating *mycobacterium tuberculosis*. *J Infect Dis.* 181:67-80.

186. Sengelov IL, Kjeldsen L, Diamond MS, Springer TA, Borregaard N. 1993. Subcellular localization and dynamics of Mac-1 (α M β 2) in human neutrophils. *J Clin Invest.* 92:1467-1476.
187. Shapiro RA, Cunningham MD, Ratcliffe K, Seachord C, Blake J, Bajorath A, Aruffo A, Dadveau P. 1997. Identification of CD14 residues involved in specific lipopolysaccharide recognition. *Infect Immun.* 243:100-109.
188. Shilo M. 1959. Non-specific resistance to infection. *Ann Rev Microbiol.* 13:255-270.
189. Shimazu R, Akashi S, Ogata H, Nagai Y, Fukudome K, Miyake K, Kimoto M. 1999. MD-2, a molecule that confers lipopolysaccharide responsiveness on Toll-like receptor 4. *J Exp Med.* 189:1777-1782.
190. Shimizu T, Yokota SI, Takahashi S, Kunishima Y, Takeyama K, Masumori N, Takahashi A, Naoki M, Taiji Tsukamoto T, Fujii N. 2004. Membrane-anchored CD14 is important for induction of interleukin-8 by lipopolysaccharide and peptidoglycan in uroepithelial cells. *Clinical and Diagnostic Laboratory Immunology.* 11:969.
191. Shuster DE, Kehrli ME, Rainard P, Paape MJ. 1997. Complement fragment C5a and inflammatory cytokines in neutrophil recruitment during intramammary infections with *Escherichia coli*. *Infect Immun.* 65:3286-3292.
192. Shuster DE, Lee EK, Kehrli ME. 1996. Bacterial growth, inflammatory cytokine production, and neutrophil recruitment during coliform mastitis in cows within ten days after calving compared with cows at midlactation. *Am J Vet Res.* 57:1569-1575.
193. Shuster DE, Kehrli ME, Stevens MG. 1993. Cytokine production during endotoxin – induced mastitis in lactating dairy cows. *Am J Vet Res.* 54:80-85.
194. Smits E, Burvenich C, Guidry AJ, Heyneman R, Massart-Leen AM. 2000. Adhesion receptor CD11b/CD18 contributes to neutrophil diapedesis across the bovine blood-milk barrier. *Vet Immunol.* 73:255-265.
195. Smith KL, Hogan JS. 1993. Environmental mastitis. W.B. Saunders Company. 489-498.
196. Smits E, Burvenich C, Guidry AJ, Heyneman R, Massart-Leen A. 1999. Diapedesis across mammary epithelium reduces phagocytic and oxidative burst of bovine neutrophils. *Vet Immunol Immunopathol.* 68:169-176.
197. Smits E, Burvenich C, Guidry AJ, Massart-Leen A. 2000. Adhesion receptor

- CD11b/CD18 contributes to neutrophil diapedesis across the bovine blood-milk barrier. *Vet Immunol Immunopathol.* 15:255-265.
198. Sohn EJ, Paape MJ, Peters RR, Fetterer RH, Talbot NC, Bannerman DD. 2004. The production and characterization of anti-bovine CD14 monoclonal antibodies. *Vet Res.* 35:597-608.
199. Sordillo LM, Streicher KL. 2002. Mammary gland immunity and mastitis susceptibility. *J Mammary Gland Biol Neoplasia.* 7:135-146.
200. Sordillo LM, Babiuk LA. 1991. Modulation of bovine mammary neutrophil function during the periparturient period following in vitro exposure to recombinant bovine interferon gamma. *Vet Immunol Immunopathol.* 27:393-402.
201. Springer TA. 1994. Traffic signals for lymphocyte recirculation and leukocyte emigration: The multistep paradigm. *Cell.* 76:301-314.
202. Stelter F, Bernheiden M, Menzel R, Jack RS, Witt S, Fan X, Phister M, Schutt C. 1997. Mutation of amino acid 39-44 of human CD14 abrogates binding of lipopolysaccharide and *Escherichia coli*. *Eur J Biochem.* 243:100-109.
203. Steinbeck MJ, Roth JA. 1989. Neutrophil activation by recombinant cytokines. *Rev Infect Dis.* 11:549-568.
204. Stelter F, Pfister M, Bernheiden M, Jack RS, Bufler P, Engelmann H, Schutt C. 1996. The myeloid differentiation antigen CD14 in N- and O-glycosylated: contribution of N-linked glycosylation to different soluble CD14 isoforms. *Eur J Biochem.* 236:457-464.
205. Stelter F, Witt S, Furl B, Jack RS, Hartung T, Schutt C. 1998. Different efficacy of soluble CD14 treatment in high and low dose LPS. *J Immunol.* 15:5556-5565.
206. Struyf S, Van Collie E, Paemen L, Put W, Lenaerts JP, Proost P, Opdenakker G, Van Damme J. 1998. Synergistic induction of MCP-1 and -2 by IL-1 β and interferons in fibroblasts and epithelial cells. *J Leukoc Biol.* 63:364-372.
207. Streatfield S J, Howard JA. 2003. Plant-based vaccines. *Int J Parasitol.* 33:479-493.
208. Takeuchi O, Hoshino K, Kawai T, Sanjo H, Takada H, Ogawa T, Takeda K, Akira S. 1999. Differential roles of TLR2 and TLR4 in recognition of Gram-negative and Gram-positive bacterial cell wall components. *Immunity.* 11:443-451.

209. Taub DD, Lloyd AR, Wang JM, Oppenheim JJ, Kelvin DJ. 1993. The effects of human recombinant MIP-1 alpha, MIP-1 beta, and RANTES on the chemotaxis and adhesion of T cell subsets. *Adv Exp Med Biol.* 351:139-146.
210. Tobias PS, Soldau K, Ulevitch RJ. 1986. Isolation of a lipopolysaccharide-binding acute phase reactant from rabbit serum. *J Exp Med.* 71:285-293.
211. Tobias PS, Soldau K, Gegner JA, Mintz D, Ulevitch RJ. 1995. Lipopolysaccharide binding protein-mediated complexation of lipopolysaccharide with soluble CD14. *J Biol Chem.* 270:10482-10488.
212. Trine L, Bjarne Ø. 2004. The effect of TNF- α , PMA, and LPS on plasma and cell associated IL-8 in human leukocytes. *Thrombosis Research.* 113:75-83.
213. Trincheri G. 1995. Interleukin-12: a proinflammatory cytokine with immunoregulatory functions that bridge innate resistance and antigen-specific adaptive immunity. *Annu Rev Immunol.* 13:251-276.
214. Triantafilou M, Triantafilou K, Fernandez N. 2000. Rough and smooth forms of fluorescein-labelled bacteria endotoxin exhibit CD14/LBP dependent and independent binding that is influenced by endotoxin concentration. *Eur J Biochem.* 8:2218-2226.
215. Triantafilou M, Triantafilou K. 2002. Lipopolysaccharide recognition: CD14, TLRs and the LPS-activation cluster. *Trends Immunol.* 23:301-304.
216. Troelstra A, de Graaf-Miltenburg LA, van Bommel T, Verhoef J, Van Kessel KP, Van Strijp JA. 1999. Lipopolysaccharide-coated erythrocytes activate human neutrophils via CD14 while subsequent binding is through CD11b/CD18. *J Immunol.* 1:4220-4225.
217. Ulevitch RJ, Tobias PS. 1999. Recognition of Gram-negative bacteria and endotoxin by the innate immune system. *Curr Opin Immunol.* 11:19-22.
218. Waage S, Mork T, Roros A, Aasland D, Hunshamar A, Odegaard SA. 1999. Bacteria associated with clinical mastitis in dairy heifers. *J Dairy Sci.* 82:712-719.
219. Wang Y, Zarlenga DS, Paape MJ, Dahl GE. 2002. Recombinant bovine soluble CD14 sensitizes the mammary gland to lipopolysaccharide. *Vet Immunol Immunopathol.* 86:115-124.
220. Wang Y, Paape MJ, Leino L, Capuco AV, Narva H. 1997. Functional and phenotypic characterization of monoclonal antibodies to bovine L-selectin. *Am J Vet Res.* 58:1392-1401.

221. Watson RWG, Redmond HP, Wang JH, Bouchier-Hayes D. 1996. Bacterial ingestion, tumor necrosis factor-alpha, and heat induce programmed cell death in activated neutrophils. *Shock*. 5:47-51.
222. Watson RW, Redmond HP, Wang JH, Condrón C, Bouchier-Hayes D. 1996. Neutrophils undergo apoptosis following ingestion of *Escherichia coli*. *J Immunol*. 15:3986-3992.
223. Weiss SJ. 1989. Mechanisms of disease: tissue destruction by neutrophils. *N Engl J Med*. 320:365-376.
224. Wertheim WA, Kunkel SL, Standford TJ, Burdick MD, Becker FS, Wilke CA, Gilbert AR, Strieter RM. 1993. Regulation of neutrophil-derived IL-8: the role of prostaglandin E₂, dexamethasone, and IL-4. *J Immunol*. 151:2166-2175.
225. Wilson RW, Ballantyne CM, Smith CW, Montgomery C, Bardley A, O'Brien WE, Beaudet AL. 1993. Gene targeting yields a CD18-mutant mouse for study of inflammation. *J Immunol*. 151:1571-1578.
226. Wright SD, Tóll. 1999. A new piece in the puzzle of innate immunity. *J Exp Med*. 5:605-609.
227. Wright SD, Ramos RA, Tobias PS, Ulevitch RJ, Mathison JC. 1990. CD14, a receptor for complexes of lipopolysaccharide (LPS) and LPS binding protein. *Science*. 249:1431-1433.
228. Wurfel MM, Hailman E, Wright SD. 1995. Soluble CD14 acts as a shuttle in the neutralization of lipopolysaccharide (LPS) by LPS-binding protein and reconstituted high density lipoprotein. *Exp Med*. 1:1743-1754.
229. Yang RB, Mark MR, Huang A, Xie MH, Zang M, Goddard A, Wood WI, Gurney AL, Godowski PJ. 1998. Toll-like receptor-2 mediates lipopolysaccharide-induced cellular signaling. *Nature*. 395:284-288.
230. Yethon JA, Whitfield C. 2001. Lipopolysaccharide as a target for the development of novel therapeutics in gram-negative bacteria. *Curr Drug Targets Infect Disord*. 2:91-106.
231. Yoshimatsu K, Arikawa J, Kariwa H. 1993. Application of a recombinant baculovirus expressing hantavirus nucleocapsid protein as a diagnostic antigen in IFA test: cross reactivities among 3 serotypes of hantavirus which causes hemorrhagic fever with renal syndrome (HFRS). *J Vet Med Sci*. 55:1047-1050.

232. Yusibov V, Modelska A, Steplewski K, Agadjanyan M, Weiner D, Hooper DC, Koprowski H. 1997. Antigens produced in plants by infection with chimeric plant viruses immunize against rabies virus and HIV-1. *Proc Natl Acad Sci U S A*. 27:5784-5788.
233. Zhou X, Gao XP, Fan J, Liu Q, Anwar KN, Frey RS, Malik AB. 2004. LPS activation of toll-like receptor (TLR4) signals CD11b/CD18 expression in neutrophils. *Am J Physiol Lung Cell Mol Physiol*. 288:655-662.
234. Van Amersfoort ES, Van Berkel TJ, Kuiper J. 2003. Receptors, mediators and mechanisms involved in bacterial sepsis shock. *Clin Microbiol Rev*. 16:379-414.
235. Van Furth AM, Verhard-Seijmonsbergen EM, Langermans JAM, Van Dissel JT, Van Furth R. 1999. Anti-CD14 monoclonal antibodies inhibit the production of tumor necrosis factor alpha and interleukin-10 by human monocytes stimulated with killed and live *Haemophilus influenzae* or *Streptococcus pneumoniae* organisms. *Infect Immun*. 67:3714-3718.
236. Van Oostveldt K, Paape MJ, Dosogne H, Burvenich C. 2002. Effect of apoptosis on phagocytosis, respiratory burst and CD18 adhesion receptor expression of bovine neutrophils. *Domest Anim Endocrinol*. 22:37-50.
237. Vandeputte-Van Messom G, Burvenich C, Roets E, Massart-Leën A, Heyneman R, Kremer WDK, and Brand A. 1993. Classification of newly calved cows into moderate and severe responders to experimentally induced *Escherichia coli* mastitis. *J Dairy Res*. 60:19-29.
238. Van Oostveldt K, Tomita GM, Paape MJ, Capuco AV, Burvenichh C. 2002. Apoptosis of bovine neutrophils during mastitis experimentally induced with *Escherichia coli* or endotoxin. *Am J Vet Res*. 63:448-453.
239. Verbon A, Dekkers PE, Van Hove T, Hack CE, Pribble JP, Turner T, Souza S, Axtelle T, Hoek FJ, Van Deventer SJ, Van der Poll T. 2001. IC, anti-CD14 antibody, inhibits endotoxin-mediated symptoms and inflammatory responses in humans. *J Immunol*. 166:3599-3605.
240. Viriyakosol S, Kirkland TN. 1996. The N-terminal half of membrane CD14 is a functional cellular lipopolysaccharide receptor. *Infect Immunity*. 64:653-656.
251. Glauser MP, Heumann D, Baumgartner JD, Cohen J. 1994. Pathogenesis and potential strategies for prevention and treatment of septic shock: an update. *Clin Infect Dis*. 2:S205-216.