

ABSTRACT

Title of Document: REVERSING THE PROCESS: TAKING A
DETAIL TO A DESIGN

Zachary Ryan Schooley, Master's of
Architecture, 2009

Directed By: Associate Professor, Brian P. Kelly, AIA,
School of Architecture, Planning, and
Preservation

A comprehensive understanding of the development of the architectural detail is currently lacking in the professional education of architects. Detail development is normally seen as the end product of an architectural design process. In academic settings the majority of time is devoted to abstract generalizations, parti development, and schematic design. This thesis will reverse the typical architectural design process by taking a detail to a design. By using the proposed Washington, D.C. 'Purple-line' light-rail initiative as a vehicle for study, a framework to support an in-depth exploration of tectonic, conditional details will be developed. These prototypical details will require adaptations due to location or function, yet will need to exhibit a unifying language for the overall identification of the line. This proposition will pursue an alternative to the traditional architectural design methodology. By implementing detail development at the beginning of the design process, a deeper educational experience can be achieved.

REVERSING THE PROCESS: TAKING A DETAIL TO A DESIGN

By

Zachary Ryan Schooley

Thesis submitted to the Faculty of the Graduate School of the
University of Maryland, College Park, in partial fulfillment
of the requirements for the degree of
Master's of Architecture
2009

Advisory Committee:
Associate Professor, Brian P. Kelly, AIA, Chair
Assistant Professor, Deborah Oakley, RA, PE
Lecturer, Julie Ju-Youn Kim, RA

© Copyright by
Zachary Ryan Schooley
2009

Preface

I have come to enjoy structurally expressive architecture and find that when structure is expressed down to even the smallest joint, a more complete architecture is developed. Up to this point in my architectural education, there has not been enough time allotted for exploration in this sector of design. The typical curriculum, thus far, does not allow for this amount of design progression before one has to move on to another project or assignment. This thesis will embark on a procedural reversal and use the design and development of these details to pursue an alternative architectural process. This system will become the basis for a new family of built interventions along the proposed ‘purple line,’ light-rail initiative.

This kit-of-parts, per se, will generate a number of architectural elements that can be used for a variety of purposes. From the general need for shelter on platforms, canopies, enclosures, and other weather-protective devices will be created. However, details will be developed along a variety of scales to include even elements for newspaper distribution, trash collection, seating, way-finding, and signage. Different locales may then intuit variation and versioning for each of these elements as the design process moves along. These implementations, beginning from the design of details at a micro level, will, at a macro level, inform the basis of an infrastructure to signify the purple line.

Dedication

This work is dedicated to all my friends and family who have always been there and encouraged me to pursue these architectural endeavors. They have been there through all the hard work and restless nights. I could not have asked for a better group of people to be supportive when I needed them. Also to the members of my thesis committee who got me through this process in an efficient, timely, and productive manner, and who stayed excited with me for the entire journey along this somewhat atypical thesis.

Acknowledgements

Thanks to all of my family and friends and especially the members of my thesis committee who saw this until the end. Thanks to all of the consultants who were brought on at different points in this process to add insightful information and provide a fresh look on everything. A special thanks to structural engineering consultant, Chris Cobb who helped me to successfully interface my final station stop columns to the ground. Thanks to George Alexiou and the rest of the help from M/A/B Transportation consultants who helped me to learn everything I needed to know about planning for light-rail. Thanks to our Kea Professor, Frances Halsband for taking the time out of her busy schedule to assist our class with a great amount of energy and enthusiasm and again providing useful insights to all of our projects. Thanks to Professor Santiago Perez from the University of Houston for assisting me with finding literature on prefabrication and digital technologies. Thanks to Professor Michael Ambrose for all of his assistance with our rapid prototyping technology. Thanks to shop supervisor Tom Swift for all of his year long help in model making, building arrangement, model suggestions, and critiques. Also I would like to personally thank Stan Mathurin for helping me to 3d-print something on a Friday night, Brett Swiatocha for helping me with my final layout, Artur Kalil for helping me hold my final model in place while I glued the last pieces, Rob Sanz for helping with pinning up my final presentation, and finally Kat Shieh who has always been by my side whenever she can, and for basically building the majority of my final model. Finally thanks to those I know I have forgotten here, I could not have made it without everyone's constant guidance and support.

Table of Contents

Preface	ii
Dedication.....	iii
Acknowledgements.....	iv
Table of Contents.....	v
List of Figures.....	ix
Introduction.....	1
Inspiration	1
Details	1
Firms and Buildings.....	3
Goals	6
Reversing the Design Process and the Legitimacy of this Proposition	6
Exploration of New Detail Design Methods.....	7
Development of a Kit-of-Parts.....	8
Evaluation of the Current Profession with Regard to Detail Development.....	8
Major Issues to Investigate	10
Notion of 'Craft'	10
Notion of 'Scale'	10
Notion of 'Materiality'	11
Notion of 'Didactic Architecture'	12
Notion of 'Sustainability'	12
Putting Ideas into Action	13
Preliminary Detail Development	13
Analysis of Existing Inspirational Details	13
History and Intent of the 'Purple Line' System.....	14
Cataloguing and Analysis of Required System Elements.....	14
Initial and Refined Methods of Detail Design and Development and a Kit-of-Parts.....	14
Propositions for Implementation.....	15
Chapter 1: Preliminary Detail Development	16
Pencil to Paper Preliminary Design	16
Taxonomy of Details.....	16
Physical Construction	19
Conditional Details: Post Cap.....	19
Model Display Stand.....	21
Digital Construction.....	25
Computer Modeling as Representation.....	25
Computer Modeling in Design.....	27
Digital Realization	27
Rapid Prototyping	27
Chapter 2: Analysis of Existing Inspirational Details	30
Washington D.C. Metro Inspired Details	30
Analysis of Existing Washington D.C. Metro Entrance Canopy Pin Joint	30
Computer Representation of Modified Pin Joint	33

Computer Animation for an Assembly Diagram	35
Physical Rapid Prototyping of Modified Pin Joint	36
Stadelhofen Railway Station, Zurich, Switzerland – Santiago Calatrava.....	37
A ‘Complete’ Project	37
Selected Works – James Cutler, Cutler Anderson Architects.....	44
A Different Take on a Design Process.....	44
Chapter 3: History and Important Facts Regarding the Proposed ‘Purple Line’ Light- Rail Public Transportation Initiative.....	50
History of the ‘Purple Line’ Initiative	50
Intended Routes	50
Planned Stations.....	50
Purple Line Light-Rail Initiative as a case study	52
Important Facts Concerning the ‘Purple Line’ and Light-Rail.....	53
Light-Rail System versus Metro System	53
Proposition Assumptions	54
Chapter 4: Cataloging of Required System Elements	56
Catalog of Worldwide Public Transportation Station Elements.....	56
Major Elements for Weather Protection and Shelter	56
Elements for Water Management and Drainage.....	58
Unseen Elements like Trash Collectors and HVAC Grilles	58
Signifying Elements.....	59
Lighting.....	59
Ramps and Accessible Elements	60
Track Crossings	61
Security Cameras and Other Protective Elements	61
Ticket or Other Fare Machines	62
Seating.....	62
Signage.....	63
Newspaper or Pamphlet Holders	64
Chapter 5: Initial Methods of Detail Design and Development	66
Taking Necessity for Implementation Towards a Design.....	66
Listing of Detail Elements that will be Explored.....	66
List of Basic Methods for Design Exploration	66
Design Detail Element 1: Generic Station Platform Canopy.....	67
Basic Design Considerations and Parameters.....	67
Preliminary Detail Sketching / Brainstorming.....	68
Digital Constructions	72
Digital Alternatives.....	77
Platform Scale Alternatives	80
Design Issues and Conclusions.....	82
Chapter 6: Refined Methods of Detail Design and Development	85
A Step Back to Analysis	85
A Reexamination of Station Stop Configurations and Train Cars.....	85
A Look at the Structural Forces at Play	87
Diagrammatic Responses to Structural Forces	89
Wood Based Station Stop Progression	94

Gestural Thoughts.....	94
Diagrammatic Progression.....	95
Conception or More Accurate Representation.....	97
Steel Based Station Stop Progression	100
Gestural Thoughts.....	100
Diagrammatic Progression.....	101
Conception or More Accurate Representation.....	103
One Material Chosen	105
For Uniformity of the System, Single Material Preferred	105
Elaboration of Steel Station Stops	106
Single Sided Stop Progression	106
Double Sided Stop Progression	121
Single Sided Small Stop Progression.....	129
Chapter 7: A New Kit-of-Parts Realized	132
Other Details for an Infrastructure Needed.....	132
List of Detail Elements that will be Explored.....	132
Details and Proportions to Allow for Expanded Design Opportunities.....	133
Structural Forces as a Diagram	133
Rules of Connection.....	134
Aesthetic Proportional Constraints	136
Wire Support Posts	139
Reasons for Implementation	139
Gestural to Diagrammatic	139
A More Accurate Conception	140
Signaling Options.....	143
Reasons for Implementation	143
Gestural to Diagrammatic	143
A More Accurate Conception	144
Trash or Recycle Bin	145
Reasons for Implementation	145
Gestural to Diagrammatic	146
A More Accurate Conception	147
All-Weather Chair.....	149
Reasons for Implementation	149
Gestural to Diagrammatic	150
A More Accurate Conception	151
Pamphlet Holder	154
Reasons for Implementation	154
Gestural to Diagrammatic	155
A More Accurate Conception	156
Hand and Guard Rails.....	159
Reasons for Implementation	159
Gestural to Diagrammatic	160
A More Accurate Conception	160
Way-finding Post and Clock.....	166
Reasons for Implementation	166

Gestural to Diagrammatic	167
A More Accurate Conception	168
Symbols and Iconography.....	171
Reasons for Implementation	171
Gestural to Diagrammatic	171
A More Accurate Conception	172
Additional Propositions	174
Conceptual Beginnings Not Developed to Realization	174
Chapter 8: Propositions for Implementation.....	176
Implementation of the Kit-of-Parts.....	176
Canopies First then the Sky's the Limit.....	176
Notes on Implementation of Materials	177
Material Finishes.....	177
Site Specific Implementation.....	177
Notes on Site Selection	177
Chapter 9: Commentary on Detail Design and Development in the Profession of Architecture	188
Historical Practices	188
How Things Used To Be Done.....	188
Current Practices.....	189
How Things Are Done Now	189
Proposed Practices	190
How Things Should Be Done	190
Chapter 10: Conclusions.....	192
Missed Opportunities.....	192
Full Scale Installations.....	192
Large Scale Material Studies	192
Detail versus Motif versus Style.....	193
Wording and Jargon.....	193
An Interesting Diagram.....	195
Abstraction versus Representation and Biomorphic versus Tectonic.....	195
Reversing the Process	196
Feasibility.....	196
Bibliography	198

List of Figures

Figure:	Page:
Figure: I-1 – Simonswerk Tectus concealed door hinge	1
Figure: I-2 – Heathrow Airport Terminal 5.	2
Figure: I-3 – Beijing National Stadium.	3
Figure: I-4 – Nicholas Grimshaw and Partners. London Waterloo Terminal. Structural truss detail.	4
Figure: I-5 – Nicholas Grimshaw and Partners. London Waterloo Terminal. Truss scaling diagram.	4
Figure: I-6 – Patkau Architects. La Petite Maison du Weekend.	5
<u>Figure: I-7 – Patkau Architects. Agosta House.</u>	<u>6</u>
Figure: 1-1 – Taxonomy of Details Leading to a Random Design Combination.	18
Figure: 1-2 – Hoboken, New Jersey Waterfront.	19
Figure: 1-3 – Four Conditional Post Cap Details.	20
Figure: 1-4 – Model Display Stand Version 1.	22
Figure: 1-5 – Model Display Stand Joint Improvements.	23
Figure: 1-6 – Model Display Stand Version 2.	24
Figure: 1-7 – Preliminary Detail Design Sketches.	25
Figure: 1-8 – Preliminary Computer Generated Details.	26
Figure: 1-9 – 3D-Printed ‘Double Clevis’ Joint.	28
<u>Figure: 1-10 – 3D-Printed ‘Complicated Pin’ Joint.</u>	<u>29</u>
Figure: 2-1 – Washington D.C. Metro Entrance Canopy (Clarendon Station).	30
Figure: 2-2 – Washington D.C. Metro Entrance Canopy Pin Joint Detail.	31
Figure: 2-3a – Washington D.C. Metro Entrance Canopy Structural Analysis.	32
Figure: 2-3b – Washington D.C. Metro Entrance Canopy Structural Analysis.	33
Figure: 2-4 – Entrance Canopy Pin Joint Detail Abstraction / Assembly Diagram.	34
Figure: 2-5 – Entrance Canopy Pin Joint Modified Detail Abstraction / Assembly Diagram.	34
Figure: 2-6 – Entrance Canopy Pin Joint Modified Detail Assembly Animation.	35
Figure: 2-7 – 3D-Printed Canopy Pin Joint Modified.	36
Figure: 2-8 – Stadelhofen Railway Station. Zurich, Switzerland. Aerial.	38
Figure: 2-9 – Stadelhofen Railway Station. Zurich, Switzerland. Watercolor Gestural Diagram.	39
Figure: 2-10 – Stadelhofen Railway Station. Column Detail.	41
Figure: 2-11 – Stadelhofen Railway Station. Analysis Sketches.	42
Figure: 2-12 – Stadelhofen Railway Station. Analysis Sketches.	43
Figure: 2-13 – Wright Guest House. Entry.	44
Figure: 2-14 – Bloedel Education Center. Pool Area Connection Details.	46
Figure: 2-15 – Bloedel Education Center. Living Room.	47
Figure: 2-16 – Cutler Anderson Analysis Sketches.	48
<u>Figure: 2-17 – Cutler Anderson Analysis Sketches II.</u>	<u>49</u>

List of Figures

Figure:	Page:
Figure: 3-1 –Proposed Washington D.C. Metro System Map including new Purple Line.	51
Figure: 3-2 – Proposed Purple Line Route Map.	52
Figure: 3-3 – Siemens S70 light-rail car used in Charlotte, N.C.	54
<u>Figure: 3-4 – Siemens S70 Constraints and proposed 4 bay structural station stop layout</u>	<u>55</u>
Figure: 4-1a –Vertical Weather Protection Systems.	57
Figure: 4-1b –Vertical Weather Protection Systems.	57
Figure: 4-2 – Nicely integrated water management systems for public transportation shelters	58
Figure: 4-3 – Nicely integrated signage and HVAC system, poorly integrated trash collection.	59
Figure: 4-4 – A collection of signifying iconic elements.	59
Figure: 4-5 – A Collection of Integrated Lighting Systems.	60
Figure: 4-6 – A collection of integrated ramps with varying success.	60
Figure: 4-7 – A few examples of track crossings.	61
Figure: 4-8 – Protective Elements.	61
Figure: 4-9 – A few examples of ticket dispensing machines.	62
Figure: 4-10 – A few examples of platform seating.	63
Figure: 4-11 – A few examples of station signage.	63
Figure: 4-12 – Two examples of current trends for ways to give out pamphlets.	64
<u>Figure: 4-13 – Entire Catalog Presentation of Platform Elements.</u>	<u>65</u>
Figure: 5-1 – Process diagrams showing primary reasons for shelter & track / platform configurations.	68
Figure: 5-2 – Process force diagram analysis of existing shelter designs.	69
Figure: 5-3a – Process sketches for canopy pivot joint, plan layouts, and column base details.	70
Figure: 5-3b – Process sketches for shelter roof attachment, fabric connections, and basic seating ideas.	72
Figure: 5-4 – Shelter 1.0 track side view.	74
Figure: 5-5 – Shelter 1.0 integrated seating elements.	75
Figure: 5-6 – Shelter 1.0 modular signage component.	76
Figure: 5-7 – Shelter 1.0 dynamic fabric connecting rigid bays.	77
Figure: 5-8 – Shelter 1.1 track side view.	78
Figure: 5-9 – Shelter 1.1 integrated seating elements.	78
Figure: 5-10 – Shelter 1.1 modular signage component.	79
Figure: 5-11 – Shelter 1.1 dynamic fabric connecting rigid bays.	79
Figure: 5-12 – Shelter 1.0s street side view.	80
Figure: 5-13 – Shelter 1.1s opened up street side view.	81
Figure: 5-14 – Shelter 1.0s frontal view.	81
<u>Figure: 5-15 – Shelter 1.1s detail of signage module alteration.</u>	<u>82</u>

List of Figures

Figure:	Page:
Figure: 6-1 – Process diagrams showing primary shelter & track / platform configurations.	85
Figure: 6-2 – Siemens S70 Constraints and proposed 4 bay structural station stop layout	86
Figure: 6-3 –Basic Structural Forces in a Cantilevering Roof Structure.	88
Figure: 6-4 –Major Force Lines to become Generators.	89
Figure: 6-5 –Force Resolution 1: Wood Based Stop Ideas.	91
Figure: 6-6 –Force Resolution 2: Steel Based Stop Ideas.	92
Figure: 6-7 –Force Resolution 2.5: Major Force Lines to become Generators.	93
Figure: 6-8 – Gestural Wood Based Crane Stop.	94
Figure: 6-9 – Diagrammatic Model – Wood Based Stop.	95
Figure: 6-10 – Diagrammatic Model – Wood Based Stop Detail.	95
Figure: 6-11 – Diagrammatic Model – Four Purlin-to-rafter Connections in Stand.	96
Figure: 6-12 – Diagrammatic Models – Four Purlin-to-rafter Connections.	97
Figure: 6-13 – Conception Model – Four Bay Wood Station Stop.	98
Figure: 6-14 – Conception Model – Four Bay Wood Station Stop Detail.	98
Figure: 6-15 – Gestural Model – Steel Roof Structure Diagram.	100
Figure: 6-16 – Gestural Model – Diminishing Roof Structure.	100
Figure: 6-17 – Diagrammatic Model – Roof Slice Attachment.	101
Figure: 6-18 – Diagrammatic Model – Roof Slice Attachment Detail.	102
Figure: 6-19 – Conceptual Sketch – Tripod Based Steel Stop Assembly.	103
Figure: 6-20 – 4 Bay Station Stop Model – Steel Construction.	104
Figure: 6-21 – 4 Bay Station Stop Model Detail.	104
Figure: 6-22 – Tripod Assembly Diagram.	107
Figure: 6-23 – Early Concealed Base-to-Ground Connection.	107
Figure: 6-24 – Refined Gestural Drawing of Simple Roof Slice.	108
Figure: 6-25 – Wrapped Roof Slice Configuration.	109
Figure: 6-26 – Wrapped Roof Slice Conceptual Model.	110
Figure: 6-27 – Wrapped Roof Slice Digital Model Incorporating Advanced Tripod, Signage Mounts, Integrated Seating Elements and Digital Readout Screens.	110
Figure: 6-28 – Wrapped Roof Slice Digital Model Incorporating Screen Printed Advertising.	111
Figure: 6-29 – Wrapped Roof Slice Digital Model Incorporating Topographic Mediating Seating Element and Organic Roof Slice Transformations.	112
Figure: 6-30 – Wrapped Roof Slice Digital Model Incorporating Topographic Mediating Seating Element and Other Modular Insertable Features such as Pamphlet Holder or Ticketing Machine.	112

List of Figures

Figure:	Page:
Figure: 6-31 – Final Single Sided Stop Elevation Showing Incorporated Display Mount, Wire Support Location, Tripod Zone Signage and Seating, Sleek Base Detail, and Organic Wrapping Roof Slice.	114
Figure: 6-32 – Roof Slice Variations and Assembly Procedures Diagram.	115
Figure: 6-33 – Tripod Column Sheet Templates for Water Jet Cutting.	116
Figure: 6-34 – Base-to-Ground Detail, Slice-to-Tube Detail, Tube-to-Column Detail.	118
Figure: 6-35 – Four Bay Final Single Sided Station Stop Plan and Front Elevation.	119
Figure: 6-36 – Final Single Sided Station Stop Perspective View.	119
Figure: 6-37 – Final Single Sided Station Stop Model Incorporating Slightly Older Means of Meeting the Ground with Topographic Mediating Seating Element, Including Rapidly Prototyped Tripods.	120
Figure: 6-38 – Final Single Sided Station Stop Model, Elevation View.	120
Figure: 6-39 – Final Single Sided Station Stop Model Detail View Showing Integral Signage Mounts and Morphing Wrapped Roof Slices Turned into Seating Elements.	121
Figure: 6-40 – Initial Conceptual Diagrams for Double Sided Stop.	122
Figure: 6-41 – Early Quadripod Assembly Diagram with Two Sided Seating and Integral Signage.	123
Figure: 6-42 – Final Quadripod Central Post Sheet-Cut Template, Tripod Leg Sheet-Cut Template.	123
Figure: 6-43 – Quadripod Final Assembly Diagram.	124
Figure: 6-44 – Double Sided Stop Force Diagram Generator Reminders.	124
Figure: 6-45 – Double Sided Stop Final Orthographic Representations.	125
Figure: 6-46 – Double Sided Stop Final Perspective View Incorporating Sleek Base-to-Ground Detail and 360 Degree Seating Elements.	126
Figure: 6-47 – Double Sided Stop Final Model, Aerial View.	126
Figure: 6-48 – Double Sided Stop Final Model, Elevation View.	127
Figure: 6-49 – Double Sided Stop Final Model, Roof Detail.	127
Figure: 6-50 – Double Sided Stop Final Model, Perspective View Incorporating 3D-Printed Quads.	128
Figure: 6-51 – Double Sided Stop Final Model, Perspective View.	128
Figure: 6-52 – Single Sided Small Stop Orthographic Representational Drawings.	130
<u>Figure: 6-53 – Single Sided Small Stop Perspective View.</u>	<u>131</u>

List of Figures

Figure:	Page:
Figure: 7-1 – Continuity of Structural Diagrams.	134
Figure: 7-2 – Aesthetic Constraints for Roof Slices.	137
Figure: 7-3 – Aesthetic Constraints for Columnar Assemblies.	138
Figure: 7-4 – Wire Support Post Gestural Diagram.	139
Figure: 7-5 – Wire Support Post Diagram.	140
Figure: 7-6 – Wire Support Post Orthographic Representation.	141
Figure: 7-7 – Wire Support Post Assembly Diagram.	141
Figure: 7-8 – Double Wire Support Post Orthographic Representation.	142
Figure: 7-9 – Double Wire Support Post Assembly Diagram.	142
Figure: 7-10 – Conceptual Signaling Option Sketches.	143
Figure: 7-11 – Signaling Option Examples.	145
Figure: 7-12 – Trash Bin Conceptual Sketches.	146
Figure: 7-13 – Trash Bin Diagrammatic Sketches.	147
Figure: 7-14 – Trash Bin Orthographic Representation.	148
Figure: 7-15 – Trash Bin Assembly Diagram.	148
Figure: 7-16 – Trash Bins Realized View.	149
Figure: 7-17 – Chair Conceptual Sketches.	150
Figure: 7-18 – Chair Diagrammatic Sketches.	150
Figure: 7-19 – Chair Orthographic Representation.	152
Figure: 7-20 – Chair Assembly Diagram.	152
Figure: 7-21 – Chair Realized View.	153
Figure: 7-22 – Chair Modular Options View.	153
Figure: 7-23 – Pamphlet Holder Conceptual Sketch.	154
Figure: 7-24 – Pamphlet Holder Developmental Sketches.	155
Figure: 7-25 – Pamphlet Holder Diagrammatic Sketches.	156
Figure: 7-26 – Pamphlet Holder Orthographic Representation.	157
Figure: 7-27 – Pamphlet Holder Assembly Diagram.	158
Figure: 7-28 – Pamphlet Holder Realized View.	158
Figure: 7-29 – Railing Conceptual Sketches.	159
Figure: 7-30 – Railing Diagrammatic Sketches.	160
Figure: 7-31 – Railing One Orthographic Representation.	161
Figure: 7-32 – Railing One Assembly Diagram.	162
Figure: 7-33 – Railing One Realized Views.	163
Figure: 7-34 – Railing Two Orthographic Representation.	164
Figure: 7-35 – Railing Two Assembly Diagram.	165
Figure: 7-36 – Railing Two Realized View.	166
Figure: 7-37 – Way-finding Post Conceptual Sketches.	167
Figure: 7-38 – Way-finding Post Orthographic Representation.	168
Figure: 7-39 – Way-finding Post Realized View.	169
Figure: 7-40 – Way-finding Post Assembly Diagram.	170
Figure: 7-41 – Way-finding Symbol Process.	171
Figure: 7-42 – Way-finding Symbol.	172
Figure: 7-43 – Unique Fastener Diagrammatic Sketches.	173
Figure: 7-44 – Small Shelter Conceptual Sketches.	174
<u>Figure: 7-45 – Small Shelter Orthographic Representation.</u>	<u>175</u>

List of Figures

Figure:	Page:
Figure: 8-1 – Proposed Track Lines Traversing Campus Drive.	179
Figure: 8-2 – Proposed Stop Locations at Existing Transportation Hub Near Student Union.	180
Figure: 8-3 – Schematic Orientation Aerial for Conceptual Animations Showing Station Stop Configuration of One Double-Sided and One Single Sided Stop Flanking Campus Drive.	180
Figure: 8-4 – Campus Drive Stop Proposed View Looking Southwest	181
Figure: 8-5 – Campus Drive Stop Proposed View Looking West	181
Figure: 8-6 – Campus Drive Stop Proposed View Looking East	182
Figure: 8-7 – Proposed Track Lines Traversing South Campus.	183
Figure: 8-8 – Proposed Stop Locations Near Preinkert Hall.	183
Figure: 8-9 – Proposed Site Modifications Near Preinkert Hall Station Stop.	184
Figure: 8-10 – Proposed Site Section Through Preinkert Hall Station Stop.	184
Figure: 8-11 – Schematic Orientation Aerial for Conceptual Animations Showing Station Stop Configuration of Two Mirrored Single Sided Stops Flanking Mowatt Lane.	186
Figure: 8-12 – Preinkert Hall Stop Proposed View Looking Southeast	186
Figure: 8-13 – Preinkert Hall Stop Proposed View Looking West	187
<u>Figure: 8-14 – Preinkert Hall Stop Proposed View Looking Southwest</u>	<u>187</u>
<u>Figure: 10-1 – Positioning Mentor Architects' Methodologies Diagram.</u>	<u>195</u>

Introduction

Inspiration

Details

Structurally expressive tectonic architectural details spurred the initial investigation for the development of this thesis proposition. After experiencing these details first hand by visitation, or otherwise experiencing them in lectures, books, or journals, a need for a deeper level of understanding arose. A fascination for all levels and scales of details began to develop. Anything from a concealed, prefabricated, brushed, steel door hinge, to a massive pin joint forming the base to a gigantic, tapering, steel column fifteen feet in circumference, have furthered exploration into this type of architecture.

Figure: I-1 – Simonswerk Tectus concealed door hinge. Accessed 11.08.08 <www.index-d.com>.



Figure: I-2 – Heathrow Airport Terminal 5. Designed by Richard Rogers Partnership. Structural column to roof and curtain wall detail. Personal photo taken May 2008.

Firms and Buildings

The 2008 summer Olympic Games in Beijing, China, cast architecture in the forefront of the World's view. Certain buildings have made lasting impressions on our society. Venues such as the 'Bird's Nest' (Beijing National) Stadium, designed by Herzog and de Meuron, and engineered by Arup, have turned what was once only remotely imagined architecture into a structurally expressive reality.

Figure: I-3 – Beijing National Stadium. Elevation. Accessed 11.08.08 <http://ist-socrates.berkeley.edu/~kppeng/images/Beijing_National_Stadium.jpg>.

Many firms are implementing uniquely new design interventions, systems, and processes unheard of in the field even ten years ago. Firms like Nicholas Grimshaw and Partners are using the most recent and advanced building technology in their designs and their close attention to structural systems and expressive engineering have put them at the forefront of introductory research. Their use of digital media in

the design process is very unique and will be a point of exploration in certain areas of detail development. A direct association and collaboration with this firm during a recent comprehensive design studio experience showed just how presently influential this firm is within the field with regards to parametric computational design.

Figure: I-4 – Nicholas Grimshaw and Partners. London Waterloo Terminal. Structural truss detail.
Accessed 11.08.08 <www.grimshaw-architects.com>.

Figure: I-5 – Nicholas Grimshaw and Partners. London Waterloo Terminal. Truss scaling diagram.
Kolarevic 19.

On a smaller scale of structurally expressive design, firms like Patkau Architects have designed small explorative pavilions, and even small scale residences that incorporate an incredible attention to expressive detail throughout, whether structural or ornamental. This design development towards a more complete and unified architectural experience for projected users is intriguing and something that can hopefully be approached by the work of this proposition.

Figure: I-6 – Patkau Architects. La Petite Maison du Weekend. Accessed 11.08.08 <www.patkau.ca>.

Figure: I-7 – Patkau Architects. Agosta House. Accessed 11.08.08 <www.patkau.ca>.

Goals

Reversing the Design Process and the Legitimacy of this Proposition

Through a process of precedent research, precedent analysis, and detail design and development, this thesis will attempt to prove that even the smallest element can in fact inspire an entire system of architectural interpretation. Although not fully reversing the process due to lack of constraints and conditional necessity, specific site and programmatic issues will be kept to a minimum until the last possible moment in design. More focus will remain on the procedural qualities of detail development in specific instances versus that of a typically overarching design problem. After the completion of the design and research of this proposition, conclusions will be made

regarding the legitimacy of performing such a process in the present day architectural profession.

Exploration of New Detail Design Methods

Methods of design in the architecture world have remained roughly the same for the last hundred years. Only recently have cutting edge architecture firms pushed past the pen-paper-analog method and moved into more digital means of design. Now, this is not to say that the architectural world has not begun to embrace the era of computing and put these machines to a very beneficial use in the design process, but typically these machines have simply become tools that can make representing ideas faster. Only a few firms, Nicholas Grimshaw and Partners included, have begun to really use the computer and put digital design possibilities to the test. Through means of parametric design, where variables and constraints are introduced to establish boundaries, limits, restraints, or mandatory conditions, Grimshaw has been able to insert informational values into a computer and let the mathematical and computational simulations produce a design. This is of course a simplistic version of this process but more importantly, it is up to the firm to determine if this output has any value. Nevertheless the computer is being used as a design tool at the forefront of the process, not simply as a faster way of drafting and representing final designs.

This proposition would also like to look at these computational design methodologies and evaluate their role in the design of architectural minutia. Conventional methods for developing parts such as hands-on modeling will be employed. Simultaneously digital means will be used to explore methods of iteration and unrestrained aesthetic

fine tuning. Additionally, digital models will be employed to test the newer methods of digital fabrication and rapid prototyping (three dimensional printing). These new technologies are very powerful and can quickly realize almost any architectural interpretation of just about anything. As well, with digital fabrication sitting at the forefront of sustainable building practice, methods may be explored that can potentially improve the construction efficiency of more modern and technologically advanced architectural details.

Development of a Kit-of-Parts

An end goal of this process would be to establish a kit-of-parts that could be implemented along with the construction of the new ‘purple line’ light-rail initiative. This system of parts would be comprised of easily reproducible architectural detail elements that could be used in a variety of locations and conditions. Versions would be developed for different site-specific characteristics, but the general system of architectural details would ideally be used for all stations along this line of transit. This would help distinguish these stations or platforms from other modes of existing public transportation and employ a more modern approach to take advantage of newer and more advanced construction systems and technologies.

Evaluation of the Current Profession with Regard to Detail Development

Lastly steps will be taken to evaluate how the profession has changed with regard to the issues surrounding constructional details. Long ago, architects used to have a very important relationship with the skilled craftsman that built a project. They were very aware of how to cut a stone or to even otherwise attach one material to the next in order to complete a building. Now details are ‘figured out’ within an office and

many designers will never even visit a project for which they have ‘worked out the details.’ After the schematic design stages of a project are complete, details will be formed during the design development and construction document phases. Many firms however simply reuse details from other projects that might be close to the intent of the new design. Details are drawn either for purposes of basic project coordination (between all disciplines – for example structural and civil engineering, to landscaping or mechanical and electrical design) or to provide for basic liability. The architect assumes a level of expertise when drawing these details. They later may be altered and modified by element fabricators or sub-contractors working on a project by the completion of shop drawings, but the detail creation process occurs later in the typical architectural design process. Creativity in these areas usually falls short because of time constraints and other issues. By reexamining the role of architects with regards to detail creation, this proposition hopes to encourage a more active role in their creation and development. As well, other professions could be bypassed if the architects had a more direct role in their creation. The ‘shop drawing’ stage could almost be eliminated if architects were more educated on the structural implications and the intricacies of the digital fabrication processes and how it related to their newly computer-generated detail designs. Certainly this would require another discussion about responsible party liability and other legal issues but that is not an aim of this proposition.

Major Issues to Investigate

Notion of 'Craft'

Issues of craft have always been professed at all levels of design education. It is one thing to develop a design through abstract models and messy drawings. However, the clearer the intent of the methods used, the easier it is to communicate ideas to others. Craft in all methods of representation should be enforced as any type of design is developed. Specifically in the case of this proposition, two major issues regarding craft will be explored. A high level of craft in physical model production, and within digital design environments will equally be pursued. Digital craft on one end will be an interesting exploration as the computer can be used to design through the input of parameters, variables, and constraints. This type of craft will occur after the digital generation of output with iterative selective processes. This is in direct opposition to the particular type of craft that must take place when physically modeling that is employed constantly as construction and development occur.

Notion of 'Scale'

Scale has always been an interesting topic with regards to architecture. Some finished buildings become objects of ridicule when they appear 'scale-less.' They may or may not have been designed with that intent, but certain elements, or lack thereof, can spark anxiety in visitors and general confusion to people who come in contact with these buildings on a daily basis. Juxtaposed with that, many buildings can feel 'comfortable' when designed with elements that relate back to a 'human scale.' What are these elements in question? Other buildings may embody a colossal or monumental scale, but as long as these ideas of scale are communicated well, most

people are accepting of the outcomes. Which is preferred in design? Either method for designing with regards to scale has been declared successful in architecture. Can details designed to be touched and interacted with on a daily basis become more pleasing to a human experience of architecture? Can this attention to detail design inform the general public more about the intention of a designer? This issue of relating things, including architecture, back to a human scale has been a topic of discussion of the most important architects of our time. From Le Corbusier relating his architecture to his 'Modular Man', to even further back in time to Leonardo da Vinci's 'Vitruvian Man,' scale has always been an issue of discussion. With the design of these details, this will be no exception.

Notion of 'Materiality'

Architecture in a sense is all about materials. Material has to be used to complete architecture. Nothing is made without material. Things can be designed material-less, but to actually see if something will be feasible, material constraints will have to be assigned. Details may first be designed without regard to materiality to test simply aesthetic aspirations while other methods will employ physical, structural tests of materiality. The inherent properties in a material itself may also provide clues towards potential methods of joinery and certainly architectural form. Details will also be designed by simply improvising with the hands-on construction of different materials. Material will play a large role in the final outcome of many of these infrastructural implementations.

Notion of 'Didactic Architecture'

Can people learn more about architecture through the experience of architecture?
Can people learn something totally unrelated to architecture through the experience of architecture? This thesis will also attempt to inspire education through the development of detail systems in the designs for these architectural implementations. Ideally, if the architecture is interesting and captivating enough, people who experience it will become excited. There might be visual cues to process one through a building or a site. There could be simple digital readouts detailing information on solar gain from photovoltaic panels. One might trace the structural members supporting a protective structure and determine the forces acting on a tectonically expressive joint. Whichever method employed, there is something to gain by designing with didactic intent. The more people that can be touched by architecture, the better off the profession will be. It should be the goal of every designer to not just give something back to a community, but help them to learn something new, or at least to feel good about the bus stop that appeared overnight in their neighborhood.

Notion of 'Sustainability'

Emerging construction techniques and design practices are finally approaching more sustainable ideology. Specifically through the use of local materials in design, more efficient managing of construction sites, and a general means to stay environmentally friendly, architectural practices are gaining large ground with regards to becoming more 'green.' New technology has even more directly impacted sustainable practice in architecture. With the advent of solar panels, geothermal heat pumps, wind turbines, or even bio-diesel, we are slowly but surely transforming our culture to an

eco-conscious society. In detail design, continuing to develop sustainable practices of prefabrication, material consciousness, and methods for easy assembly, disassembly, and reuse of elements, we can begin to push the limits of this type practice. This proposition will try to pursue these ideals and employ advanced and efficient fabrication systems while simultaneously exploring greener materials to use in detail design.

Putting Ideas into Action

Preliminary Detail Development

At first, details will be developed independently of all outside influences. This brief exercise will focus on simple aesthetic qualities of designed details with only a hint of external conditional restraints. This will be a simple study to experience quickly the array of technology at the disposal of the school, and explore new methods for using this array of technology. There will be a brief discussion concerning the value of this exercise at the conclusions of the chapter.

Analysis of Existing Inspirational Details

Due a lack of understanding of some of the constraint-less details that were generated within the first section of this proposition, new methods must be employed to further productivity as time moves along. A return to some of the inspirational details found at the forefront of this proposition will allow for some much needed educational insight as to the ‘reason for being’ of the specific design of these details. Analysis will be conducted to determine how structural forces work in certain details, and basically will be done to determine why they came out the way they did. Most of

these details will be found to look the way they do for very specific reasons, and the value of initial external constraints or inputs will be tested.

History and Intent of the 'Purple Line' System

A study will be conducted to catalogue the array of important information concerning the proposed 'Purple Line' light-rail system. Basic site analysis will be pursued with regards to the actual routes of the line, station locations, planned track configurations, and potential discrepancies within this initiative proposition. Reasons for implementation of this new system will be touched upon, but more important architectural necessities will be discovered for actual implementation of this public transportation system.

Cataloguing and Analysis of Required System Elements

This 'Purple Line' system will require many details to function properly and effectively as a highly beneficial public transportation system. Many features of station and platform design will be researched and catalogued so further detail design and development can begin. Everything from the main structural canopies and shelters, down to the places to sit or simply deposit trash will be catalogued. These required elements for a functioning system will push this proposition into the next step and design of a new system of required elements will be developed to signify this new initiative.

Initial and Refined Methods of Detail Design and Development and a Kit-of-Parts

Many methods for design of these details will be explored. Beginning with simple hands-on construction techniques, details will be created. As well, simultaneous

means of design will take place with digital technology. Using digital means as a method of virtual representation will be undertaken, yet further methods of parametric design and digital processes will also be encouraged. Many scales of details will be developed. Using principles of iterative design, small scale models will be created and many layers of drawing will help to gain quick understanding of a wide array of necessary details. Later, larger scale tests will begin to uncover material constraints and limitations of these designs, as well as more realistic tests with regards to weather protection, light and physical interaction. Finally full scale installations may be attempted to foresee the reality of these design implementations.

Propositions for Implementation

Due to situations developed by public transportation systems, any new implementation of a platform, canopy, or sign, has to be quickly built and installed in order to maintain the functionality of the system. However, with the ‘Purple Line’ being a new installation, major infrastructure will not be an issue. However, if steps arise to deal with revamping the existing conditions, with regards to street-side stops, platforms, or station elements, strategies will have to be explored to impose timely implementation. This is where current practices of digital prefabrication could be of great use. Methods for detail design that would be supportive of prefabrication would surely be preferred with regards to installation in a public transportation system. In a place where time is of the essence, anything that can be mass produced and easily assembled will be preferred.

Chapter 1: Preliminary Detail Development

Pencil to Paper Preliminary Design

Taxonomy of Details

For a beginning to an arbitrary procedural process, a method of designing details without regard to physical constraints was initiated. A taxonomy of details was developed and by a process of randomization, small details would be combined to form a schematic possibility for the design of a building system. Six random ‘joints’ found in typical building design were chosen for exploration. These consisted of connections from roof-to-roof, column-to-roof, frame-to-skin, column-to-frame, foundation-to-column, and foundation-to-earth. Then six random details were drawn and assigned to each category. Then a number was assigned to these details, and after a few die rolls, six random details (one from each category) were chosen to attempt to create a cohesive design.

This may have seemed like a feasible design process in the beginning; however after attempting to combine un-like details into one design became problematic. For example, a steel space frame style detail was chosen to create a column-to-roof connection, but a wooden ridge beam was chosen as a roof-to-roof connection. These systems of details would not usually be found together in a design and in this case there was no exception.

An extremely schematic structural system was derived that combined a slab on grade foundation-to-earth connection, a concrete base directly bolted to steel column foundation-to-column connection, a clip-style column-to-frame connection, a metal frame to storefront curtain wall frame-to-skin connection, a space frame column-to-roof connection, and again, the ridge beam to wooden rafter roof-to-roof connection. In this case, the space frame system would create a dropped ceiling element while the wooden roof structure could provide for some variation in a pitched roofing system. The rest of the details combined fairly easily, but either way, creating overkill in a possible structural design layout.

In examining this method of detail combination, it proved to be questionably effective. This would probably not happen in a real design. If this exercise were performed again by only choosing one material for detail design, for example, wood beam/columns/rafters with possibly metal connecting plates/joints/etc., there may be more conclusions to draw. The combination of endless material possibilities here proved to be less than effective. Different systems of design using the same material may additionally provide for some interesting randomized combinations. In the end, those may be more feasible, and that style of randomized design within some base material conditional restraints also may work well. This particular taxonomy was simply not extensive enough, and basically more open-ended than originally desired.

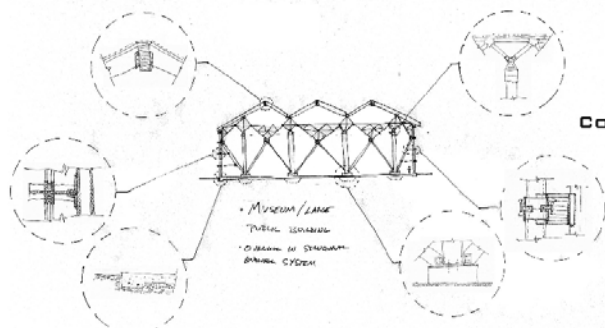
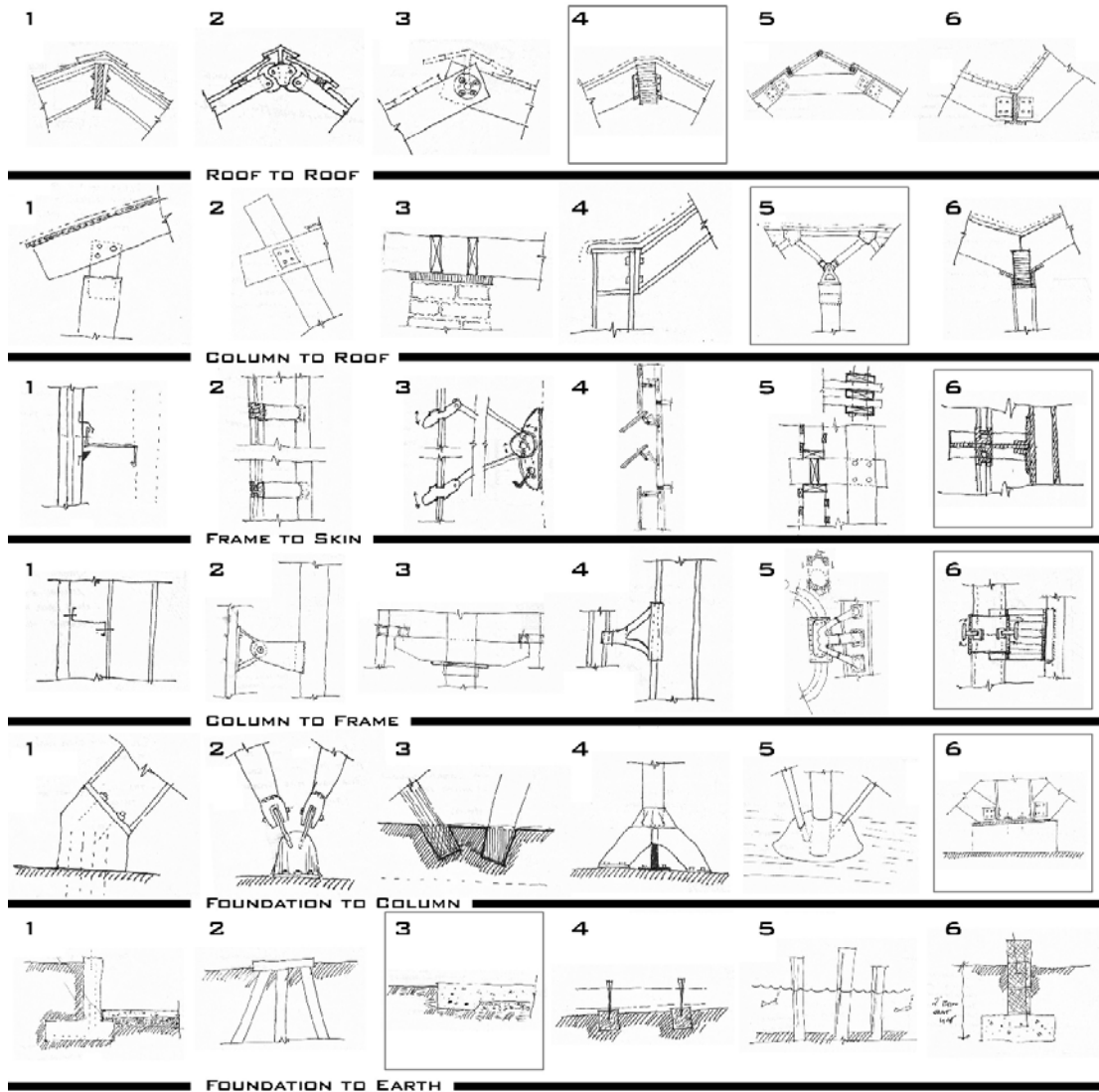

CODE FOR DESIGN: 366654

TAXONOMY
 ZAK SCHOOLEY_THESIS MEETING AT_10.20.08

Figure: 1-1 – Taxonomy of Details Leading to a Random Design Combination.

Physical Construction

Conditional Details: Post Cap

Another method for creating details will put one constraint on the process, that being, in this case one conditional location and one desired resultant outcome. After randomly seeing a field of abandoned dock pilings off the coast of Hoboken, New Jersey, a condition was found. Details would be created to sit on top of these wooden piles, which vary in height and form a unique texture in the water. Now, there will be no correspondence between these details, but they will be again taken simply as a study of aesthetic detail creation while attempting to ignore potential outside influencing forces of supporting a generic floor deck.

Figure: 1-2 – Hoboken, New Jersey Waterfront. Google Earth Image, Accessed 10.01.08.

The method of choice for representing and experimenting with these details will be small scale physical models. Here also, there will be simple hints of materiality, but

the primary bonding agent will be glue so as to ignore any specific constraints materials might bring in this situation.



Figure: 1-3 – Four Conditional Post Cap Details.

In the end, four details were tested, all using a different system of attachment to sit on the theoretical posts. One convenient result of this testing of details would be that these ‘post caps’ could be used on any type of resulting design situation using posts. They would not have to be positioned over these exact piers in this New Jersey

waterfront, but could later be attached to concrete piles in beach front locations, or even cut tree trunks in forested locations. Yet, a lack of understanding about the specific nature of how these materials function may still lead to a less than feasible detail construction system. However, aesthetic intentions proved to form four different ‘partis’ for these joints and could later be used, when specific locations arose, to influence a further system of more specific conditional details supported by structural calculations.

It would be interesting to return to a taxonomic structure here and try combining these post cap details. However, as before, with implied differences in materiality, there might not be effective conclusions to be found.

Model Display Stand

A later step in this design process entailed working with actual materials in full scale during a hands-on setting. Originally intending to construct a series of joints at a larger scale than before in order to enact some strength of material testing, a need for a structurally expressive base to display, simultaneously developing digitally-created rapidly-prototyped models arose. This model base would prove to be a useful tool in this process. By using found materials, improvisation in design was explored.

By taking these found pieces of metal and wood, methods were derived for joining the two materials together. After construction however, it was obvious that more education in specific component joinery would be needed to fully understand these details that were constructed. The model stand acting as a joint for displaying other

models proved to be a very helpful means for design. There was only one constraint and it was fairly open ended. Models needed to be displayed, so a larger model was made to display them.



Figure: 1-4 – Model Display Stand Version 1.

Another iteration of this model stand was pursued after production of a later 3D-printed joint. The major stand arrangement stayed the same, but a more rigid connection would be needed to connect the wooden masses at the top of the base to the metal door frame at the base. Once this later model was mounted on top of the stand, the entire base grew a tendency to wobble. The decreased stability near the top of this base created some unsettling nerves with regards to model longevity. Some specifically cut wood braces were applied to the joint between the aluminum risers, and the metal door frame. Pressure was needed to keep an 'L' shaped metal angle piece that was welded to the frame from moving. Once these braces were applied, rigidity was improved drastically. Steps were then taken to remount the other joints on the remainder of the stand.

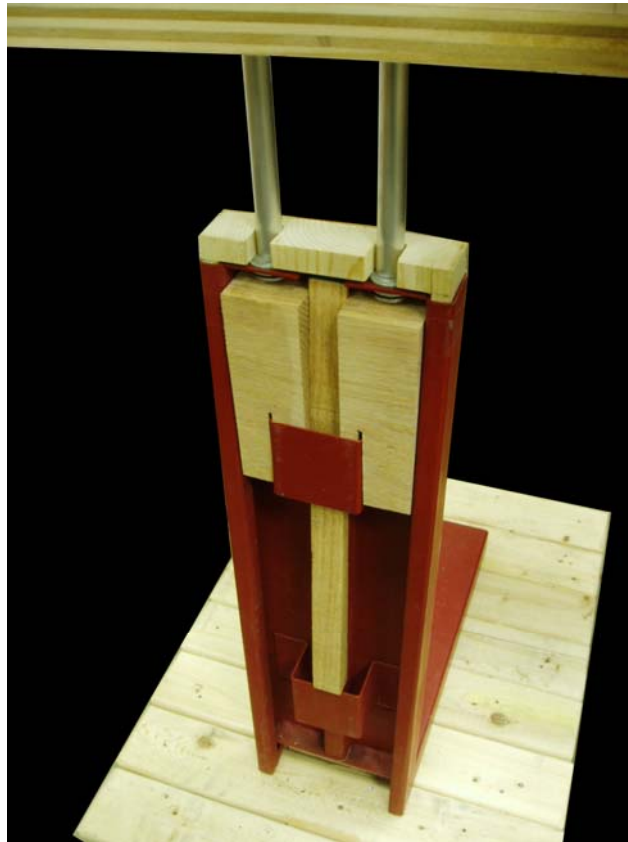

Figure: 1-5 – Model Display Stand Joint Improvements.



Figure: 1-6 – Model Display Stand Version 2.

Digital Construction

Computer Modeling as Representation

Concurrently with the model stand being designed, some computer animated three dimensional modeling was taking place. Again, with primarily aesthetic concerns flourishing, the computer was simply used as a tool for representation of idealized designs that started from sketchbook based hand drawings. The joints that were first created here had very minimal constraints and no material designation. There may have been some inspiration from the London, Heathrow Terminal Five, building's massive pin joints, and some Grimshaw-inspired cable-stayed tensile structures, but the joints were created to see how basic computer modeling could be employed.

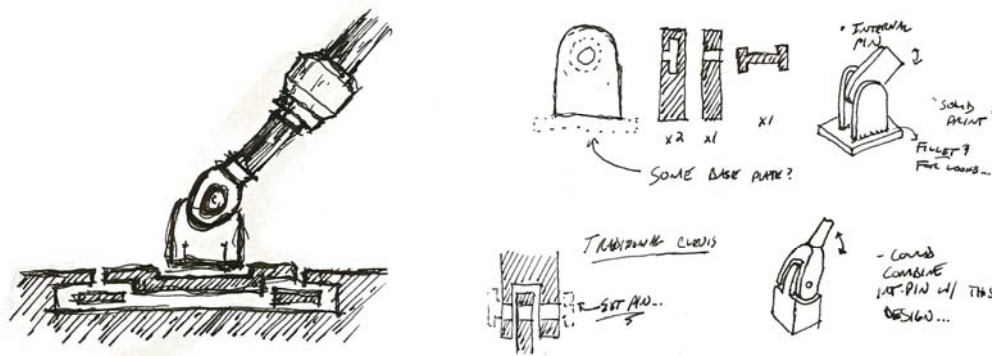

Figure: 1-7 – Preliminary Detail Design Sketches.

The only slightly bounding factor with the design of these details was a potential physical size that may have had the ability to later be 3D-Printed (rapid prototyping). In the end, this became a possibility and later sections will discuss this technology. Through the design of a few details, this technology could be pushed to its limits and proved to be very exciting.

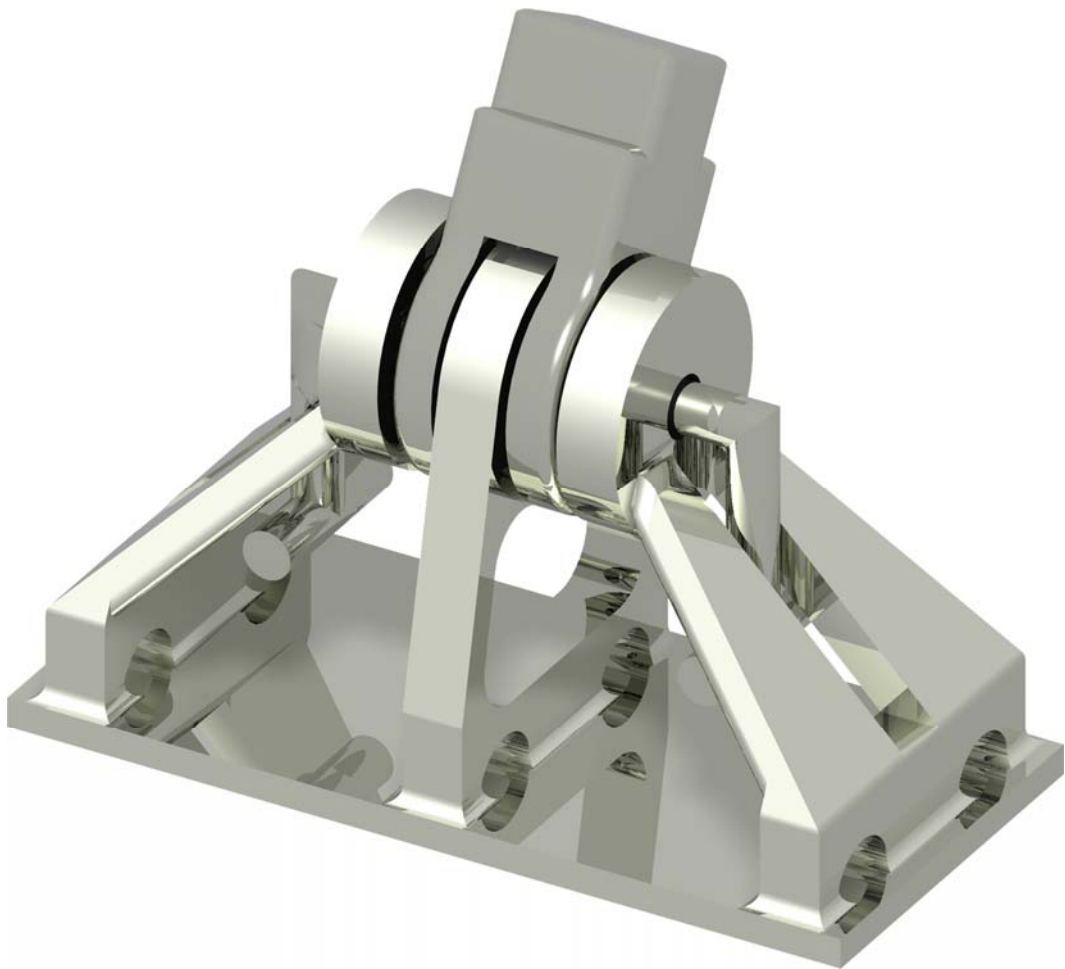
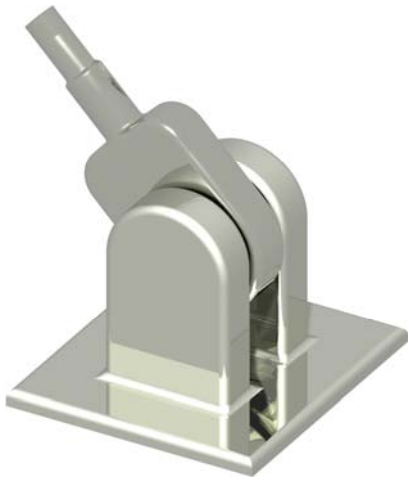

Figure: 1-8 – Preliminary Computer Generated Details.

Computer Modeling in Design

For these preliminary investigations attempts have not yet been made to use the computer as the unique design tool it has the potential to be. However it is interesting to note, that because of constraints for the size of these objects for later 3D-Printing, certain digital constraints were established, parameters if you will. Now, these parameters were not used with an algorithmic based system of design modifications to develop a set of versioned pieces, but were rather a simple group of guidelines to design around. The maximum size for one object to be rapidly prototyped would be an 8" x 8" x 10" volume. Therefore, the details that were computer generated fit into this three dimensional box. However different methods were used with this technology to produce drastically varying results.

Digital Realization

Rapid Prototyping

After designing these few specific details for implementation into the 3D-Printer, two very different methods for obtaining a final result were used. In one case, for the 'double-clevis with a base and pins' element, the model was printed with five separate pieces which would then be assembled like a puzzle after the printing was complete. The other detail however, which looks like a slightly larger, slightly more complicated pin joint, was printed completely assembled. Both of these details pivot, rotate, and function as one would expect, but both take advantage of different ways this type of technology can be used. In reality however, a completely printed, wholly

assembled and working metallic pin joint would probably not be the most efficient way to use this technology. The time required alone is fairly staggering. We can trace the assemblage of parts however back to Ford's assembly lines, when the efficiency in fabrication reigned supreme.



Figure: 1-9 – 3D-Printed 'Double Clevis' Joint.

This technology can be used in very interesting ways unlike any other type of three dimensionally modeling equipment. Even Computer Numerically Controlled routers (CNC Routers) have to start with a large block of material and generally 'subtract' material to yield a result. Because of how the 3D-Printer operates, it 'builds up' material and suspends the model to be produced in excess material. More uses of this technology and material system will be used throughout this proposition to test more complicated designs both with complete assemblages, and by producing a multitude of parts that can later be assembled. Intricate three dimensional designs can be quickly implemented with this technology, with the minimally annoying production

size constraint (an 8"x8"x10" maximum volume can be 3d-printed with the available machine).

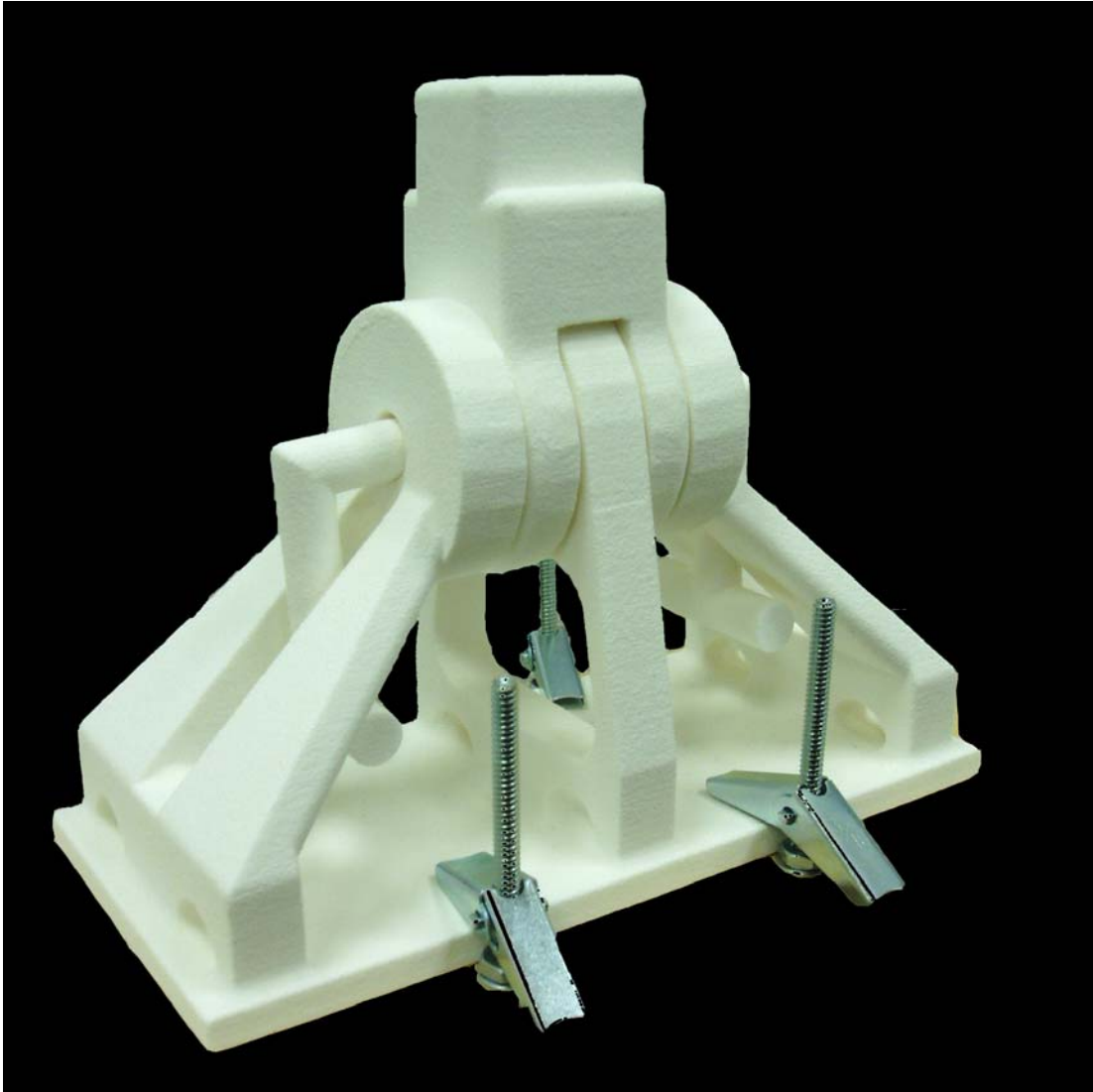

Figure: 1-10 – 3D-Printed ‘Complicated Pin’ Joint.

Chapter 2: Analysis of Existing Inspirational Details

Washington D.C. Metro Inspired Details

Analysis of Existing Washington D.C. Metro Entrance Canopy Pin Joint

After beginning detail design without any regard to outside influences, a change had to be made. A more thorough analysis of existing details that have been under precedent consideration would need to be performed. A lack of understanding of how the previously designed details would actually function was hindering their success. The next step would be to choose a detail, in this case a pin joint helping to support a Washington, D.C. metro entrance canopy, and return to earlier structural educational knowledge to examine its reason for being.



Figure: 2-1 – Washington D.C. Metro Entrance Canopy (Clarendon Station). Personal Photo 10.20.08.



Figure: 2-2 – Washington D.C. Metro Entrance Canopy Pin Joint Detail. Personal Photo 10.20.08.

The following analysis was conducted to determine the reasons for the aesthetic qualities of this joint in relation to the functional nature of transferring gravitational forces from the weight of the canopy down into the supportive masonry platform.

This conditional detail had to solve two major problems upon its conception. The masonry clad barrier was an existing implement to protect bystanders from falling down the hole made by the escalators that led to the underground metro station platform. A canopy had to be created to protect travelers, along with the escalator mechanical infrastructure, from weather. Now, this canopy could have been simply a roof supported by four vertical columns at the four corners of that horizontal surface. Yet rain needed to be shed from the shelter, and a more iconic entry image for the metro was desired. This led to the curving, slanting, glass and metal canopy that we see today with its angular columns as supports.

The following analysis showed how forces could be transferred from the ends of this canopy down through the angled columns and directly down into the masonry support

base. The pin joints used here proved to be a good choice for transferring angular resultant loads from opposing columnar supports to a vertical gravitational force which ends up being resisted by that masonry base. To keep all of the force vectors centered within the entire system, a detail had to be created to get the steel columns centerlines to coincide. This was created by a tapered clevis system and by shaving off part of the steel column near this pin joint. These details provide for a smooth and sleek system that works very efficiently to support this canopy.

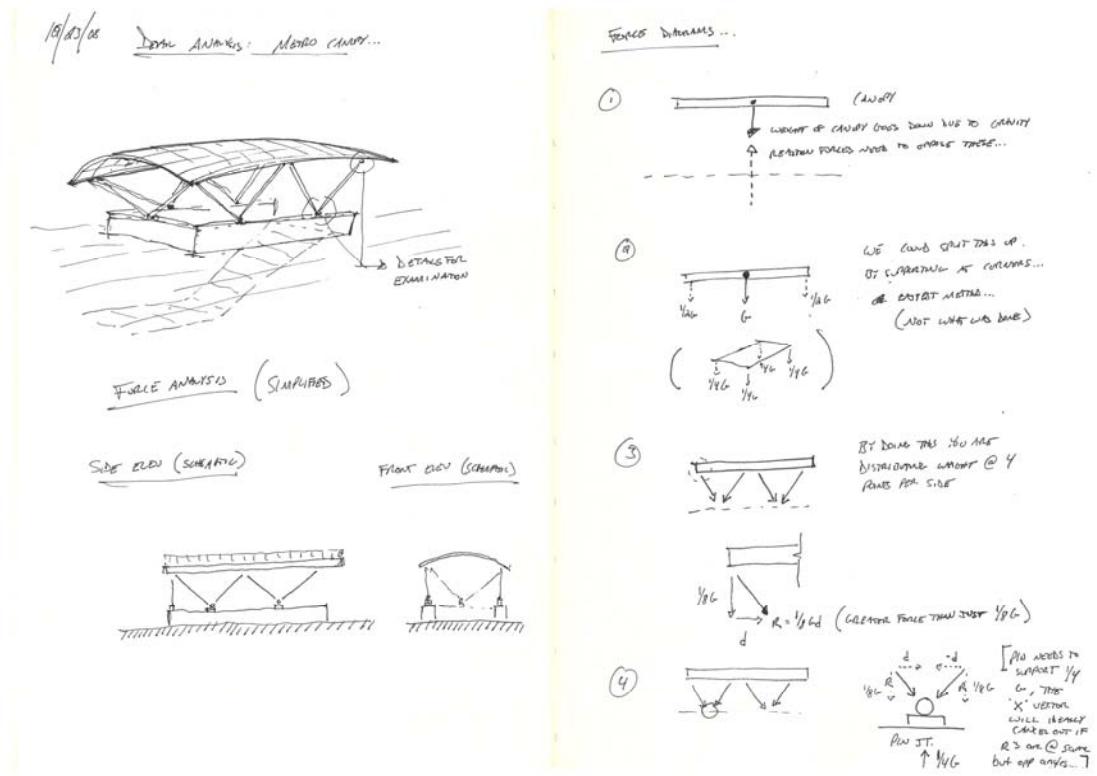

Figure: 2-3a – Washington D.C. Metro Entrance Canopy Structural Analysis.

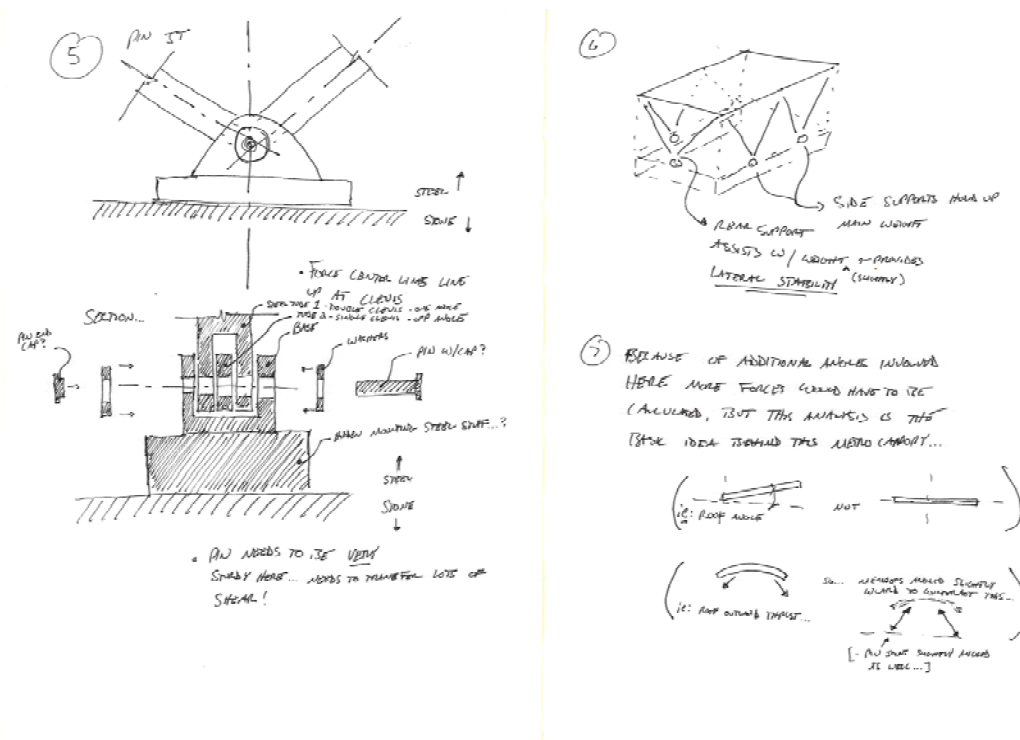

Figure: 2-3b – Washington D.C. Metro Entrance Canopy Structural Analysis.

Computer Representation of Modified Pin Joint

After analyzing the metro canopy pin joint, the design of a modified joint would take place. This new pin joint was designed using digital visualization and generation simultaneously with hand-drawn design. A modified base design was employed in an attempt to divert the potential torsion and shear forces in such a system. The first design was modified later to incorporate an even wider base and adding more attachment pins to increase stability. The column ends (shown here simply as a generic system which could be interpreted as a metal end to a wooden column, an entirely metal column, etc.), would have different end conditions, one male and one female, so they could interlock and freely rotate about the axial pin that connects them back to the base. A pin was created that would fully run through all column ends and base supports, yet would contain a secret inner locking system so both pin

ends would appear flush. This was also a secret in the examined existing metro canopy pin joint. The joinery was concealed to create, again, a more sleek detail situation.

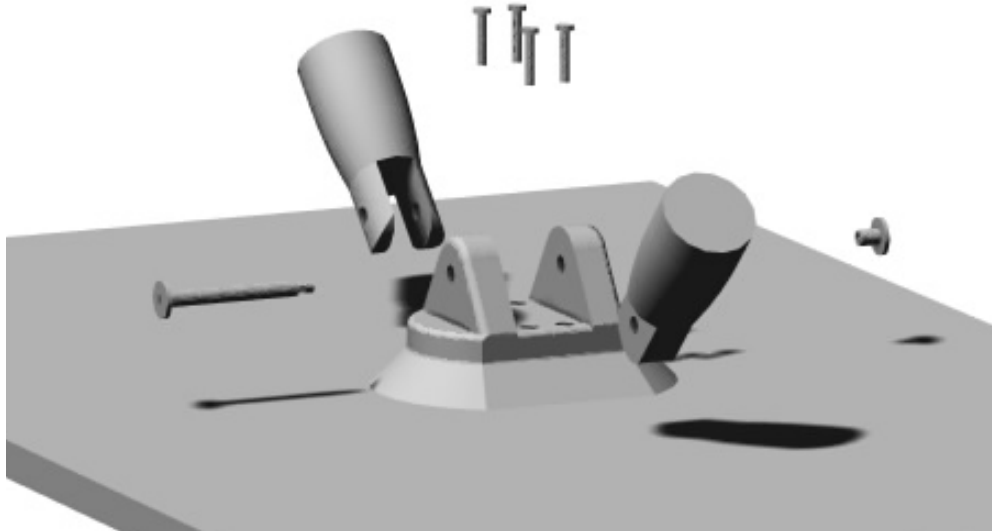

Figure: 2-4 –Entrance Canopy Pin Joint Detail Abstraction / Assembly Diagram.

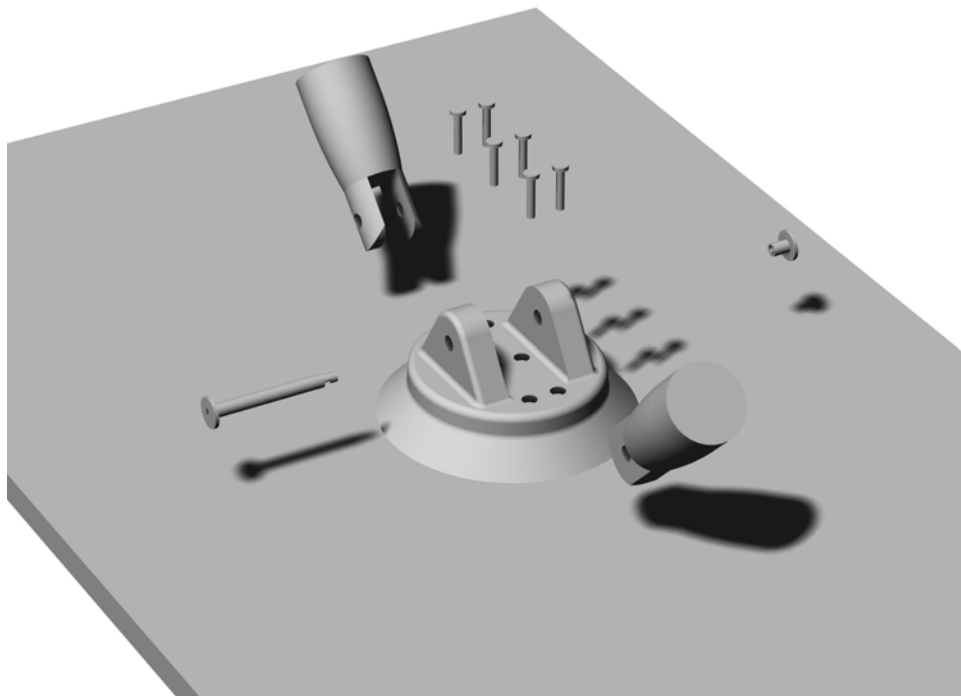

Figure: 2-5 –Entrance Canopy Pin Joint Modified Detail Abstraction / Assembly Diagram.

Computer Animation for an Assembly Diagram

As more digital technology can be embraced along a design process, new means for describing increasingly complicated systems can be employed. After creating a digital model for this pin joint system, steps were taken to animate the assembly process. This method for describing systems is almost as good as having a real, life-size model in your hands to interpret for yourself. With these types of digital means, even the most complicated detail assemblies can be quickly described in a simple fashion that would normally take many sets of detail drawings. More usage of this computer animation technology will be employed along this process for explanation of the detail systems that will be created.

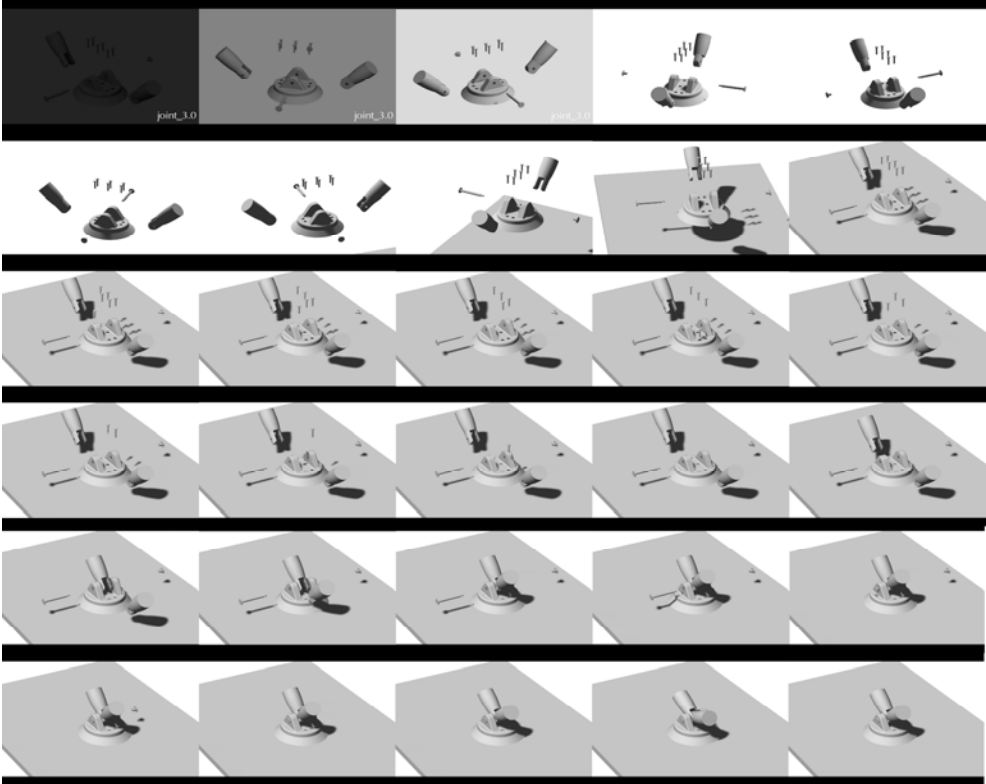

Figure: 2-6 –Entrance Canopy Pin Joint Modified Detail Assembly Animation.

Physical Rapid Prototyping of Modified Pin Joint

As with the original details, this digital model would be printed three dimensionally. Some issues arose with this rapid prototype however. Up to this point in this proposition, this joint detail is the largest, and could feasibly be a full scale representation of an actual connection. However large this connection was, the pin and inner-locking pin cap did not come out quite as expected. Even though tolerances were digitally modeled into the design of these connectors, the designed locking mechanism would not quite fit into the pin cap. After these models are produced, they need to be sealed with water as to let the outer layer of glued powder harden and fully set. In more fine areas of these models this sprayed water can create essentially bubbling on the surface. Inside the pin cap, this was no exception. That forced an unsuccessful attempt at sanding and filing down regions to get the cap to fit on the end of the pin.



Figure: 2-7 – 3D-Printed Canopy Pin Joint Modified.

After this final set of three dimensionally printed models was complete, a few things have been determined. Even though this technology is great for visualizing accurate representations of potentially complicated digital models, it is not quite as accurate as one might like. Because of this procedural method of spray-setting the pieces, variances will occur and a desired level of minute exactness is simply not realistic. Still, this is a great technology and can be very helpful for realizing advanced designs and acting as an intermediate method for interaction of architects and digital fabricators. By using this technology, coupled with assembly animations or other digital diagrams, an architect could extremely accurately convey his or her design intentions to a fabricator, contractor, or consultant. Options are endless with this machine but creative means will be necessary for the rapid production of anything larger than the 8" x 8" x 10" bounding box of the machine's output region. One would need to create models in such was to have interlocking pieces, or again, creating a physical kit-of-parts for assembly of a larger system.

Stadelhofen Railway Station, Zurich, Switzerland – Santiago Calatrava

A 'Complete' Project

At different stages in this process of developing details, constant research was done to analyze existing works of architecture to see how the notion of detail was handled. In this instance of an early work in the career of Santiago Calatrava, this train station in Zurich proved to be an interesting example of how one can keep a similar theme of design employed through many aspects of a project.

The goal of this project was basically to provide shelter for new tracks while addressing issues of circulation across this relatively urban site. What came about was a very tectonic and exciting system of shelters and elements for directing circulation that take on unique forms while appearing in a variety of materials and scales. The entire station, from the overarching supporting structure of concrete, down to the steel elements supporting simple but elegant roof structures, and finally to the station signage, this design motif of details addresses the overall parti of the project, while addressing many different scales of interaction.

Figure: 2-8 – Stadelhofen Railway Station. Zurich, Switzerland. Aerial. Santiago Calatrava (Tzonis).

One can see the grand gestural moves Calatrava made, after beginning with a watercolor painting that addressed the simple ideas of shelter and connection, in the large and swooping concrete forms that support a roadway and large crossing. Later one can see how the gestural becomes more developed when architectural and structural forces meet in the design of a stairway and pedestrian bridge. Finally a set

of coordinating elements form the language of a group of railings and an overhead set of steel signage mounts as well as mounts for the wires that power the trains.

Figure: 2-9 – Stadelhofen Railway Station. Zurich, Switzerland. Watercolor Gestural Diagram. Santiago Calatrava (Tzonis).

After analyzing many of these coordinating details a few major ideas and points of consideration emerged. Issues of contrast seem to maintain importance in much of this work. For lighter, steel, structural elements to stand out, they tend to be juxtaposed with more massive stone, or concrete elements. This tends to over-emphasize the lightness of some of these sheltering structures. Additionally variety in connection seems to be a point of interest for Calatrava. In some cases, one can tell that the structural conditions became the foundation for the type of connection employed in some of these details. For example, due to rotational forces on a cantilevering roof structure, a tubular element was used in combination with a bolted

plate connection to resist a structural moment condition. This specific detail will be explored later during investigations regarding proposed proposition roof structures. In other conditions however, concrete elements simply touch the ground in anthropomorphic fashion. Concrete columnar elements resolving primarily gravity loads barely touch the ground in almost an invisible structural resolution. The only notion of detail is a slight extension at the base of the column becoming almost a 'foot' to the structure. What must be an enormous network of reinforcing steel and hidden bolts or other supporting structure is enclosed to appear simple and lightweight.

Later in the design many other elements emerge that coincide with a later notion of cataloguing of public transportation system elements. Items such as mounts for clocks, station signage, stair tread mounts, and incorporated drainage systems, become points of departure for Calatrava to explore a variety of detail conditions. All of these details however could be seen as derivations from some of his original gestural drawings concerning the project. The way concrete is used throughout the project tends to differ based on the exact use and situation; the same could be said for how he uses steel. Additionally when these two materials touch, other conditions arise. He addresses each artfully and intricately and his innovative practices can be studied at length for an even deeper understanding. This desire for exploration into the completeness of this project is certainly a goal of this proposition as design development moves forward. One can almost learn how steel operates by analyzing details in this project. As well, one can learn how concrete acts differently. Finally,

one can see how these materials might interact at a variety of differing conditions. This project embodies the essence of what a 'complete' architecture could be, and for one of Calatrava's early projects, shows how masterful his career would become.

Figure: 2-10 – Stadelhofen Railway Station. Column Detail. Santiago Calatrava (Tzonis).

A final notion emerges from the analysis of this work by Calatrava. His design approach and methodology truly stems from art. He typically starts with either

biomorphic or anthropomorphic studies, and explores how certain forms and diagrams may lead to works of architecture. Based on these studies, his work inherently embodies ideas about proportion and scale. If the overall themes are related to a human at the grand scale, it is easy to relate these ideas down to the scale of a handrail for example. He abstracts human activity and elegance into a form of art, which is then figured out and made concrete by architecture. Simply art as a basis for architecture. This methodology for a design process is quite different to that of other architects, as a later analysis will show.

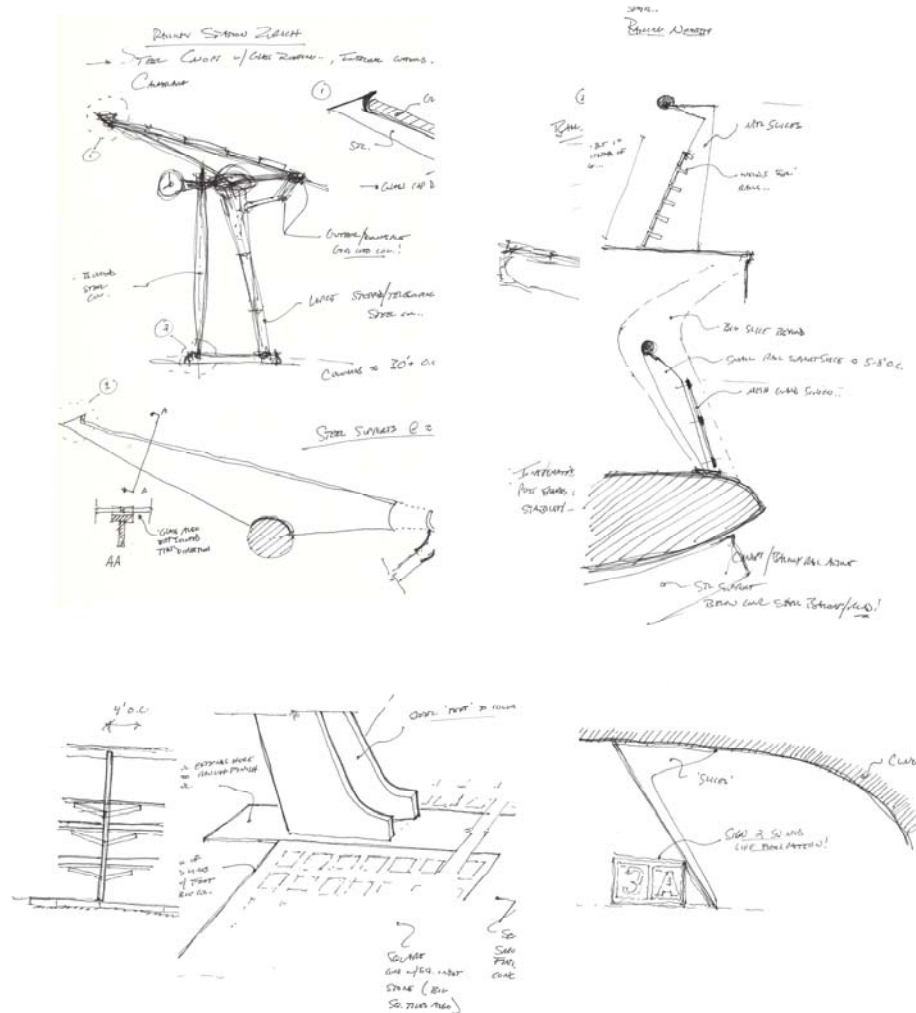

Figure: 2-11 – Stadelhofen Railway Station. Analysis Sketches.

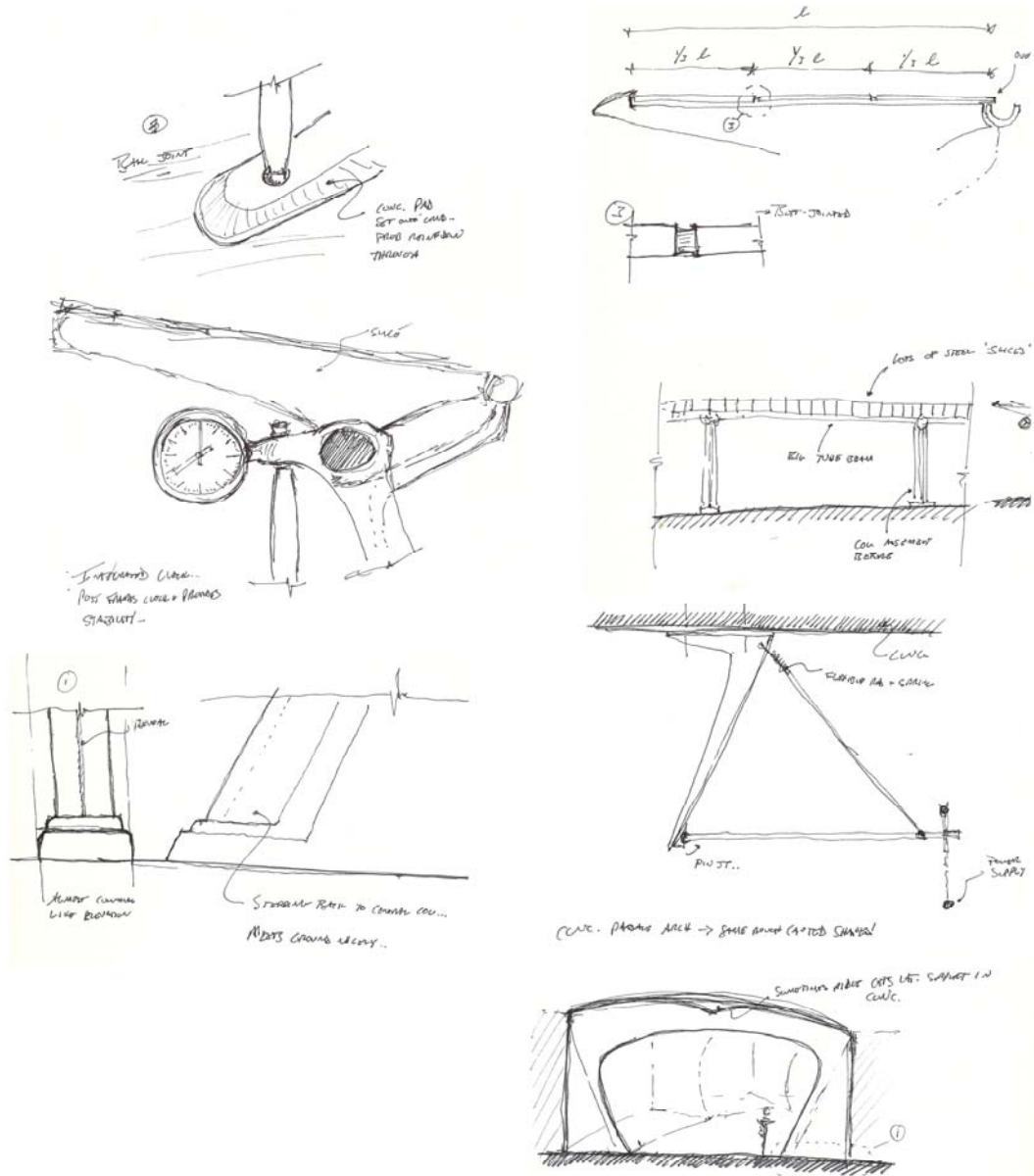

Figure: 2-12 – Stadelhofen Railway Station. Analysis Sketches.

Selected Works – James Cutler, Cutler Anderson Architects

A Different Take on a Design Process

Another firm that takes care when designing detail for a project is the one led by James Cutler, Cutler Anderson Architects. This firm takes a very different approach to design as compared with Calatrava. Here a typical design process is used, starting with a given site, program, and problems. Solutions are presented using a selected range of materials, typically local wood-based products, many of which take shape near Seattle, Washington where the firm resides. These materials however, originally used and conceived based on structural necessity, are joined in artful and masterful fashions.

Figure: 2-13 – Wright Guest House. Entry. Cutler Anderson. (Kennedy).

Cutler Andersen makes each joint a place for architectural expression. Ideas of basic resolution of structural forces are obvious, but the way a connection is carried out shows how simple, yet elegant, means can be articulated. Their use of steel as a mediator between like, and unlike materials shows how versatile this metal can be. Using ordinary post-and-beam construction, these steel connectors become a place of architectural mastery and high craftsmanship. Although appearing simplistic, these sometimes over-articulated connectors can be very complicated in actuality, constantly blurring the line between function and aesthetic. The plethora of inventive details used by this firm are worthy of analysis.

In projects like the Wright Guest House, and the Bloedel Education Center, the firm employs a variety of steel connections that solve a variety of simple tectonic conditions. However, at each situation, the detail is crafted in a way to make each instance stand out and become a point of contemplation. One is forced to stop at each connection and examine why the steel is shaped the way it is, or to notice each square-headed bolt conveniently oriented to ninety degrees.

A certain notion of sustainability is observed by this firm as well. Apart from the fact that many of the materials used are local to their projects, a level of structural member efficiency is observed. When larger member are needed, smaller units are strapped together. This of course creates room for another type of detail to be constructed and expressed. Craft is taken at all connections to show, mostly, how these projects would have been constructed. There are a few tricks however that are employed,

which can be seen in some of the construction document type axonometric drawings shown later, to make sure these connections will last (for example, hidden knife plates, or threaded metal tubes to penetrate the wood members and become bolt housings). For the most part though, this firm simply takes the stance that one can understand the tectonics of a building. It seems that the firm believes that joinery is an art in itself, and one that should be celebrated. These projects could have been built in many different fashions, ones much simpler, and ones perhaps less monetarily costly. However, one would surely receive a sense of educational benefit and a fuller experience by visiting one of these projects.

Figure: 2-14 – Bloedel Education Center. Pool Area Connection Details. Cutler Anderson. (Kennedy). Also important about this firm is how they relate their chosen language to their entire designs. It seems that when design choices are made, they are thoughtfully carried out over the course of an entire project. If a choice that the connection between wood and concrete will be steel, this joint will be carried out similarly throughout a project. Now, each contextual situation might intuit a different type of metal joint, but

throughout a design this language choice will be exhibited. As well, if metal strapping is used in creating a dialogue between stone surfaces and wooden members, or when larger wooden members are needed and smaller ones are held together, this technique will also appear in smaller instances of this condition. In one case, a wooden mantle is held together by metal strapping attached to a stone fireplace. This language is continued out to roof rafters, and even a bridged railing system in the entry to the project.

Figure: 2-15 – Bloedel Education Center. Living Room. Cutler Anderson. (Kennedy).

The level of craft is amazing throughout these details, but the continuity in design methodology while still allowing for architectural variety is most impressive. They take on a single style, or approach, but explore seemingly endless ways to enact their ideas. Sometimes these are based on specific conditional situations, but others simply when variety in design is desired. This is an approach to be admired and one that could become an interesting basis for a system of detail design.

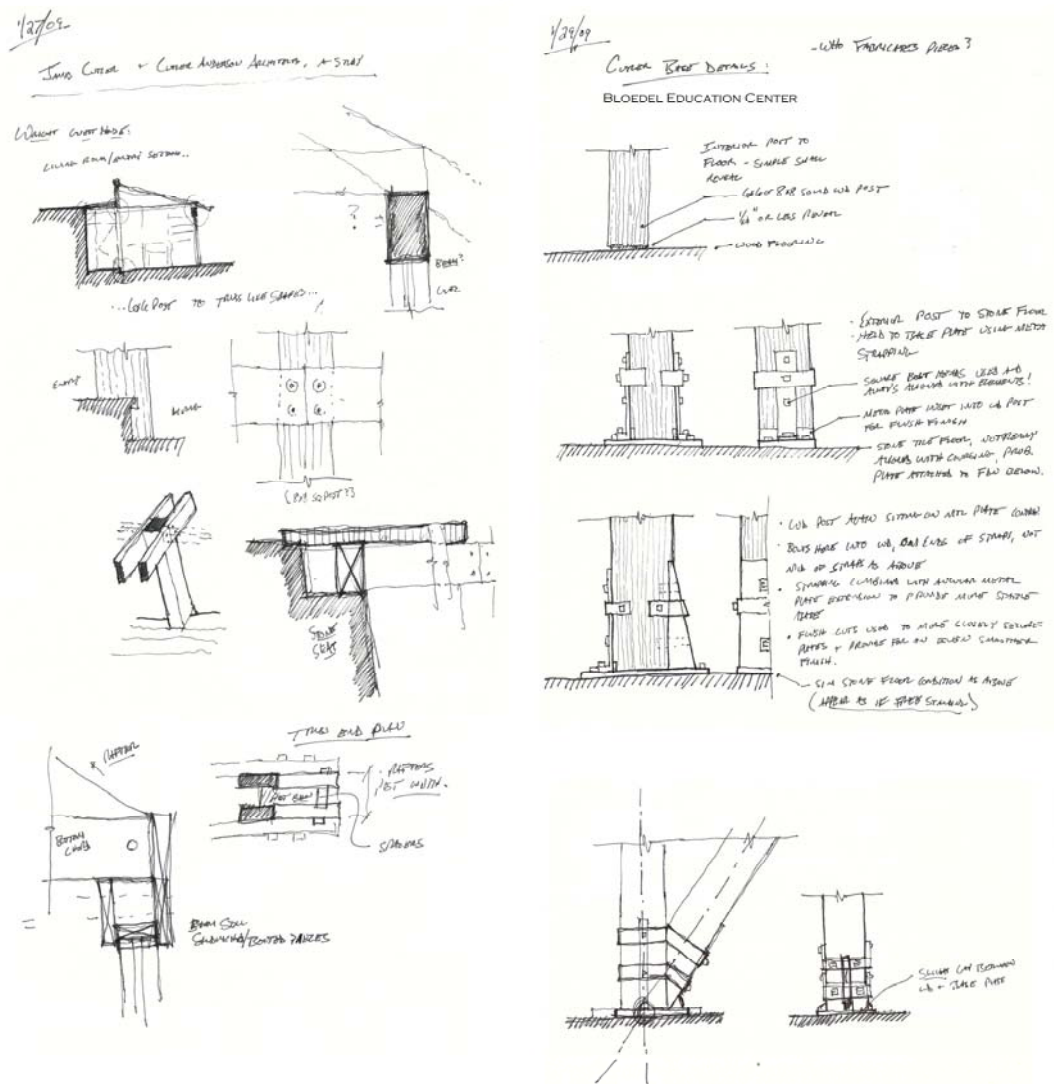

Figure: 2-16 – Cutler Anderson Analysis Sketches.

Chapter 3: History and Important Facts Regarding the Proposed 'Purple Line' Light-Rail Public Transportation Initiative

History of the 'Purple Line' Initiative

Intended Routes

The currently proposed 'Purple Line' route running inside the Washington, D.C. beltway would be implemented to connect New Carrollton, MD to Bethesda, MD by a quicker and more efficient public transportation system. The mode for this transportation route is currently planned to be either a light-rail or bus rapid-transit system. For the purposes of this proposition, the implementations will be designed assuming the light-rail system will be pursued. This route would drastically save commuters' time from having to enter the city in order to reach outer urban and suburban areas. Ideally the purple line would remove a large portion of automobile traffic from the ever congested beltway region that would basically be traveling along this same directional route.

Planned Stations

As one can see from the diagram below, the planned purple line route would run through a variety of urban and residential areas. This line would terminate at large currently existing metro stations (Bethesda and New Carrollton Stations). As well, this system route would pass through two other current highly trafficked stations at College Park, MD, and Silver Spring, MD. Between those four stops, eight other

station stops would be created. These would vary in scale and in their necessary infrastructural requirements depending on their specific location.

Figure: 3-1 –Proposed Washington D.C. Metro System Map including new Purple Line. Accessed 10.01.08 <<http://www.smartergrowth.net/anx/img/category/136/purple-line.gif>>.

Opposition to this transportation route has stemmed from the potential for drastic implementation of infrastructure at a few of these intermediate stops. For example, with a stop lying within the University of Maryland campus and others in currently upper class residential areas such as Chevy Chase, MD many people have objected to

this type of transportation network interfering with their typically undisturbed environment.

A more detailed map is shown below showing specific streets that will contain tracks (in the case of light-rail) in a shared right-of-way system, or be the direction of associated parallel new right-of-way areas for the new public transportation system, whether bus-rapid-transit or light-rail. This, still somewhat diagrammatic, map also shows alternative route configurations but tends to give a better sense of where the routes would actually run with regards to physical influence.

Figure: 3-2 – Proposed Purple Line Route Map. Accessed 10.01.08
<http://www.purplelinemd.com/images/stories/zoom_maps/alignment_alts_120408/alignment_alts_120408.swf>.

Purple Line Light-Rail Initiative as a case study

The goal here is not to assess the validity of using a light rail system versus a bus rapid-transit system, versus an underground metro rail system for this line (which has been an additional alternative proposal). Also this proposition will not show a preference to exactly where these particular station stops will be located however general site-specific constraints may be explored based on the suggested station stop

areas from the provided detailed route maps. Later, elements necessary for a public transportation infrastructural system will be catalogued and will become the basis for a kit-of-parts to be developed. These details and set of specific design guidelines will then form the basis and opportunity for others to continue to develop the infrastructure for the entire purple line system.

Important Facts Concerning the 'Purple Line' and Light-Rail

Light-Rail System versus Metro System

A few things should be said concerning this type of public transportation system. A light-rail system is different from the typical heavy-rail system that characterizes the majority of the Washington D.C. Metro that many may be more familiar with. The type of light rail that is being considered for this line does not necessarily have to have its own right of way like a heavy-rail system. In fact, this proposition will assume that the light-rail tracks will maintain a shared right-of-way with existing traffic. This will allow this proposition to ignore major changes to planned stop sites to incorporate a new right-of-way.

There are also differing power requirements for these two types of rail systems. Typically, as seen in the Washington D.C. Metro, the power is provided to the trains in an along-the-ground 'third rail.' This third rail is inaccessible to pedestrians as the track for this rail system is blocked off in an entirely closed right-of-way system. The power system for the light-rail trains that this proposition will be exploring, employ overhead wires, which will have to be hung on either poles or other suspending

structures as the trains move along. A *pantograph* is attached to the top of the train cars, and is a constantly height-adjusting device that makes contact with those above-ground wires to power the train. Details may be explored to provide support for this type of power system.

Proposition Assumptions

The type of specific train car used here will also be drastically different than those found in heavy-rail. Instead of entering the car about three feet off of the ground on raised station platforms, these light-rail cars can be entered on a slightly raised curb condition from those typically existing all over cities today (about 8" above grade). More specifically the light-rail car that will be assumed for use in this proposition will be a Siemens S70 low-floor access model. This specific light-rail train car, currently being used in Charlotte, North Carolina is a sleek, elegant, and modern train car that could be a desirable addition to this metropolitan area. This train car has specific, important clearance information that will be shown in following diagrams. This clearance information will be used to generate boundaries and constraints for station stop designs.

Figure: 3-3 – Siemens S70 light-rail car used in Charlotte, N.C.
<http://i.ehow.com/images/GlobalPhoto/Articles/2238011/LYNXCar104atTremontStation-main_Full.jpg>.

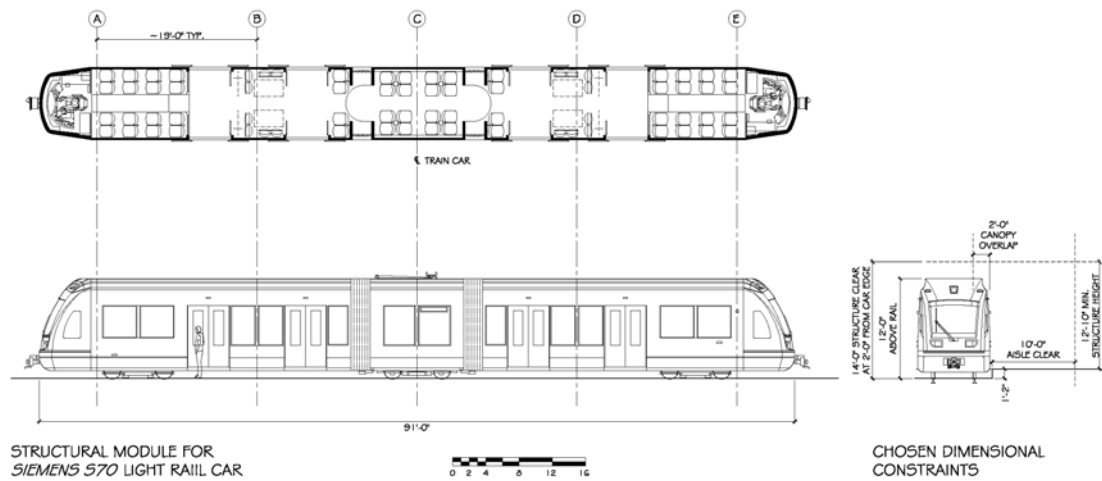

Figure: 3-4 – Siemens S70 Constraints and proposed 4 bay structural station stop layout

Light-rail typically operates along fairly straight runs of tracks, only making tight turns where absolutely necessary. There is also a maximum operation grade change of 7% so in most circumstances the tracks will be relatively level. At station stops however, for accessibility and egress into and out of cars, platform areas will be very close to level, as well as straight. The stations stops that will be designed will assume these restraints as well in order to avoid extremely sloping station stops, or curved station stops.

The Power supply wires incorporate complicated systems of weights and balances in order to keep them at a fairly uniform height along the route lines. There may be details developed to propose generic placement of these wire support systems, but actual attachment will be ignored. This type of attachment system would require additional time with specific utility consultants and is beyond the scope of this thesis.

Chapter 4: Cataloging of Required System Elements

Catalog of Worldwide Public Transportation Station Elements

Major Elements for Weather Protection and Shelter

Public transportation system station platforms have a few major elements that would need to be explored at a comprehensive level in order to see some results from this proposition. The first being the basic shelter, canopy, roof, or general weather protecting element of the station or stop. This element also has the daunting task of becoming the iconographic element for the transportation system. A good shelter design can provide for a comfortable place to wait, while at the same time encourage travelers to ride on public transportation. These shelters can become landmarks in a city, nodes for people to meet, and can either make or break the affect of the stations at a personal level. If the station stops are not visually appealing, or prove to be breeding grounds for questionable activity, then the public's interest in public transportation will diminish. The development of the architectural detail of these elements will be most important in creating an image for the Purple Line.

Figure: 4-1a –Vertical Weather Protection Systems. From Upper Left Clockwise: Melbourne, Australia; Houston, TX; Ireland; New Jersey; Sacramento, CA; Stadtbahn, Germany; New York Avenue Station, Washington, D.C. Accessed 11.20.08. Various Sources (Google Images & Flickr.com).

Figure: 4-1b –Vertical Weather Protection Systems. From Top Clockwise: Melbourne, Australia; Oregon; Clarendon, Washington, D.C.; Clarendon, Washington, D.C.; Salt Lake City, Utah. Accessed 11.20.08. Various Sources (Google Images & Flickr.com).

Elements for Water Management and Drainage

Even simple things like gutters and downspouts need to be considered when designing these relatively simple shelters. If careful consideration is not taken with regards to these crucial infrastructural elements, afterthoughts of poorly placed downspouts can ruin a design. Many found examples have illustrated how this integration can be done properly, but nonetheless this detail in precipitation management will be an area of study.

Figure: 4-2 – Nicely integrated water management systems for public transportation shelters. From Left: Minneapolis, MN; Charlotte, NC; Charlotte, NC. Accessed 11.20.08. Various Sources (Google Images & Flickr.com).

Unseen Elements like Trash Collectors and HVAC Grilles

Some major elements in public transportation networks typically remain undersigned and placed at the last minute. Again, if careful consideration is not taken, many elements like trash cans or recycling bins can really ruin ones experience while traveling on public transportation. If these areas are not easily cleaned or maintained, refuse can easily pile up, overflow, and create a noxious environment. Ideally, these collectors could be designed into a system of architecture whereby integral into the overall design of the platform or station elements, and were things that could be in themselves easily accessible for exchange or general clean up. Larger systems elements that are very crucial to large station designs would be HVAC implements.

However depending on the scope of the subsequent designs, these elements may not be necessary.

Figure: 4-3 – Nicely integrated signage and HVAC system, poorly integrated trash collection. Both images from Washington D.C. Metro system. Accessed 11.20.08. Various Sources (Google Images & Flickr.com).

Signifying Elements

Although the main shelter is usually the most iconic and signifying element in the public transportation network, other elements can sometimes help to signify the stations, platforms, or other nodes in the system. Research will be done to determine what elements could again give image and distinction to the proposed Purple Line.

Figure: 4-4 – A collection of signifying iconic elements. From Left: Charlotte, NC; Phoenix, AZ; India; Denver, CO; Los Angeles, CA; Charlotte, NC. Accessed 11.20.08. Various Sources (Google Images & Flickr.com).

Lighting

Lighting will be a significant design consideration. Lighting can be integrated very nicely into the design of these stops, or it could be a cheap afterthought. This

proposition will examine how detail in creative lighting can help foster a safer while more beautiful environment.

Figure: 4-5 – A Collection of Integrated Lighting Systems.
From Left: Denver, CO; Washington, D.C. bus stop details; Julie Snow’s proposed light rail stations for Minneapolis, MN. Accessed 11.20.08. Various Sources (Google Images, Flickr.com, & www.juliesnowarchitects.com).

Ramps and Accessible Elements

In the case of raised light-rail car design, elements would be required to get everyone off of grade and have the ability to access these cars. Ramps would typically be the most easily developed and integrated elements, but lifts or other electronic or mechanical devices could be incorporated. Accessibility is a major issue with regards to public transportation and already a few places have successfully solved this problem.

Figure: 4-6 – A collection of integrated ramps with varying success.
From Left Clockwise: Baltimore, MD; Sacramento, CA; Dallas, TX.
Accessed 11.20.08. Various Sources (Google Images, Flickr.com).

Track Crossings

In areas where pedestrians, sometimes handicapped, may have to cross actual light-rail tracks, implements must be incorporated for their swift and easy crossing. Again, the reality of the necessity for these types of elements will vary depending on final station and platform locations, but incorporation will be considered.

Figure: 4-7 – A few examples of track crossings.
From Left: Houston, TX; San Jose, CA.
Accessed 11.20.08. Various Sources (Google Images, Flickr.com).

Security Cameras and Other Protective Elements

With security always a concern nowadays, ways to thoughtfully integrate these systems should be undertaken from the beginning. Too many times have cameras been installed after the fact with little regard for the intent of a designer. These systems can and should be integrated into a station platform and more thoughtful ways of doing so will be explored

Figure: 4-8 – Protective Elements.
From Left: New York City Subway; Random Undisclosed Stop.
Accessed 11.20.08. Various Sources (Google Images, Flickr.com).

Ticket or Other Fare Machines

While not a high priority in this proposition, ticketing elements will not be designed. However, places to modularly incorporate such elements will be considered. Spaces for these types of elements, along with trash cans, vending machines, storage, etc. will be accounted for, but not necessarily elaborated upon. Places for these machines may be suggested, but the reality of a total integration of a station platform with these elements would be unlikely however desired.

Figure: 4-9 – A few examples of ticket dispensing machines.
From Left: Salt Lake City, UT; Other U.S. Stop.
Accessed 11.20.08. Various Sources (Google Images, Flickr.com).

Seating

Places for travelers to sit and rest before or between journeys will be a crucial element for design development in this proposition. Ways to incorporate seating into the shelter design itself, or to otherwise use seating to improve the feel or image of a station will be greatly explored. Certain issues regarding seating will be addressed throughout the research as the proposition continues. Things such as durability, accessibility, and the differentiation of places for rest but not sleep will all be issues for exploration during the remainder of this thesis. Ways to potentially incorporate

other cataloged elements into these seating elements will also become a worthwhile investigation.

Figure: 4-10 – A few examples of platform seating.
From Left: two from Washington, D.C.; A European Example.
Accessed 11.20.08. Various Sources (Google Images, Flickr.com).

Signage

Whether it's station location information, advertising, or train schedule information, signage will play an important role towards the details of a light-rail platform.

Integration of this element will be a key feature in creating an identity for each station, as well as partially complementing the image for the entire Purple Line.

Poorly integrated signage is easily noticed and is usually architecturally detrimental.

Figure: 4-11 – A few examples of station signage.
From Left: Dallas, TX; construcTWO, LLC proposition for a light rail stop for Detroit, MI ;
Washington, D.C. Metrobus typical stop signage; Washington D.C. Metro Incoming Train Schedule
Digital Signage. Accessed 11.20.08. Various Sources (Google Images, Flickr.com, constructwo.com).

Newspaper or Pamphlet Holders

People like to read the newspaper while traveling on public transportation or in general to receive information on a day to day basis while traveling. Incorporating elements into the design of stations for pamphlets, papers, and other handouts could be a great way to explore another smaller scale of detail.

Figure: 4-12 – Two examples of current trends for ways to give out pamphlets.
From Top: New York City Newspaper Holder; Clarendon station Newspaper bank in Washington, D.C. Accessed 11.20.08. Various Sources (Google Images, Flickr.com, constructwo.com).

Figure: 4-13 – Entire Catalog Presentation of Platform Elements.

Chapter 5: Initial Methods of Detail Design and Development

Taking Necessity for Implementation Towards a Design

Listing of Detail Elements that will be Explored

A comprehensive list of possible elements for design will constantly be updated as this proposition moves along, however currently a small list has developed. The shelter will be the primary detail for this immediate exploration. This is not the best place to start as a shelter for a platform is actually comprised of a number of smaller scale details but that will be where this investigation begins.

Elements of seating and signage will be incorporated into this first basic shelter design. Ways to create interactivity in details will also be explored. Covering will be the primary concern with the original design, but ways to create modular elements for the remaining smaller scale functions required of such a platform will be pursued.

List of Basic Methods for Design Exploration

Digital abstraction will be coupled with hand drawn design for the first iterations of these details. As slight progression increases physical models will be produced both by designing in a hands-on setting and with digitally enhanced technology (for example 3D-Printing). By a combination of these methods, basic details will be created. More refined digital crafting will arise when parametric conditional variables are assigned to arising computational designs. Versions will be tested using

both physical and digital means and a variety of materials will be used when testing in the physical realm.

Design Detail Element 1: Generic Station Platform Canopy

Basic Design Considerations and Parameters

When first thinking about the restraints and conditional modifiers present at a station platform, a few major issues arise. The primary function of these shelters is to protect a passenger from weather and precipitation. Sun protection is also desirable during bright and hot days, so elements that would act as shading devices would be preferred as well. Anything that could also protect from rough weather such as vertical surfaces or other barriers would be helpful during some of the most extreme windy, rainy, or snowy conditions but accounting for all types of precipitation and infiltration will not be necessary.

The next step in designing platform shelters would be to determine the type of platform organization. If train cars would approach on either side of a central platform, a shelter would be organized differently than if the platforms ran on the outside of train cars that run between them. Likewise, if a stop is a one way condition, depending if a train car would be located at or above grade, differing platform elements need to be explored.

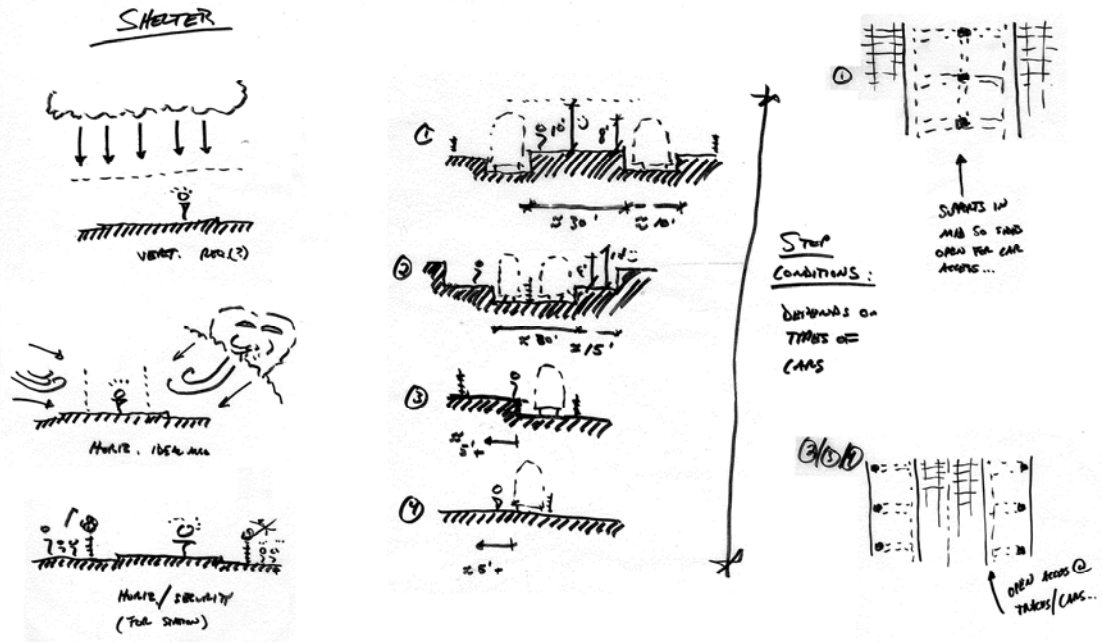

Figure: 5-1 – Process diagrams showing primary reasons for shelter & track / platform configurations.

Preliminary Detail Sketching / Brainstorming

After returning to ideas brought forth in analyzing existing inspirational details, some basic force diagrams were constructed to exhibit and explain current trends in track and platform configurations. If there is a central platform with tracks to either side, there are usually central supports with structure branching out, usually equally, towards the train access. This keeps the track side loading areas clear to allow for easier accessibility, and allows for things like seating elements to be located centrally gaining maximum protection from the vertical weather.

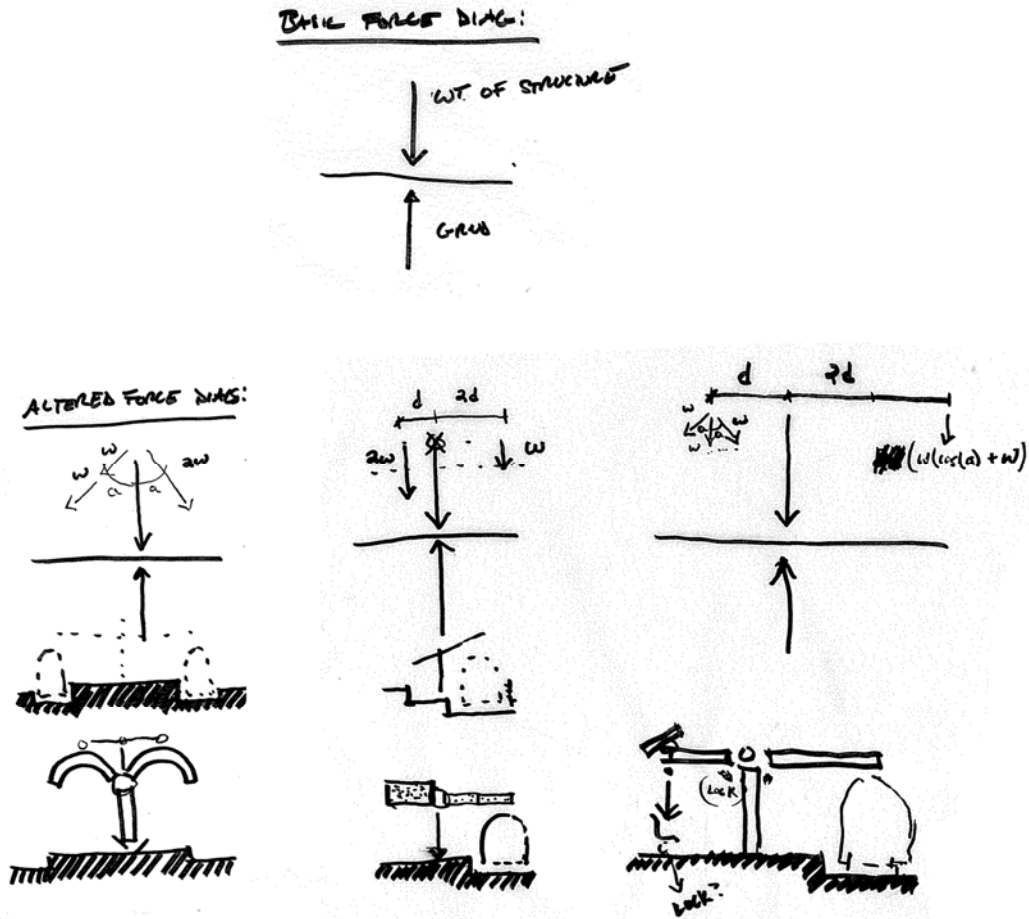

Figure: 5-2 – Process force diagram analysis of existing shelter designs.

Other force diagrams apply to single platform structures. Supports for these structures still remain as far away from the track access as possible, and usually a roof structure extends outwards from the supports towards the tracks. Sometimes these structures will be offset by larger members to one side, but still will retain structural equilibrium. The analysis of these forces will allow for more understanding on how these canopies and shelters function, but for now an approach of a side entry platform will be considered. In particular, the diagram showing a longer member, offset and balanced by a shorter, heavier member will be employed at this first run at designing a detail-filled station shelter.

The next step was to figure out how a longer member was to attach to a supporting structure and then in turn connect to a shorter member on the opposite side of that support. This would be derived during these hand drawn process sketch stages of the design. Here was designed a type of pin joint that could connect two members, in this case Laminated Veneer Lumber members (LVL), together so as to act as a continuous member. As well, this continuous member would be connected back to a support column below, also LVL's, by way of steel plates rotating about a large central pin. These plates could also function to provide a connecting point for some other system for connection to a roofing structure. There would be multiple plates sandwiched by the LVL members that would be bolted together to form these connections. The base detail, which here would likely connect to some kind of stone or masonry base would also be made up of steel plates sandwiched between the members making up the vertical column.

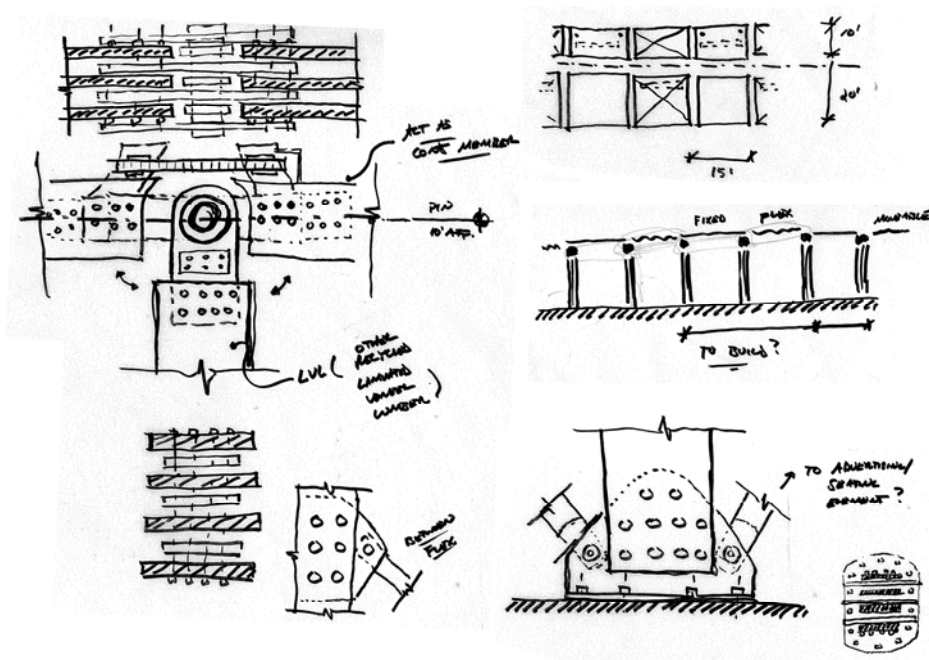

Figure: 5-3a – Process sketches for canopy pivot joint, plan layouts, and column base details.

These pivoting elements could then be grouped together and roofing could span between them. They could make up a modular pattern and be implemented in groups of two connected by rigid roofing between them, and between two group of rigidly connected pairs, a more flexible roofing could connect to them as well. This could provide for a flexible system of canopies which could potentially be moveable and dynamic. This fluttering fabric could be colored and alert oncoming transportation drivers of awaiting passengers, or could be incorporated into methods of advertising. Moving architecture is always questioned however for functionality versus cost and actual effectiveness. This would not be required but could be a unique systematic element and provide for a very exciting type of recognizable infrastructure. As far as the main rigid roofing material, glass, or other translucent material could be used. Even photovoltaic arrays may be implemented into this system to power auxiliary lighting, or ticketing machines. This roofing system could be attached via spider clips (if glass) or with any other attachment method that could be integrated into the aforementioned plates that were sandwiched between the continuous LVL beams.

Lastly, some element would be needed to assist with the off center, balancing canopy extensions. Here seating could be attached to the other end, opposite the track access to provide for a catch, and an ideal place to sit. This seating could weigh enough to balance out the rest of the canopy and then be further attached to a base element to shift up and down when people choose to sit. There would be need to be some stop or catch of course to prevent people from getting catapulted out of their seats, but a slowed system could adjust the height of the seats, and the angle of the platform

shelter. Again, when used in combination with the dynamic fabric implements, this station stop element could be a very exciting and enjoyable place to be.

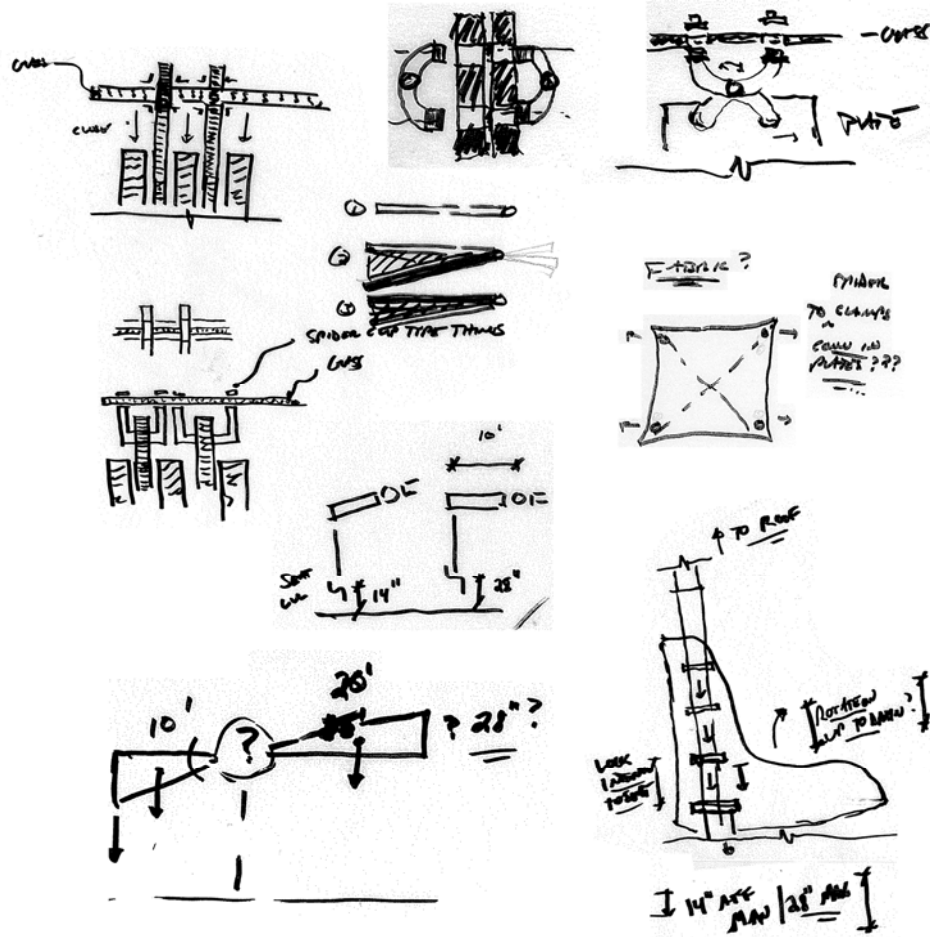

Figure: 5-3b – Process sketches for shelter roof attachment, fabric connections, and basic seating ideas.

Digital Constructions

When proceeding towards digital technology to explain this system, a few issues arose. A hint at material in general would be desired for presentation media; however a lack of understanding was still in place. After looking at some firms who combine metal and wood in successful fashions such as Bing Thom Architects, and James Cutler, the tectonic system of using these plates to connect to wood via bolts was understood as feasible. Again, lateral forces may not have been the most understood

here for the overall implications of such a structure, but general assumptions about required elements would suffice.

For these station platform stops to function they would rely on the shear support and overall stability of the base detail connecting these columns to the ground. Therefore the base detail needed to be very sturdy and heavy duty. Lots of anchor bolts were added and there was an assumed masonry or other high impact system in the base of these platforms. The actual number of LVL's necessary to support the actual gravity, and live and dead roof loads, was not calculated but four were chosen for the columns, and three were chosen for the horizontal members supporting the roof.

This, in the end provided for a bulky looking design, which led to the conclusion that perhaps less was necessary. Many bolts were also added to connect the plates to the top of the column and to each of the extending members. More were added to the longer side than the shorter extending side, but this is probably the most important connection in the whole system so over-stability is probably a good thing. As well, the pin that would support the entire system would be a solid steel pin roughly four inches in diameter.



Figure: 5-4 – Shelter 1.0 track side view.

The seating could also attach to part of a sandwiched plate at the end of the shorter extending member. This plate could then connect to a more graceful clevis and pin system to run cables or steel tension rods down to a seating element. These tension members would help to keep the seats in place, hold back the balanced member from tipping over too far towards the tracks, and be a more finished way to resolve this end of the system. The seats would again, ideally be heavy as to offset the weight of the longer extending roof structure but would need slots, or some way of being attached to the ground. Again, these seats would have to be attached in a way to allow for vertical movement as these canopies embark on their dynamism.



Figure: 5-5 – Shelter 1.0 integrated seating elements.

Elements of signage would also be integrated into this system. All of these canopies would be arranged in modular bays so parts and pieces could be interchangeable. A signage element could easily be added by making the base plate a little larger, adding additional spots for pins or other members, and implementing new plates between the sandwiched LVL members. In these examples, the signage element was constructed with an additional plate sandwiched midway up the LVL column, a pin connector attached to the base plate, interlocking members connecting those two locations, and finally steel rods connecting two instances of these members across the modular distance between canopies.

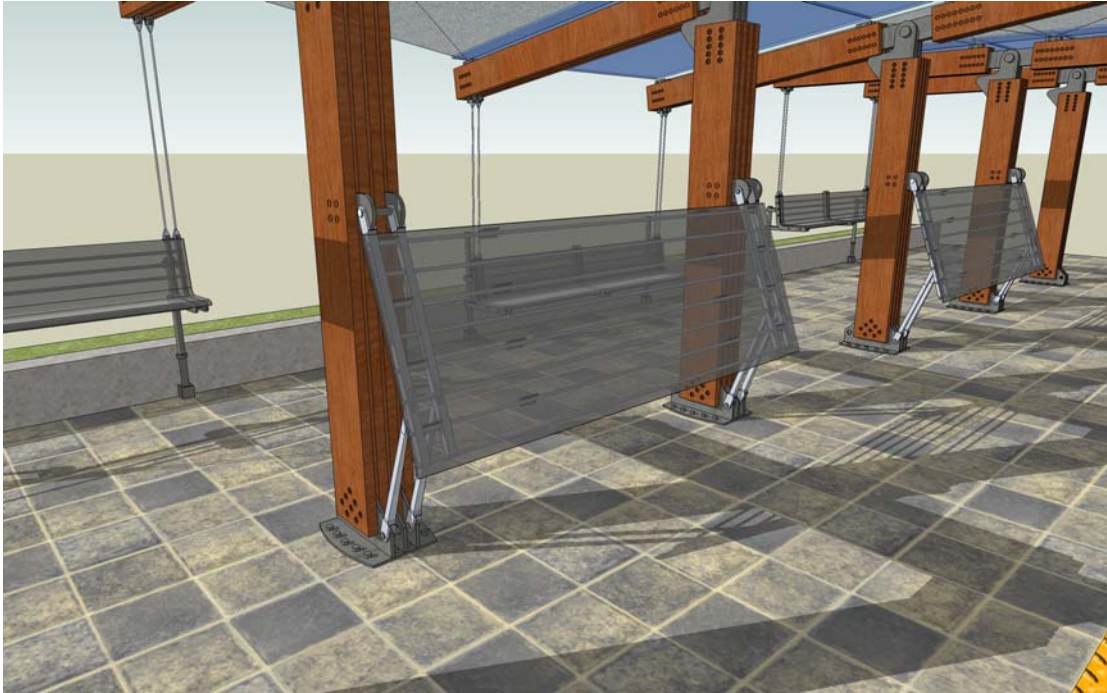

Figure: 5-6 – Shelter 1.0 modular signage component.

Lastly, between rigidly connected bays of evenly spaced supports, another roofing system would need to be used to account for differences in the operating heights of the canopies. A fabric system could be used to provide a slight amount of lateral stability between bays, but also as an element that could be flexible over time. This fabric could be colored, have signage incorporated within it, or otherwise be a signal to oncoming car drivers that the station was occupied. This fabric could be connected to the very integral plates connecting the ends of the LVL supports together, and simultaneously supporting the glass or other translucent rigid roof system.

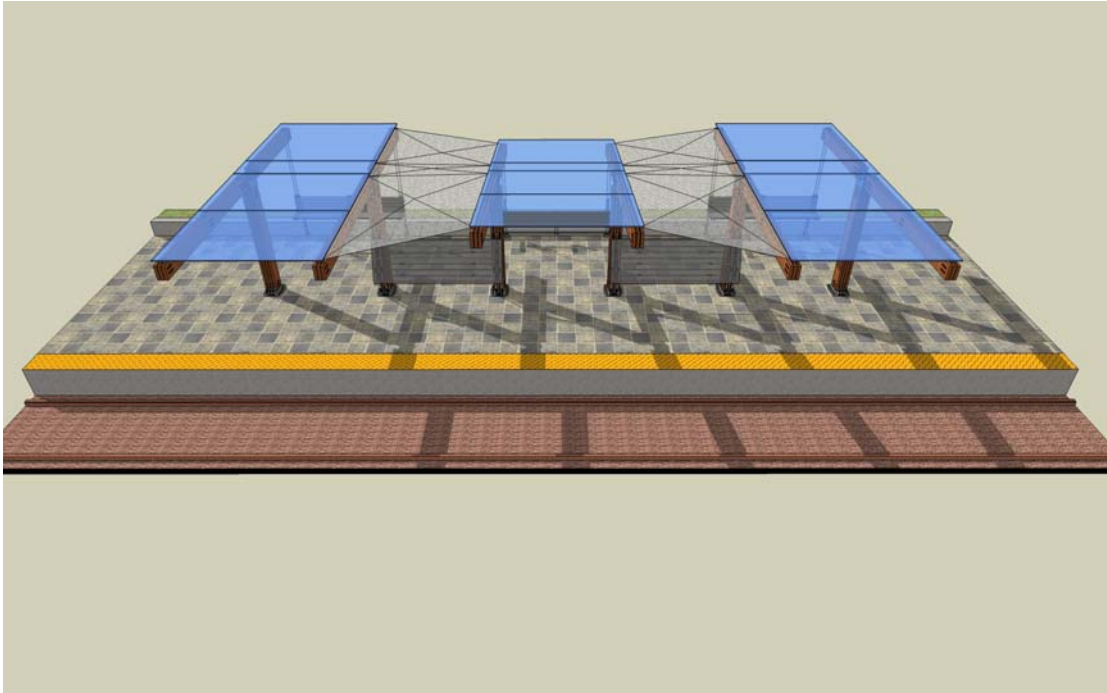

Figure: 5-7 – Shelter 1.0 dynamic fabric connecting rigid bays.

Digital Alternatives

A slightly later thought occurred in this design process concerning materiality. Questions arose regarding the lifespan of wood members in a public transportation network. Wood could be carved, written upon, and otherwise destroyed over a lifetime in the public realm. The desire to then see the design function with steel arose. The following images are the same views as above, but show how the architectural design could be implemented with steel instead of LVL's. In these following examples a purple tone for the rigid roofing material was chosen as a potential design idea to further signify the Purple Line station stops.



Figure: 5-8 – Shelter 1.1 track side view.



Figure: 5-9 – Shelter 1.1 integrated seating elements.

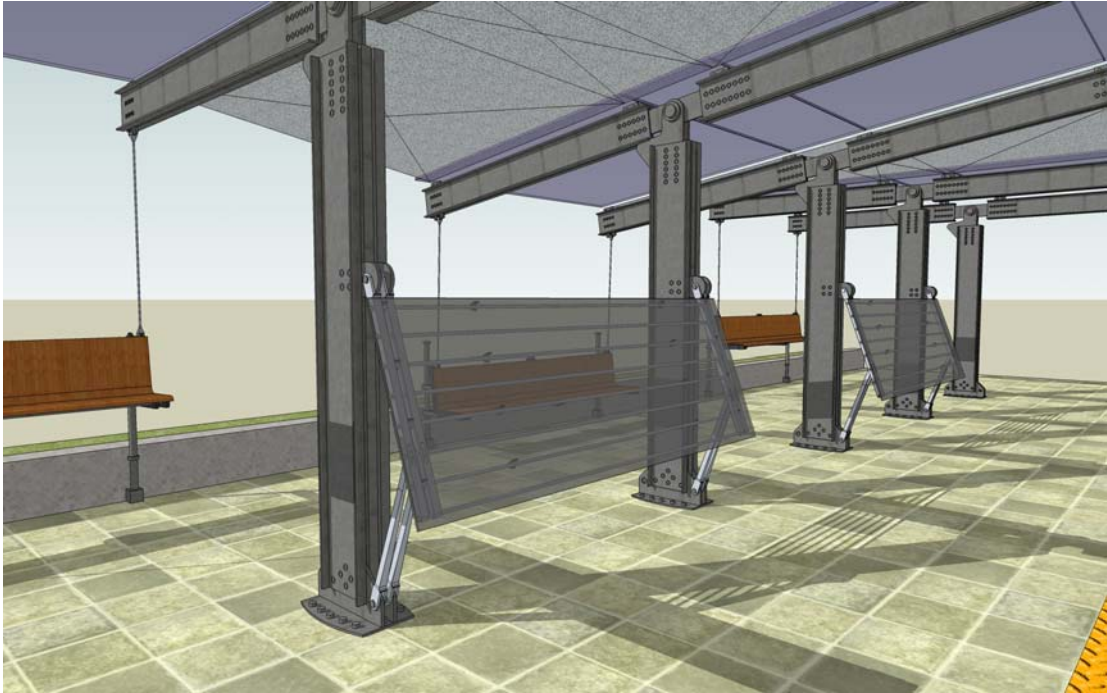

Figure: 5-10 – Shelter 1.1 modular signage component.

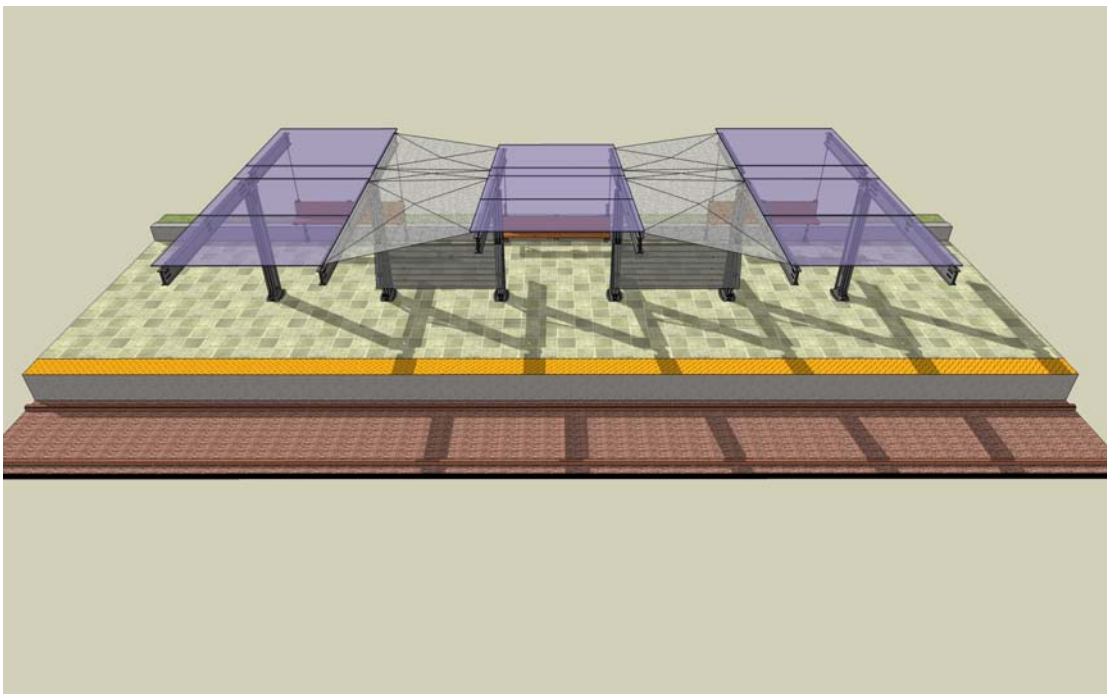

Figure: 5-11 – Shelter 1.1 dynamic fabric connecting rigid bays.

Platform Scale Alternatives

As the station platform systems move to different locations the scale of these canopies may change. A bus stop in a more urban environment will not be of the same scale as an entire transfer station in a residential neighborhood. However the language and physical type of elements could be combined with lots of variety and implemented at many different scales. The next set of design images relate the original station stop designs to scaled-down versions to be used at more urban street side locations. These would be more of a quick retreat as one would sit for a few minutes to wait for an at-grade light rail car to approach. However the materiality would be much the same as their larger, older brother, more prominent station stops. Also the functionality and adaptability of these stops would be the same as the larger. Here however, the integral fabric would not be necessary as a continuous, possibly structural element, but could be incorporated more for signage or other graphic display and/or advertising.



Figure: 5-12 – Shelter 1.0s street side view.



Figure: 5-13 – Shelter 1.1s opened up street side view.



Figure: 5-14 – Shelter 1.0s frontal view.



Figure: 5-15 – Shelter 1.1s detail of signage module alteration.

Design Issues and Conclusions

After this shelter design process was complete a few questions and concerns arose. There first will be a need to step back from a design that came to fruition too fast in this process. This is basically an accumulation of a few too many details that are only about one-third designed. In applying textures to a digital model, issues concerning how these supports actually meet the ground were ignored. The detail focus in this experiment was primarily regarding ‘joints.’ Not that this is not an acceptable ‘detail’ to pursue, but there are many other ‘details’ in this system. The material change to steel being simply applied to a system designed for wood would probably not coincide so closely. The nature of wood and how it connects to things is drastically different than that of steel. The members extending should diminish their thickness as they move away from the balance point due to the actual diminishing forces being

exerted on the material. There is no need for them to maintain a thickness all the way to the track side of the platform. This issue made these stops appear much more bulky than originally intended. Also having moving joints in a public system could pose to be more of an annoyance than a blessing. The detail of how the seating elements work here would be very critical to figure out more in depth. There would need to be some sort of dampening system to ease the transition up and down and again, there would need to be stops to prevent the weight of the longer member from catapulting the occupants out of their seats. With all of these problematic issues however, a few beneficial observations did seem to arise.

The idea of combining different materials using joints and details seems very feasible. Many architects have done this with lots of success and this will continue to be an issue explored throughout this proposition. The ability to keep language, style, and general architectural elements between stations seems very helpful as well. The potential for differing scales and systems based off of one major set of design guidelines could allow for a great number of variations while still maintaining an overall image for the Purple Line. Lastly, ideas concerning modularity, mass production, prefabrication, and implementation of interchangeable parts can only be beneficial. Also, this system could easily be set up in one night if there were pre-placed anchor bolts for all of the ground attachment. Fast assembly would be of the utmost importance in implementation of these station stop elements. There would be more of an issue with this regard in high traffic urban areas of course versus residential areas, but still, any integration that could be done in faster phases would

only save money in the long run. It would be interesting to see an entire purple line system appear over night. With the right digitally aided designed parts and prefabrication technology, this might be a realistic goal.

Chapter 6: Refined Methods of Detail Design and Development

A Step Back to Analysis

A Reexamination of Station Stop Configurations and Train Cars

After simply diving into a design problem, that of the need for a generic shelter for a station stop, a few key points of analysis were missing. Another look at the station stop configurations was necessary. Additionally, a return to an analysis of a specific type of light-rail train car would help in setting up some final constraints for a more informed design.

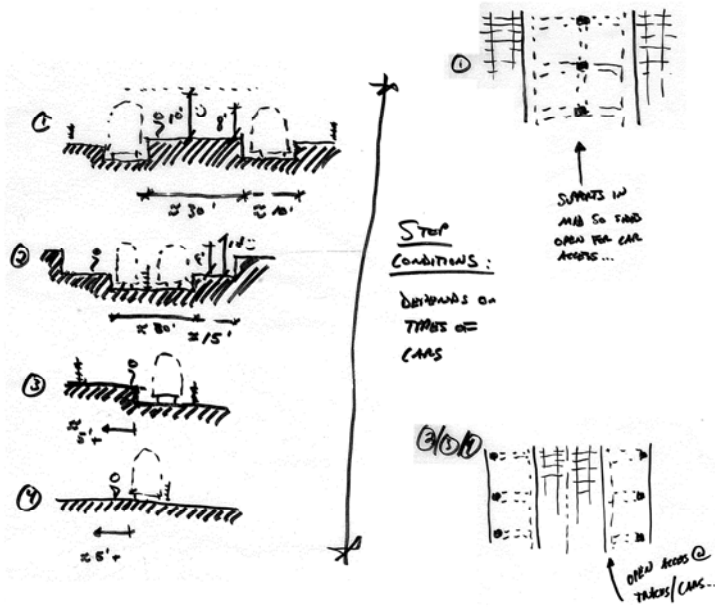

Figure: 6-1 – Process diagrams showing primary shelter & track / platform configurations.

This diagram is brought forth again because it will describe the two major configurations for station stops that this proposition will be dealing with. In the above example, a double sided station stop will be explored where the tracks and light

rail train cars would run along the outside of the stops, while the case at the bottom, the stops would be on either side of a street with the train cars running between them. When these basic configuration diagrams are paired with a specific light rail car, that of the Siemens S70 low-floor train, some very specific bounding regions can be established.

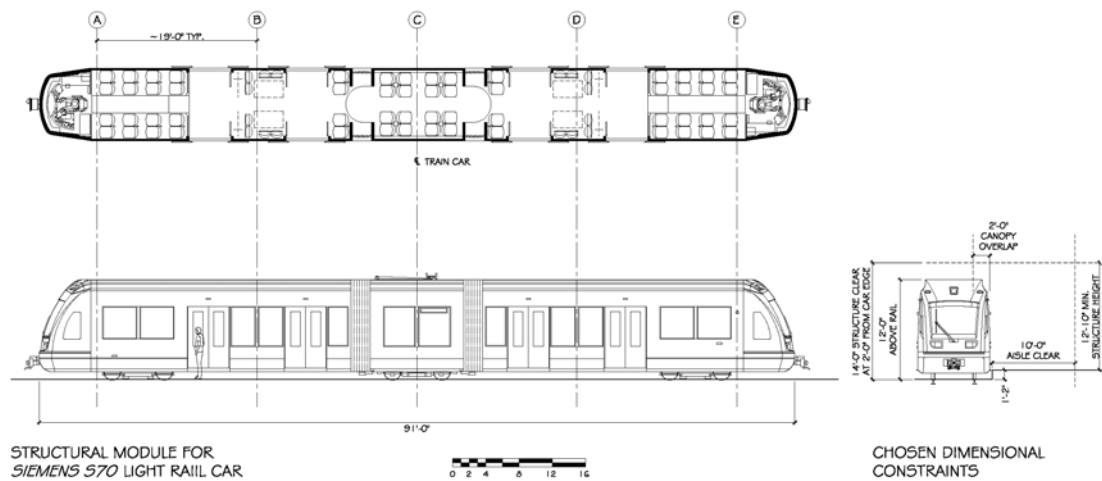

Figure: 6-2 – Siemens S70 Constraints and proposed 4 bay structural station stop layout

As this analysis drawing of this more modern light rail train car shows, a few minimum clearances for a structure should be observed. First, there should be at least 2'-0" clearance above the actual body of the car to allow for pantograph operating height (that being the device that would make contact with the overhead powering wires). As well, for ease of circulation on and off of these trains, structure should be set back roughly 10'-0" from the edge of the curb. Lastly, a choice was made to cover part of the train by the canopy to ease entry during rougher weather conditions, so a constraint was made to cover the car by at least 2'-0". These three conditions set the lower bounds for the shape of a canopy structure and would become the sectional guidelines in later designs.

In elevation, as one would traverse along a station platform, a 19'-0" structural module was established. Based on the length of the train, and the position of the entry doors, this module would allow for the easiest passage into and out of the trains. Also at 19'-0", this bay size would allow a driver of the trains, to easily align the train when stopping by just passing the last element of structure when looking out of the driver side window. This bay spacing would still allow for some error with that type of driver-assisted stopping, while keeping the entries to the trains relatively open. A uniform bay spacing was chosen to ease fabrication of these future structures. If more repetitive items could be produced, these station stops potentially could be financially cheaper and again this ideally would create uniformity to the entire system. If two or more linked cars would be used, the 19'-0" module could simply repeat based on the bounds of the individual stop locations.

A Look at the Structural Forces at Play

Based on conditions set up in the previous sections, some basic ideas about a supporting structure were established. In either stop configuration, structure would be set back from the curbs along the train car right-of-way. To keep the most room available under the canopies free of structure as one approached the train car, it would make sense to cantilever a roof structure towards the tracks. In doing this however, a few structural issues would arise.

To keep a roof structure supported in a cantilevering situation, a strong connection would be required between a columnar element and elements that would extend out to

towards the tracks. This connection would have to prevent the rotational tendency of the cantilevering roof from tipping over. Along the base of the columns, another connection would have to prevent the entire structure from toppling over due to the weight alone of the cantilevering roof. Lastly, in a system of multiple bays of structure, a connection would have to be made to deal with basic issues of lateral stability to prevent the entire stop from collapsing side-to-side.

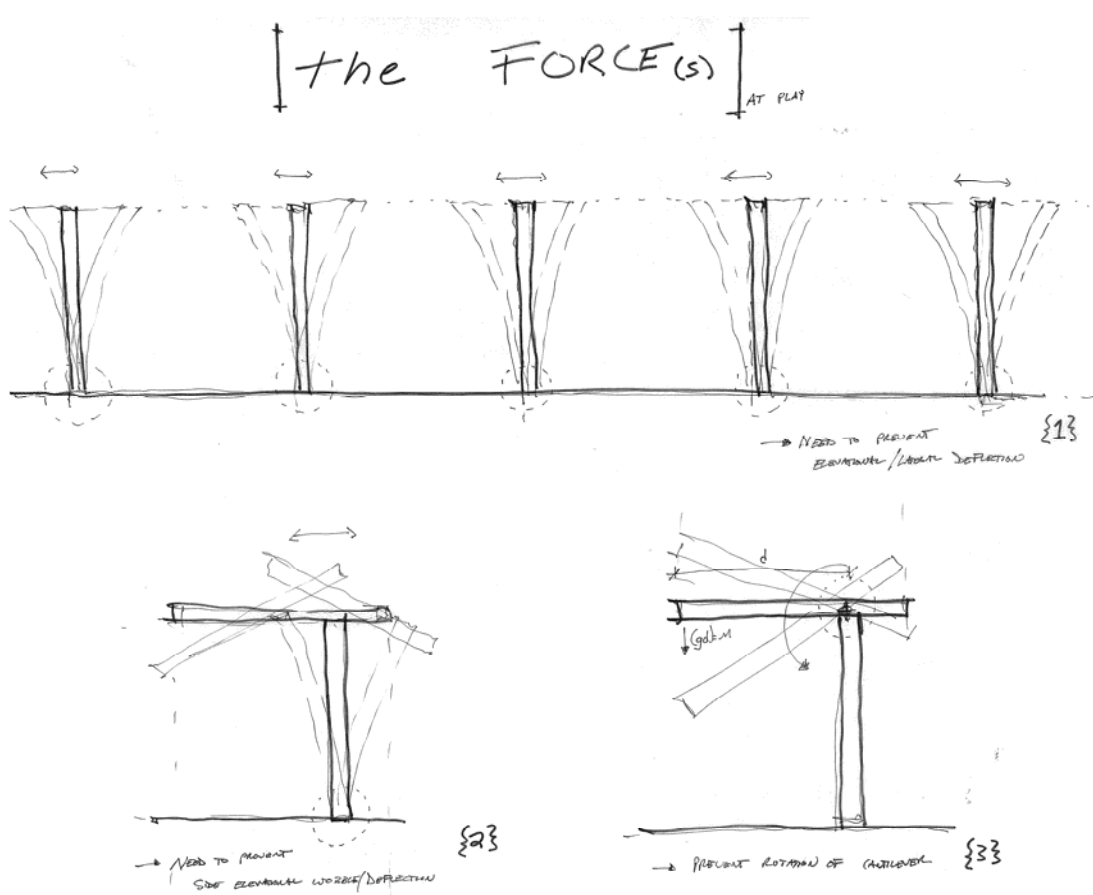

Figure: 6-3 –Basic Structural Forces in a Cantilevering Roof Structure.

Another structural issue that would also be considered had to deal with issues of uplift, depending on how massive, or not massive, the roof structure might become. Finally general structural properties would shape certain structural elements. For example, the ability of roof-supporting members to diminish in thickness near the

extents of the roof. This can happen because these members are holding up less weight near the edges of the roof, while at the middle, near the columns, the most weight is supported, and hence the increased thickness of the members. These general issues would need to be solved for basic erection of these structures, but the diagramming of these conditions would become the basis for beginnings in the actual station stop designs.

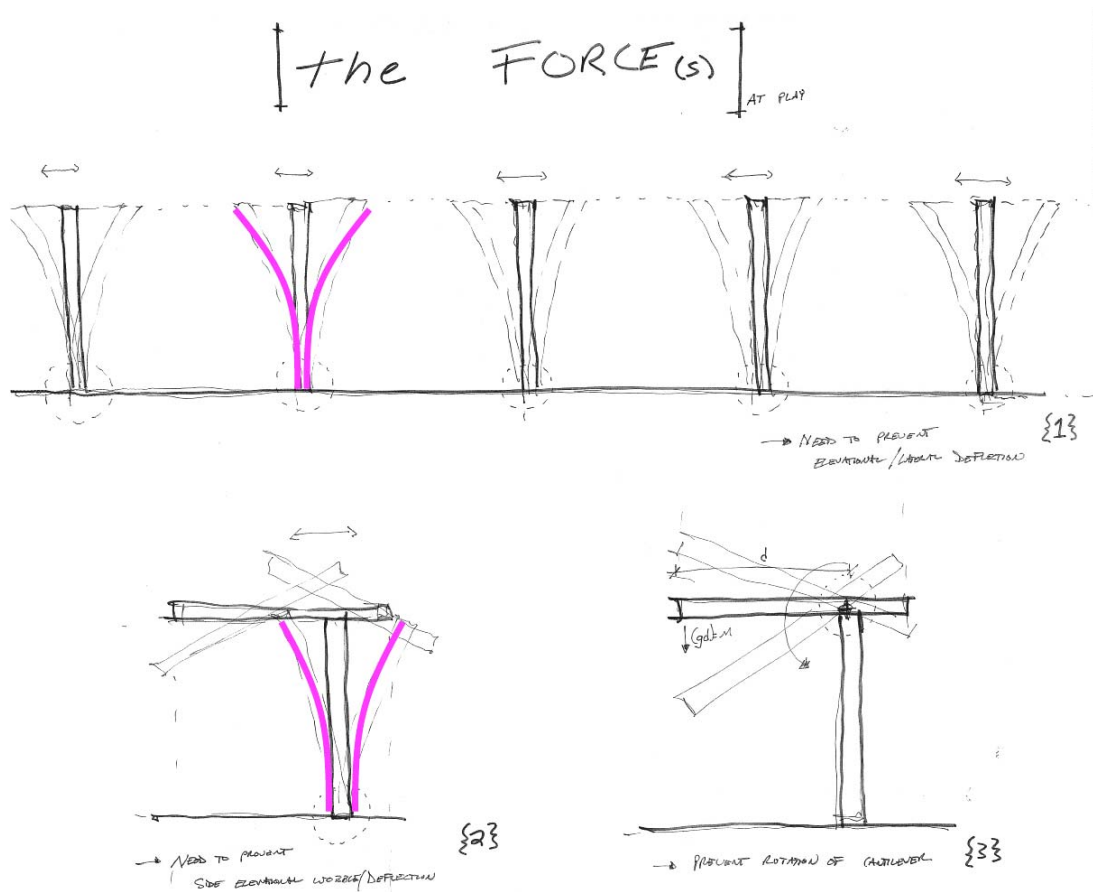

Figure: 6-4 –Major Force Lines to become Generators.

Diagrammatic Responses to Structural Forces

After this initial diagramming of structural forces to combat, two differing approaches toward resolution were attempted. These two solutions would take on different material qualities and begin to embody two different methods for structural

resolution. A station stop based in additive and framed wooden members would begin a discussion about tectonic and constructional efficiency and embody a Cutler-like style of connection and detail. On the other hand a steel-based solution would begin to describe a structural efficiency and provide for a sleeker and more Calatrava-like set of designed details.

The wood-based stop configuration would take the primary stance that a more rigid condition at the base would be preferable to support a roof structure above. However, combined in an almost crane-like fashion, tensile members would hold projecting roof members up and return the resultant structural forces to the rear of the canopy. The structure would in essence be tied back to the ground, thus reducing strain on the immediate connection between roof rafter and beam-column assembly. As well, there would be tensile members that would effectively cross-brace the entire structure to improve lateral stability.

[the FORCE(S)]

CONTINUED ON SCHEMATIC 1.

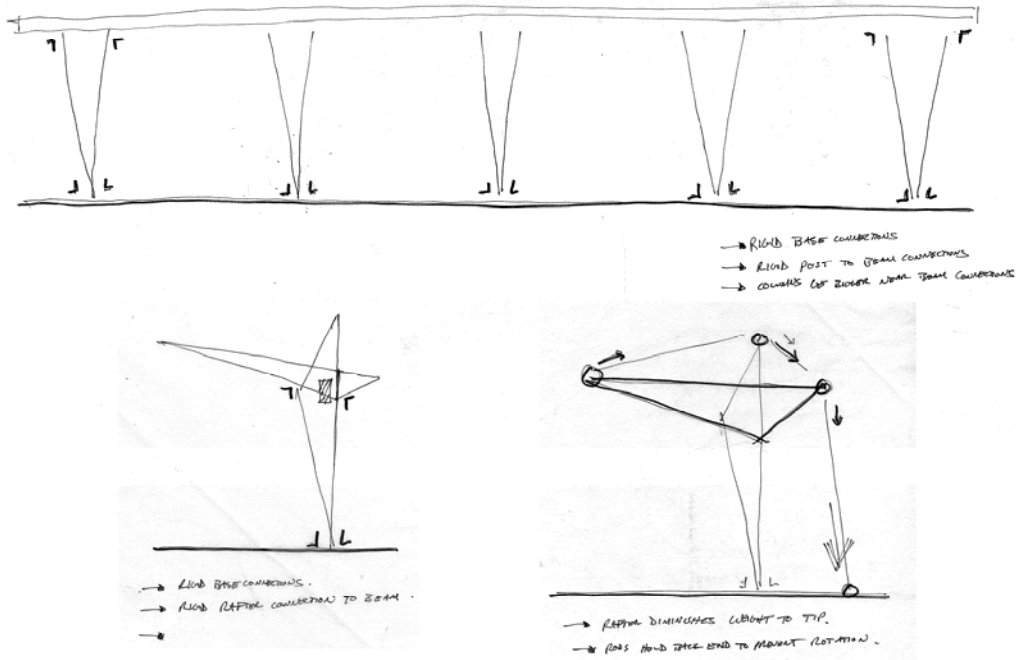

Figure: 6-5 –Force Resolution 1: Wood Based Stop Ideas.

The steel-based configuration would develop a new approach to the typical column assembly. Instead of a single generic post, as the wood stop could be simplified to embody, an assembly of members that would form a tripod would be developed. This tripod could become a great device to mediate the structural towards lateral forces and could create an interesting architectural zone to incorporate other station stop elements. Additionally the idea of this tripod would prevent overturn from front to back, assuming the roof was made of more light-weight materials. However, to make the rest of the structure work, moment connections would have to be developed to keep a roof member supported that would extend out towards the tracks. This

member would rigidly connect to a beam structure (proposed here as perhaps tube steel) that would in itself prevent against the rotational forces exhibited by the roof structure. Lastly, that beam structure would have to rigidly connect to the column structure (tripod) to prevent itself from rotating. Finally, this solution could take the shape of diminishing members to support the roof, as well as when the tripod assembly met the ground. Again, these gestural shapes embody the structural forces occurring within these systems.

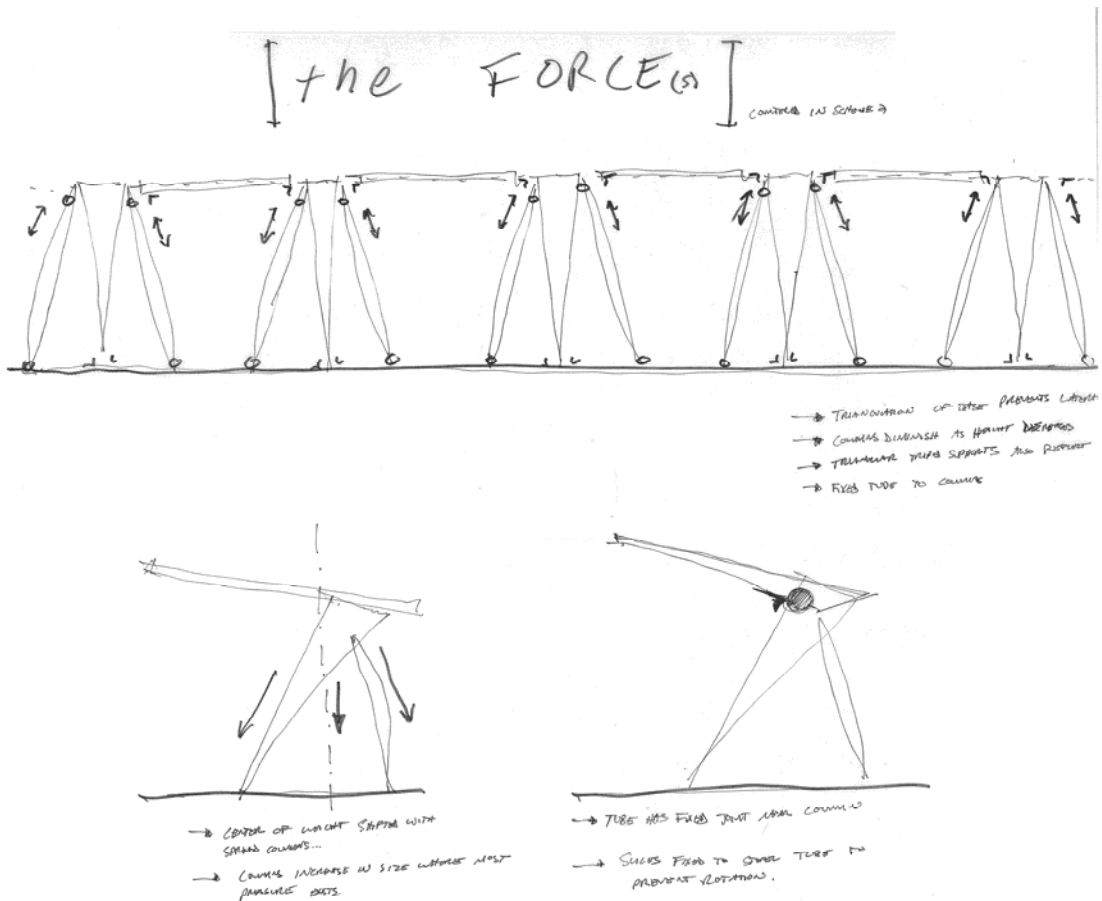

Figure: 6-6 –Force Resolution 2: Steel Based Stop Ideas.

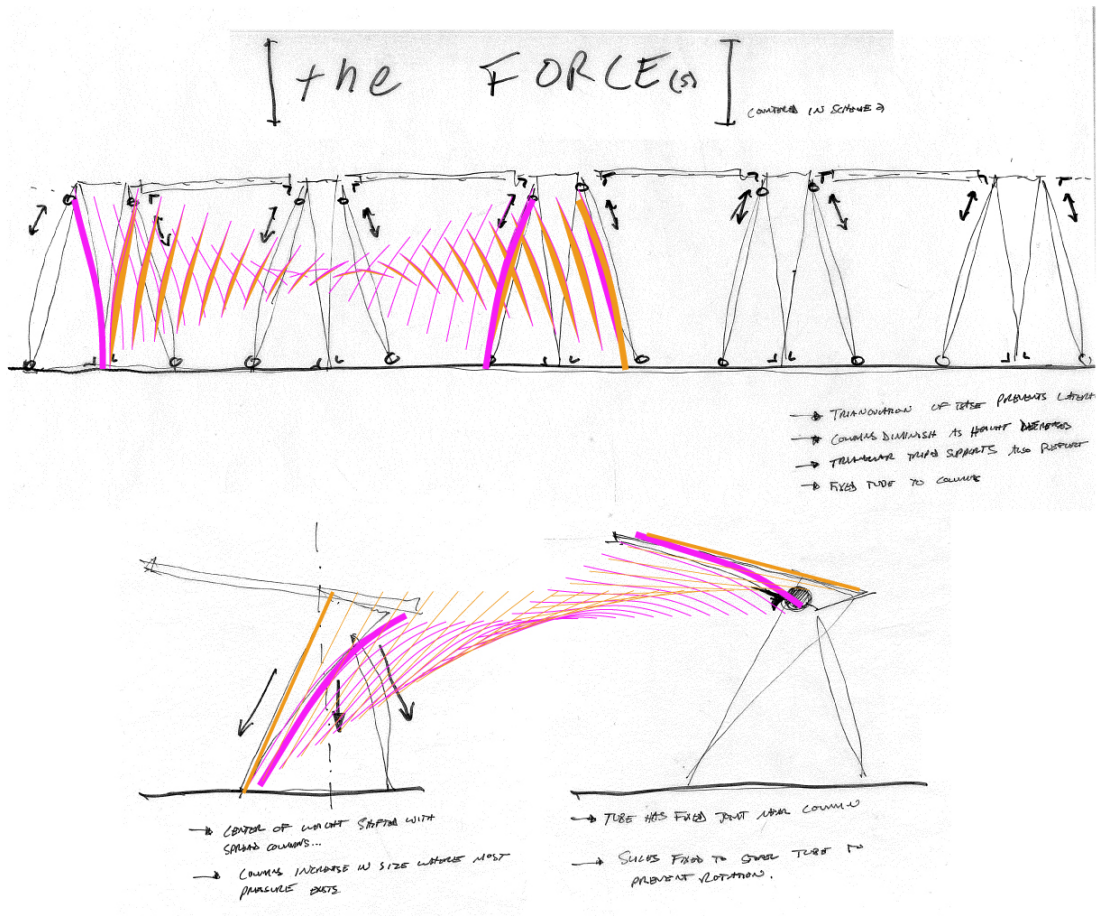

Figure: 6-7 –Force Resolution 2.5: Major Force Lines to become Generators.

Wood Based Station Stop Progression

Gestural Thoughts

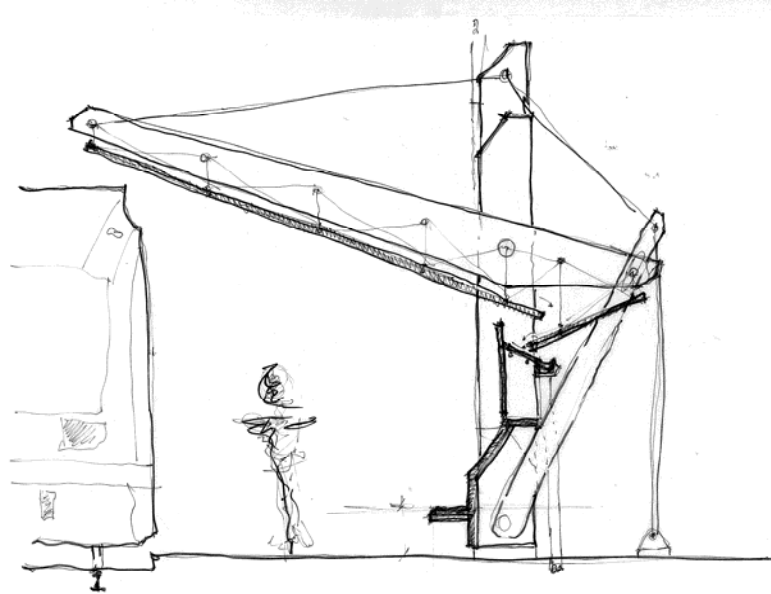

Figure: 6-8 – Gestural Wood Based Crane Stop.

In a similar fashion that was used prior to this step, a sectional approach was used to generate a basic form for a wooden-member station stop. Again taking cues from the constraints established earlier in this section and taking notes from the wooden solution to the basic structural forces, this rough idea was generated. A stacking and interlocking vocabulary of pieces would be used to stick frame a columnar structure for this station stop. Ideas concerning tiebacks using tensioned members would also be considered. Here a rigid base approach was roughed out to create a larger connection to the ground, but additionally the tie backed connection would also have to be very foundationally secure.

This gestural drawing also raised issues about roof materiality and types of connections between that material and its supporting structure. Additionally thoughts

concerning placement of seating, possibly within the columnar structure itself were considered.

Diagrammatic Progression

Later a model was made to show in three-dimension this system of interlocking parts and tensioned tiebacks. This model then reminded the author that issues of lateral stability would still need to be considered and a roof structure and interconnecting system would need to be developed.

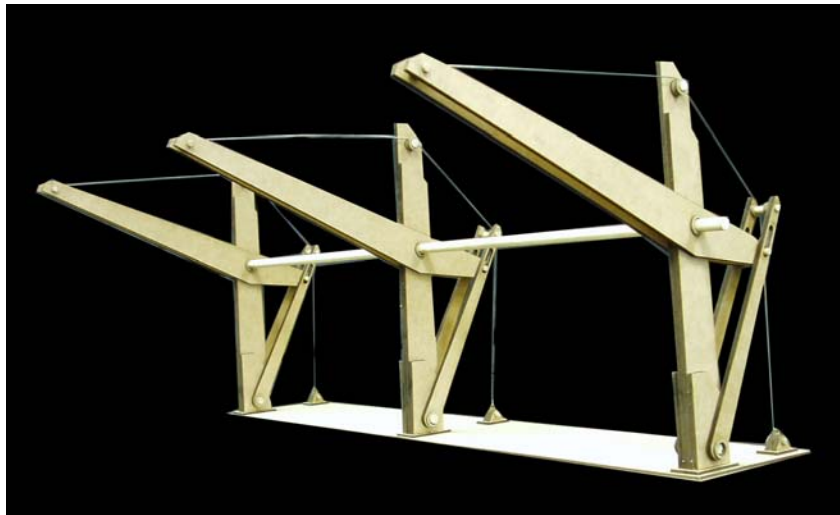

Figure: 6-9 – Diagrammatic Model – Wood Based Stop.

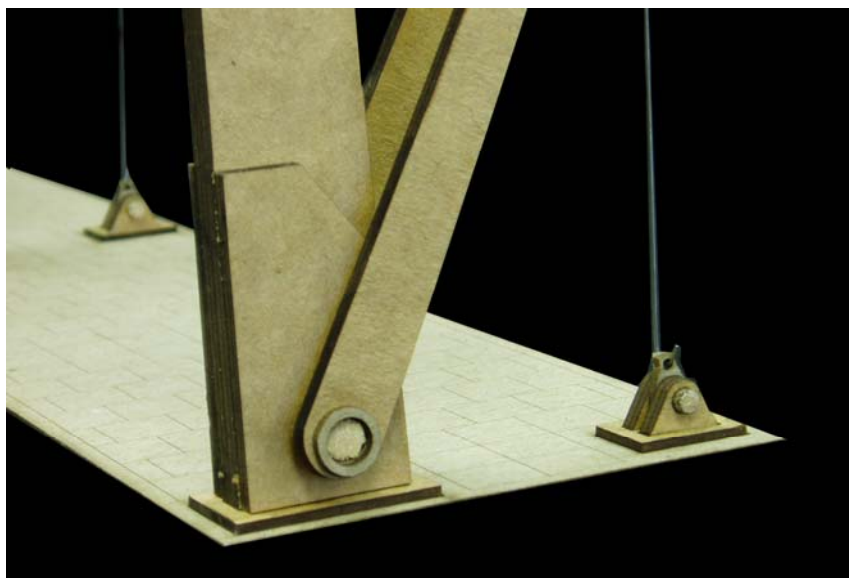

Figure: 6-10 – Diagrammatic Model – Wood Based Stop Detail.

After roof concerns arose, certain related details were modeled out of actual sized wood members, in this case 2x4's. The basis for these designs would be to see how a system of purlins could be attached to generic rafters (as the diagrammatic models contained large rafters, but no other spanning elements). After later criticisms, it seemed that the most simplistic version of these connections would be preferred as there would want to be minimal cutting of these members and that a simple stacking of post-and-beam approach would normally be used. This material exploration was a good way to test actual material performance in this type of situation, but lack of actual roofing material allowed for probably a bit too much of freedom when designing these four situational details.

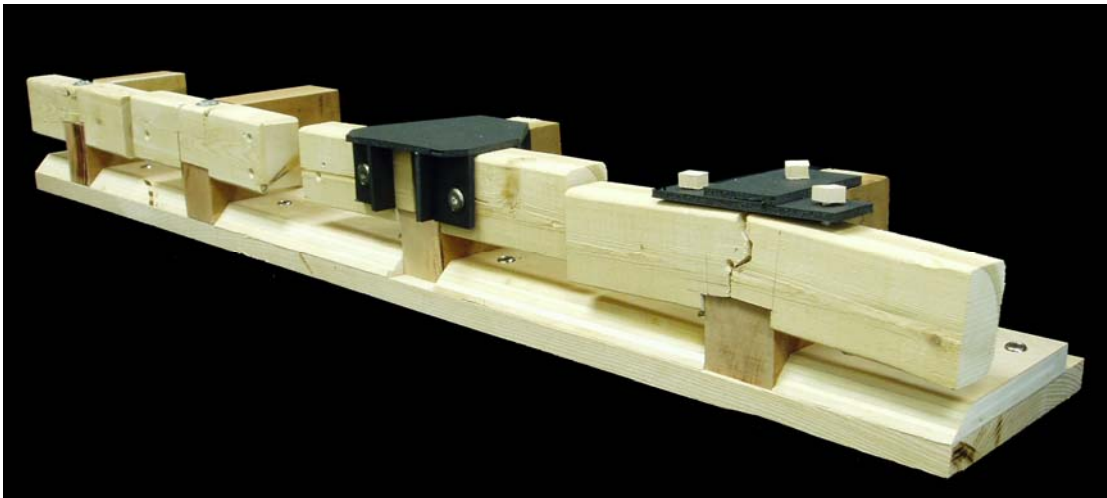

Figure: 6-11 – Diagrammatic Model – Four Purlin-to-rafter Connections in Stand.

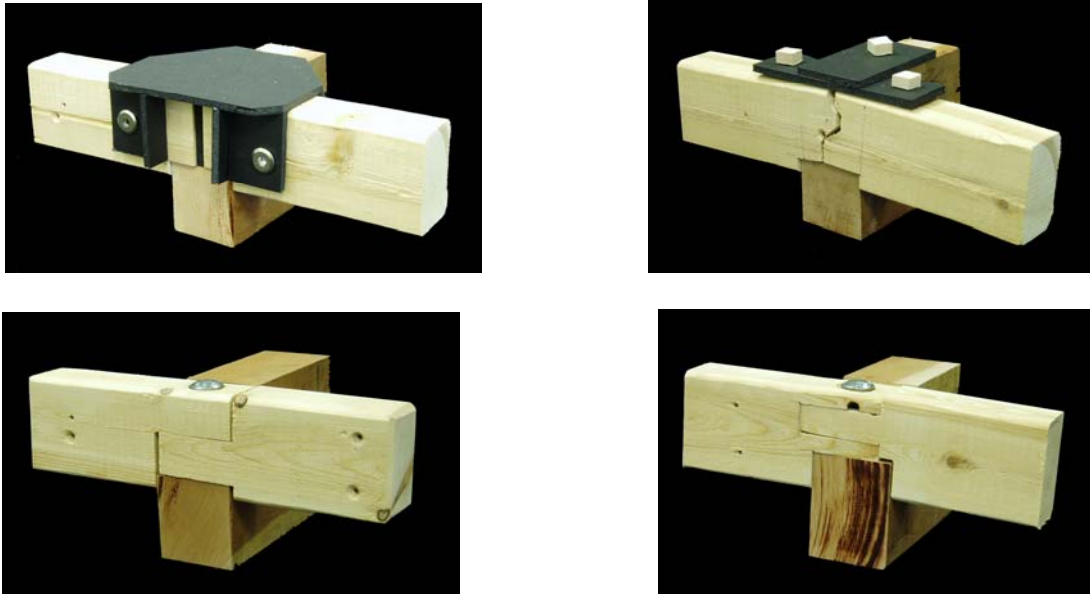

Figure: 6-12 – Diagrammatic Models – Four Purlin-to-rafter Connections.

Conception or More Accurate Representation

Finally these ideas and details would combine into a more developed four bay station stop design. Issues of lateral stability would be solved by adding more places for introduction of tensile members, and the roof structure would be solved by adding additional rafters and by introducing these purlin connection elements. The actual roof material could be a light-weight polycarbonate material which could be assembled with light-weight frames which could then be easily bolted, clipped, or otherwise fastened to the purlins.

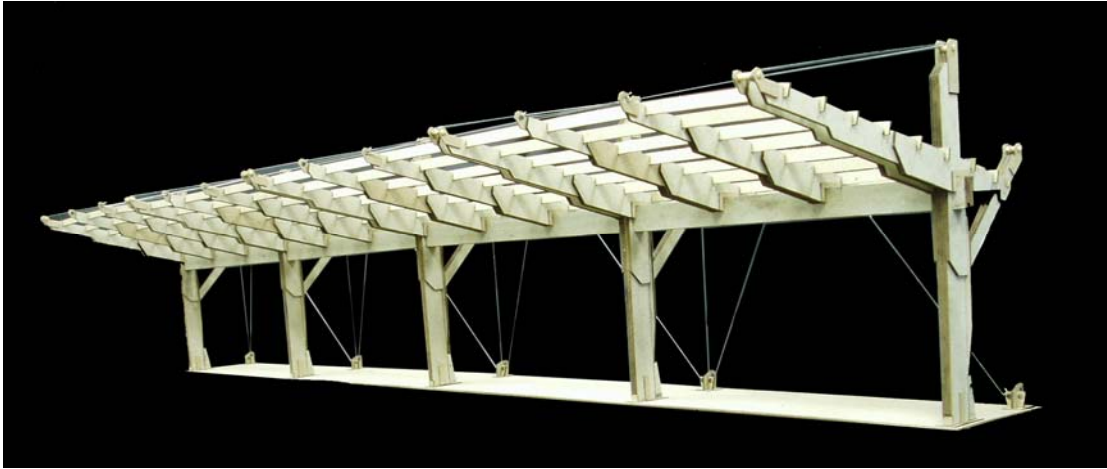

Figure: 6-13 – Conception Model – Four Bay Wood Station Stop.

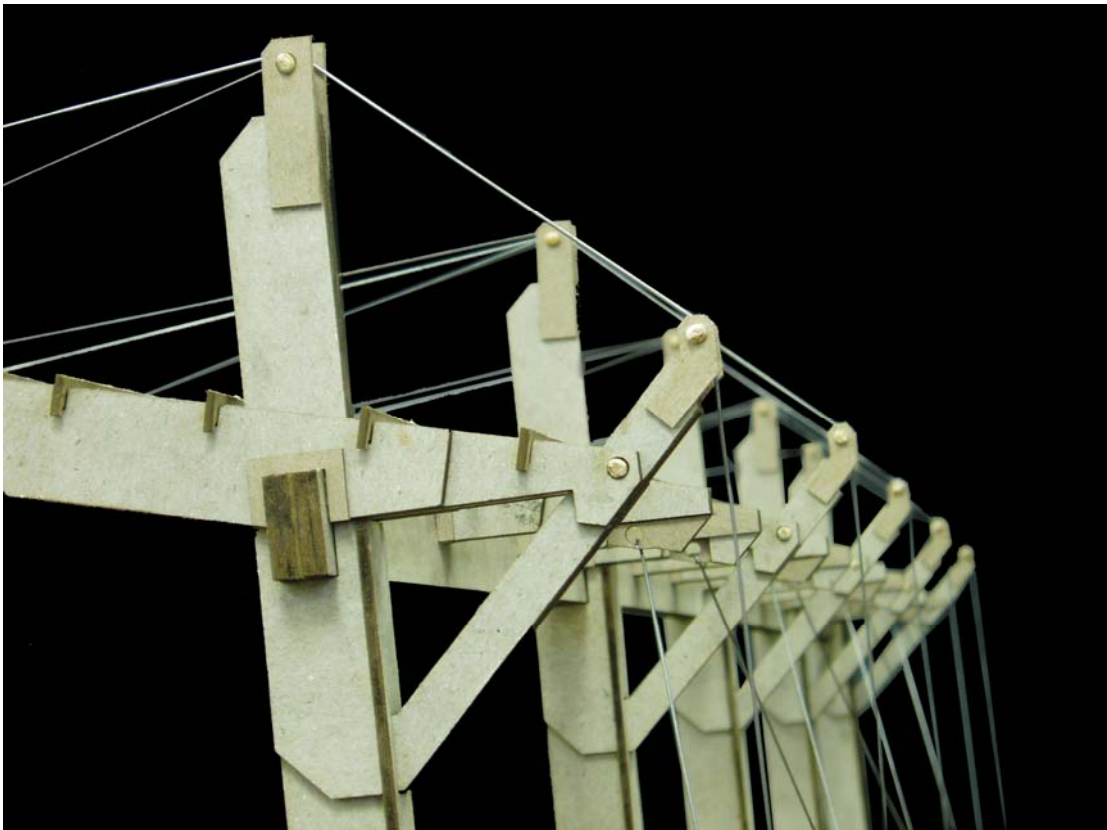

Figure: 6-14 – Conception Model – Four Bay Wood Station Stop Detail.

Other structural issues were basically resolved with this intervention by pure massiveness in member size, and overkill in structural systems. Rafter thickness diminished towards the track side, however due to the attempt of resolving lateral forces by the addition of more tensile members, the rafters were proportioned

incorrectly due to how this particular system would structurally work. The members would not diminish in this case because they are supported from both ends, and instead would naturally want to be more massive in the middle of the rafter. If the rafter members did not have the wire support at the end, then they would diminish as the earlier diagrams suggested. The base connection used here was also over complicated for this system. The addition of more pieces that might have been bolted together would not have been necessary with all of the lateral bracing. In the case of a rigid connection like they are describing here, less tensioned members would have been needed. Lastly, overall this structure may have appeared more interesting due to an overkill of structural systems. In the end, this structure appeared very heavy, again potentially due to the abundance of supportive elements, not to mention the incorrectness in combining unlike systems. However, the system of applying a light-weight roof structure to a rafter and purlin system will become important in future versions of this canopy intervention.

Steel Based Station Stop Progression

Gestural Thoughts



Figure: 6-15 – Gestural Model – Steel Roof Structure Diagram.

In beginning thoughts about a steel based station stop, a few important points would be explored. First columnar structures, in the above model not expressed, would support rigidly a tube of some sort. This tube would then support a system of roof ‘slices,’ basically rafters, which would then support the roof itself. This structure would need to be laterally supported, attempted above by the additional brace employed, but later solved by the idea of the tripod columnar assembly.



Figure: 6-16 – Gestural Model – Diminishing Roof Structure.

These roof slices employed would have to be rigidly connected to the tubular beam and would also have the ability to diminish in mass towards the tracks. A sleek profile could be developed to directly dialogue with structural forces, while taking on an aesthetic identity.

Diagrammatic Progression

In taking a look at the previously described necessary details, a few models were made to explore those specific conditions. The large detail model of the slice below attempted to provide a location to explore this connection. Generic column supports were placed simply to hold up a generic tubular element. However, ideas about the three dimensionality of the slice and how that slice would be connected to the tube were developed.

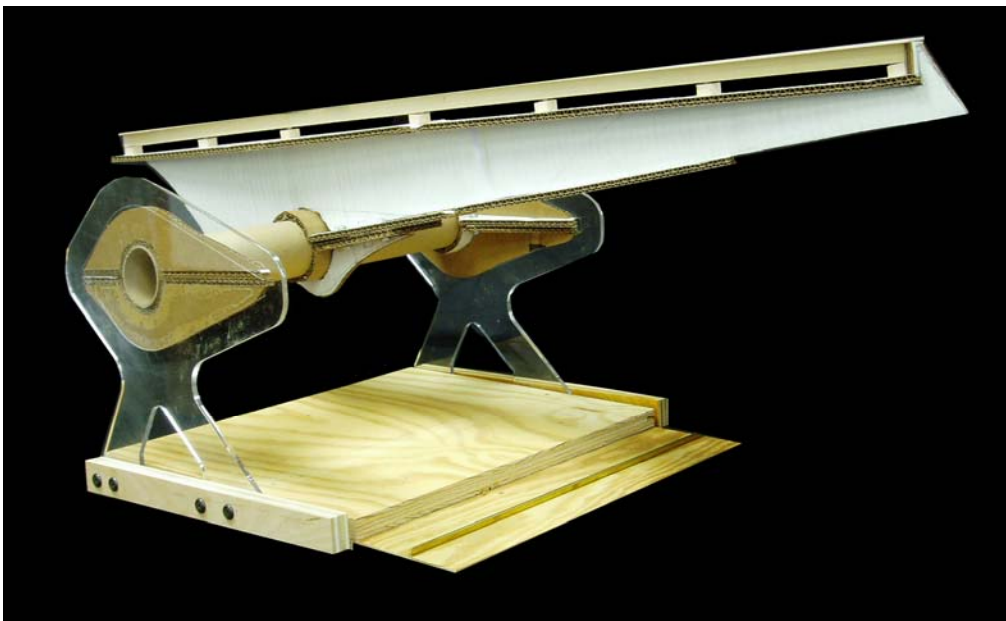

Figure: 6-17 – Diagrammatic Model – Roof Slice Attachment.

The tubular assembly would come prefabricated with lower supporting flanges that would be attached by welding. The slices would also be prefabricated with top

flanges that could be used as attachment locations for a suggested roof material of framed polycarbonate, and lower flanges which would have bolt holes for in-place field attachment. These slices would surround the tube steel and could easily be bolted in place after being nestled into position. This idea of connectivity will become a prevalent idea through later iterations of these station stops.

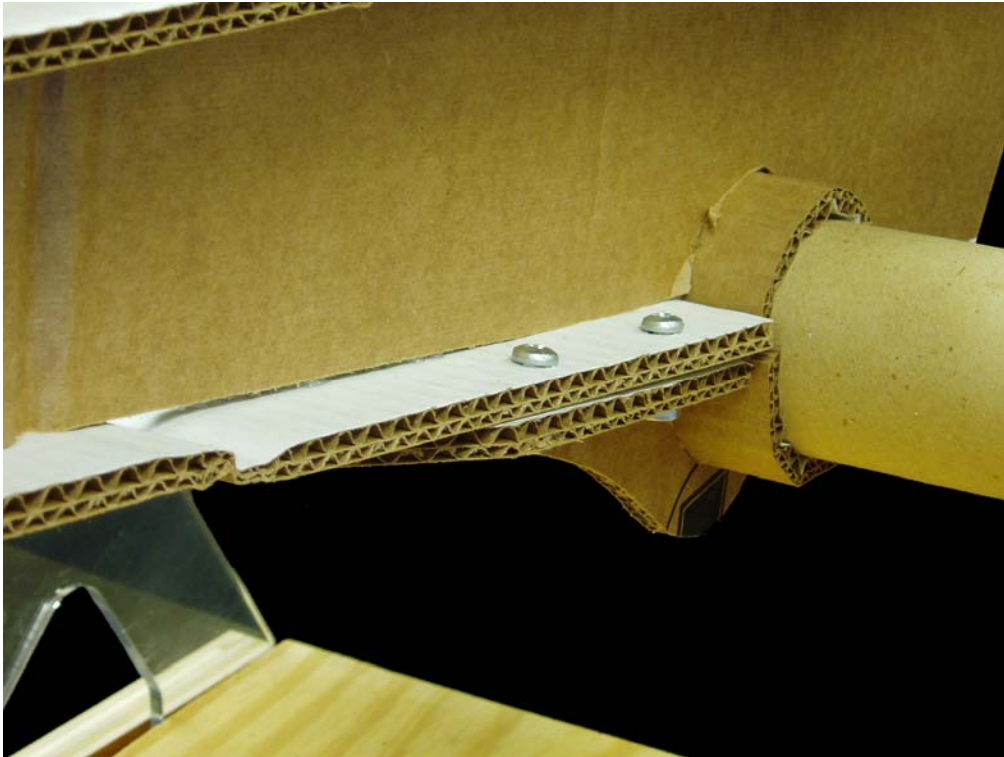

Figure: 6-18 – Diagrammatic Model – Roof Slice Attachment Detail.

Conception or More Accurate Representation

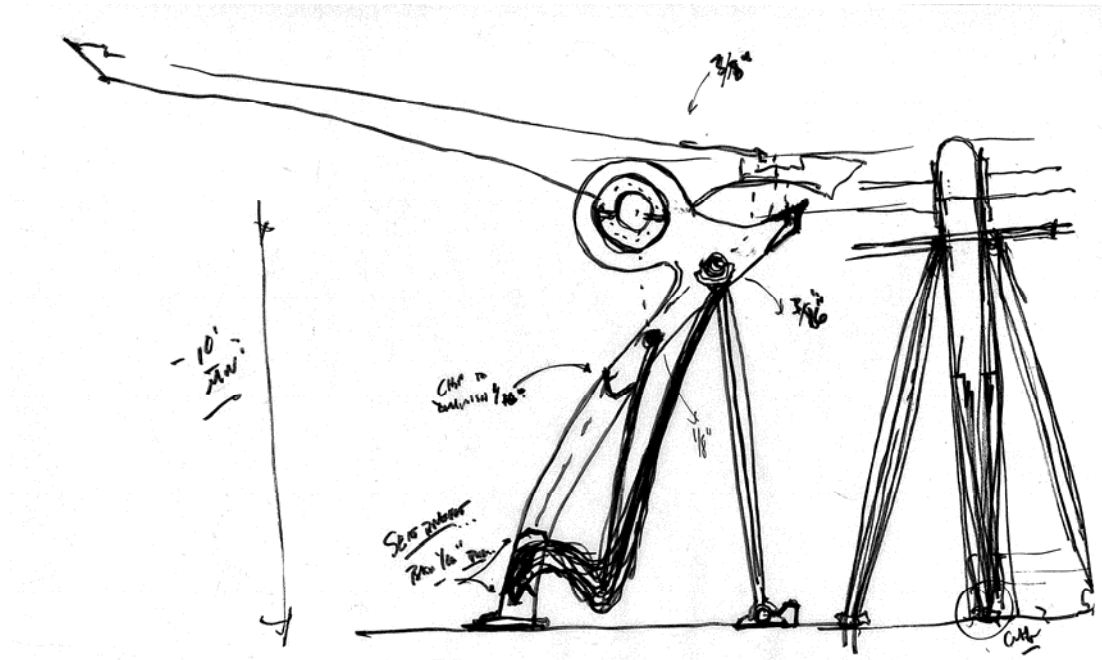

Figure: 6-19 – Conceptual Sketch – Tripod Based Steel Stop Assembly.

Another version of the four bay station stop would then be assembled based on these ideas about steel construction. A gestural sketch above shows how a tripod assembly would be comprised of one leaning columnar element which would then be supported by two smaller legs. The leaning columnar element would then, in turn, support a tube steel element attached with a circular end flange and would somehow be bolted in place in the field. The roof slices (rafters) would then be attached to this tube as seen in the previous diagrammatic model. Also of note in this sketch, were ideas related to incorporating seating along side and under this canopy structure. Modular systems could be used here to attach seating elements if needed. Pins or other adjustable connections could be used to allow for variety in length, position, or size of these seating elements. Sleek shapes and profiles could be exhibited to begin to relate all the elements of the system together. Lastly ideas about integral gutters and

downspouts that would be concealed within the columnar elements were briefly explored.



Figure: 6-20 – 4 Bay Station Stop Model – Steel Construction.

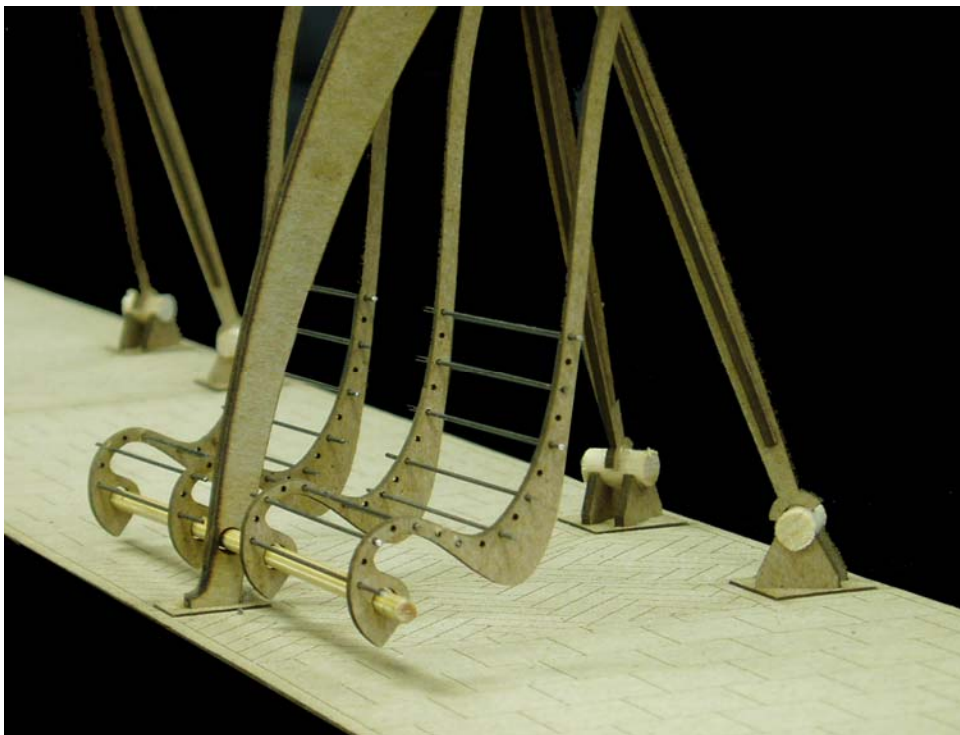

Figure: 6-21 – 4 Bay Station Stop Model Detail.

Still lacking after this exploration however were the connections of all of the tripod assembly members, their connections to the ground, and a finite roof attachment method that would be feasible based on the light-weight polycarbonate material systems that ideally would be used. More research into that material and the interactions with the steel roofing elements will be explained in a later section.

One Material Chosen

For Uniformity of the System, Single Material Preferred

At this point a decision was to be made regarding the identity and uniformity of the purple line system. Based on public usage in typically high stress conditions steel would probably be preferred to wood in simple material wear conditions. Steel would probably be easier to maintain and after the initial developments presented here, steel would allow for more flexibility in design interventions. Wood can be great for sustainable practices, but prefabricated steel elements may give the look of a new-age modern, technologically advanced system that the purple-line should exhibit. The steel structure as well seemed to have a sleekness and lightness in development that spoke a good deal about structural efficiency.

A decision was made to pursue steel structures for the rest of the implementations from this point onward. With new technology regarding the construction of steel elements, a level of design can be tested to explore forms that could most likely not occur with wood. As well, the author wished to explore construction systems that

were not typically used in past investigations. This material would become the basis for the rest of the station stops, as well as the majority of the structural material for the future additional system implementations.

Elaboration of Steel Station Stops

Single Sided Stop Progression

Once the material of steel was chosen and a general stop configuration based on the previous iteration, more advanced developments would take place. First the tripod would need to be worked out with regards to assembly, actual connectivity between the ground, and the members making up the tripod itself.

Here digital means would allow for exploration of more complicated forms to describe this system. When thinking about constructability of these forms as cut sections from flat sheets of steel, folded into place, welded where the corners met, and then ground smooth and painted, almost infinite forms and shapes could be possible to make up the majority of the columnar elements forming the tripods. By using subtractive modeling and boolean operations to take the intersections of side and front elevations, a more elaborate and exciting tripod could be created.

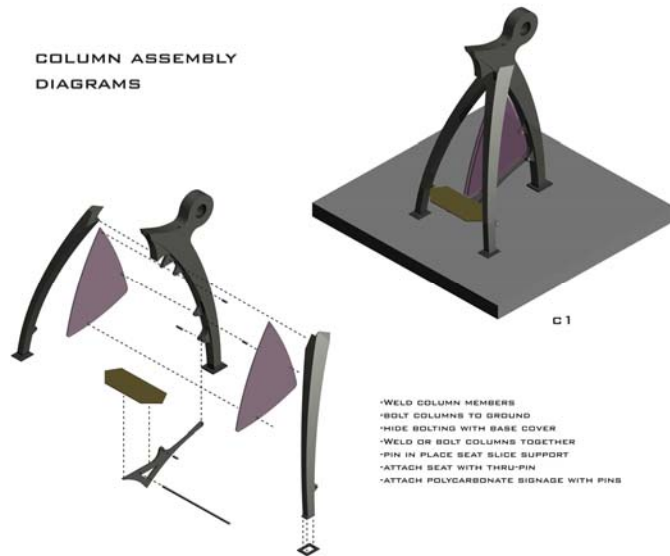

Figure: 6-22 – Tripod Assembly Diagram.

Many iterations of these tripods were developed, each originally imagined as being made up of simple hollow tube elements (basically) that would somehow bolt to the ground and weld together near the top of the structure. Anthropomorphic feet emerged at some stages in an attempt to make the ground connection appear light, as if these elements were simply resting on the ground. This connection would take some more work later in the process to fully resolve but early attempts to hide this column-to-ground condition was the original intent.

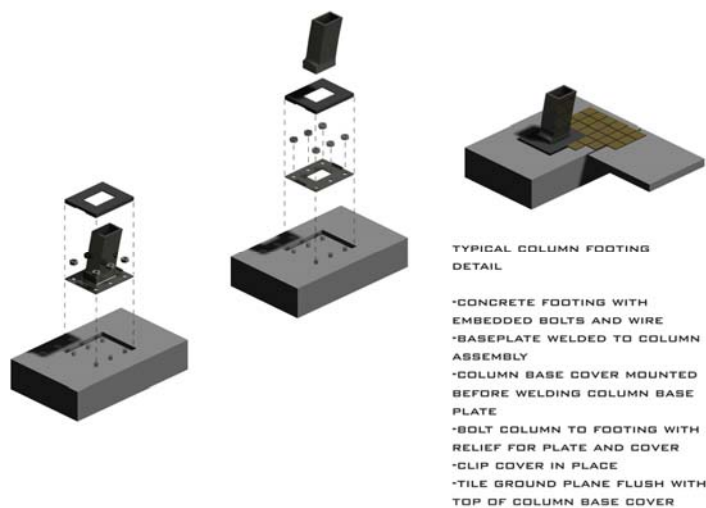

Figure: 6-23 – Early Concealed Base-to-Ground Connection.

During these stages of a single-sided stop design, many other considerations were explored. While still adjusting the exact shape and proportions of the roof slices, the basic principles employed earlier would remain for the upper portion of the roof structure, that being prefabricated and later bolted to the pre-welded flanges to surround the tube steel beams. Additionally however, other issues would appear dealing with other types of shelter for this station stop.

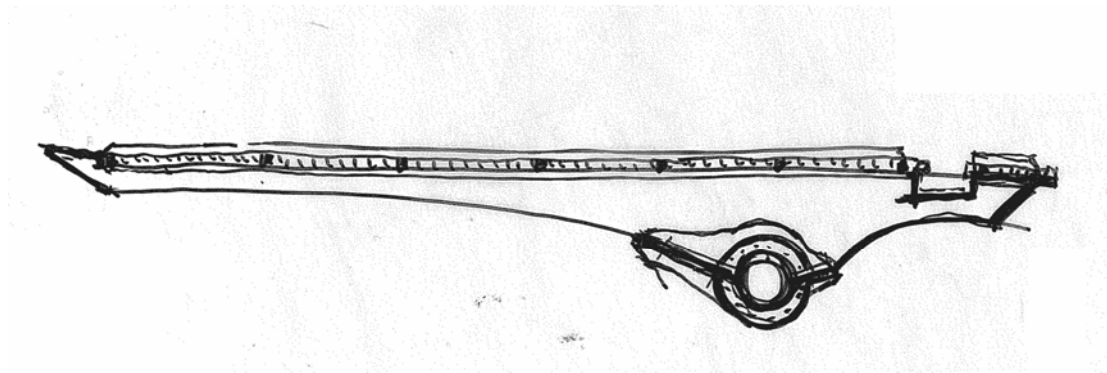

Figure: 6-24 – Refined Gestural Drawing of Simple Roof Slice.

Protection from falling rain may be the most typical situation of adverse weather, however protection from wind and other horizontal weather would also be recommended. Creating ‘side walls’ for this stop would take some work, but again the tripods would solve many of these inherent design issues. These zones of structure could also integrate vertical elements to provide for a multitude of functions. Signage mounts could be added to the legs and this signage would indirectly become an element of side shelter. As well, integral seating could be introduced in this zone.

As advertising constantly seems to be a generator for this type of public infrastructural element other means for display of signage may also influence the

design of these elements. In addition to overhead shelter and side shelter, rear shelter would also be desired. This rear shelter could also be a place for advertising signage, or simply signage to display scheduling information and track routes. One approach to dealing with this additional type of shelter created an elongated roof slice which would basically wrap the enclosure and become a rear wall support as well as a roof structure. Later even these wrapping slices could take shape into additional seating elements and grow other functions depending on the exact location of these station stops or the specific needs of each structural bay. These seating elements would ideally incorporate a softer surface element typically depicted as wood slats or another naturalistic system of glued-laminates.

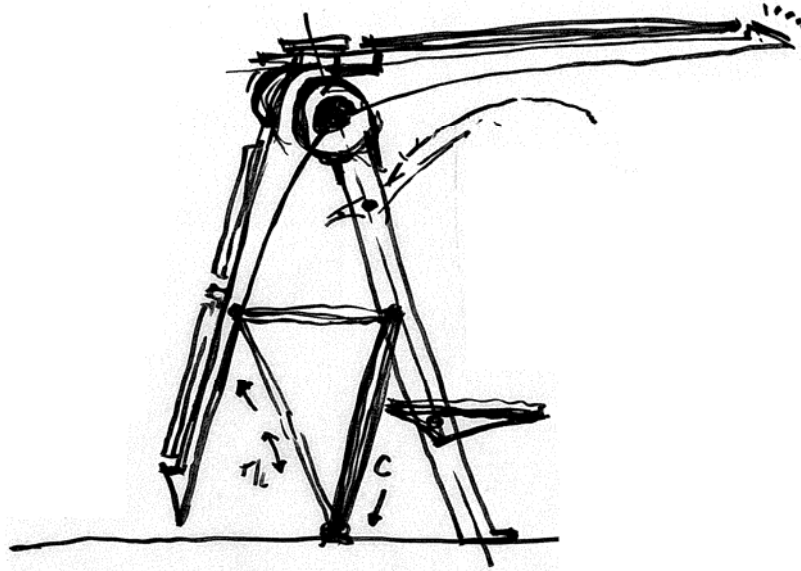

Figure: 6-25 – Wrapped Roof Slice Configuration.

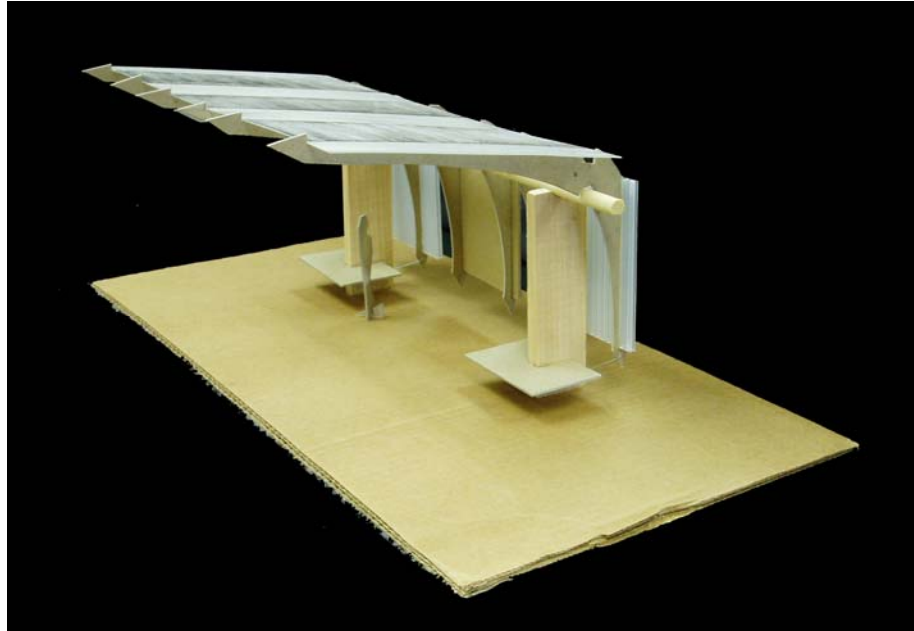

Figure: 6-26 – Wrapped Roof Slice Conceptual Model.

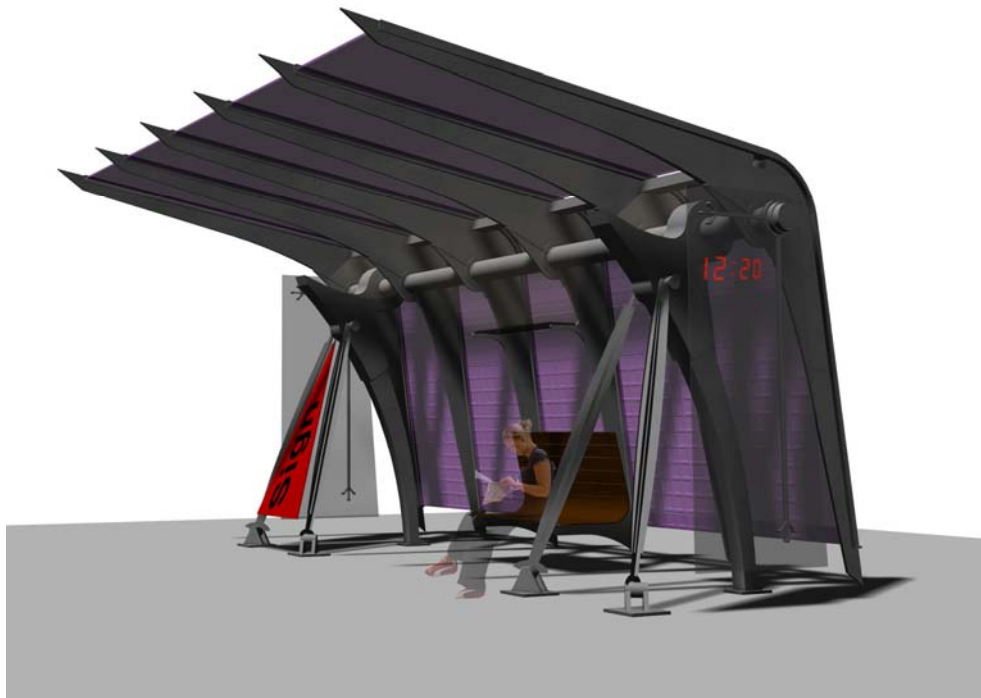

Figure: 6-27 – Wrapped Roof Slice Digital Model Incorporating Advanced Tripod, Signage Mounts, Integrated Seating Elements and Digital Readout Screens.

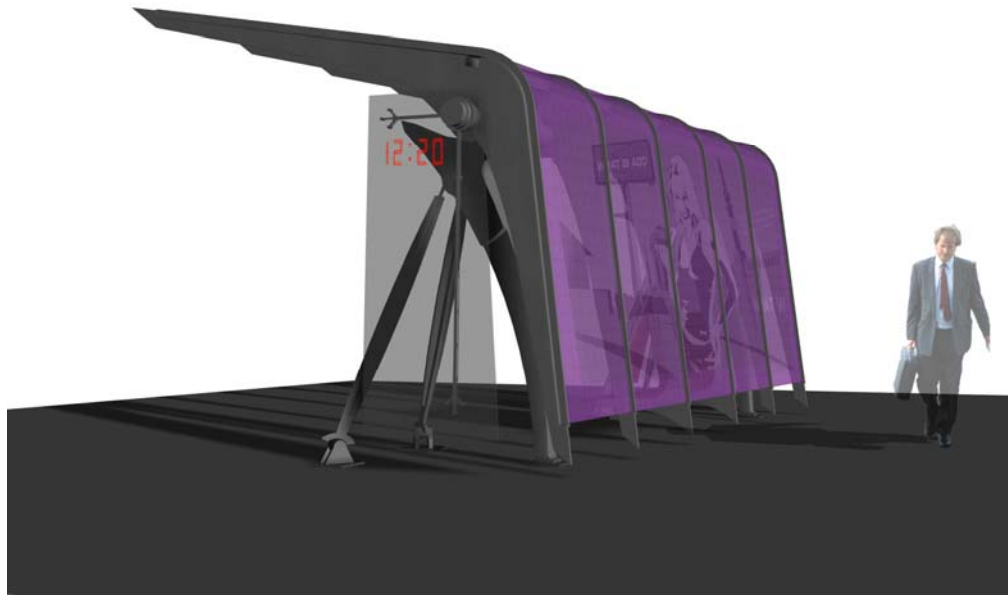

Figure: 6-28 – Wrapped Roof Slice Digital Model Incorporating Screen Printed Advertising.

The tripod columns would take on further development to adjust to topographic conditions with the addition of a large seating element. This fairly boxy seat could be the mediator between subtle slopes, but could also house things like batteries that might collect energy from solar photovoltaic laminate on one possibility of roof surface material. This exploration was halted quickly however as conflicting languages between these mediators arose. Issues of topography would not be furthered as ideally these station stop platforms would be very flat as to accommodate all types of accessibility. However further seating elements nestled within the zone of the tripod would continue through the rest of these station stop iterations.

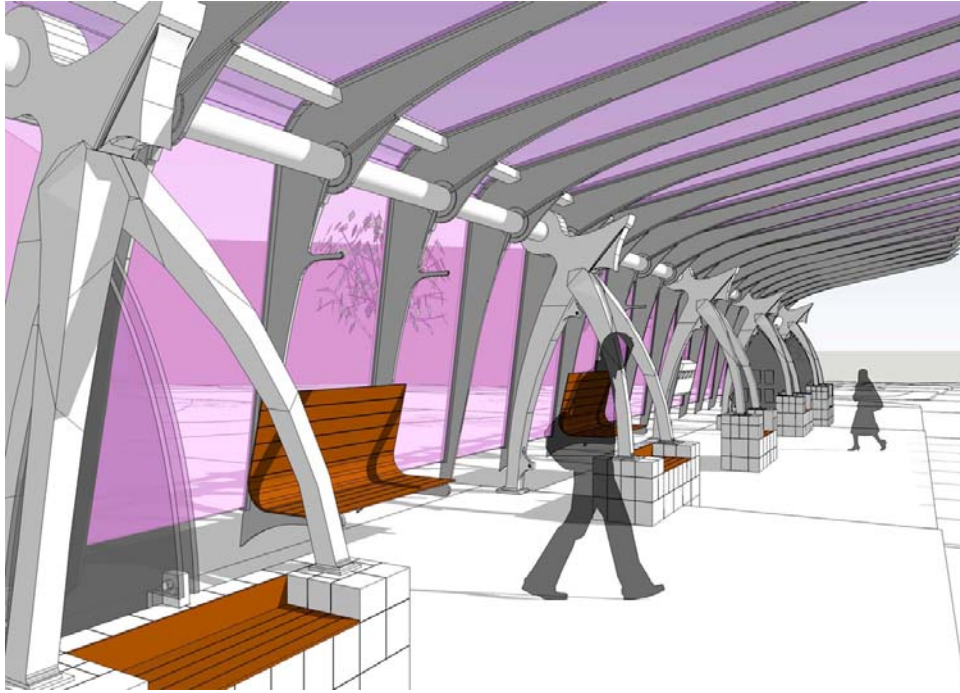

Figure: 6-29 – Wrapped Roof Slice Digital Model Incorporating Topographic Mediating Seating Element and Organic Roof Slice Transformations.

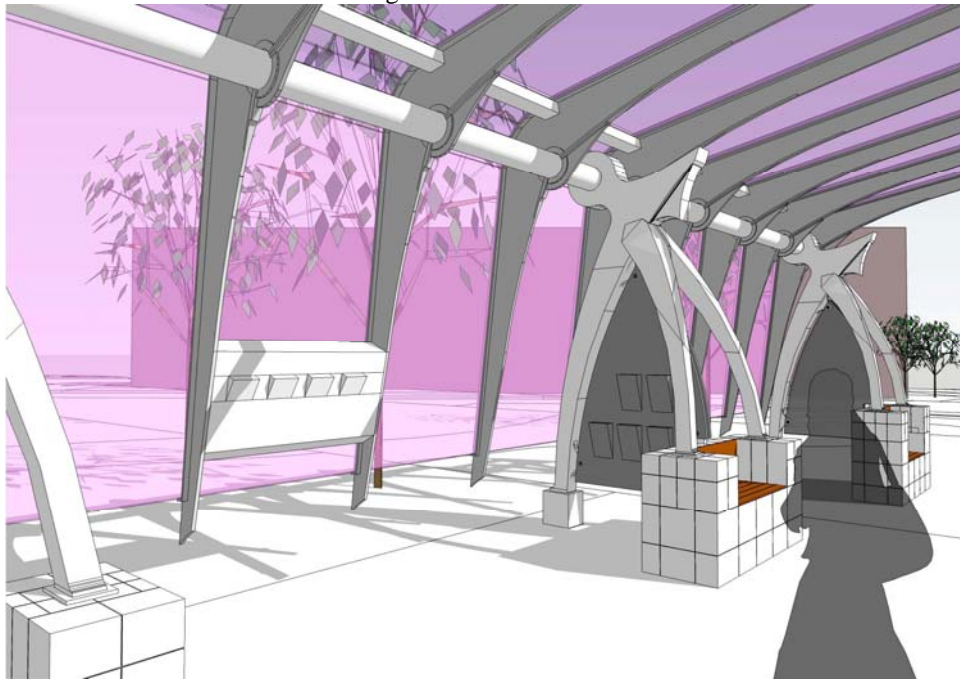

Figure: 6-30 – Wrapped Roof Slice Digital Model Incorporating Topographic Mediating Seating Element and Other Modular Insertable Features such as Pamphlet Holder or Ticketing Machine.

The tripod columns, again based on their hollow elements, could support wiring for lighting and other technological requirements. Integrated lighting at the top of this tripod could up-light the roof material and down-light the zones of seating within the tripod.

Again for the actual material for these station stops, a type of polycarbonate would be preferred. This material could be colored while still providing varying degrees of transparency. This could be a great benefit to block UV radiation from above, but allow for more transparent conditions at eye level. Certain technologies available can also screen images onto the outer surface of polycarbonate materials. This could easily provide a sleek method for light-weight panels of interchangeable advertising. Like the roof structure, there are only a few necessary parts to actually install this type of system. There are simple framing gaskets and relatively minimal surrounds to these large easily cut panels of material. The material itself could be directly drilled and bolted to the supporting structure but a framed panel which then would be fastened or clipped to the supporting structure would probably be preferred. Lastly this material could also incorporate laminate layers of either photovoltaic elements, or even be infused with digital displays or LED screens. As low-tech as constantly updating, computer controlled advertising, to GPS induced train monitoring systems could feasibly, eventually be incorporated into panels of this material. Starting at about 1/7th the weight of glass, adding LED's or other display material will still keep this shelter/advertising/informative system of paneling strong while easily supported by the structure employed here.

The roof slices would take on a variety of shapes due to different functions throughout this process. Some would simply provide shelter from above while supporting the roof. Others would fold around past their tubular attachments and turn into protective elements from the rear of the stop. Some even turn into seating elements, while larger slices become double sided supporters of large butterfly roofs. As well, these slices could incorporate an attachment position (here mostly illustrated as a circular notch) for the overhead wires that would power the train cars. By being long enough to protect passengers from weather while accessing the trains, these slices might as well cover a little more of the train and become a location for this additional function. Lastly here the lower flanges of these slices could become locations for mounting other elements necessary in a busy transportation system. Signaling apparatus, route directional signage, train locator screens, or other implements could easily take shape and appear to form from this somewhat organic language of malleable metallic pieces.



Figure: 6-31 – Final Single Sided Stop Elevation Showing Incorporated Display Mount, Wire Support Location, Tripod Zone Signage and Seating, Sleek Base Detail, and Organic Wrapping Roof Slice.

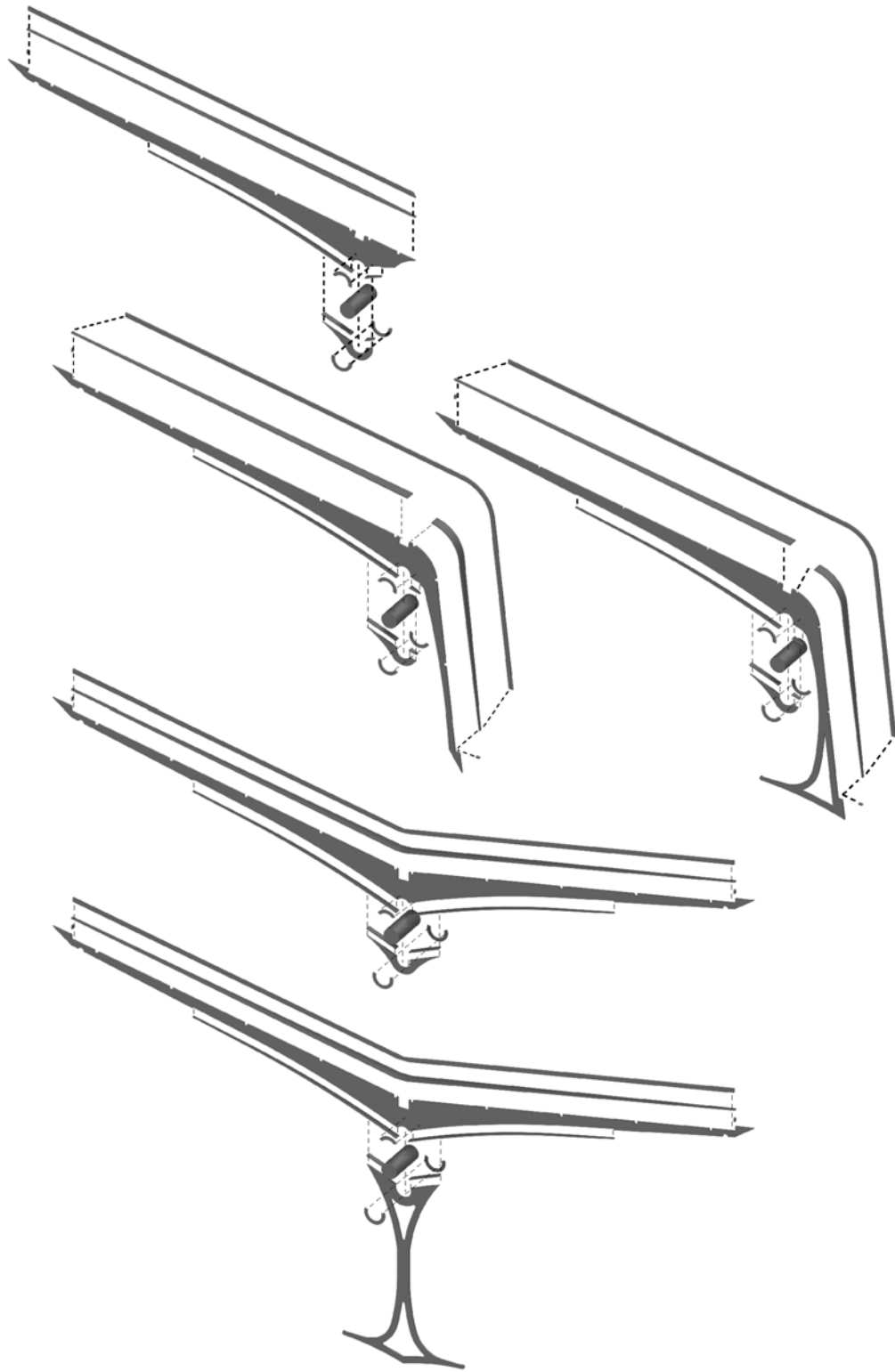

Figure: 6-32 – Roof Slice Variations and Assembly Procedures Diagram.

Regardless of shape or size they are assembled in the same fashion. This method would prefer large sheets of rolled steel, which would be cut with a water jet or other computer controlled device. These cut pieces would become the webs and flanges and then all of those pieces would be welded together. This process would allow for a precision in construction and based on technology, and computer algorithms that could arrange these pieces on the sheets of steel, would create an efficiency in prefabrication unheard of even ten years ago. These templates for cutting could easily be repeated and many of these infrastructural stops could then be rapidly produced.

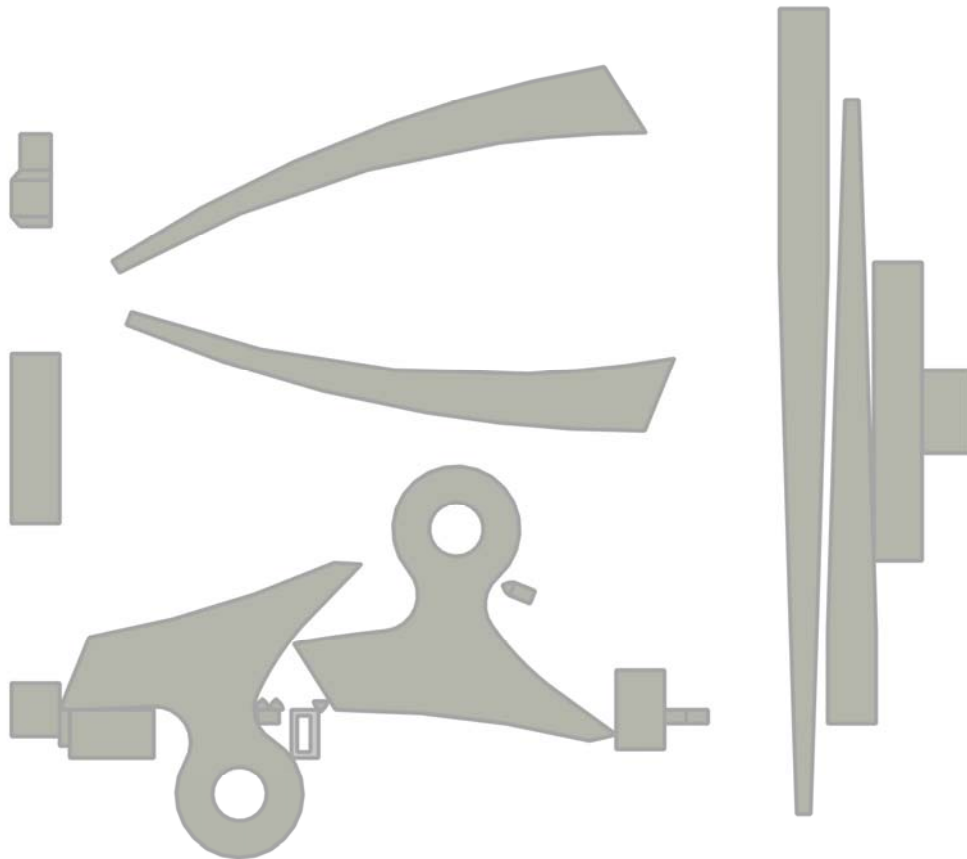
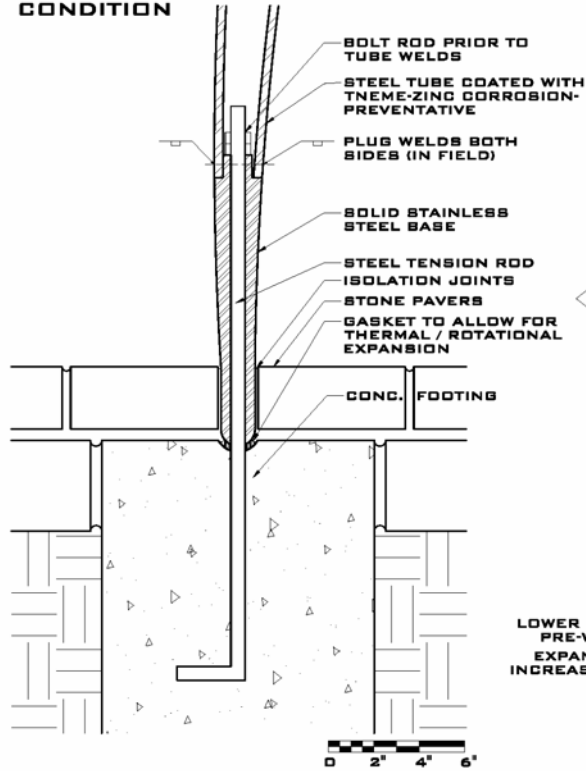

Figure: 6-33 – Tripod Column Sheet Templates for Water Jet Cutting.

A final version of this station stop tripod would incorporate a sleeker base-to-ground connection. In an attempt to make the tripods seem to barely touch the ground, a hidden solution was developed. Instead of having a tubular system of folded flat pieces go all the way to the ground, a solid base piece was implemented. This solid piece could be fairly small as too appear less intrusive and could minimally make contact with a structural footing. However, this solid base piece would probably have to be stainless steel as to prevent issues of corrosion and it would probably have to contain a tension rod that would be embedded deep within a foundation. Acting as a mediator between this stainless steel base and the foundation would have to be a gasket that would allow for a bit of thermal expansion and rotation and in essence create a pin joint at this location. Above this solid base element, the tube would reappear once an appropriate thickness for this to occur was reached, and the tube could simply be plug welded to this solid base and again, as a finishing element, the joints could be ground smooth and painted. This version of the base connection was preferred and would continue into the final iterations of the other station stop configurations while issues of drainage and electrical supply took a back seat.

Lastly the tube to column connection would be produced by first incorporating threaded spacers into the folded column assembly. Then tube end flanges could either be bolted to other tube end flanges through these spacers or simply be through-bolted to the column assembly at an end bay condition.

**TYPICAL COLUMN
LEG-TO-GROUND
CONDITION**



**TYPICAL SLICE TO
TUBE CONNECTION**

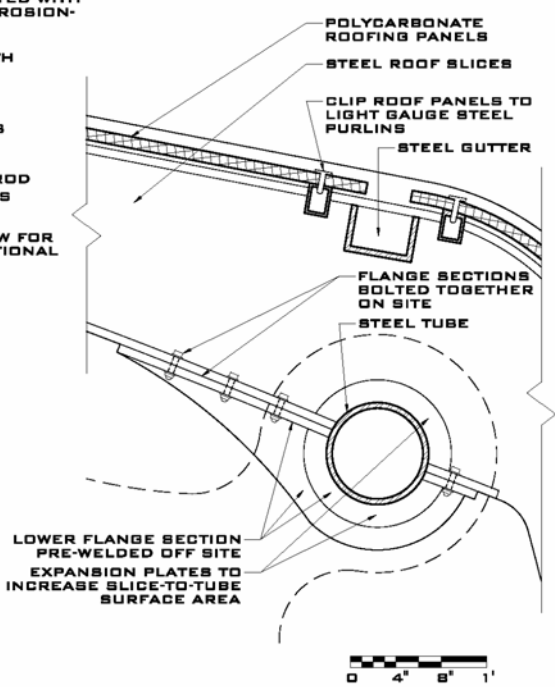

**TYPICAL TUBE TO
COLUMN CONNECTION**

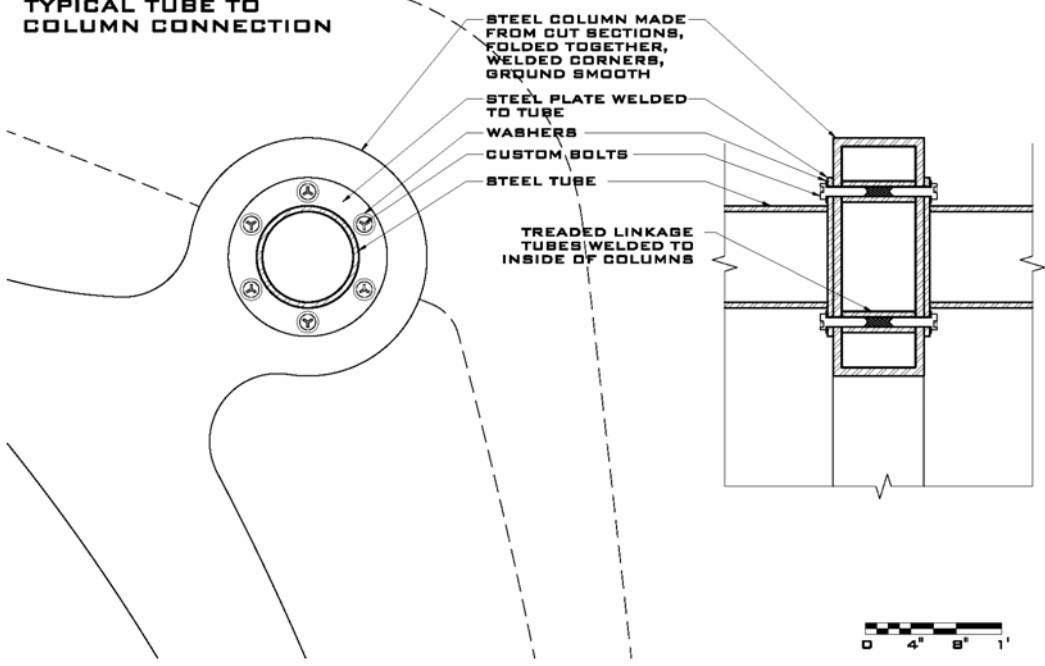

Figure: 6-34 – Base-to-Ground Detail, Slice-to-Tube Detail, Tube-to-Column Detail.

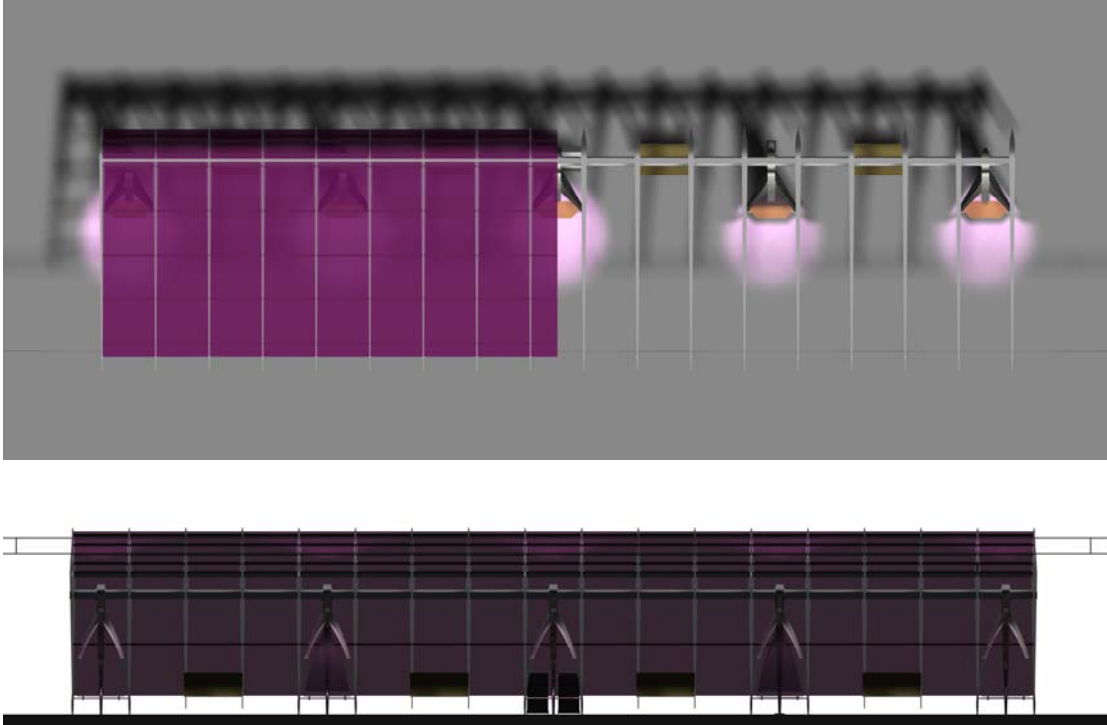

Figure: 6-35 – Four Bay Final Single Sided Station Stop Plan and Front Elevation.



Figure: 6-36 – Final Single Sided Station Stop Perspective View.

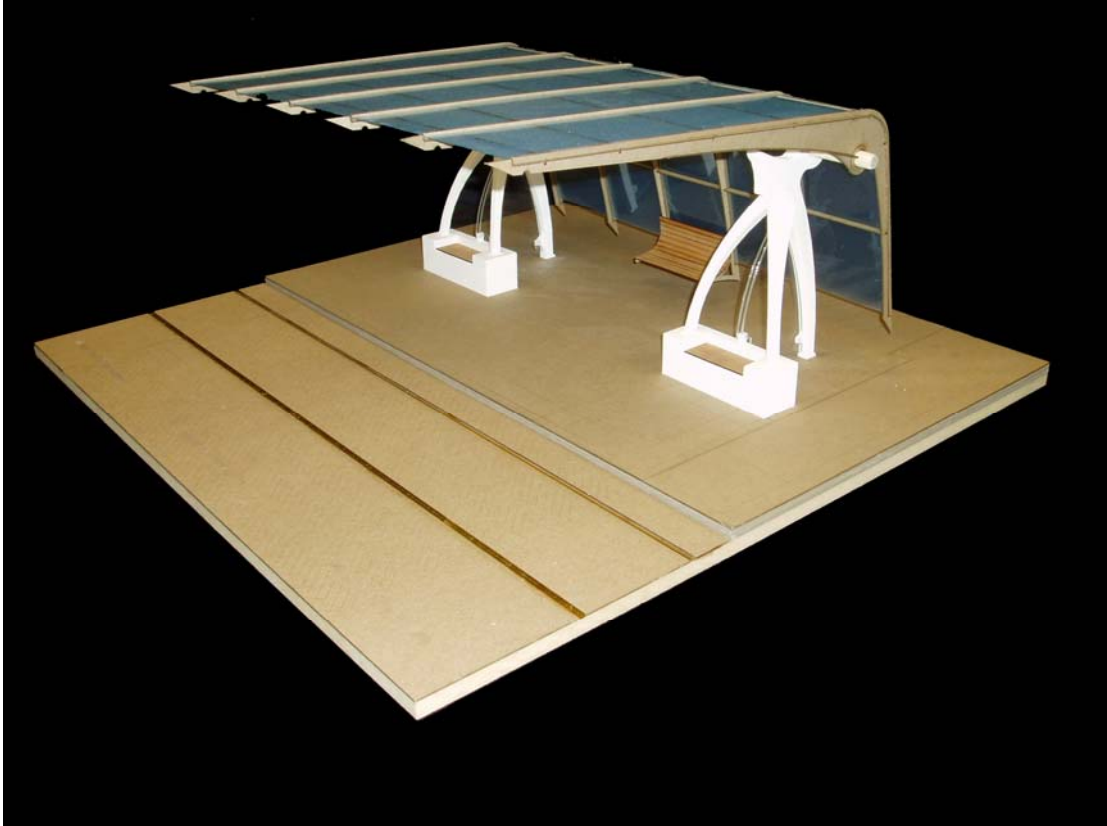

Figure: 6-37 – Final Single Sided Station Stop Model Incorporating Slightly Older Means of Meeting the Ground with Topographic Mediating Seating Element, Including Rapidly Prototyped Tripods.



Figure: 6-38 – Final Single Sided Station Stop Model, Elevation View.



Figure: 6-39 – Final Single Sided Station Stop Model Detail View Showing Integral Signage Mounts and Morphing Wrapped Roof Slices Turned into Seating Elements.

Double Sided Stop Progression

The developmental process for the double sided stop came after many of the issues were solved for the single sided stop. Ideally, for reasons of uniformity in the system, many of the same details could be employed in both systems. The column base detail for example could be the same in both systems. As well, the roof slice-to-tube connection could easily stay the same. As seen in figure 6-30, the slices would simply be modified to cover both sides of the tracks and stem out from a middle-platform set of columnar elements.

In this case however it seemed that a tripod might not work well for a two-sided setup. The tripod gave nice hierarchy to a one sided system where a seating zone

could again occupy a trackside position. Here however a ‘quadripod’ element would be transformed from the ideas inherent in the tripod columnar assembly. Elements of seating, signage, and lighting would be included. The connection ideas to the other structural elements would also remain the same. However a new mediating piece would be developed to bridge the gap between two mirrored sets of tripod legs which would form the quadripod. This piece and the assembly of all of these pieces would follow the same sheet cut steel system of the tripods. Transformation and application of this system proved to follow suit once the columnar assembly was designed.

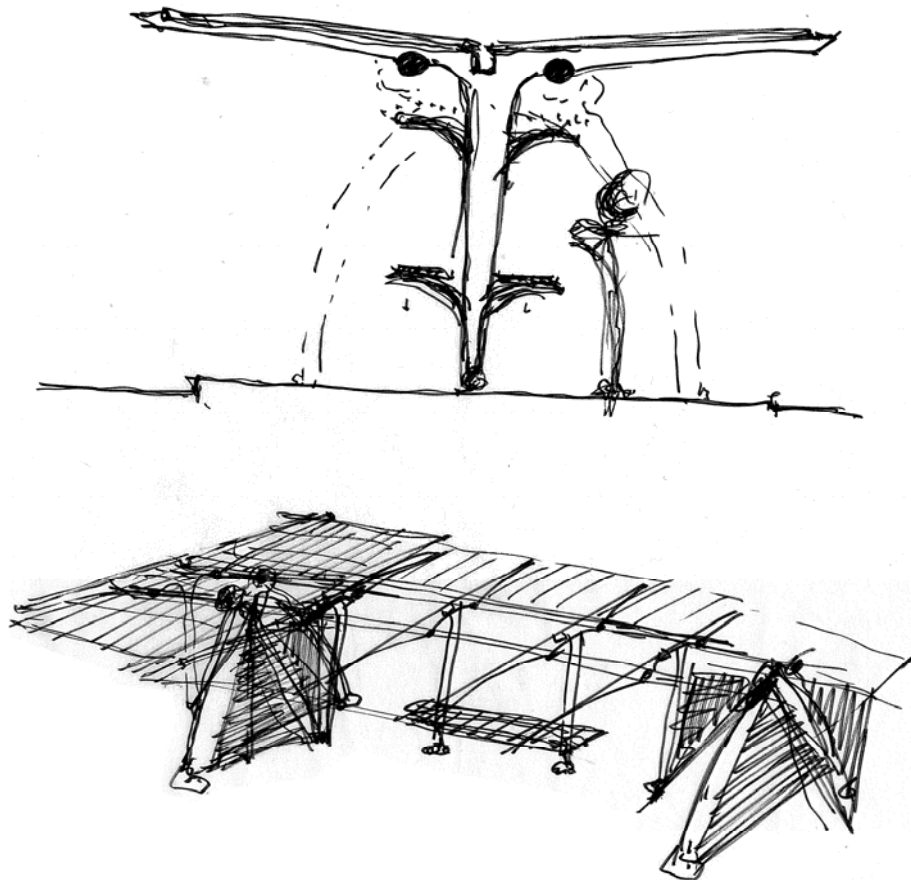

Figure: 6-40 – Initial Conceptual Diagrams for Double Sided Stop.

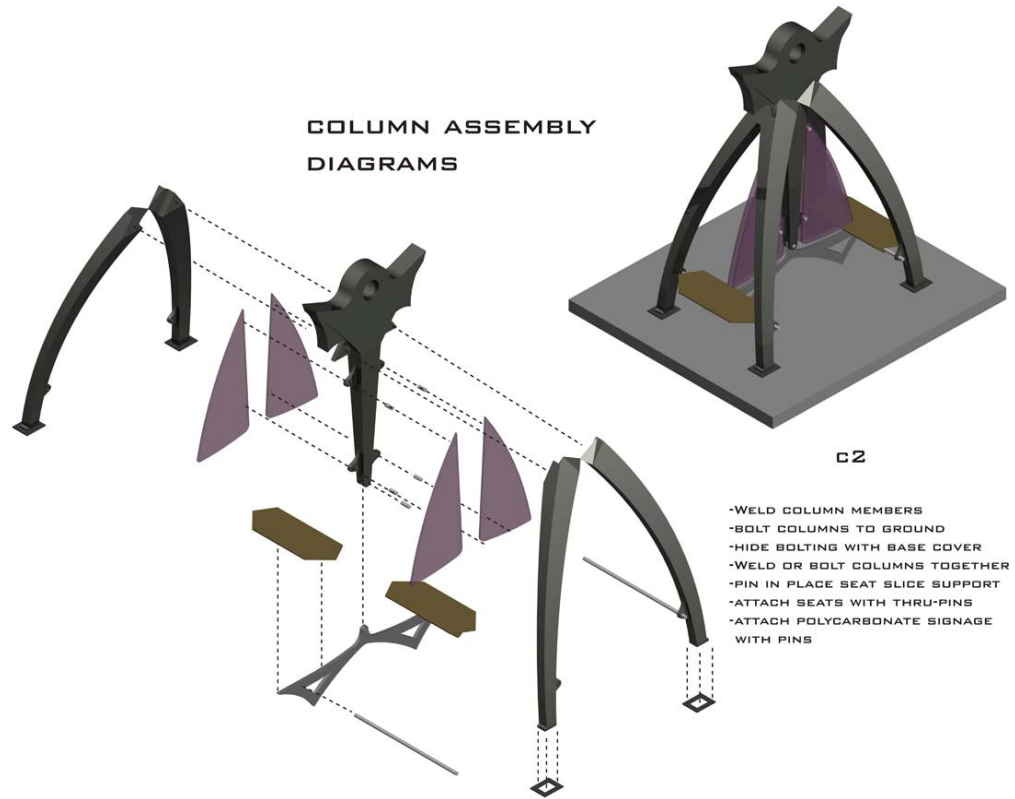

Figure: 6-41 – Early Quadripod Assembly Diagram with Two Sided Seating and Integral Signage.

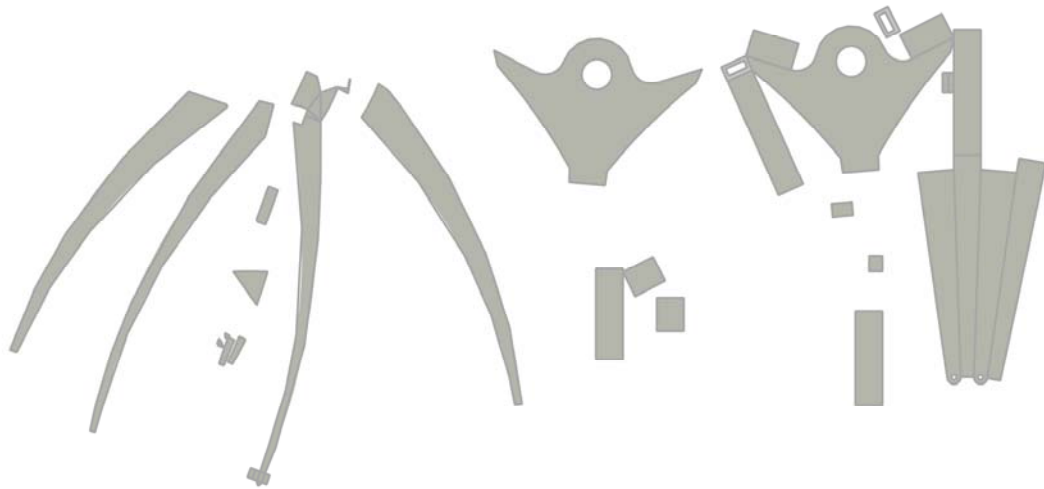

Figure: 6-42 – Final Quadripod Central Post Sheet-Cut Template, Tripod Leg Sheet-Cut Template.

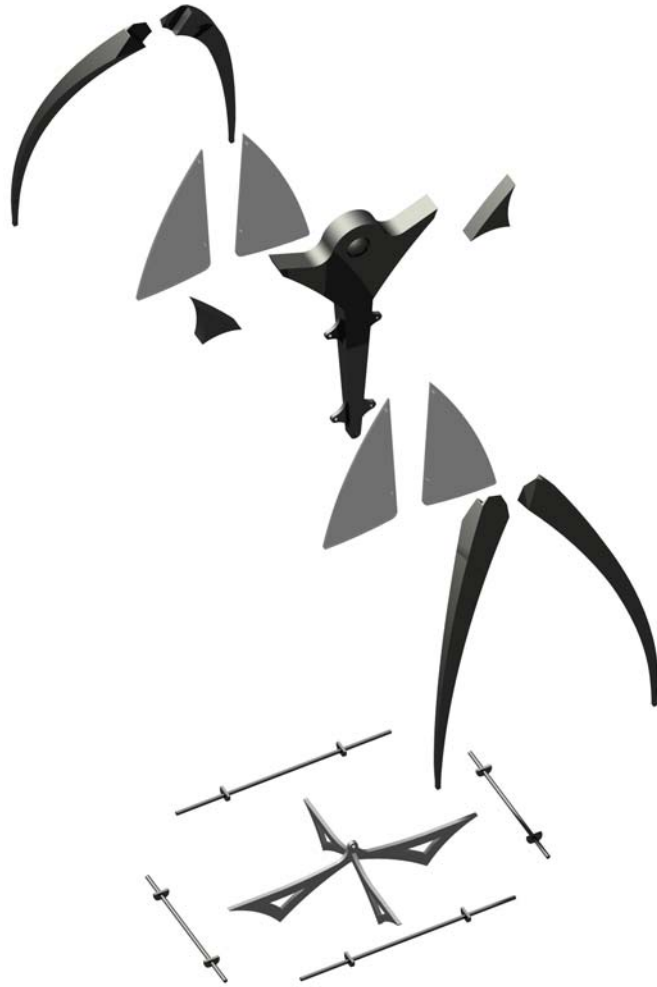

Figure: 6-43 – Quadripod Final Assembly Diagram.

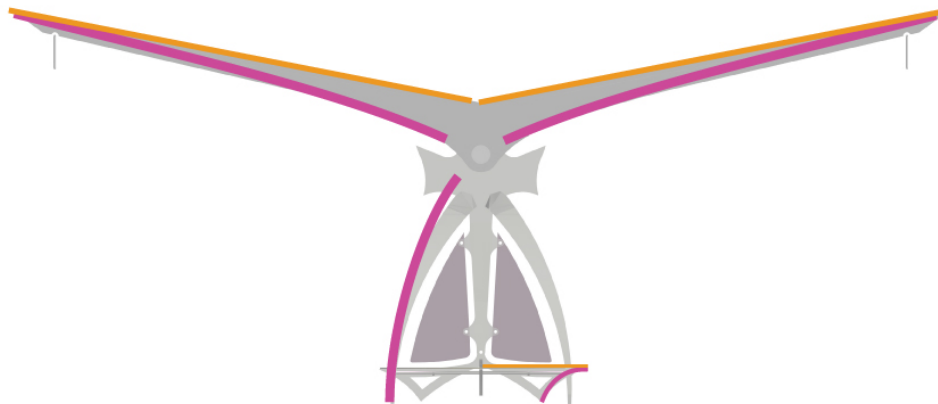

Figure: 6-44 – Double Sided Stop Force Diagram Generator Reminders.

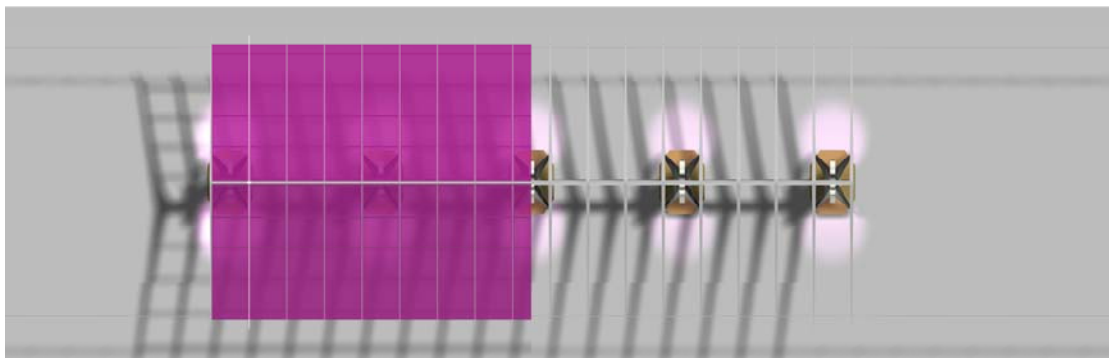
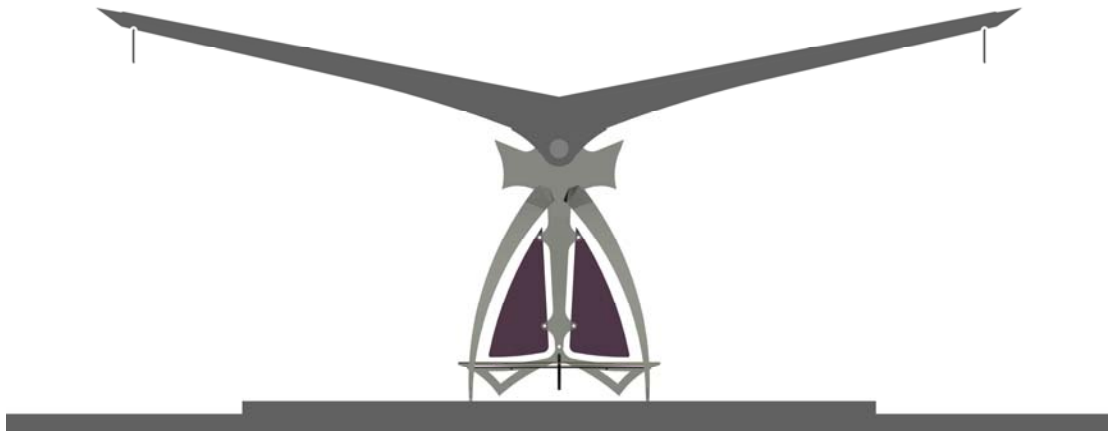

Figure: 6-45 – Double Sided Stop Final Orthographic Representations.

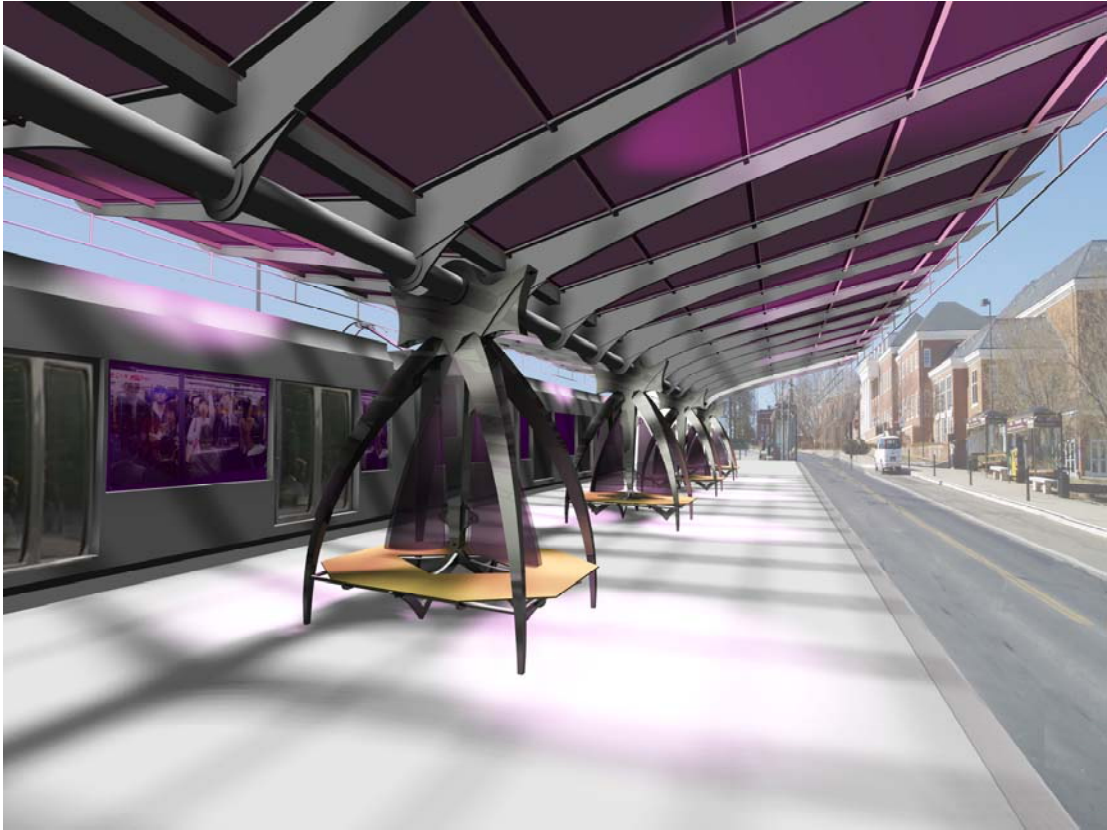

Figure: 6-46 – Double Sided Stop Final Perspective View Incorporating Sleek Base-to-Ground Detail and 360 Degree Seating Elements.

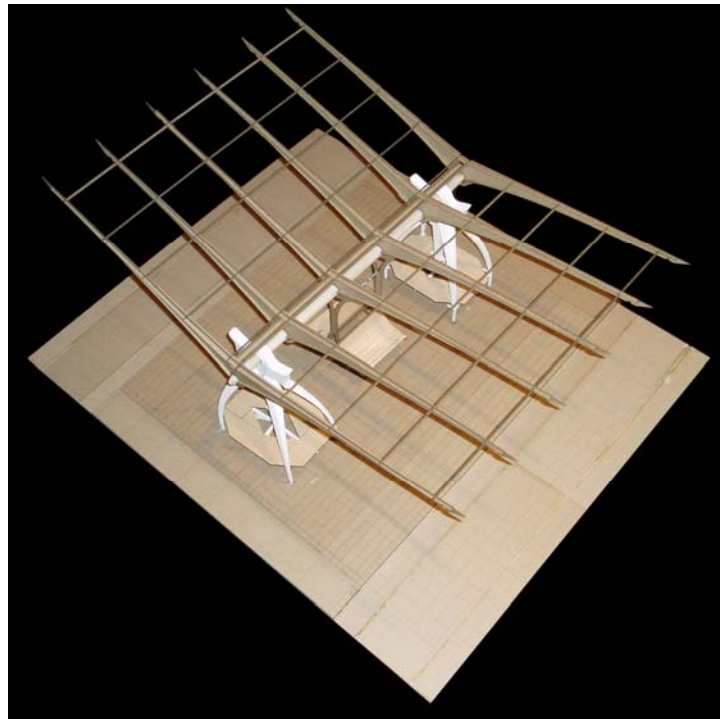

Figure: 6-47 – Double Sided Stop Final Model, Aerial View.

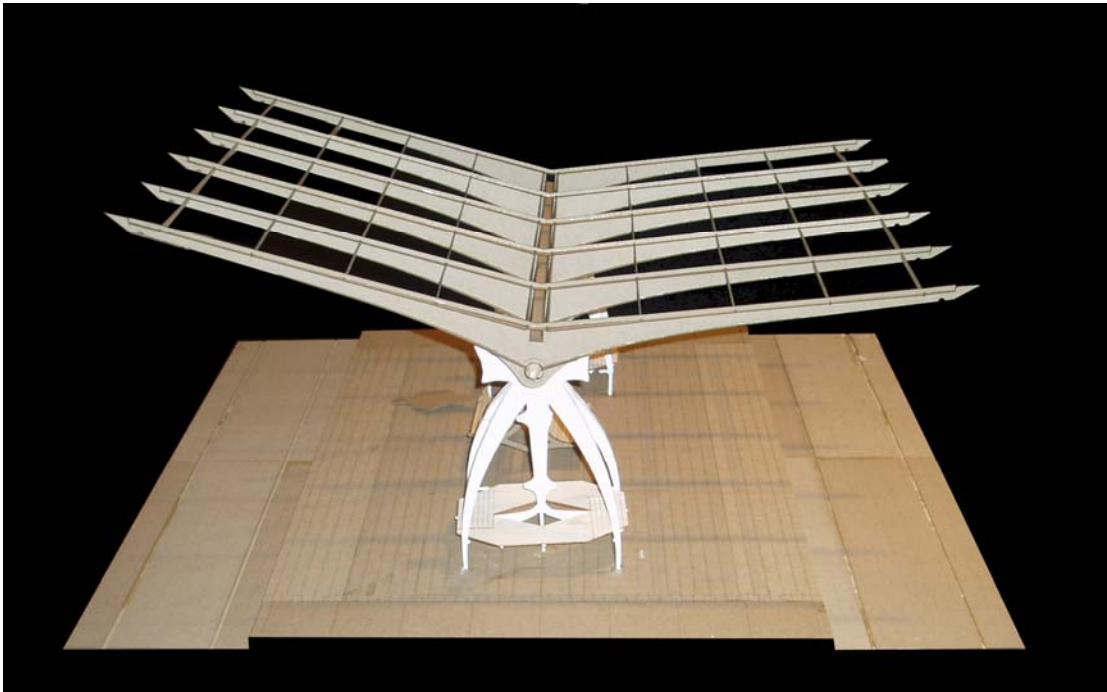

Figure: 6-48 – Double Sided Stop Final Model, Elevation View.



Figure: 6-49 – Double Sided Stop Final Model, Roof Detail.

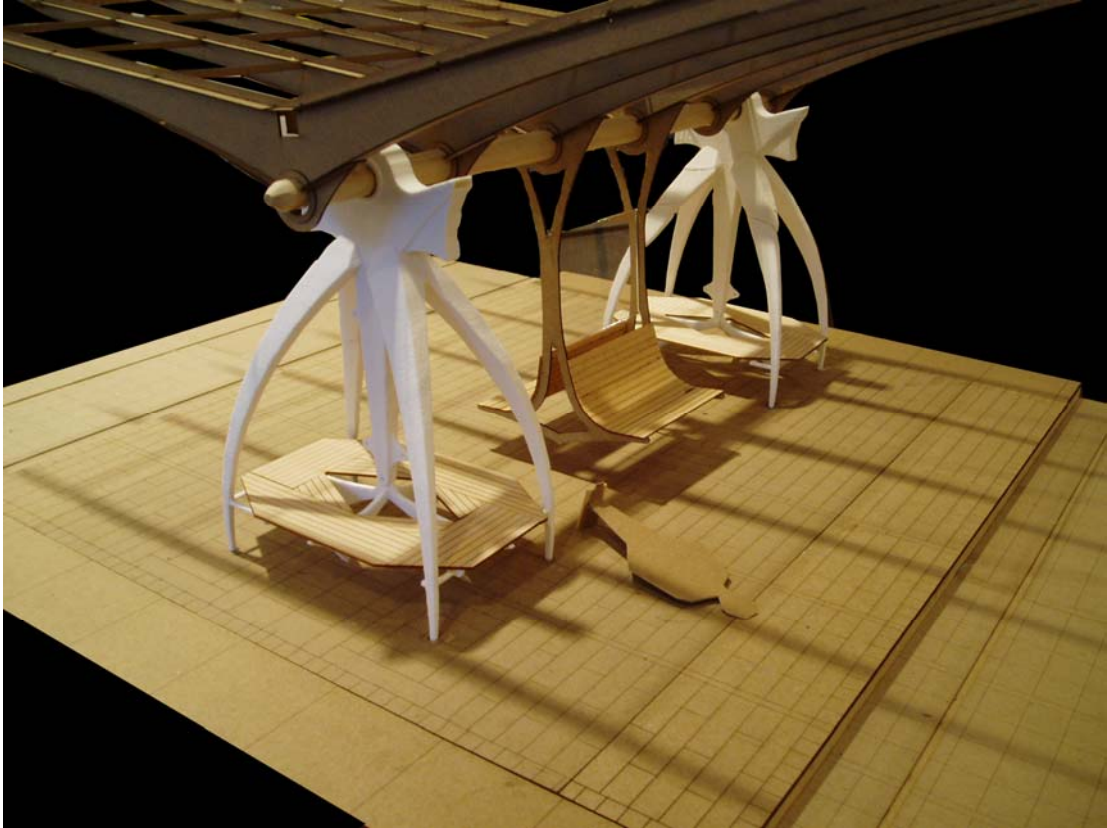

Figure: 6-50 – Double Sided Stop Final Model, Perspective View Incorporating 3D-Printed Quads.



Figure: 6-51 – Double Sided Stop Final Model, Perspective View.

Single Sided Small Stop Progression

A final version of the station stop would be required to fulfill a majority of infrastructural situations. This would be a minimalist version of the single sided stop configuration. This stop might be located near or in place of a currently existing bus stop, probably being placed within an urban context where an entire ideal train-car-based-four-bay-station-stop would not fit. There potentially would be no need for rear shelter as sidewalk conditions might be tight. Additionally if located in front of retail locations, a more transparent environment would be preferable to vendors who had this type of stop located in front of their stores.

Ideally these structures would draw people to them, and hence increase the potential for people to notice the adjoining retail establishments, but in case worrisome tenants would put up a fight for these structures to be erected, concessions have been made. Seating in these locations could actually turn to face the street-side vendors and based on the tripod configuration at these instances, the lighting could actually help to light the stores at night. Typical side and overhead shelter would be in the same language as the rest of the station stops, but a less intensive wrapped shelter may also be developed. This type of stop location would be the least visually intensive of these structures and could be erected in a variety of tight urban conditions. Likewise, there would be no vertical slice elements as to keep pedestrian movement as unhindered as possible.

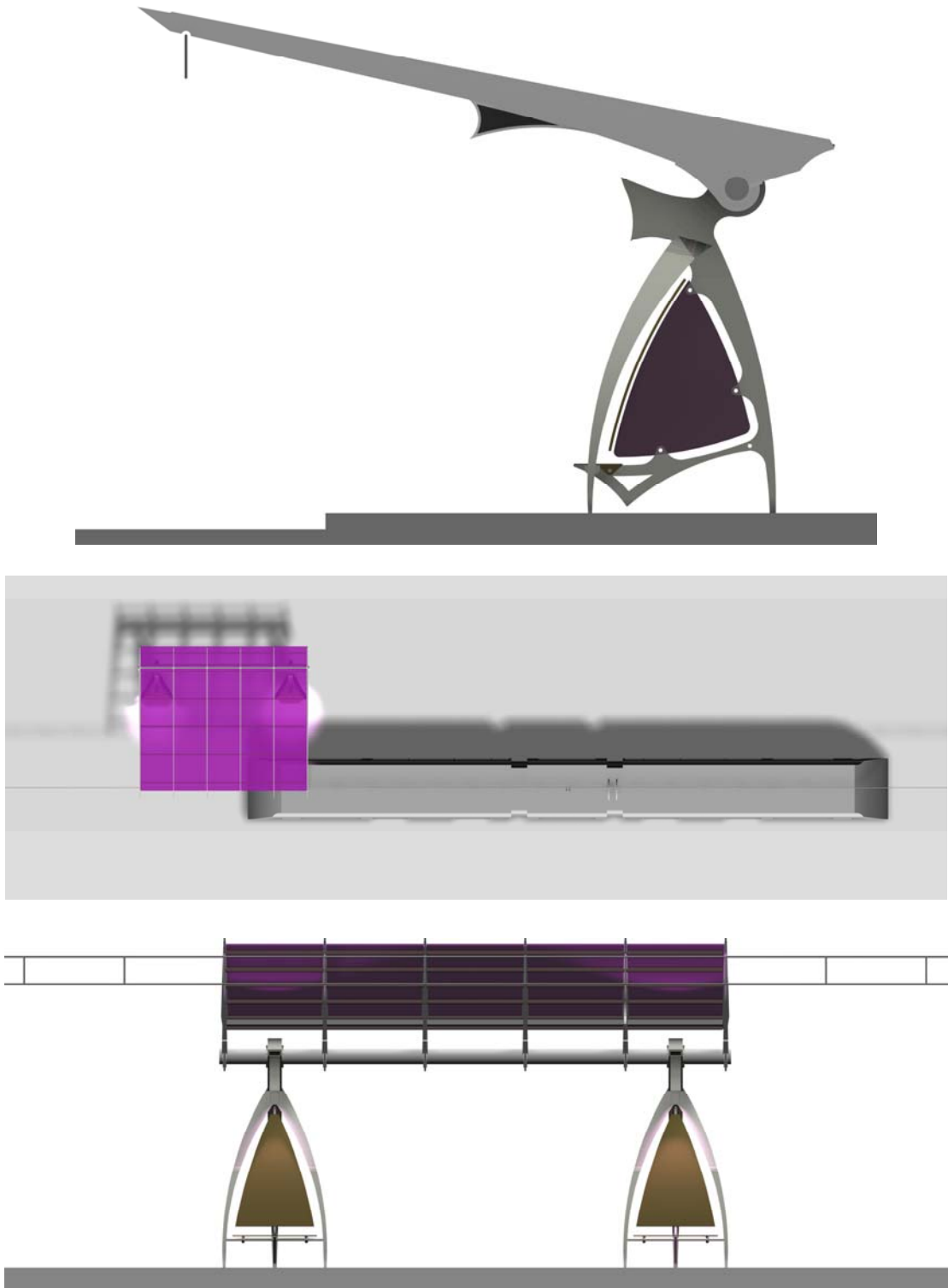

Figure: 6-52 – Single Sided Small Stop Orthographic Representational Drawings.



Figure: 6-53 – Single Sided Small Stop Perspective View.

Chapter 7: A New Kit-of-Parts Realized

Other Details for an Infrastructure Needed

List of Detail Elements that will be Explored

Many elements in actuality make up an infrastructural system. Although the station stops and weather-protecting canopies may become the major iconographic elements, many smaller items would also need to be developed in order to constitute inaction of an entire system. This list of additional elements would in actuality constantly be changing as new items were needed, after new advents in technology occur, or simply when the need for rehabilitation of existing elements arises. However through a consistent set of guidelines that will be elaborated upon here, any number of elements should ideally be able to be created to keep the entire infrastructural language uniform. These constraints, aesthetic proportional systems, and general rules concerning connection methods, will allow for a variety of individual designs, not just for additional elements in a kit-of-parts, but for additional station stops, or even larger buildings and programs.

Shown later will be examples of certain elements that could be implemented based on this set of principles. Infrastructural elements such as posts to hold up overhead powering wires as the trains go farther away from the stations stops will be described. Additive elements such as signaling devices, GPS displays, or route signage can also be incorporated into these posts as well as the previously developed station stops.

Trash and recycling bins, along with chairs and pamphlet holders, will show how catalogued elements can stem from ideas originally developed for the station stops themselves. Larger elements such as potentially required guard or hand rails might also become major elements in the design of these stops once specific sites are chosen. Lastly, elements that might appear as remnants or echoes of this system could be developed. In an urban or campus setting, directionality and way-finding elements that might lead one to a station stop would be desired. A final look at iconographic symbols to represent this system will be explored.

Details and Proportions to Allow for Expanded Design Opportunities

Structural Forces as a Diagram

Earlier designs have already shown how ideas concerning the acting structural forces within these systems have influenced the design of many of these implementations. In general this should be the case for any additional design interventions. The structural condition of a cantilever has influenced many designs as well which has contributed to a certain style of structural members and structural joinery conditions. However as many solutions could be found to resolve a condition of a cantilever, as well as many other structural conditions found within these initial design explorations a set of rules will be established to allow for a specific basis to which one could begin further design studies.

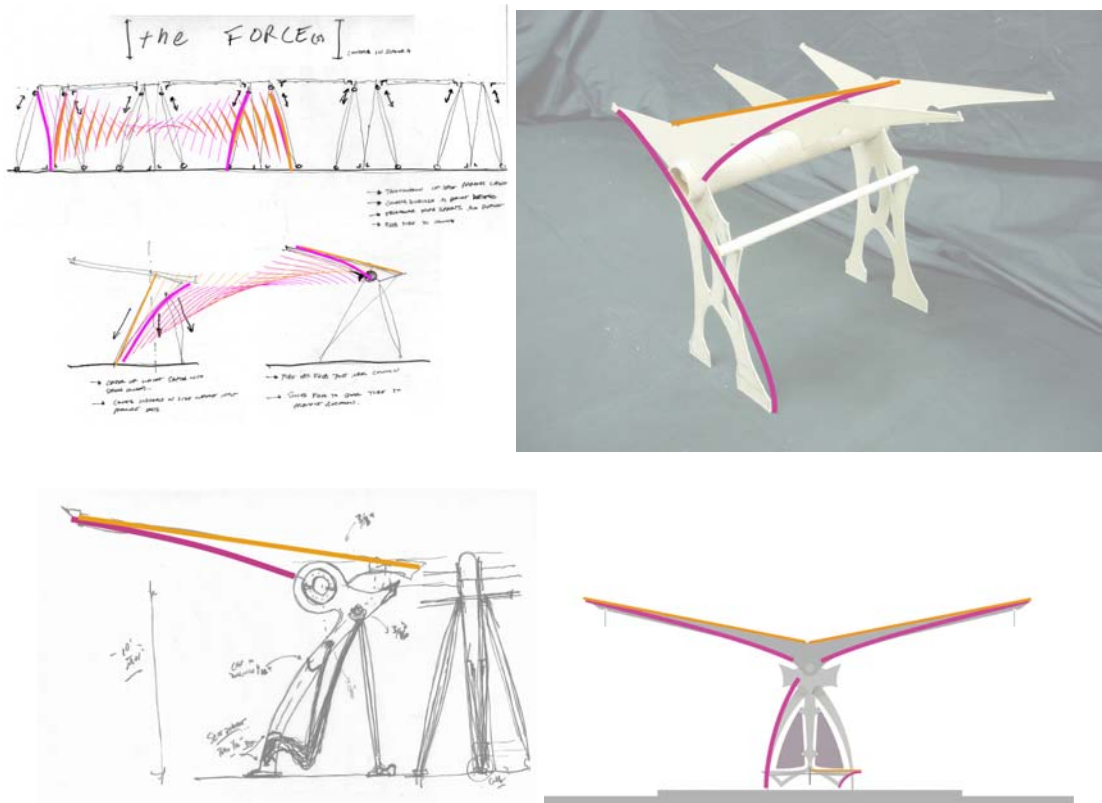

Figure: 7-1 – Continuity of Structural Diagrams.

Rules of Connection

In order to maintain a uniform language for future designs with regard to this infrastructural system, a set of constraints and principles should be established. In general any element that would be in an exterior location should be made of steel and/or polycarbonate materials. This material preference will be the first obvious sign of system coherence. The idea of the slice should be employed throughout as this formal generator drives the design of the major iconic sheltering canopy elements of the system. The later investigations into the remainder of the kit-of-parts will show how this idea can be used in a multitude of situations.

Tubular elements should be used where structural beams will be necessary. This will allow for suggested cantilevering elements to maintain torsional rigidity as well as provide an aesthetic uniformity to spanning elements. Lateral stability in structures should be provided by the columnar assemblies where possible, the one case of the tripod or quadripod shown prior was one solution to this issue. Methods for cross bracing utilizing tension rods or cables should be minimized. Base to ground connections should also be minimized in their intensity. Not necessarily hidden and minimal like the final version of the tripod legs, but celebrated in whatever the specific conditional situation would allow, certainly not an afterthought or simple bolting to a foundation.

Slices, when used, should maintain a few principles. They should be used to support some sort of frame, or secondary element such as seating or roofing. They should not be used as the last piece of structure of a system. If they must be attached to a tubular element as in the case of the station stops or the upcoming hand rails, there should be a similarly flange-bolted condition to surround the tubular element. These will also receive aesthetic guidelines in the next section.

Tubular elements, when connected to columnar assemblies should be bolted in a way to be field assembled and rigidly connected. This will again will encourage torsional rigidity and keep the look of the system uniform throughout.

Lastly when adding elements to infrastructural systems, a conscious effort should be made to design them as if they were grown out of, or could be easily be seen as part of the system. There should be no ad-hoc security cameras simply bolted to the middle of steel roof slice webs for example. As will be described later here, signaling mounts, seating elements, and even light fixtures can be incorporated in such a way as to appear directly a part of the entire system. No element will be simply attached to structures without careful attention to the fasteners used, and the connection method applied.

Aesthetic Proportional Constraints

A few sets of aesthetic proportional guidelines have created the two main elements of this purple line system exploration. The tripod columnar assembly and the roof slice have governed the outcomes of the majority of system elements and implementations. There may be a wide variety of transformations and deviations from these two elements, but the bounding aesthetic principles have carried through to just about every other related item.

For the roof slice, or more generally a cantilevering element, a few basic guidelines should be followed. The thickness of these elements will diminish when approaching the cantilevered end. A curved radius will make up about the first half of this reduction, while a straight but angled line will finish out the slice. The slices overall beginning thickness will be related to the overall spanning distance at about a one to ten ratio. The diagram to follow contains specific proportions related to the roof slice that was implemented in the small single sided station stop, but general bounding

angles and places for curvature will apply to the rest of the roof slices and any element employing this type of language.

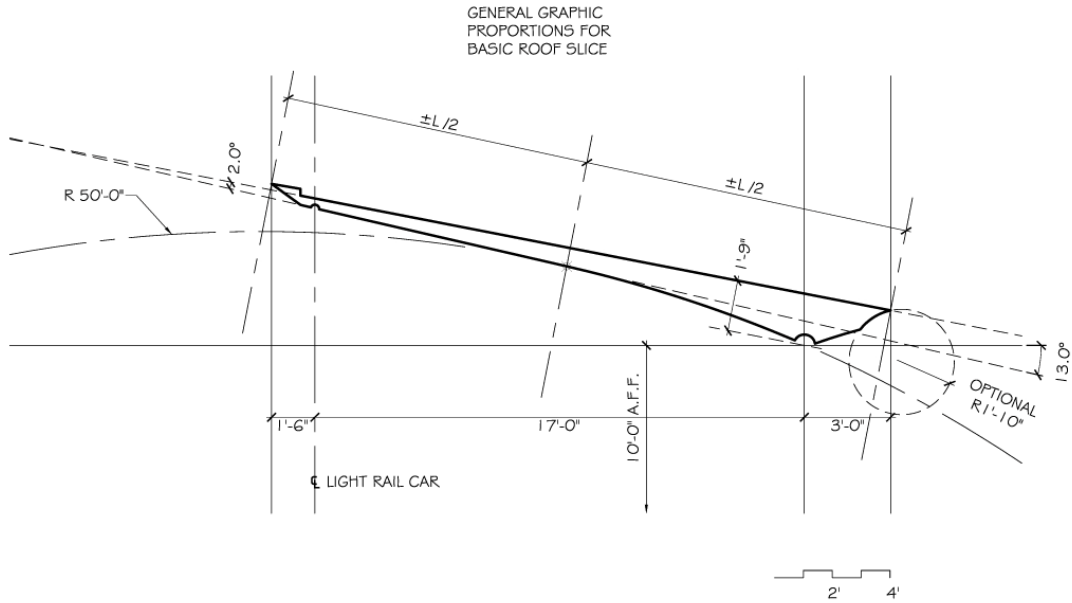

Figure: 7-2 – Aesthetic Constraints for Roof Slices.

For the tripod assembly the height will be about twice the width of the front elevation. The front elevation will be about five sixths the width of the side elevation. In general the structural legs will diminish toward the ground and have varying radii of curvature. Finally the structural offset for the tube steel placement will be about one fifth of the width of the side elevation, directed towards the middle of the structural assembly. The diagram to follow will show the tripod used in the single sided stop configurations and specific related dimensions. These principles however can be applied to other columnar assembly derivations.

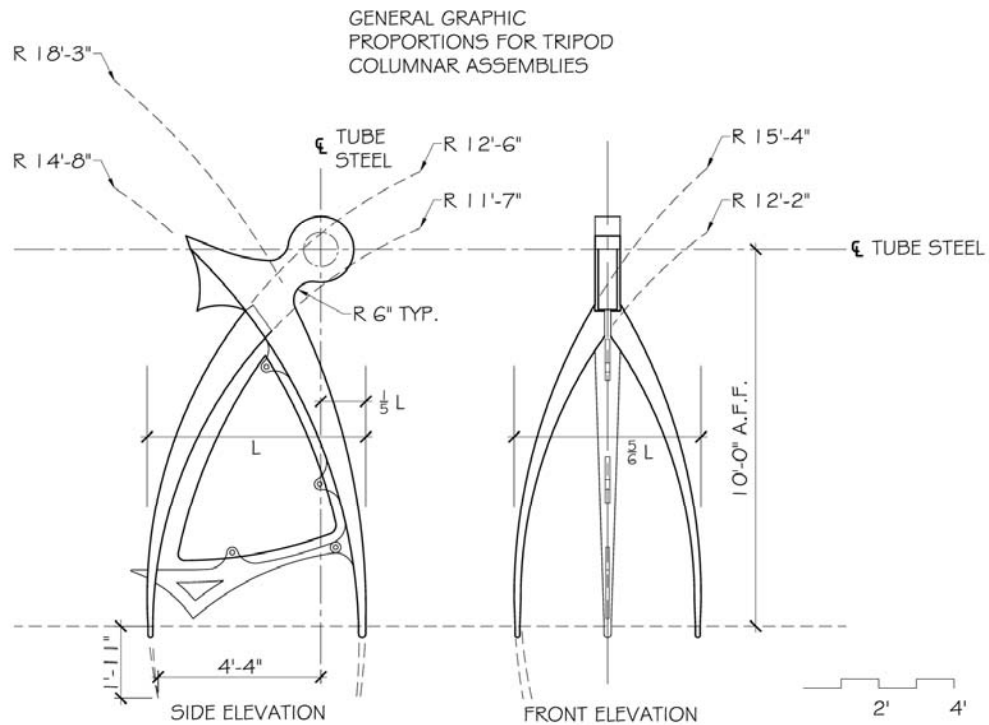

Figure: 7-3 – Aesthetic Constraints for Columnar Assemblies.

Lastly of note, in general these elevation profiles were developed to look sleek, quasi-organic, and light. The consistent ideal showcasing diminishing structure is used throughout. Thin, but technologically advanced structure is celebrated in these interventions. This additional basic principle should readily be applied to any further design interventions attempting to follow this set of guidelines for this infrastructural language.

Wire Support Posts

Reasons for Implementation

The station stops that have been created thus far would ideally do a good job of holding up the overhead powering wires while the trains were under them. However other elements would need to be developed to hold the wires in place along the entirety of the routes. The following interventions would be simplistic elements that would perform this function.

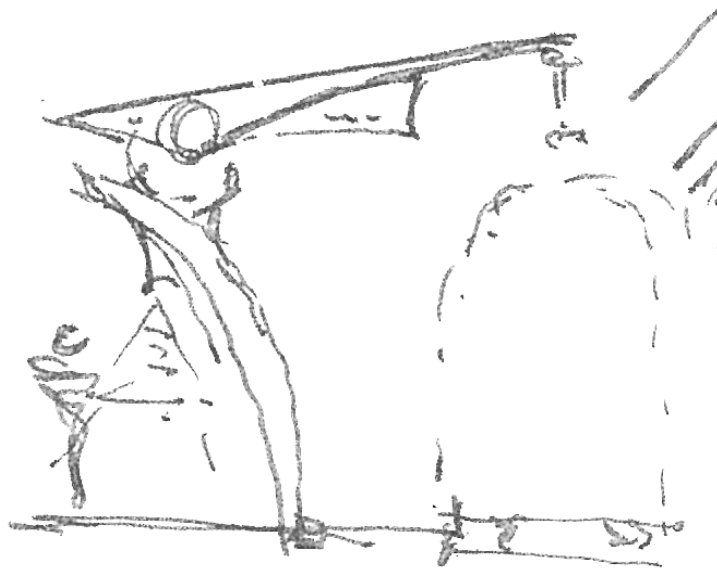

Figure: 7-4 – Wire Support Post Gestural Diagram.

Gestural to Diagrammatic

In a similar situation as the station stops, two versions of these wire-support posts would have to be created, a single-sided version and a double-sided version. These posts would ideally be much more simplistic than the station stop elements due to their frequency throughout and along the intended travel routes. Again, ideas concerning ease in prefabrication, assembly, and simplicity were pursued.

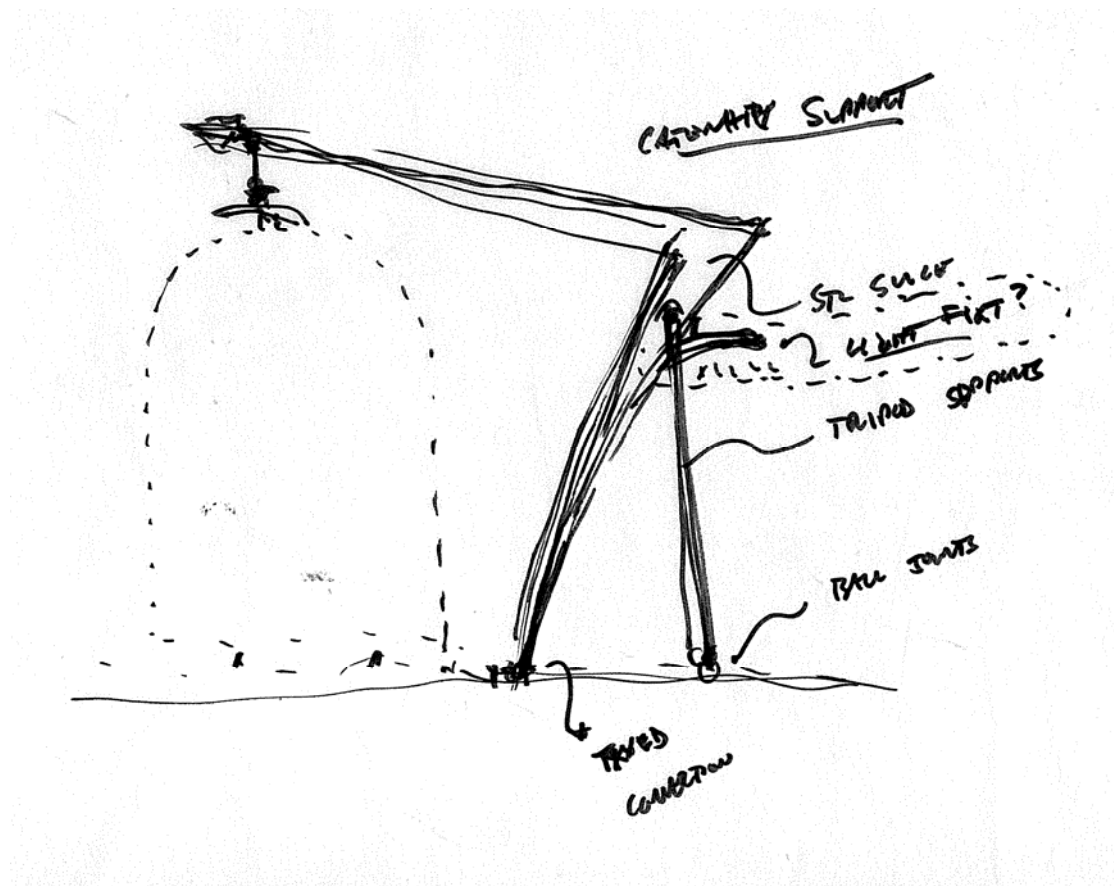

Figure: 7-5 – Wire Support Post Diagram.

A More Accurate Conception

The final version of these two wire-support elements would be made again, sheet cut flat sections of steel. Most connections would be welded, except for a base-to-ground connection which would be bolted to create a rigid connection to mediate between this steel construction and a foundation comprised of reinforced concrete. This post could additionally incorporate additive features of down-lighting in a similar fashion as the station stops, and could also incorporate signaling or signage options as will be detailed later.

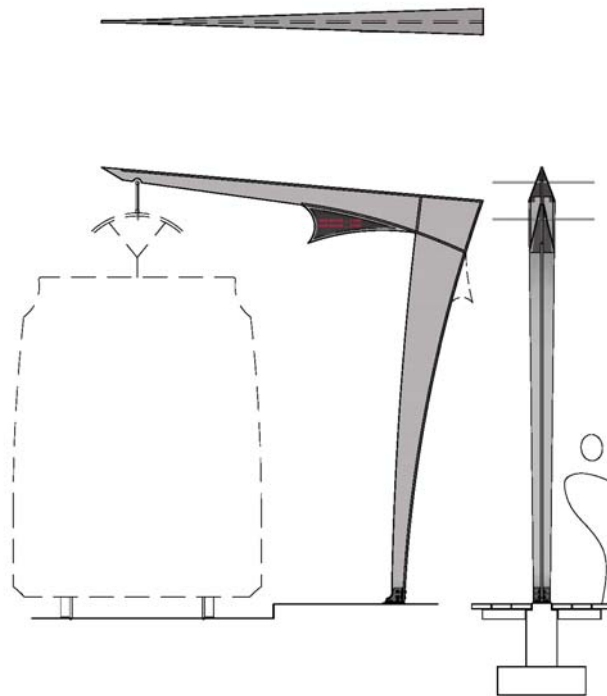

Figure: 7-6 – Wire Support Post Orthographic Representation.

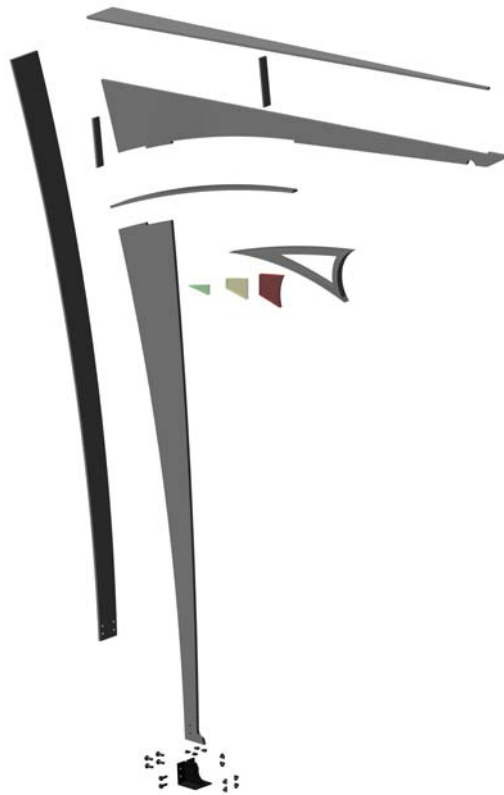

Figure: 7-7 – Wire Support Post Assembly Diagram.

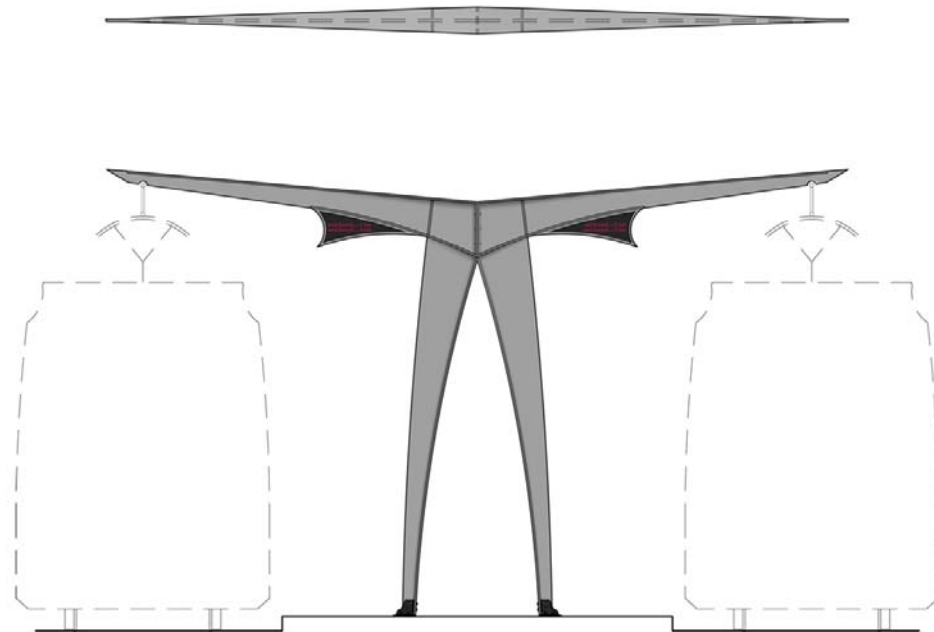

Figure: 7-8 – Double Wire Support Post Orthographic Representation.



Figure: 7-9 – Double Wire Support Post Assembly Diagram.

Signaling Options

Reasons for Implementation

As one traverses along this purple line system, signage elements may be necessary and preferred to provide information concerning everything from GPS train tracking to system-wide notifications. As well, elements that could signal the actual trains would be required for an efficiency of the system. These elements could ideally be incorporated into the station stop designs themselves, or could similarly be included along the previously detailed wire-support posts.

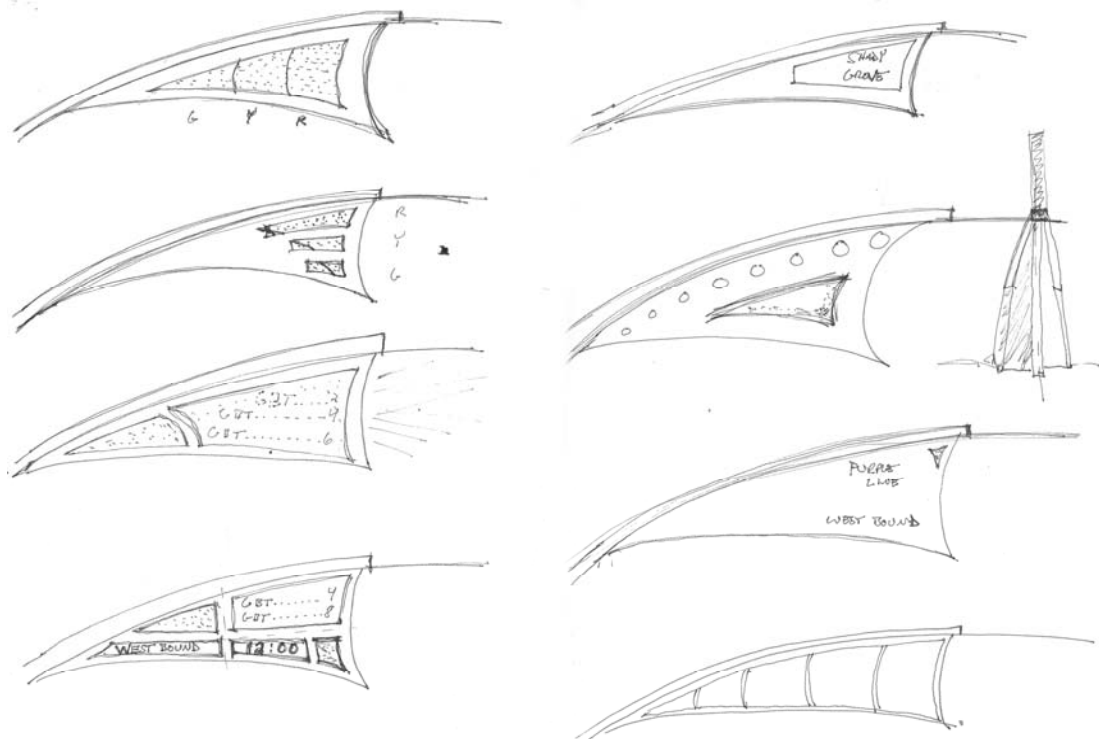

Figure: 7-10 – Conceptual Signaling Option Sketches.

Gestural to Diagrammatic

Depending on the intricacy of the function of these actual display items, multiple functions could be incorporated into each additive piece of this type of signage.

Ideally based in the same attachment methods, that being under-mounted from a roof slice whether as part of a wire-support post element or under a station stop canopy, this similar frame could be used to house a variety of functions. As long as the shape stayed the same, this region would become a uniform element across the system for one to find information. Again power concerns for this type of signage might arise, but systems of self powered solar collection systems could run wires from a canopy roof, or along the spines of the wire support posts and there could be through-flange holes to run conduit into these elements.

A More Accurate Conception

The end result of these signage frames yielded a few options that would vary depending on location and function. One option would be a simple LED stop/slow/go signal used for the trains, while another would be a simple metal frame used for route identification signage. Other LED display screen elements, similar to the ones used in the D.C. Metro today, would display active train tracking and route alerts. Lastly, combinations of these elements could be included into these signage frames but a more simple approach would probably be preferred with this element.

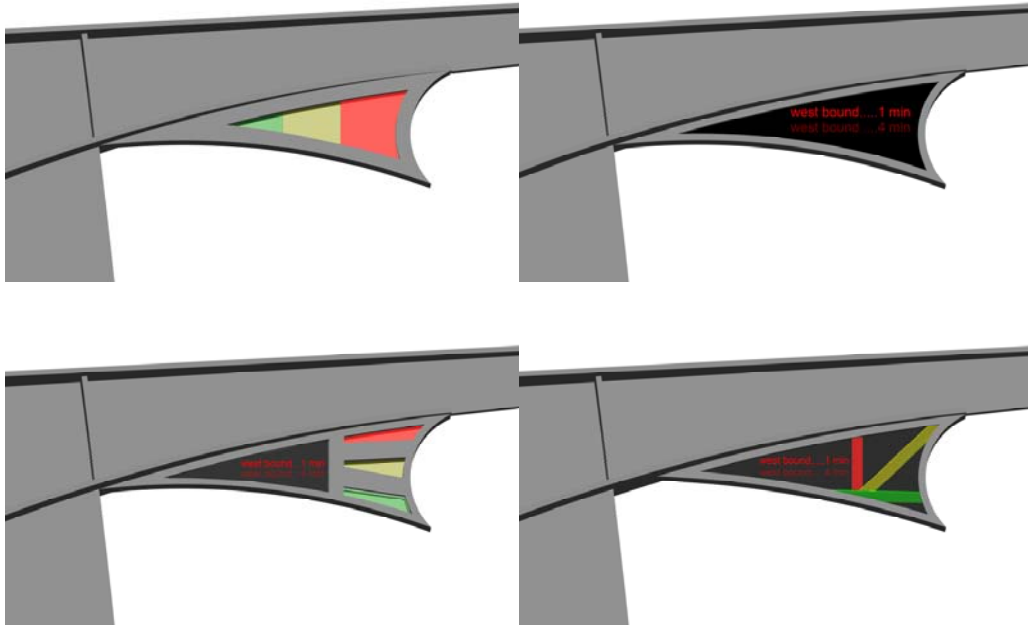

Figure: 7-11 – Signaling Option Examples.

Trash or Recycle Bin

Reasons for Implementation

As people travel on public transportation food will be consumed and trash will be produced. A receptacle for this activity is always preferred. However many times these elements for trash collection are very additive and simply placed in the middle of hallways or otherwise not thought of in a designed fashion. Trash and recycle collection should be an early thought of inclusion for any public building, but especially a public means of transportation. Bins that could be integrated in a thoughtful fashion would be desired and the means to do just this will be explored.

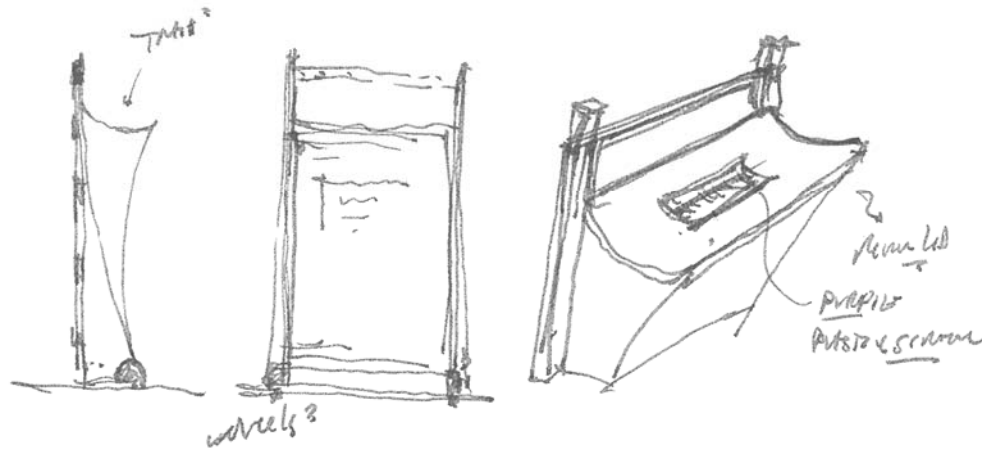

Figure: 7-12 – Trash Bin Conceptual Sketches.

Gestural to Diagrammatic

A type of bin that could either interlock with station stop structural bay spacing or tuck beneath certain station stop elements might be a starting point to see how these two systems could mesh. As well, because collection bins are usually controlled by a proprietary organization, they would need to be easily accessible and able to be interchanged and emptied quickly. A multiple-part bin that could appear in the same language as the rest of these purple line implements would be ideal. By including a bin frame on wheels and inserting bins into this frame, one could easily access the bins if needed, but the frame could be produced in such a way to maintain its position if interlocked into a station stop rear wall for example.

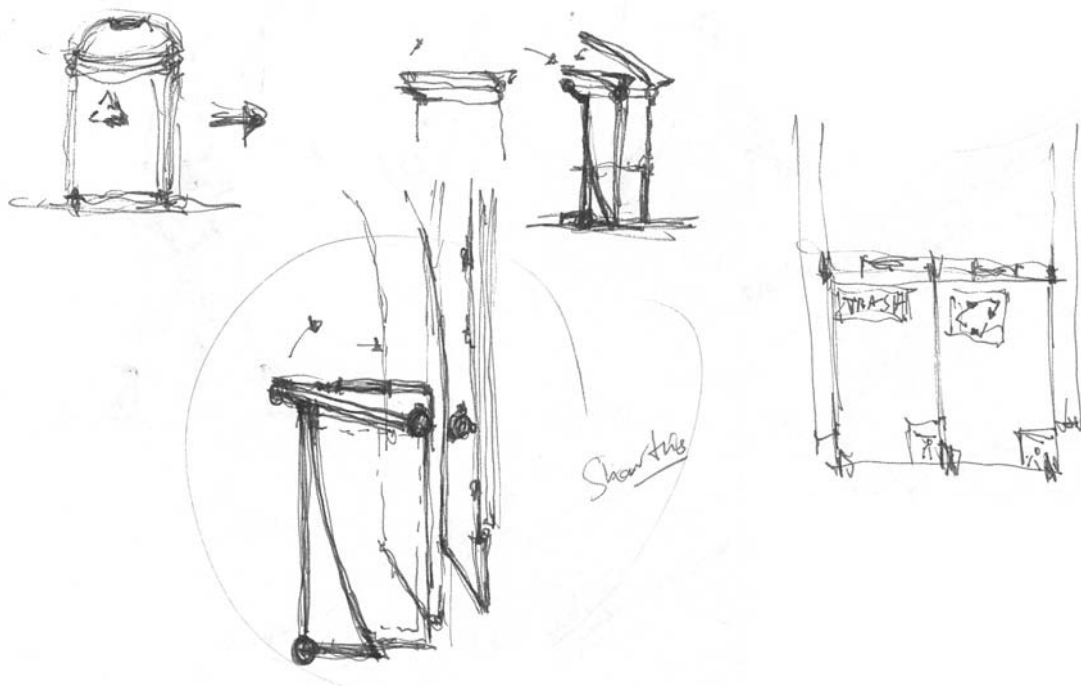

Figure: 7-13 – Trash Bin Diagrammatic Sketches.

A More Accurate Conception

The final version of these collection bins would be introduced for the single-sided stop configuration. Two of these bins would fit between the structural spacing of two roof slices and could interlock to each other and the slices themselves. As well, the side profile of these bin frames would be such as to sleekly fit tucked under the typical roof slices.

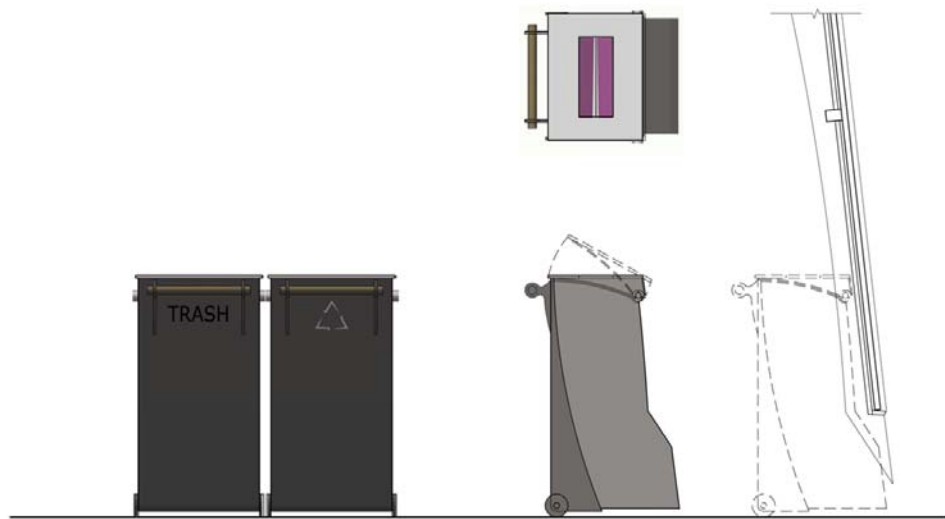

Figure: 7-14 – Trash Bin Orthographic Representation.

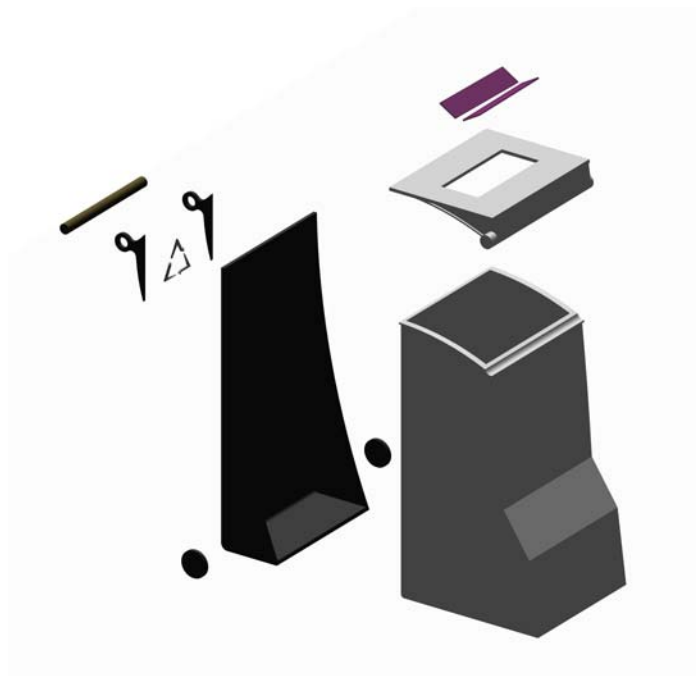

Figure: 7-15 – Trash Bin Assembly Diagram.



Figure: 7-16 – Trash Bins Realized View.

All-Weather Chair

Reasons for Implementation

In cases where additive seating would be required a seat that embodied the language and ideals about this new age-system would be preferred. A chair that could employ the same materials that were used throughout the system would provide obvious cues to its origins and technological era.

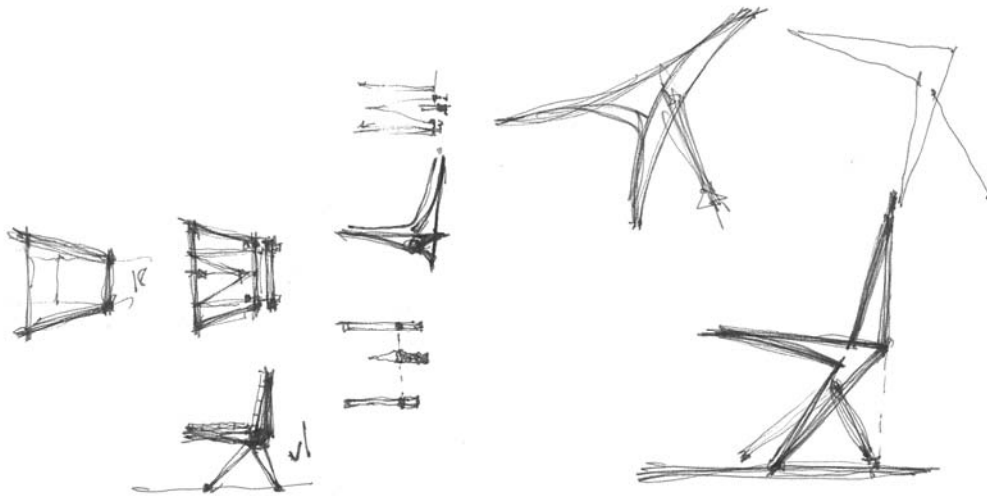

Figure: 7-17 – Chair Conceptual Sketches.

Gestural to Diagrammatic

Approaches were made to create a chair that embodied the same language as the station stops where tripod supports would hold up a tubular element which would then support the roof surface, in this case the seating surface. However this proved to be a little over the top in the end and a more simplified approach was explored.

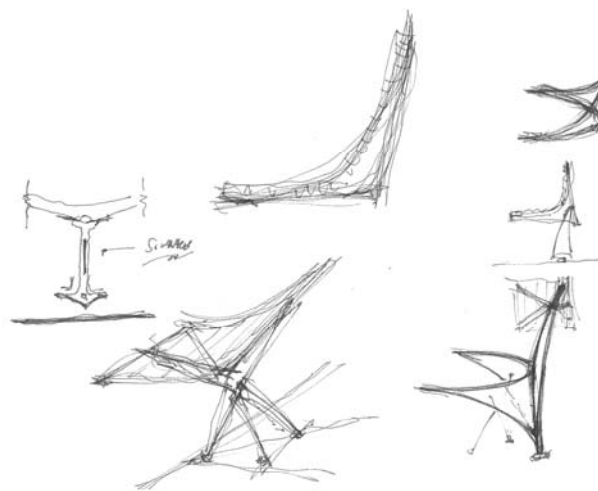

Figure: 7-18 – Chair Diagrammatic Sketches.

A More Accurate Conception

The final chair would employ the idea of the slice being attached to a tubular element in a rigid fashion. These slices would simultaneously be supports for the seating surface, and columnar elements becoming the legs for the chair. By interlocking these about a notched tube, when one would sit on the chair, opposing forces would strengthen the connections between the slices. Lastly a material that would appear mesh-like or grid-like in a similar fashion to the structure of the polycarbonate roof material being installed in the station stops, could add to the similarities across the system. This material could be attached with 'u-bolts' to the metal chair slices. If the material was actually porous, or simply as weather-proof as polycarbonate, this chair could be used in a variety of indoor or outdoor conditions. Finally this chair could also be expanded due to its modular nature simply by adding more slices to a longer notched tubular element and producing a larger seating surface.



Figure: 7-19 – Chair Orthographic Representation.



Figure: 7-20 – Chair Assembly Diagram.



Figure: 7-21 – Chair Realized View.



Figure: 7-22 – Chair Modular Options View.

Pamphlet Holder



Figure: 7-23 – Pamphlet Holder Conceptual Sketch.

Reasons for Implementation

A device that could show the same type of connection and detail as the entire infrastructural system that could be used to hold information concerning the infrastructural system would be ideal. Current holders for newspapers and pamphlets are very generic and are usually added wherever there is room in a fashion that could be considered less than designed. A new type of device that would stand out in a field of oppressive distribution boxes could reinforce how this system as a whole interfaces with current architectural implements.

Gestural to Diagrammatic

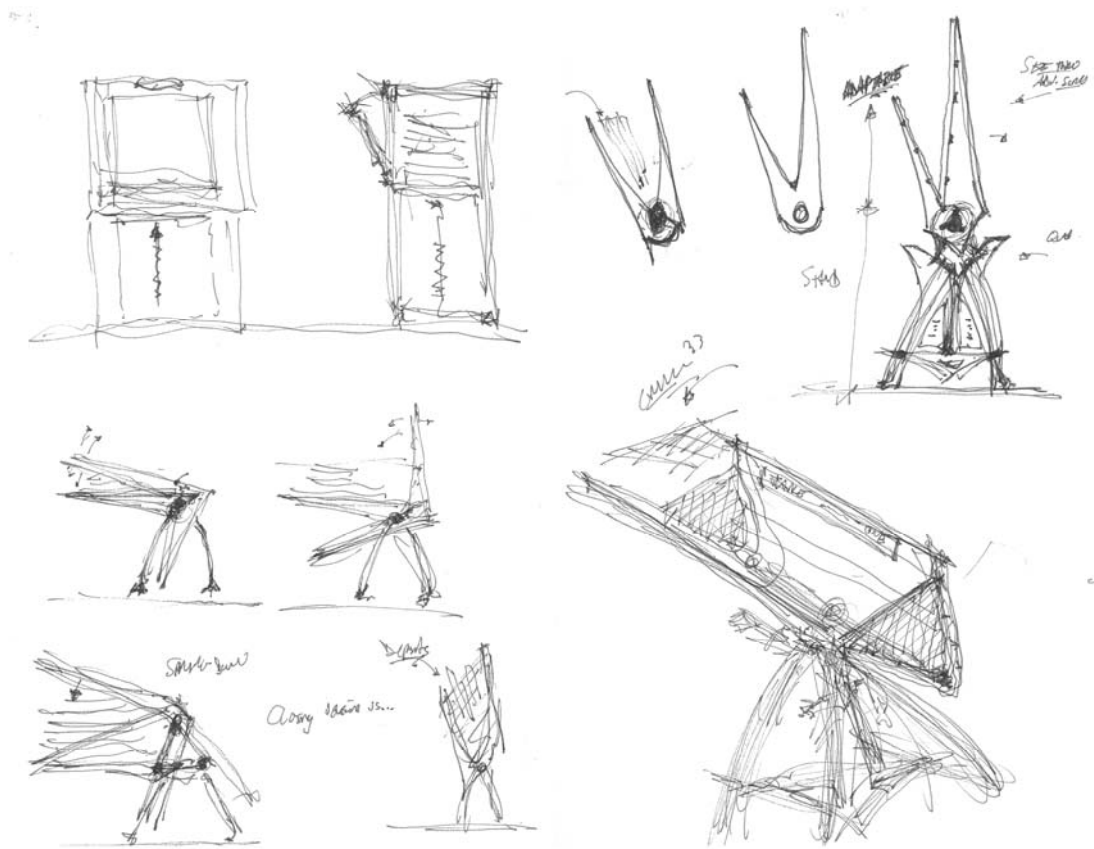

Figure: 7-24 – Pamphlet Holder Developmental Sketches.

Again a desired design intent to maintain an attitude about connection types throughout the system led to designs beginning with tripod and quadripod stands that would lightly make contact with the ground. Additionally tubular elements would then be attached to those stands to support an above holder made from the same frame of steel, or in this case other light-weight metal, and finally polycarbonate enclosing materials.

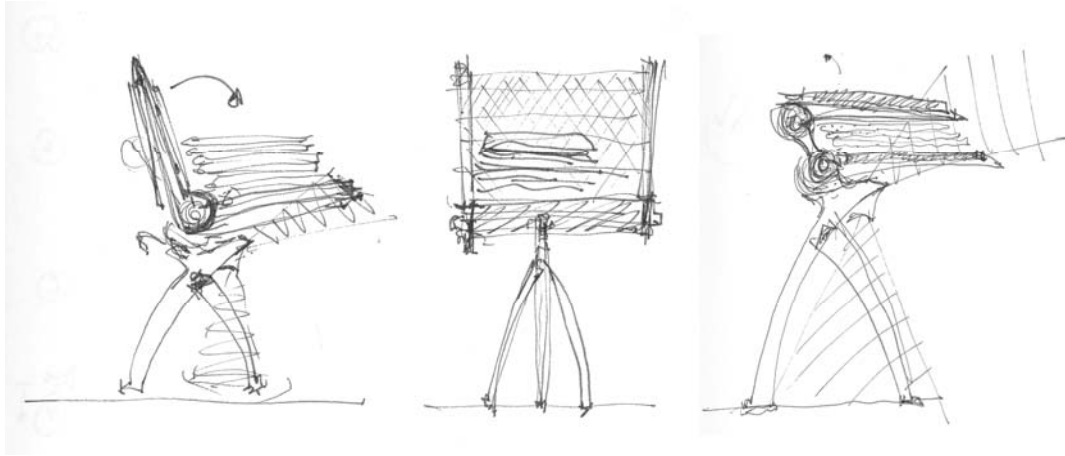

Figure: 7-25 – Pamphlet Holder Diagrammatic Sketches.

A More Accurate Conception

A final version developed a scaled down, and simplified version of the quadripod used in the invention of the double-sided station stop. This stand could feasibly be secured in a similar fashion as the station stops, but either way, giving the appearance of a light structure that is sleek and unique among other holders nearby. A similar notched tube as used in the above chair exploration could then secure a holder composed of metal slices and clipped on framed polycarbonate. Some sort of spring-loaded closing element would then complete the holder to keep advertised information from blowing away in the wind.

Ideally, other pamphlet holders would have been developed to become more integral in the station stops themselves. But in keeping with current trends and attitudes revolving around this type of design and implementation, this holder would stand out and once again become an echo of this new public transportation system wherever it might be located.

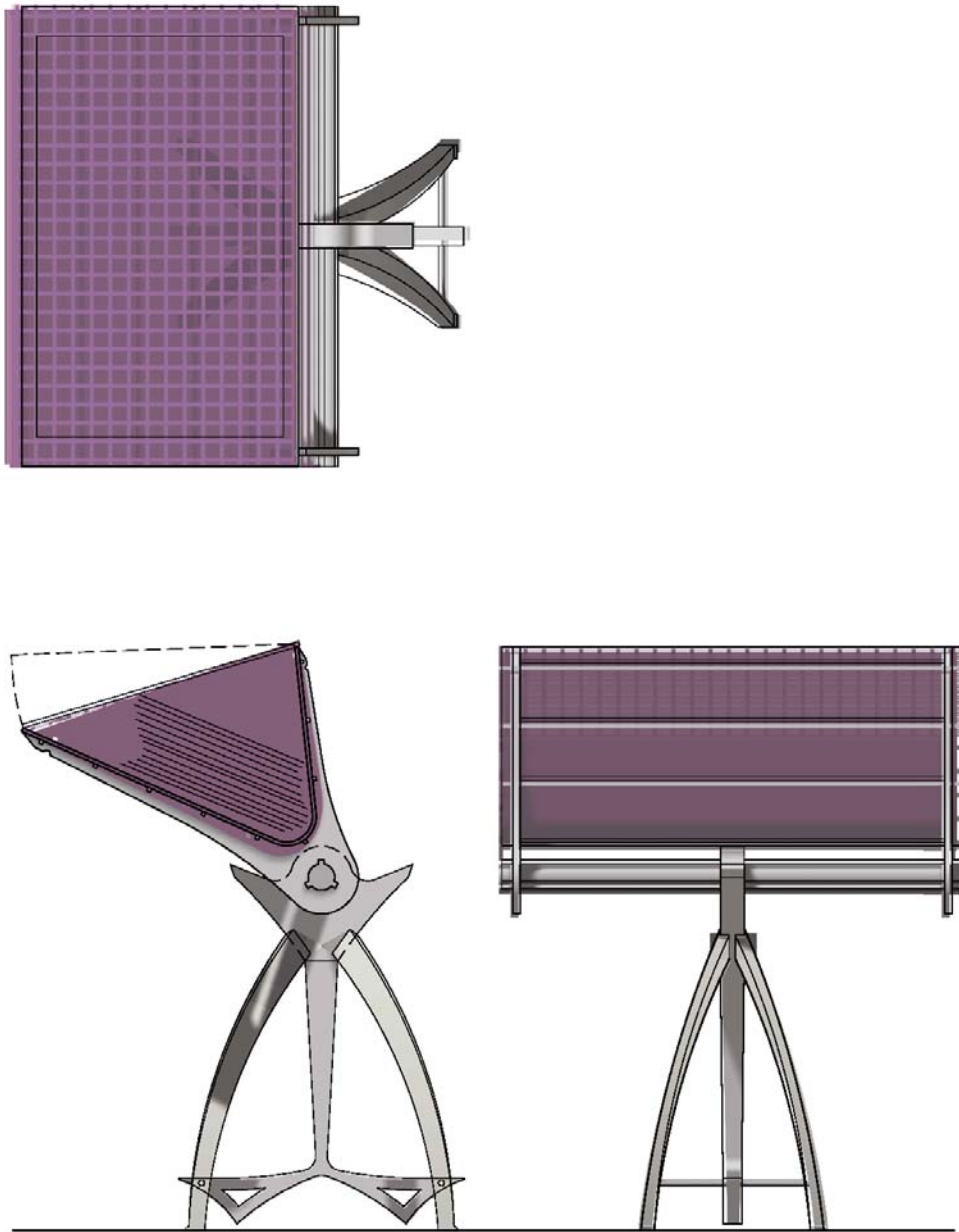

Figure: 7-26 – Pamphlet Holder Orthographic Representation.

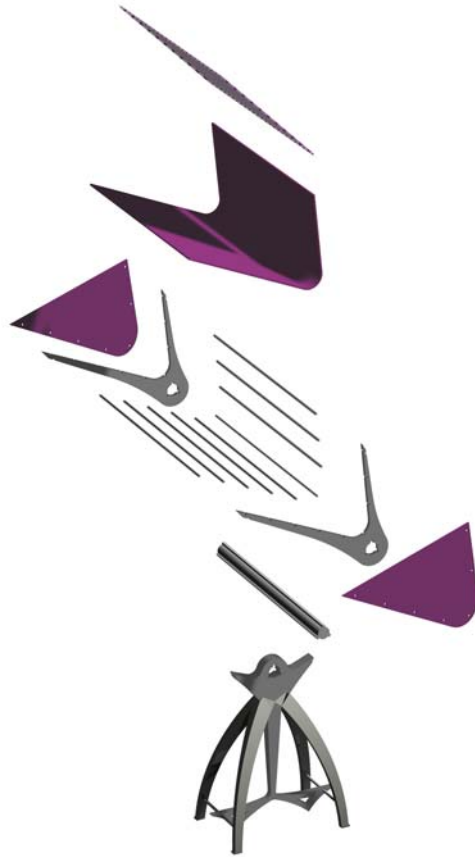

Figure: 7-27 – Pamphlet Holder Assembly Diagram.



Figure: 7-28 – Pamphlet Holder Realized View.

Hand and Guard Rails

Reasons for Implementation

At some locations within this proposed infrastructural system, protection from grade changes would be necessary. Whether alongside a ramp or set of stairs, platform edges, or rooftop balconies, railings would need to be provided. Depending on the exact situational use the rails could take different approaches to their design.

However, in order to maintain coherency to the infrastructural system, the design guidelines for aesthetic appearance and rules regarding methods of connection should still be employed.

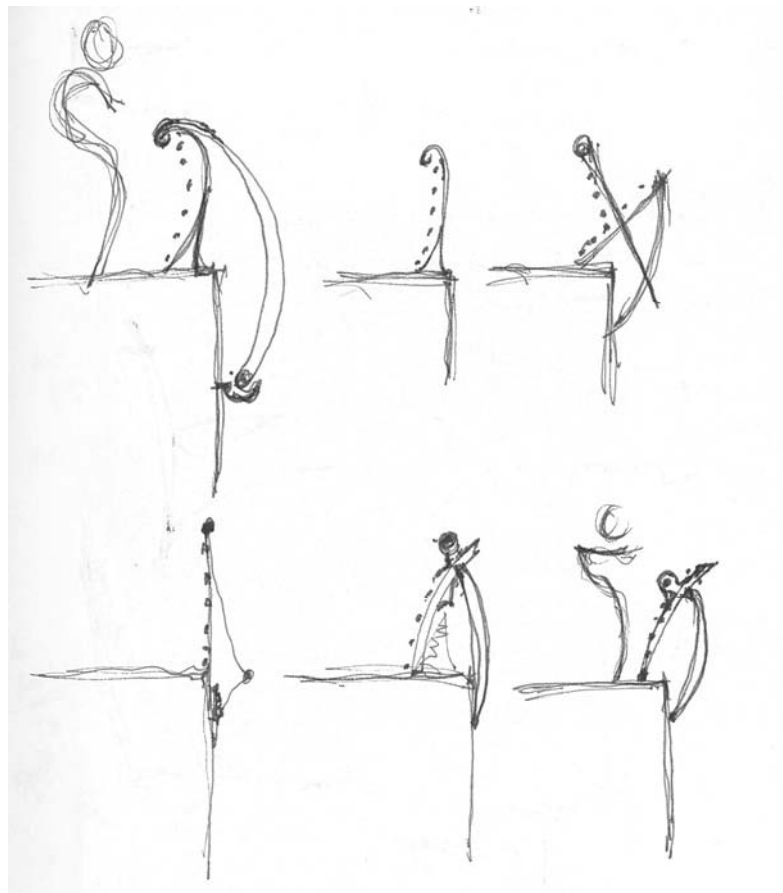

Figure: 7-29 – Railing Conceptual Sketches.

Gestural to Diagrammatic

Two railings would be developed based on two general situational conditions. One where a protective element might simply be placed alongside a subtle grade change or ramping condition, and the other would take an approach to keep users farther away from a more drastic edge condition. Both sets of railings could incorporate elements to light a path, but in general, be efficient yet exciting transformations of the purple line language.



Figure: 7-30 – Railing Diagrammatic Sketches.

A More Accurate Conception

Final version one would take the approach that a roof structure or surface would become the protective element to mediate between edge conditions. This roof structure, whether the case of purlins in the station stops, or polycarbonate panels seen in many other purple line interventions, this surface would become the protective element. However in order to support the roof structure, roof slices would have to be employed, in this case connected to the ground by a new type of bolted condition. Those roof slices could then be joined by a tubular element which would

become the handrail itself. This hand rail would be attached to the slices by bolted flange assemblies similar to the station stop construction, and could have integral LED strips inside of the rail to down-light an adjoining pathway.

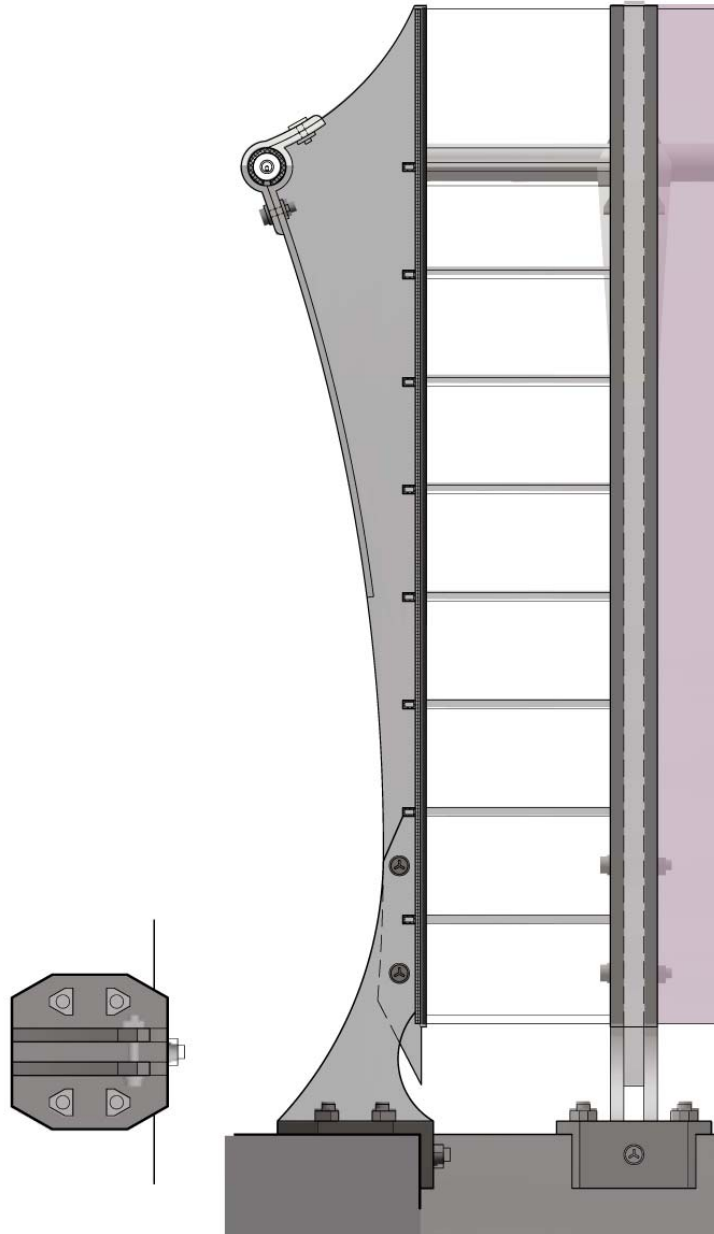

Figure: 7-31 – Railing One Orthographic Representation.

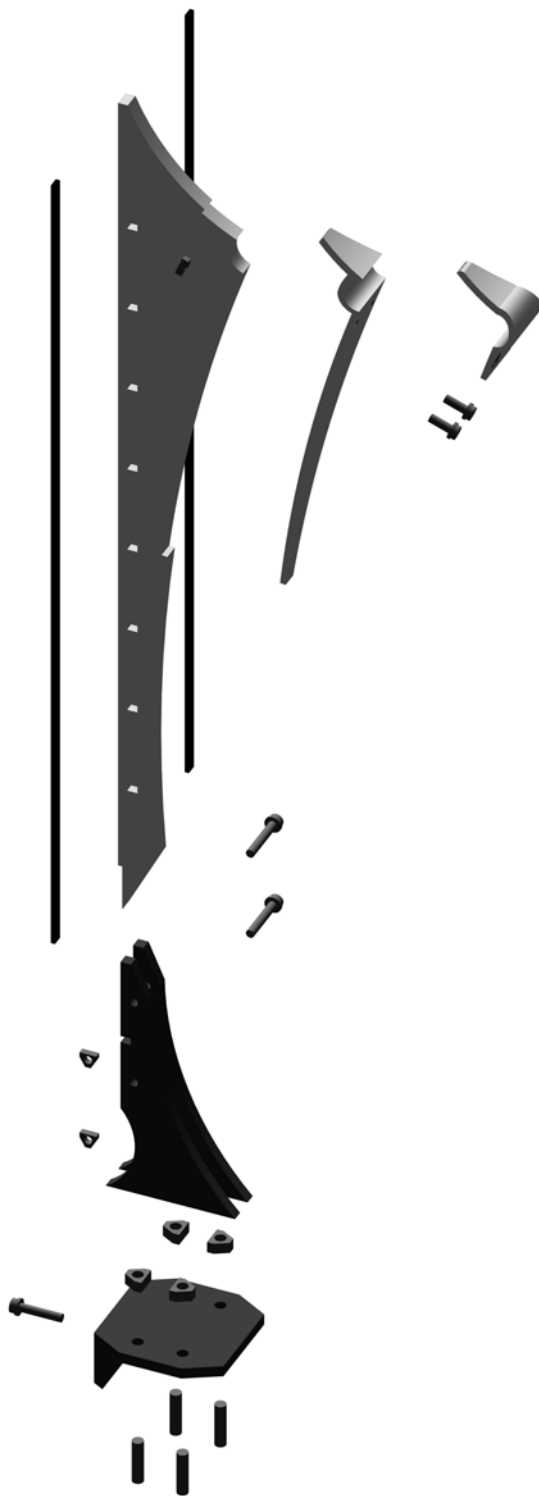

Figure: 7-32 – Railing One Assembly Diagram.

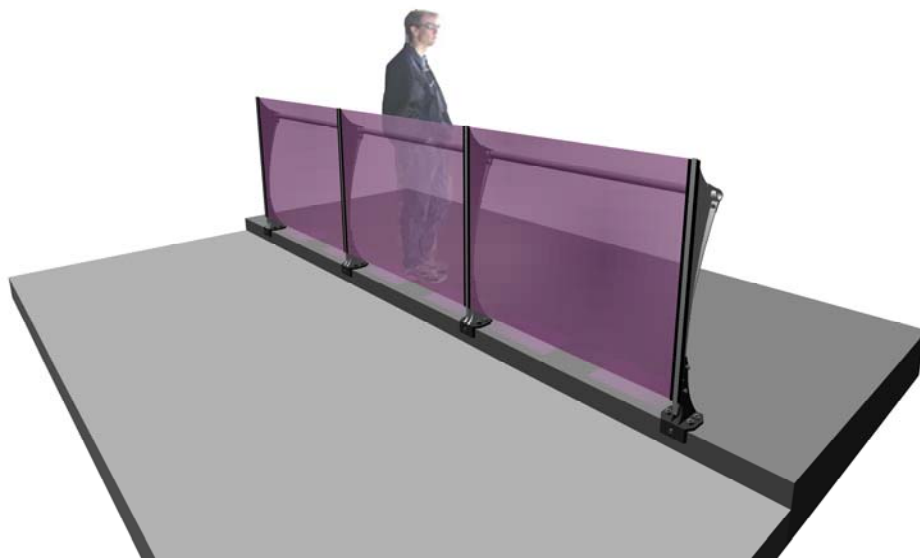

Figure: 7-33 – Railing One Realized Views.

Final version two would employ a rigidly tubular member, similar in style to the tripod's main columnar element. This leaning column in this case could be rigidly attached to the ground to remove the need for supporting tripod legs and to clear up

space for pedestrian travel. This leaning feature would additionally keep pedestrians farther away from an edge where greater grade change might be occurring. Again, a tubular element would be attached to this columnar assembly with rigidly through-bolted flanges and this element would again become the hand rail. In this case, the columnar assembly could support light fixtures in a similar location as on the tripods, and on top other functions such as an ash tray could be included.



Figure: 7-34 – Railing Two Orthographic Representation.

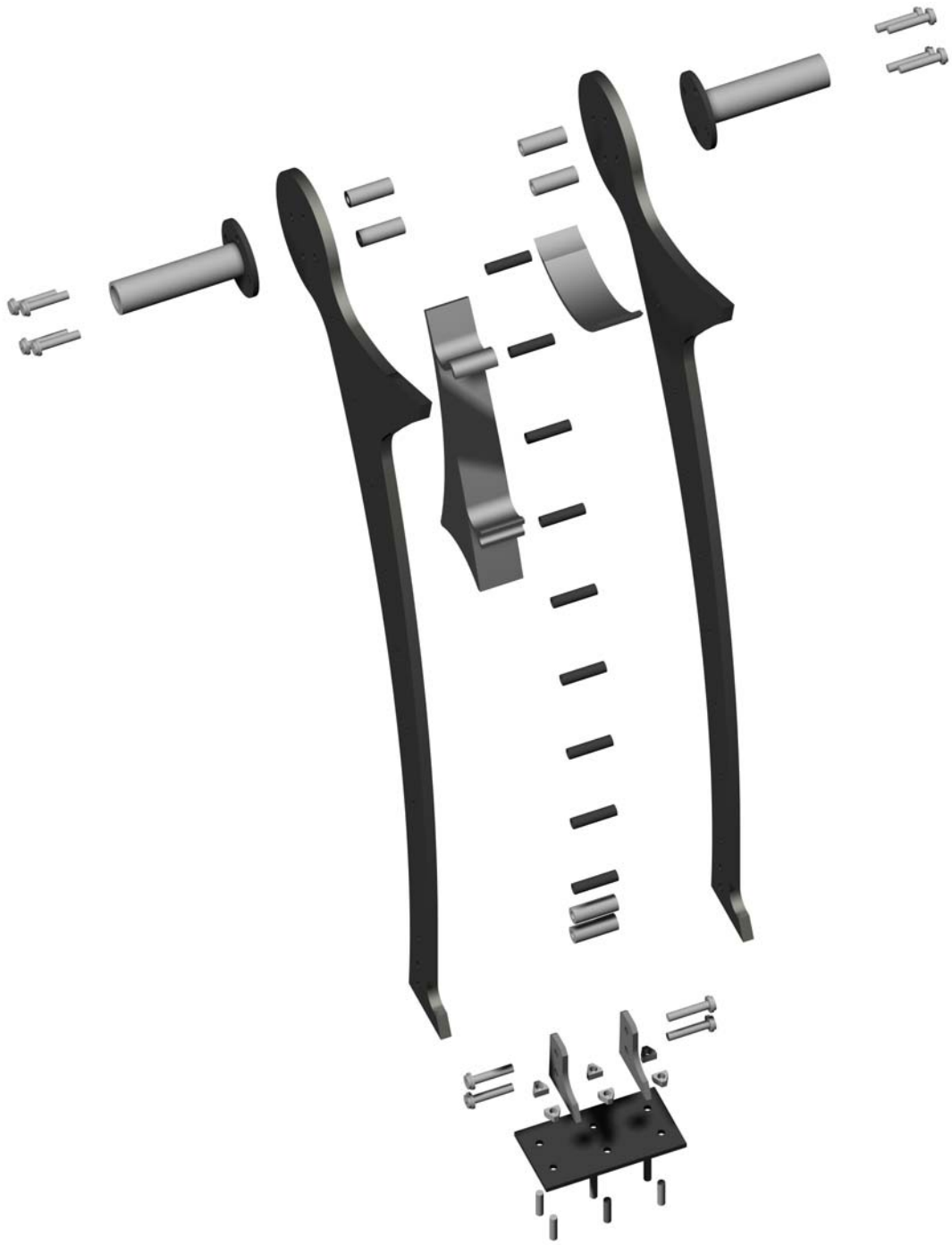

Figure: 7-35 – Railing Two Assembly Diagram.



Figure: 7-36 – Railing Two Realized View.

Way-finding Post and Clock

Reasons for Implementation

Once the station stops and routes have been established people will need to know how to travel to them. Issues of way-finding will arise very quickly as these station stops might lay in semi-hidden locations. If elements could be created that resembled the language and design of the major element in the system, obvious connections could be made by travelers seeking directionality in a world with an ever confusing bombardment of signage and advertising.

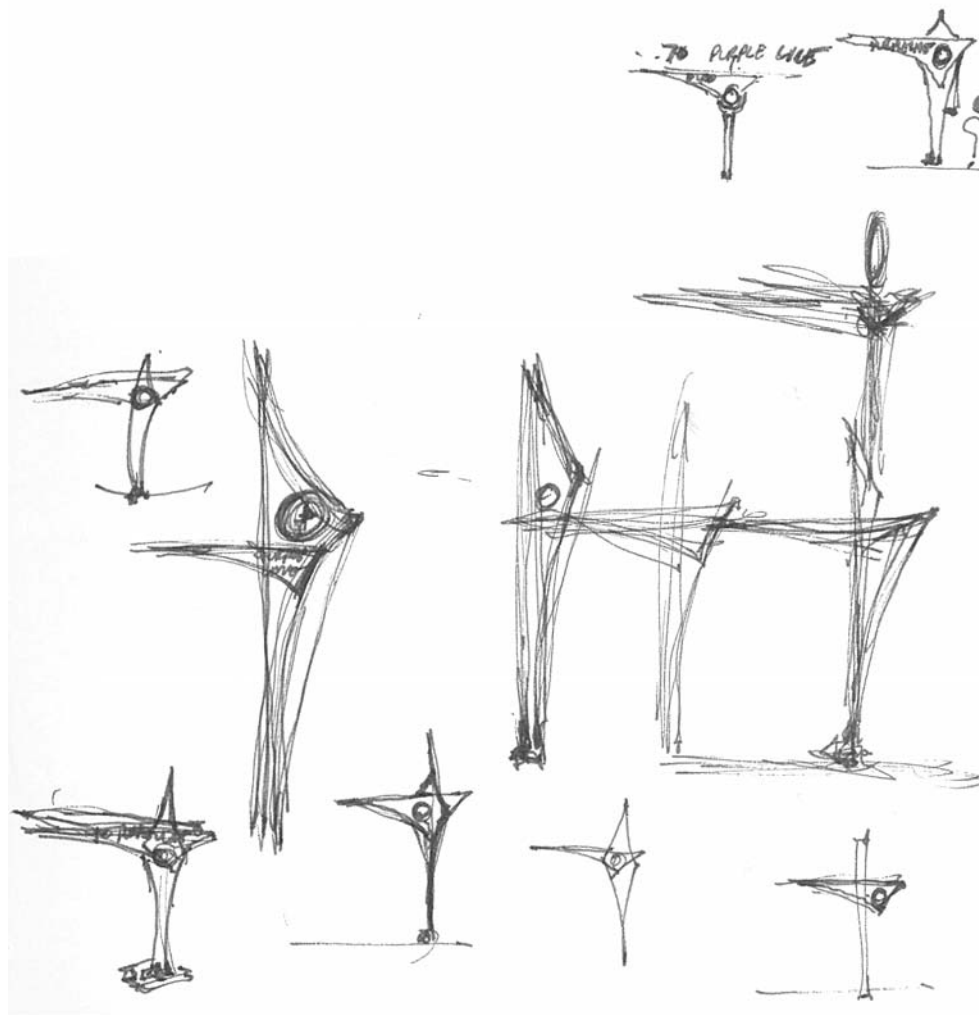

Figure: 7-37 – Way-finding Post Conceptual Sketches.

Gestural to Diagrammatic

In thinking about way-finding, many ideas originally arose. However in the end it seemed that a simple post containing places for signage, seating, lighting, and time display would become a very effective means of directing travelers to station stops and other system nodes. Development of a structurally efficient, stand-alone fashion to accomplish this feat would follow.

A More Accurate Conception

The final version of this post ideally would be oriented to point and face toward the nearest station stop or other purple line system node. The slice language would reappear and become the directional element in this post. The main post would be assembled in the same fashion as the other columnar elements in the system as a set of sheet cut sections welded into a tubular structure. This then could hold power supply lines to power a system-inspired time piece, and integrated columnar down-lighting elements. Seating could be added to this post with the same type of notched tube which would run through the column near its base and be attached to slices the same way as the previous chair had been assembled. These slices would then support the same type of naturalistic seating surface as used in the station stops themselves.

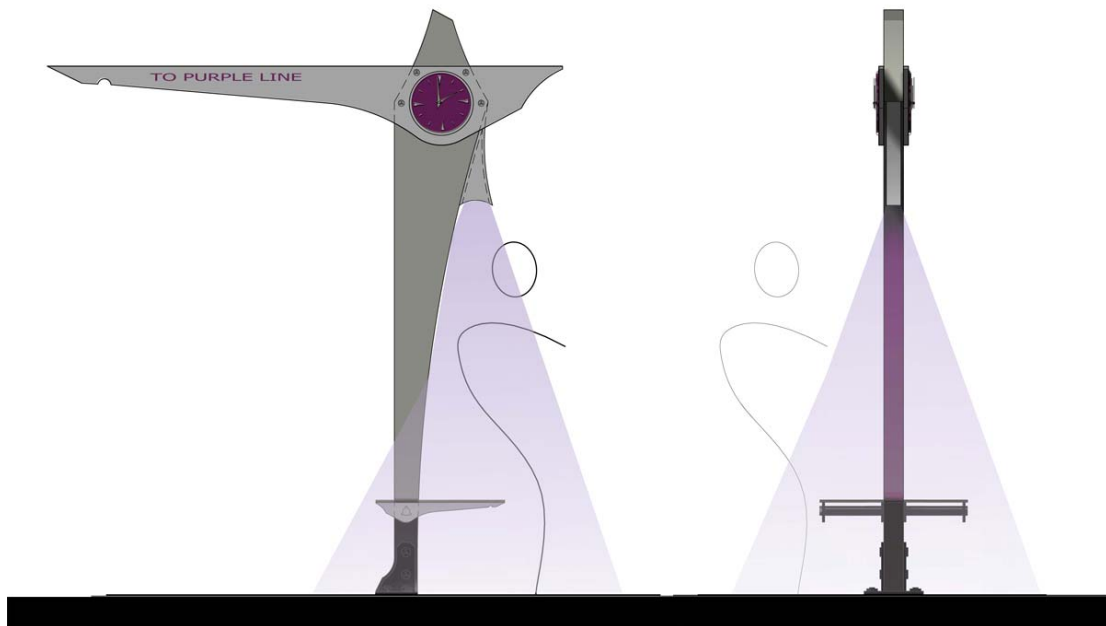

Figure: 7-38 – Way-finding Post Orthographic Representation.

This way-finding post might be a familiar element and the first one travelers encounter on their way between differing modes of public transportation. For example, these could be near the University of Maryland Campus Drive location if the purple line route does not end up traversing this main avenue through campus. This area currently being a major node of city and campus bus traffic would be the perfect location for a directional element towards another on-campus transit station. This then would assume the purple line might occupy the Preinkert Hall Stop location instead.



Figure: 7-39 – Way-finding Post Realized View.

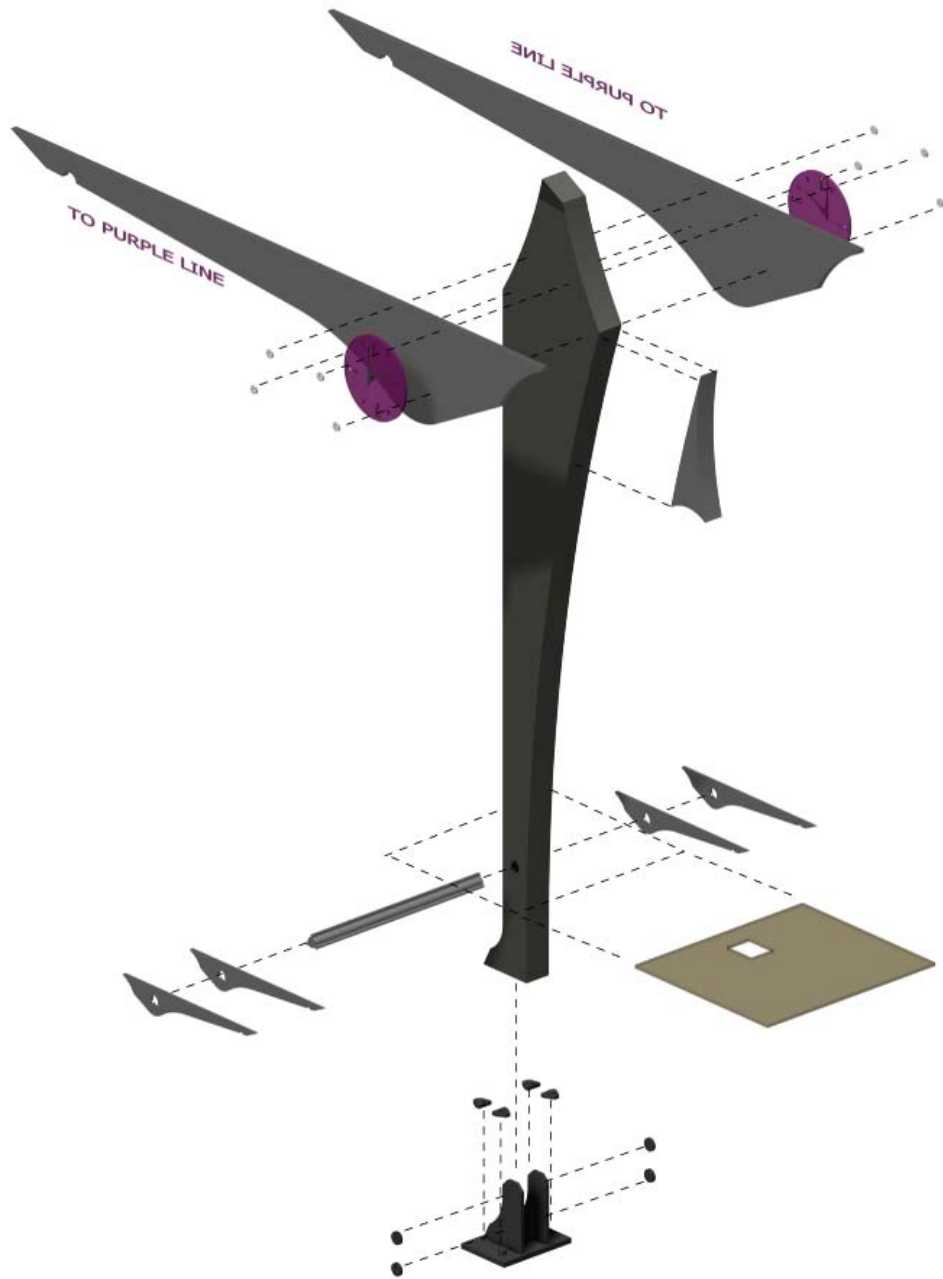

Figure: 7-40 – Way-finding Post Assembly Diagram.

Symbols and Iconography

Reasons for Implementation

To advertise for, and to provide a system of additional directionality and uniformity after the completion of this infrastructure, symbols and graphics should be produced. Every system of transportation nowadays has its own graphic identifier. What better means to identify a cutting edge system than by including cutting edge abstract representational graphics? These graphics could be placed on pamphlets, signage, or any other device that might be used to represent the purple line. Other elements besides graphical abstractions could be used to symbolize this route, such as the development of a new system of fasteners that could be used throughout the system implementations.

Gestural to Diagrammatic

Again developments were made to come to a level of abstraction in signage that could be used to represent this system. Again, the basic structural diagrammatic ideas proved to provide beginning inspiration for the appearance of these graphics. Iterations were later made to incorporate such information as potential stop location signage, and directional arrows.

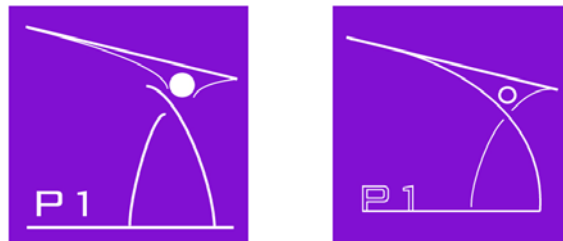

Figure: 7-41 – Way-finding Symbol Process.

A More Accurate Conception

The final version is an abstraction of the single sided small station stop. This graphic abstracts the lightness of the structural elements with graphically sleek and diminishing line weights. As well, the roof slice abstraction could become the directional element but additional arrows and route information could be added along the bottom of this type of signage.



Figure: 7-42 – Way-finding Symbol.

Lastly a system of fasteners has been used throughout the final version of this kit-of-parts as well as the station stops. New bolt heads were developed to evoke the tripod nature of the majority of the stops. Instead of a traditional 4-pronged Phillips head style screw, a 3-pronged approach was taken. Additionally, a normal hexagonal

ratchet head would not work for convenient disassembly of these pieces, but a more triangulated irregular hexagonal shape would be used for the nuts of this system. Most of the diagrams the detail of the bolt heads cannot be seen but this gestural diagram shows the basic principle of this detail.

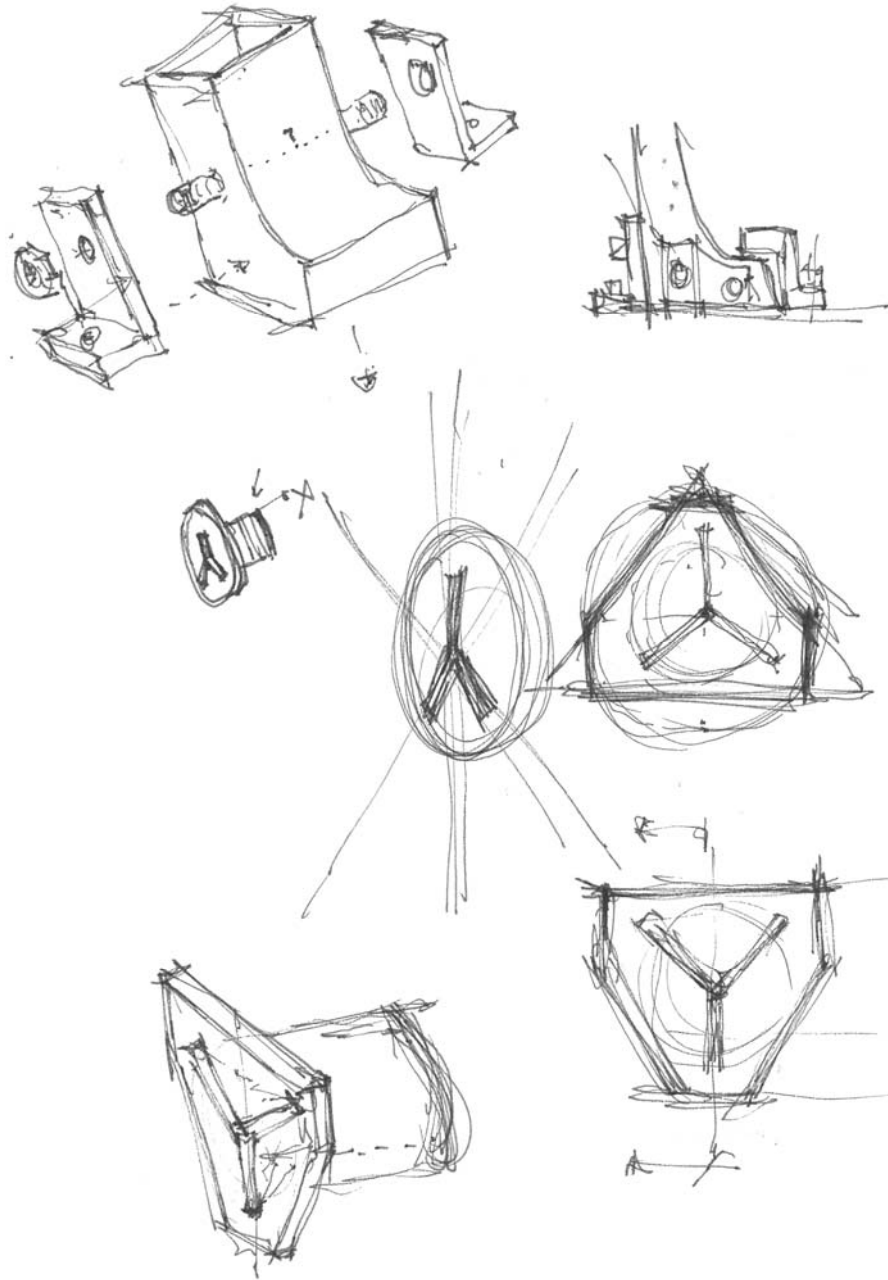

Figure: 7-43 – Unique Fastener Diagrammatic Sketches.

Additional Propositions

Conceptual Beginnings Not Developed to Realization

In the end, many other detail explorations were begun, but not completed to a level of realization as the remainder of this kit-of-parts. One such example took the stance that the cheapest solution to the problem of a need for shelter should be explored and related to this infrastructural language. This stop would be more in scale with the typical bus stops that plague our streets today. Ideally this shelter would be a materially efficient piece of street furniture that could utilize the majority of the sheltering surfaces as places for advertising. A simplistic approach to assembly would be exhibited while still following the rules for connections and aesthetics listed at the beginning of this chapter.

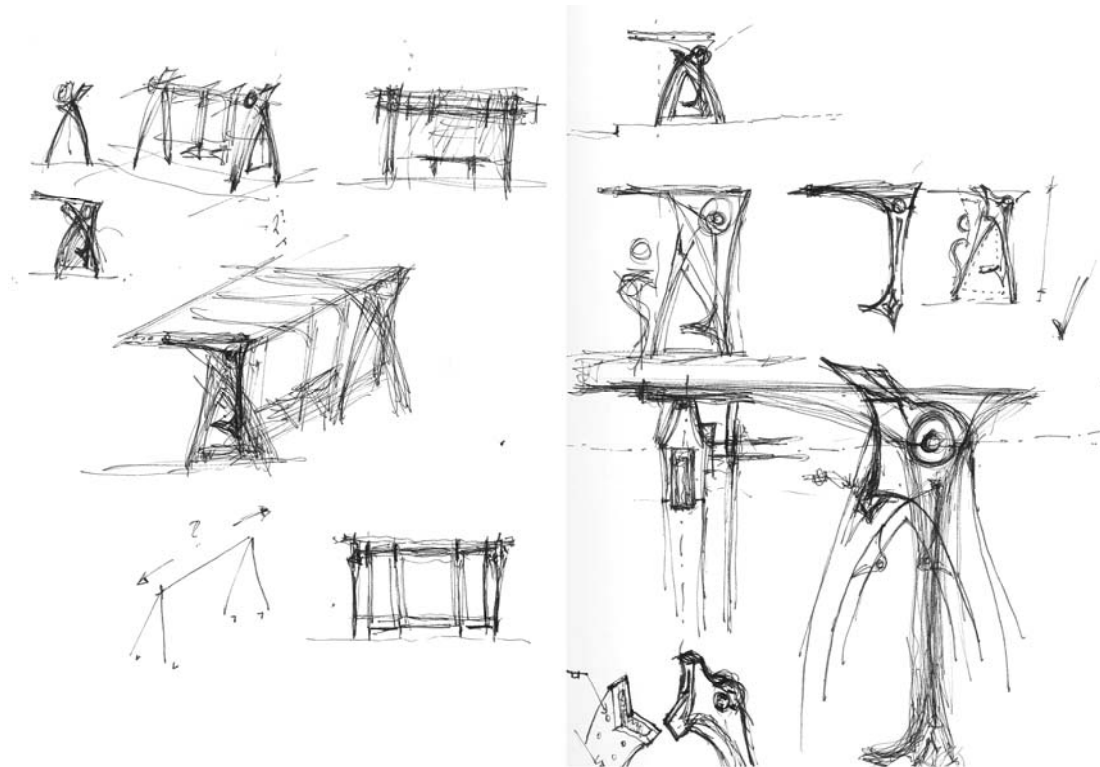

Figure: 7-44 – Small Shelter Conceptual Sketches.

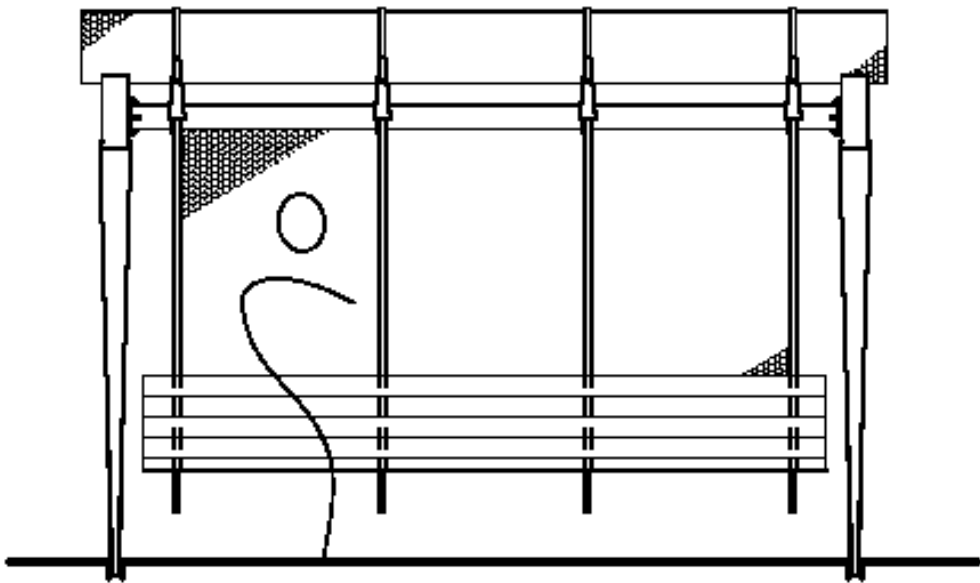
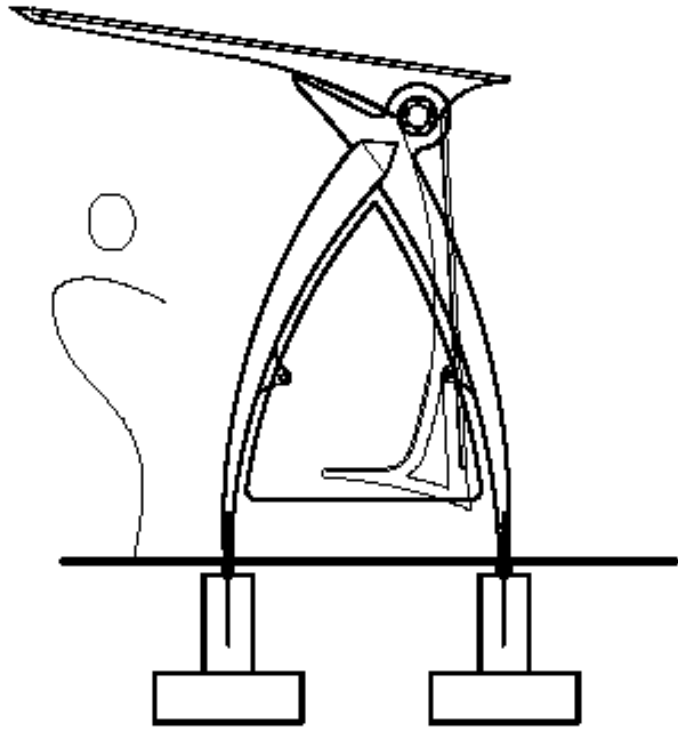

Figure: 7-45 – Small Shelter Orthographic Representation.

Chapter 8: Propositions for Implementation

Implementation of the Kit-of-Parts

Canopies First then the Sky's the Limit

Most likely, the first infrastructural elements to be introduced into this system would be the station stops developed in chapter six of this proposition. Anything from chapter seven would then have a reason for being and onlookers could then relate that kit-of-parts back to the main iconographic elements that were the station stop shelters. It might make sense that some of the graphics and symbols used to describe the station stops might appear in earlier advertising for initial implementation of these elements, but anything else would probably not appear until well after the stops were constructed and established in society.

Ideally combinations of these elements could be used when specific site concerns arise during the design phase for the actual locating of these elements. Later elements like the way-finding post would appear after populated areas received their first station stop. Additionally the wire supports would likely have to be installed very soon after the stops themselves in order to actually get the trains moving. Other than that the sky is the limit for an order to, or an amount of infrastructural details that could be developed for this public transportation system.

Notes on Implementation of Materials

Material Finishes

Questions have arisen regarding the proposed finishes of the materials used during these investigations. Luckily one of the materials proposed does not require any additional finishing coatings. The polycarbonate material suggested typically comes factory extruded and ready for any interior or exterior use. If any additional coatings or screened laminate products were used, they would also be coming from factory settings and would not need any additional coatings after being fixed to structural supports.

Other steel elements would have to have anti corrosive coatings added after installation when laying in exterior conditions. Since stainless steel elements would probably be too expensive for normal use and application, except where absolutely necessary, companies manufacturing zinc based coatings would be preferred. Certain companies have multi layer sealant, coating, sealant, finish coatings that can simply be painted on after everything has been installed. These coatings are just as effective if the entire structure was entirely made of stainless steel but for much less the cost.

Site Specific Implementation

Notes on Site Selection

During the many iterations of station stop design progression, methods for incorporating them into specific sites arose. The entire phase-one of the purple line was traveled and documented with regards to currently proposed station stop

locations. A few specific sites were examined briefly to attempt to contextually place some of these designs. However, multiple issues arose quickly that complicated the designs and would not have allowed research into other detailed interventions throughout the system, if site conditions were completely figured out. However these simple placements of structure on a few stop locations nearby helped to generate the multiple station stop configurations (single, double and small single sided).

Special attention was initially paid to sites near the River Road Stop location (a site in the middle of nowhere with very minimal context), a Silver Spring, Maryland Stop location (a more urban site condition), and two sites on the University of Maryland campus. These campus sites are currently in question as to which would become the actual site for the purple line station stop, and that is due roughly to currently debates surrounding exact route and track placement.

The first proposed stop location, on Campus Drive, near the student union, is already an existing bus hub for the city and for the campus. This location is highly trafficked by pedestrians and vehicles alike. If this site was chosen for this new public transportation system, a proposal to close Campus Drive to non-emergency vehicle traffic during the day would likely occur.

The second stop location would take place across the universities main mall near Preinkert Hall. This would assume the purple line route be implemented to the south of the mall and would end up on Mowatt Lane going between Somerset and Preinkert

Halls. This location has lots of potential due to proximity to the main university library and the school of business. Additionally campus drive could remain open during the day, which would please many of those against this system implementation.

The Campus Drive site was briefly touched upon for structural implementation. A combination of the double sided stop proposal and a single sided stop proposal could form a nice replacement for the current bus shelters at this location. Again issues of topography were ignored and more investigation would obviously need to occur for inaction of such a structural arrangement, but either way, this stop configuration could provide a unique gateway to the campus at this very central transportation hub.

Figure: 8-1 – Proposed Track Lines Traversing Campus Drive.

Figure: 8-2 – Proposed Stop Locations at Existing Transportation Hub Near Student Union.

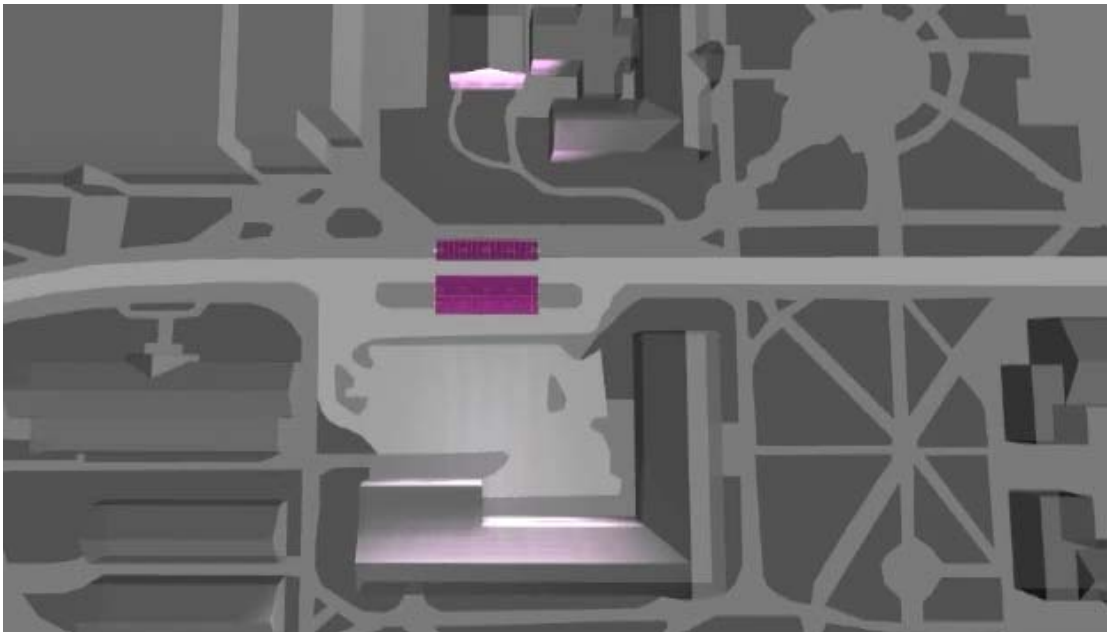

Figure: 8-3 – Schematic Orientation Aerial for Conceptual Animations Showing Station Stop Configuration of One Double-Sided and One Single Sided Stop Flanking Campus Drive.



Figure: 8-4 – Campus Drive Stop Proposed View Looking Southwest



Figure: 8-5 – Campus Drive Stop Proposed View Looking West



Figure: 8-6 – Campus Drive Stop Proposed View Looking East

The Preinkert Hall site was examined more closely with regards to how pedestrian activity might be affected by the introduction of one of these station stops. The exact location actually did not require too much alteration to place an entire four bay stop as proposed and modeled. This station stop could accommodate the entire length of the Siemens S70 light rail car, and would not take too much site modification to enact. A few pathways could be diverted to go around this mirrored single sided stop configuration and another gateway could be made at this important campus location.

Figure: 8-7 – Proposed Track Lines Traversing South Campus.

Figure: 8-8 – Proposed Stop Locations Near Preinkert Hall.

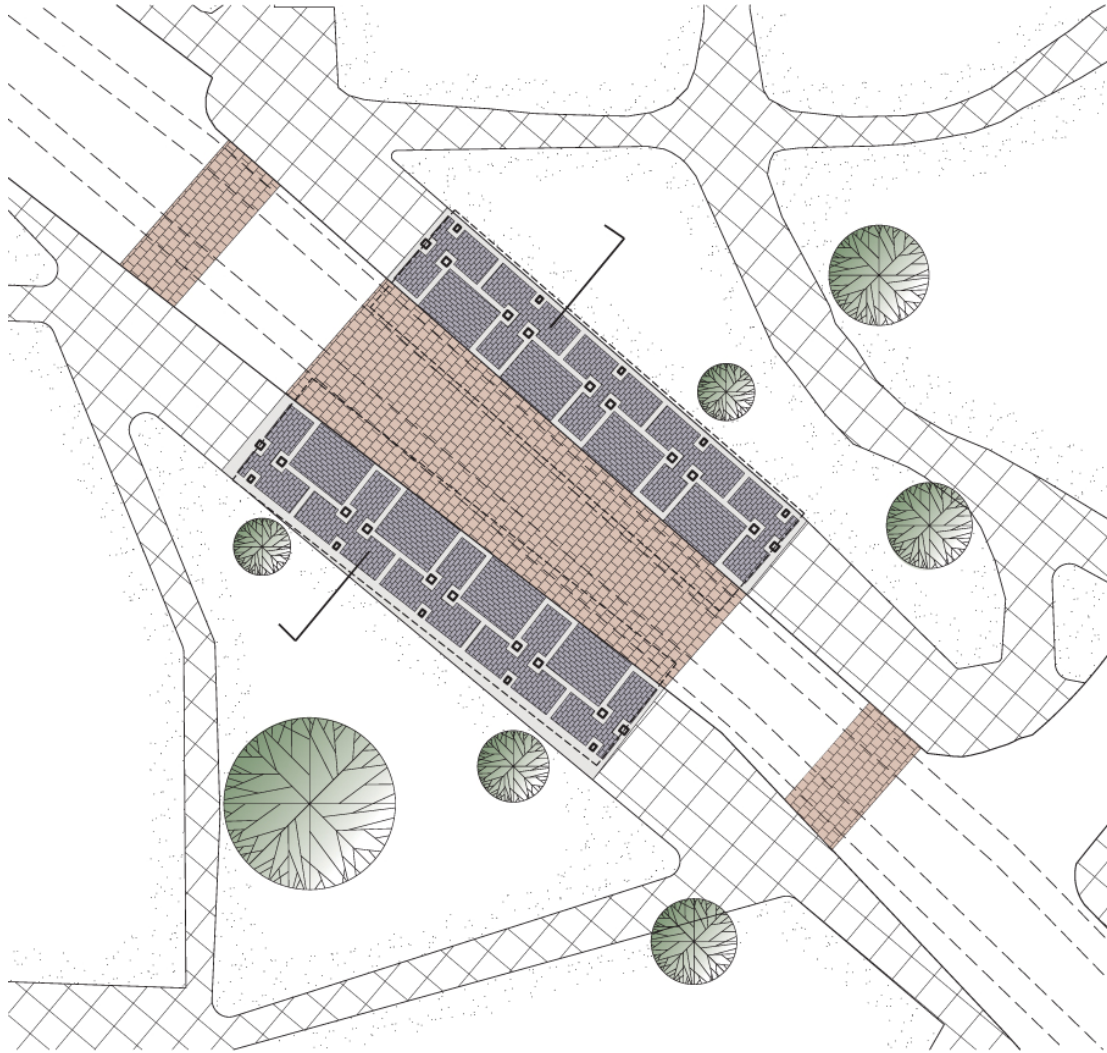

Figure: 8-9 – Proposed Site Modifications Near Preinkert Hall Station Stop.

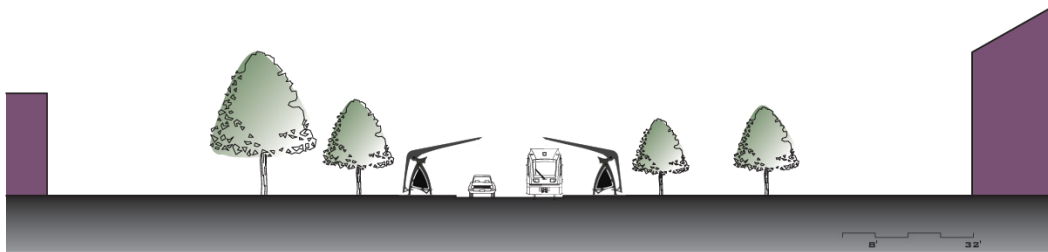

Figure: 8-10 – Proposed Site Section Through Preinkert Hall Station Stop.

It would be interesting to further investigate how the advent of this station stop might affect the adjoining site. Brief studies were taken into how paving patterns and walk conditions would vary when coming into contact with this implementation. It might be a nice effect to hear road vibrations change from blacktop to brick pavers when one rode through this gateway in a car. Rhythms or sets of paving patterns as one approached these stops also became a suggestion. Either way these structures would drastically impact the sites in which they were placed. Other details could be developed to interface with a variety of existing ground conditions, landscaping features, and the like. Hopefully the guidelines proposed here would keep all of these elements supportive, and integral to the structures placed for this new system of public transportation. Careful consideration should be taken with this regard, or these structures will not exhibit the desired permanent and established feel necessary to attract ridership. If these structures simply land on specific sites, they may feel as inhospitable as some of the current bus shelters currently in place around the region. Elements that appear they could change or wash away at anytime are not ones that should become the image of this infrastructural system.

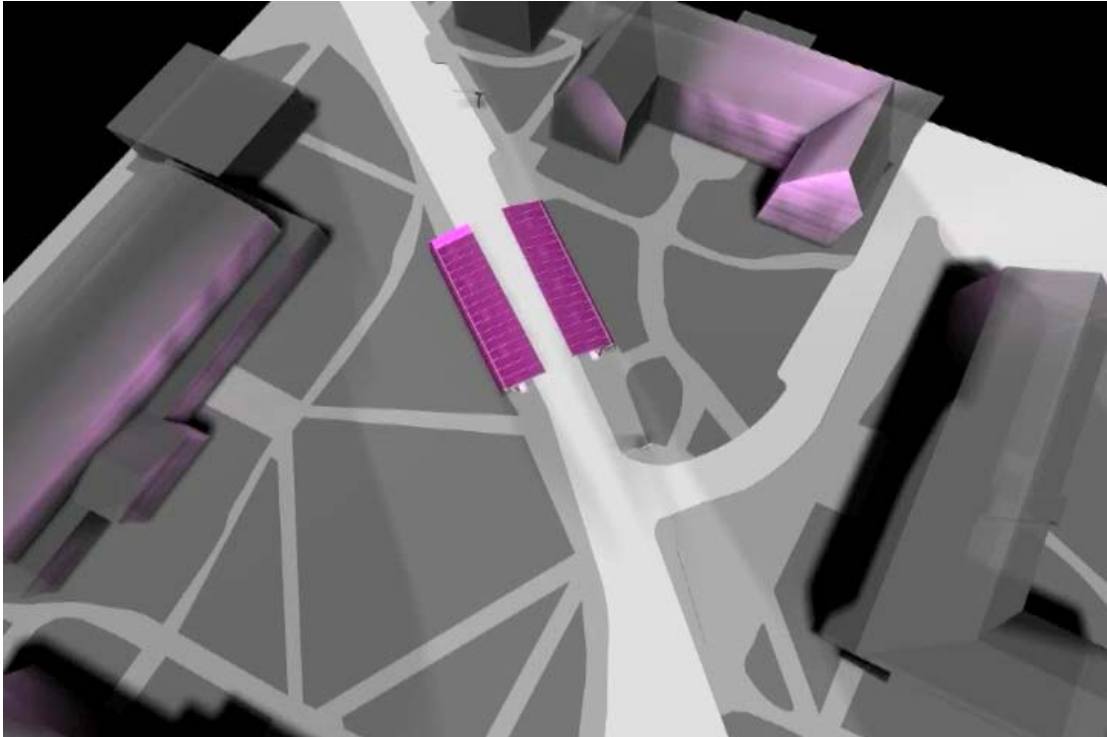

Figure: 8-11 – Schematic Orientation Aerial for Conceptual Animations Showing Station Stop Configuration of Two Mirrored Single Sided Stops Flanking Mowatt Lane.



Figure: 8-12 – Preinkert Hall Stop Proposed View Looking Southeast

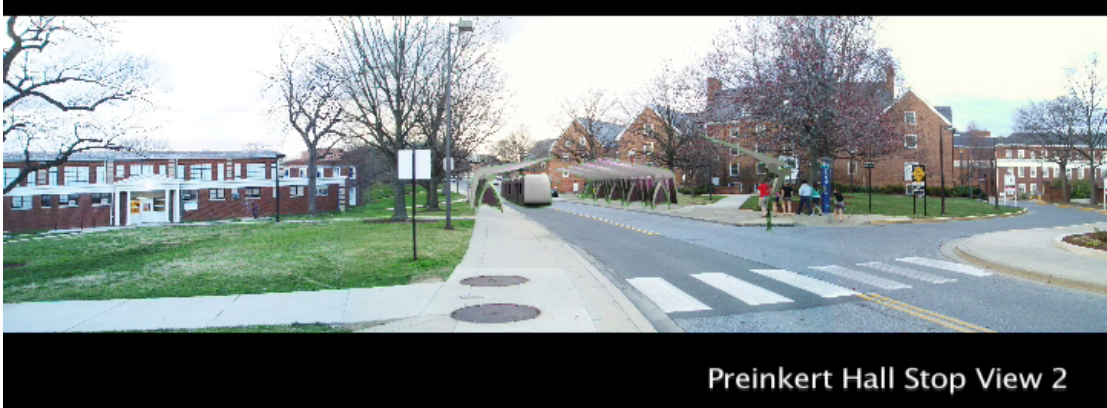

Figure: 8-13 – Preinkert Hall Stop Proposed View Looking West



Figure: 8-14 – Preinkert Hall Stop Proposed View Looking Southwest

Chapter 9: Commentary on Detail Design and Development in the Profession of Architecture

Historical Practices

The knowledge of details and of the related skills was the necessary means for the architect to practice his profession, since it was his task to select the appropriate workers for the appropriate details. (Frascari 25)

How Things Used To Be Done

The field of architecture has changed drastically over time, especially with regards to the amount of interaction with people who actually construct the things that have been designed. Originally the architect was also a craftsman, builder, organizer, and mathematician. The architect would have a direct knowledge with all of the constructional fields and would play a very active role on-site while works were being constructed. Materials would sometimes be hand chosen by the architect and even the final location of each material unit might be influenced by his eye or hand.

Back when there were no official construction documents and no computers to figure out complicated joints and details, an architect had to coordinate many master craftsmen. He had to work side by side with and be in a constant series of dialogues with these people in order to see the intended result come to fruition. The architect had a very active role in every design and detail decision on a project. However the architect many times left detail considerations up to those master craftsmen who took

the time to pause and, based on their high degree of specialization, made sure that precise care was enacted during this construction. Many great works of architecture were constructed with this approach to the profession. It is extremely amazing how precise and detailed certain things have been made before the advent of computers and construction documents.

Current Practices

One problem in today's society is that the 'various building trades no longer infer the construction of details from design drawings. Details, now, are studied and resolved on the drawing board. The detail is now seen as a production drawing.' (Frascari 25)

How Things Are Done Now

Not to say that current architects do not value how a building is constructed, but lots of time, many issues are overlooked in the design of a project. Many times, the details that are left up to contractors and construction companies to figure out are finished in a way that leaves much to be desired. Many small details in a project, that could become the place where human experience is heightened, become leftovers on a project, and are simply left for an underpaid craftsman to quickly finish.

The issue of money has become a constant battle for architects. Architects are expected to coordinate everything in a project, know how everything goes together, and are expected to produce drawings and explanations of that knowledge in a typically short time period. Developers want to build things to make money.

Architects want to give them the ability to make money faster so they can in turn

make money. Sometime details are simply recycled from project to project in order for a quick turnover of information. Details should be unique to projects to set them apart, to give each design a unique quality that can become the embodiment of an architectural expression of the designer. However, issues of efficiency in construction are certainly valid points for consideration when designing large projects. Details can be repeated with regards to construction types especially when a tectonic approach is not expressed. Certain constructional practices are repeated for a reason however, but architects cannot be too careful in using previously easy-to-acquire computer-generated details for a multitude of projects.

Nonetheless details are the opportunity for a designer to explore a level of completeness in a project. If the overall massing of a building is figured out, only one step has been achieved. No one will ever experience an aerial view of a building that an architect designs except in rare occasions. Humans experience the details as they traverse through, about, or around a building. People touch, feel, and sense architecture through these carefully articulated moments. There should be no corner, no joint, and no screw left out from the thoughts of a true designer.

Proposed Practices

How Things Should Be Done

In working alongside consultants throughout this entire proposition, a level of understanding was established. This mutual education and collaboration can be seen in the final outcomes of many of these details and implementations. An active

dialogue that can be started at the beginning of a project will only positively inform the desired result. By getting to work with a structural consultant, who for once was not about simplifying or diminishing the intent of the architecture, the end designs were drastically improved.

There will always be compromises in these different fields as each assumes a new degree of liability in the world we now live. Architects should still be the ones to initiate this dialogue early on in the design process and be forceful with regards to maintaining a high level of design decisions. Attempts should be made to not compromise details in an attempt to reduce petty financial means. Again, the importance for a positive and influential experience for inhabitants should be the goal of any work of architecture. That experience can only become more enriched after a thoughtful attention to detail has been pursued. The profession as a whole would gain lots of respect and recognition if this simple ideal could be achieved.

Chapter 10: Conclusions

Missed Opportunities

Full Scale Installations

An original end goal of this proposition was to produce full scale versions of these implementations and detail designs. Now, while it may not have been feasible to try constructing an entire station stop, or even a bus stop, something like a chair should have been possible. However, the amount of details pursued in the end proved to be more rewarding than actually modeling some of them at full scale. Digital technology made seeing them in context possible, even if they were not physically present during the final presentation.

Large Scale Material Studies

Unfortunately, time and budget prevented explorations with actual steel members for many of these details. Once that sole material was chosen to represent the majority of this infrastructural system, a goal was to have at least one full scale mock up of one of the roof slices, or other detail connection in metal. Complications arose near the end of the process, but with a reasonable understanding of structural principles and the forces acting on most of these details, real installation does not seem too far off.

Within a few steps from shop drawings or construction documents, many of these details reached an appropriate level of development to satisfy the author. Nonetheless it would be interesting to see how many changes would have to be made to reach

actual implementation after working hands on with fabricators, structural engineers, and transportation specialists.

Detail versus Motif versus Style

Wording and Jargon

Some late comments and criticism surrounding this proposition dealt with whether a style, motif, or detail was in the end, established. It may come down to semantics in the end whether one is more correct over the other, but certainly there is room for discussion. Details, which could be defined as ‘small parts of a whole,’ were created (<http://www.merriam-webster.com/dictionary/detail>). According to Frascari, a ‘plot was developed to tell the tale’ of the purple-line. All of these designs for implementation could be related to a whole of parts and ideas that would become the entire purple-line infrastructural system. Certain details, in this case could be left out, but the whole would remain. Yet all together, and after even more details that might be added were developed, the story would simply become more enriched.

A motif was created as well, in that there are many ‘recurring salient thematic elements’ (<http://www.merriam-webster.com/dictionary/motif>) throughout this proposition. Even a ‘repeated design or color,’ could be used to describe some of the outcomes of this thesis. This term, ‘motif,’ however, seems to gain negative criticism within the architectural world. For whatever reason this term implies a level of simplicity and an overarching theme that might not always yield appropriate results.

Based on definition (<http://www.merriam-webster.com/dictionary/style>), a ‘distinctive, quality, or form of something,’ was also established as iconographic elements for these infrastructural elements. A ‘style’ has been created for a variety of elements that could be associated with the purple-line. However, an ‘architectural style’ carries much more meaning than exhibited here. The ‘International Style,’ or ‘Greek Style,’ of architecture become embodiments of a culture, or a technological time period. The purple-line would probably not be located in either of those two realms.

The author would like to believe that the final developments fall into the first two categories. An architectural motif was created for the purple-line based on the abstraction of structural details, and the expression of tectonics. Details were created to explore a variety of joints, both in material connections, and personal, physical interactions. A joint in the circulation of a person became the station stops themselves. However many structural joints such as those between roof and column, column and ground, signage and roof, and even fastener to that being fastened were explored. A story for the purple line has begun, and through the further development of the plot, that being made up of those future details based on the systems prescribed here, the end result will undoubtedly become that much more in depth.

An Interesting Diagram

Abstraction versus Representation and Biomorphic versus Tectonic

Early on in this process an idea about categorizing design methodologies arose. After searching for precedents and attempting to compare many architects doing different things with regard to detail, a more concrete method for exploration was necessary. It was pointed out by a committee member that certain architects being researched embodied differing principles in their design processes. While some architects may embody ideals concerning levels of abstraction, some relied more on ideals of representation to achieve their end results. Some stemmed design from biomorphic principles, while others, tectonic principles.

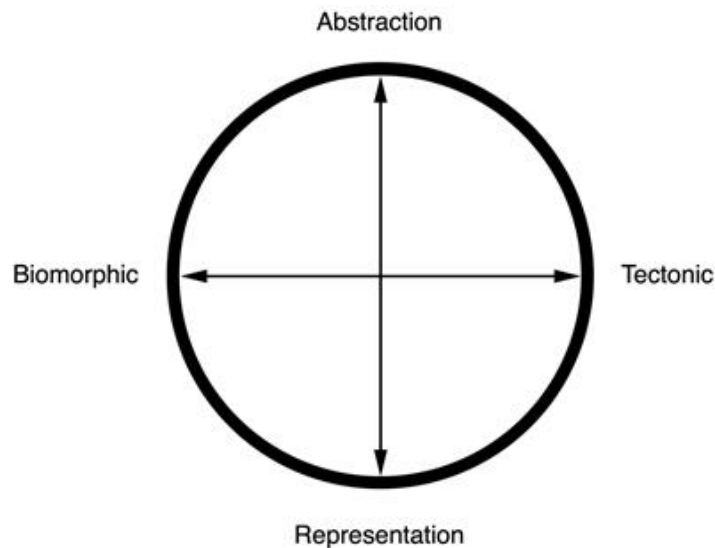

Figure: 10-1 – Positioning Mentor Architects' Methodologies Diagram. Brian Kelly.

This diagram provided for some rhetorical discussion about which quadrant certain architects seemed to be placed. While still up for interpretation, and while many architects differed as well from project to project, generalizations were made regarding a method for comparison. An architect like Calatrava, in the author's

opinion, fell more into the biomorphic and abstraction categories, while an architect like Cutler fell more towards tectonic representation. While most of the end detail designs here may appear to have innate biomorphic qualities, they fall more into a tectonic visual language embodying an abstraction based on basic structural forces.

While this diagram may not yield lots of future discussion, it was an interesting exercise to begin to provide a basis for a comparison of research. As well, categorizing the details at the end of this process seems to bring the proposition to a full circle conclusion. Ideas from all of the architects in question proved to be very influential at the tail end of this process, however keeping all of the interesting details being researched simplified into these categories, allowed the author to easily see what types of influences became the basis for the majority of the detail development. With no intended goal from the beginning of this proposition with this regard, it was interesting to see what the end result of this process became.

Reversing the Process

Feasibility

It should be noted that ideas stemming from details can certainly inform a broader, holistic design process. The analysis procedures used earlier involving the architecture of Calatrava and Cutler Anderson, for example, showed this in that initial detail explorations yielded ideas about a resultant process. However, it may seem that this proposition ended up searching for a problem, that being the need for a new infrastructure to signify the proposed ‘purple-line,’ and solved it using traditional

design methods. There needed to be station stops, so they were developed using relative constraints based on items like track layout and train car dimensions. Other cataloged elements were then designed based on their relative need in a public transportation setting such as a trash or recycle bin, pamphlet holders, wire supporting mechanisms, all the way to way-finding signage. The ‘design’ in the end was the elements that would, and could later, signify the purple-line. The ‘details’ became the abstractions of the structural diagrams and the resolution of the parameters themselves that can inform decisions about the future designs for this system.

The process was reversed in the fact that even after the problem was established, that being a need for development of an infrastructural system, details were designed first. A loose architectural program may have been in place from the beginning, but exact outcomes were not based solely on a specific conditional set of functions. General prototypes for a set of station stops may have been created, but serious issues with site specific conditions were not approached. This would normally be the first step in the typical design process, and would be the next step if these elements were to actually be implemented.

One could argue whether the process was actually reversed over the course of this proposition with the goal of designing elements for a transportation system at the forefront. Nevertheless, studies of details and layers of refinement have led to a developed design for the beginnings of an infrastructural system that could become the iconography for the proposed Washington D.C. Purple-Line light rail initiative.

Bibliography

- Adamson, Glenn. "Thinking Through Craft." New York: Berg, 2007.
- Alexiou, George, and Graham James. Personal telephone interview. 3 Feb 2009.
- Ball, P. "The Self-Made Tapestry: Pattern Formation in Nature." New York: Oxford University Press, 1999.
- Buchanan, Peter. Renzo Piano Building Workshop: complete works. Phaidon Press. London, 1995.
- Callebaut, W. and Rasskin-Gutman, D., eds. "Modularity: Understanding the Development and Evolution of natural Complex Systems." Princeton University Press, 2005.
- Catalogue: Foster and Partners. Prestel. London, 2005.
- Frasconi, Marco. "The Tell-the-Tale Detail." 1981. [VIA 7: the Building of Architecture. "The Tell-the-Tale Detail", Cambridge, Mass: the MIT Press, 1984, pp. 23-37].
- Galiano, L. F. "Organisms and Mechanisms, Metaphors of Architecture," 1982. In Rethinking Technology: A Reader in Architectural Theory, eds. Brahm, W. and Hale, J. A. New York: Routledge, 2007.
- Hoffman, Donald. Frank Lloyd Wright's Robie House: the illustrated story of an architectural masterpiece. Dover Publications. New York, 1984.
- International Terminal Waterloo. Grimshaw Architects. 2008. Accessed 20 Jan 2009. <<http://www.grimshaw-architects.com/print/projectdata.php?id=36>>.
- Johnson, Phillip. "Architectural Details," Architectural Record, 1964. pp. 137-47.
- Kennedy, Alicia. The best of Cutler Anderson architects. Rockport Publishers. Beverly, Massachusetts, 2008.
- Kieran, S. and Timberlake, J. Loblolly House: Elements of a New Architecture. New York: Princeton Architectural Press, 2008.
- Kolarevic, Branko. Ed. "Architecture in the Digital Age: Design and Manufacturing." Spon Press. New York, 2003.

- Leatherbarrow, David & Mostafavi, Mohsen, "Surface Architecture." Cambridge: MIT Press, 2002. Postscript.
- McCullough, M. "Abstracting Craft: The Practiced Digital Hand." Cambridge, Massachusetts: MIT Press, 1996.
- McQuaid, M. "Extreme Textiles: Design for High Performance." New York: Princeton Architectural Press, 2005.
- Ossterhuis, Kas. "File to Factory and Real Time Behavior in Architecture, in Fabrication: Examining the Digital Practice of Architecture." Cambridge, Ontario: ACADIA, 2004.
- Perez, Santiago. "A-Ware: Autonomy, Emergence and the Uncanny." University of South Florida, 2005.
- Perez, Santiago. "Crafting Complexity: Material/Procedure/Form." University of Houston Gerald D. Hines College of Architecture, 2008.
- Perez, Santiago. "EFAB-Environmental Fabrication: Towards a Confluence of Craft and Computing in Prefabricated Component Design." University of Houston Gerald D. Hines College of Architecture, 2008.
- Perez, Santiago. "PolyForm: Biomimetic Surfaces." At the ACADIA 2006 Synthetic Landscapes Conference in Louisville, KY. University of Houston Gerald D. Hines College of Architecture, 2006.
- Perez, Santiago. "The Synthetic Sublime: notes on physical/digital space and form." University of South Florida, 2004.
- Perez, Santiago. "Towards a New Tactility: embodied material consciousness and MAKING." University of Houston Gerald D. Hines College of Architecture, 2008.
- Quinan, Jack. Frank Lloyd Wright's Martin House: architecture as portraiture. Princeton Architectural Press. New York, 2004.
- Schodek, D. L. and Addington, M. "Smart Materials and Technologies in Architecture." Boston: Elsevier / Architectural Press, 2004.
- Sennett, Richard. "The Sense of Touch, in Tracing Architecture." Architectural Design Vol. 68, No. 3/4 March-April 1998, p. 19.
- TCRP Report 2: Applicability of low-floor light rail vehicles in North America. Federal Transit Administration. National Academy Press. Washington, D.C., 1995. Accessed 11 Feb 2009. <<http://www.tcrponline.org/bin/publications.pl?>

mode=abstract&cat_id=23&pub_id=750>.

TCRP Report 17: Integration of Light Rail Transit into City Streets. Federal Transit Administration. National Academy Press. Washington, D.C., 1996. Accessed 11 Feb 2009. <http://www.tcrponline.org/bin/doc-distr.cgi/TCRP%20RPT%2017-A.pdf?cat_id=23>.

TCRP Report 57: Track Design Handbook for Light Rail Transit. Federal Transit Administration. National Academy Press. Washington, D.C., 2000. Accessed 11 Feb 2009. <http://www.tcrponline.org/bin/publications.pl?mode=abstract&cat_id=23&pub_id=805>.

TCRP Report 69: Light Rail Service, Pedestrian and Vehicular Safety. Federal Transit Administration. National Academy Press. Washington, D.C., 2001. Accessed 11 Feb 2009. <http://www.tcrponline.org/bin/doc-distr.cgi/tcrp_rpt_69.pdf?cat_id=23>.

Turner, J. S. "The Tinkerer's Accomplice: How Design Emerges from Life Itself." Cambridge, Massachusetts: Harvard University Press, 2007.

Tzonis, Alexander. Santiago Calatrava: The Complete Works. Rizzoli; Enfield: Publishers Group UK. New York, 2007.

Wachsmann, K. "The Turning Point of Building: Structure and Design." New York: Reinhold Publishing, 1961.