

## ABSTRACT

Title of Thesis: NURTURING THE CHILD: AN ARCHITECTURE OF  
COMMUNITY, LANDSCAPE AND LEARNING

Catherine Marie Stratton Treadway, Masters of  
Architecture, 2009

Thesis Directed By: Associate Professor Brian Kelly  
School of Architecture, Planning and Preservation

This thesis explores the making of place for all preschool children, those with special needs and those considered to be “typically developing.” Scale, materiality, light and shadow, color, the four fundamental elements of nature, and the nature of ritual and routine all play a role in the children’s experience of place and are explored here as part of the design process.

This thesis asks, “What are the contributions that architecture and landscape can make towards nurturing the whole child including children with diverse needs?” The result is a supportive learning and healing environment for children who are defined as having special needs and their “typically developing” peers. A landscape of learning and play will be a significant focus.

To support the children and their families, a range of community involvement will be incorporated, and the large recreation center site will be redeveloped as community space.

NURTURING THE CHILD: AN ARCHITECTURE OF COMMUNITY, LANDSCAPE  
AND LEARNING

by

Catherine Marie Stratton Treadway

Thesis submitted to the Faculty of the Graduate School of the  
University of Maryland, College Park in partial fulfillment  
of the requirements for the degree of  
Master of Architecture  
2009

Advisory Committee:

Assistant Professor Isaac Williams, Chair  
Senior Lecturer Courtney Miller Bellairs  
Associate Professor Brian Kelly

©Copyright by

Catherine Marie Stratton Treadway

2009

## Table of Contents

Chapter 1: Defining the Problem .....	1
Chapter 2: Buildings that Heal and Nurture.....	3
Chapter 3: Children and the Importance of Play .....	16
Chapter 4: People as Program .....	19
Chapter 5: City as Site .....	54
Chapter 6: Design Opportunities and Challenges .....	74
Chapter 7: Design Proposal .....	79
Chapter 8: Critique and Response .....	100
Chapter 9: Concluding Remarks .....	109
Bibliography	

## Table of Figures

Figure 1 A deep window softens the light. Watercolor. Stratton Treadway, 2008. ....	3
Figure 2 A chapel space buffers light in a similar way. Watercolor. Stratton Treadway, 2008. ....	4
Figure 3 A meander allows for pooling of energy and ebbing and flowing of activity with no particular goal. Watercolor. Stratton Treadway, 2008. ....	5
Figure 4 An axial, directional path appears to have a more overt destination. Watercolor. Stratton Treadway, 2008. ....	5
Figure 5 An exploration of light and shadow along a path within the earth and beside the water. Watercolor. Stratton Treadway, 2008. ....	6
Figure 6 A shell protects the soft animal within. Watercolor. Stratton Treadway 2008. ...	7
Figure 7 How might a shell make a building? Collage. Stratton Treadway 2008. ....	7
Figure 8 Some children have physical and/or emotional scars. A scar can harden or diffuse over time. Watercolor. Stratton Treadway, 2008. ....	8
Figure 9 A scar can be hidden or exposed. Collage. Stratton Treadway, 2008. ....	8
Figure 10 Constellation of Health and Healing. Pen and Colored Pencil. Stratton Treadway, 2008. ....	9
Figure 11 Convent at Tlalpan. Martinez pg 110. ....	10
Figure 12 Casa Gilardi. Quiet Revolutionary, pg 237. And Casa Galvez QR, pg 131. ...	11
Figure 13 Hill House interior with nooks. (internet) ....	11
Figure 14 <a href="http://rogersshepherd.com/WIW/solution5/crow2.html">http://rogersshepherd.com/WIW/solution5/crow2.html</a> ....	12
Figure 15 <a href="http://rogersshepherd.com/WIW/solution5/crow2.html">http://rogersshepherd.com/WIW/solution5/crow2.html</a> ....	13
Figure 16 Tappen Springs Park in Portland Oregon. The undulating, corrugated wall, buffers city noises. Stratton Treadway. June 2008. ....	13
Figure 17 <a href="http://www.mobot.org/press/Media_Room_Images/Garden_Spring/downloadable/JapaneseGarden_JJennings.jpg">http://www.mobot.org/press/Media_Room_Images/Garden_Spring/downloadable/JapaneseGarden_JJennings.jpg</a> ....	14
Figure 18 Plan of van Eyck playground showing paving pattern, round sand pit and the location of other apparatus. (Internet) ....	15
Figure 19 Aerial view of van Eyck playground showing the crowd in the sand pit. Notice how the climbing apparatus (in lower portion of image) creates a sort of fence between the play space and the street. (Internet) ....	15
Figure 20 The author's nephew squeezes into a tight space. Stratton Treadway 2007. ...	16
Figure 21 These boys have options for climbing, running and jumping. Friedberg, Play/Interplay. ....	17
Figure 22 Child in Community. Pen and Color Pencil. Stratton Treadway 2008. ....	20
Figure 23 Early diagram about the kinds of support therapies a preschool age child with special needs might require. Pen and Color Pencil on Trace. Stratton Treadway 2008. ....	21
Figure 24 An early diagram showing the physical places in which healing might take place. Pen and Color Pencil on Trace. Stratton Treadway 2008. ....	22
Figure 25 Early diagrams about people who support children with special needs. Pen and Color Pencil on Trace. Stratton Treadway 2008. ....	22
Figure 26 Column two contains activities and column three, architectural elements. Pen and Color Pencil on Trace. Stratton Treadway 2008. ....	23

Figure 27 Diagram of ideas from Christopher Day incorporating the four elements into a learning and play environment for children. Stratton Treadway 2008.....	28
Figure 28 Plan diagram showing overall divisions of space. Stratton Treadway 2009... 30	30
Figure 29 The great room for intergenerational activities. Photo Stratton Treadway November 2008. ....	31
Figure 30 Gathering and dining spaces are located pretty far away from the children's classrooms. Stratton Treadway 2009. ....	32
Figure 31 Classroom configuration showing main lobby and reception desk and check-in desk for Child Development Center. Stratton Treadway 2009. ....	32
Figure 32 How children enter their classrooms and pass by the check-in desk. Stratton Treadway 2009. ....	33
Figure 33 A preschool classroom with cots, a perch and a place to be quiet underneath but not room for making more than one mess. Stratton Treadway 2008.....	33
Figure 34 Access to rubberized outdoor area from each classroom. Stratton Treadway 2009.....	34
Figure 35 A special "bowl" to accommodate the spinning needs of autistic children (and many other children.) Made by Kompan. Stratton Treadway 2008.....	35
Figure 36 A water and sand table at wheelchair height. Made by Kompan. Note the narrowness of the outdoor space. Stratton Treadway 2008.....	35
Figure 37 Sensory bumps and spinning wheels to accommodate sensory needs. Made by Kompan. Stratton Treadway 2008.....	35
Figure 38 Overall plan of the classroom showing the gated activity areas and other spaces. Stratton Treadway 2009.....	37
Figure 39 View from the doorway close to the main entrance showing the overall layout of the classroom with its multiple gated activity areas and eating area in the center. The class schedule is on the back wall, big enough to be read across the room. Photo Stratton Treadway 2008.....	38
Figure 40 Circle time area has rocking chairs to accommodate children who can't sit "still" without being in motion. All children regardless of diagnosis can use the rockers. The teacher leads songs and stories with about half the class at any one time Photo Stratton Treadway 2008.....	38
Figure 41 A picture board indicates who is here today. Photo Stratton Treadway 2008. ....	39
Figure 42 A laminated sign reminds everyone to sing the hand-washing song. There is a song for getting through each routine. Photo Stratton Treadway 2008.....	40
Figure 43 Bumpy, shiny boards in the block area accommodate the need for some children for sensory stimulation. The small holes in the pegboard also accommodate this need. Photo Stratton Treadway 2008.....	40
Figure 44 Non verbal children must ask permission with a picture to have the gate opened. The teacher has cut down the gate herself for her small pupils. Photo Stratton Treadway 2008.....	41
Figure 45 Plan showing L-shaped classroom for older children and a typical classroom for the younger children. Stratton Treadway 2009.....	42
Figure 46 Relationship between the classrooms for young children and the lobby and reception area. Stratton Treadway 2009. ....	43

Figure 47 Young Children must pass the reception desk to get to their protected wing of the building. Stratton Treadway 2009. ....	43
Figure 48 The relationship of the children's wing to the shared resources of the school – art room, library, play room and auditorium. Stratton Treadway 2009.....	44
Figure 49 The younger the child the closer their classroom is to their outdoor play space. Stratton Treadway 2009.....	44
Figure 50 Google Maps site photo showing the outdoor spaces associated with the classrooms and classroom wings. Diagram by Stratton Treadway 2009.....	45
Figure 51 The Asilo includes large indoor spaces for gathering and for eating together. The offices are located near the front entrance. Stratton Treadway 2009. ....	46
Figure 52 The courtyard and its indoor extension form the heart of the building. Stratton Treadway 2009. ....	47
Figure 53 The preschool contains four classrooms on the southern side of the building. Each classroom has an outdoor extension (lighter orange). Stratton Treadway 2009. ....	47
Figure 54 Each classroom has direct access to the out-of-doors. To get to the courtyard, one has to go through a hallway. Stratton Treadway 2009.....	48
Figure 55 Children cross the gathering space to reach the cafeteria where they eat together – an important community socialization ritual. Stratton Treadway 2009. ....	48
Figure 56 The ritual of gathering in the morning. Stratton Treadway 2009.....	49
Figure 57 The leaving ritual. Stratton Treadway 2009.....	50
Figure 58 The 3000 sf piazza is the heart of the building. Two interior courtyards let light into the interior of the building. Stratton Treadway 2009.....	51
Figure 59 Classrooms at the corners of the building. The classroom entrances are connected to the piazza but acoustically and visually buffered by the cloakrooms. Stratton Treadway 2009.....	51
Figure 60 Food preparation (900sf) and eating together takes place in the piazza. Stratton Treadway 2009.....	52
Figure 61 Children enter the piazza space and then filter to their classrooms. Stratton Treadway 2009. ....	52
Figure 62 The classrooms are actually larger spaces with the addition of dedicated music and art rooms. A larger art workshop serves the entire school with its entry off the piazza. (A translucent wall visually connects that workshop to the piazza space.) Stratton Treadway 2009.....	53
Figure 63 Children access the outdoors from their classrooms. Or they can go from the piazza into the interior courtyards. Stratton Treadway 2009. ....	53
Figure 64 The Edgewood Recreation Center site. Stratton Treadway 2009.....	55
Figure 65 East West section. Stratton Treadway 2009. ....	56
Figure 66 North South section. Stratton Treadway 2009.....	57
Figure 67 A 1928 Sanborn map shows the overall relationship between the proposed site, Florida Avenue and the large land-grant institutions in the center of the city. Stratton Treadway 2008. ....	58
Figure 68 McMillan Sand Filtration Plant visible from North Capitol Street. <a href="http://upload.wikimedia.org/wikipedia/commons/e/e9/McMillan_Sand_Filtration.JPG">http://upload.wikimedia.org/wikipedia/commons/e/e9/McMillan_Sand_Filtration.JPG</a> .....	59

Figure 69 The current configuration of large institutions north of Florida Avenue and their relationship to the proposed site. Google Maps. Stratton Treadway 2008. ....	60
Figure 70 Buildings in the landscape on the Trinity College campus. Google Maps. Stratton Treadway 2009.....	61
Figure 71 Buildings in the urban grid. Google Maps. Stratton Treadway 2009. ....	61
Figure 72 The Edgewood site lies at the junction between landscape and urban grid, opening up design opportunities. Google Maps. Stratton Treadway 2009.....	62
Figure 73 The site is bordered mostly by single family homes and small apartment buildings. Google Maps. Stratton Treadway 2009.....	62
Figure 74 The site has urban edges and landscape edges. Google Maps. Stratton Treadway 2009. ....	63
Figure 75 A 1928 Sanborn map shows that Evarts and 3rd Streets used to continue on through the site. Stratton Treadway 2009.....	64
Figure 76 Hierarchy of roads around the site. Google Maps. Stratton Treadway 2009. .	65
Figure 77 The afternoon sun is a problem for western facing activities. Google Maps. Stratton Treadway 2009.....	65
Figure 78 Views from the high point. Stratton Treadway 2009 .....	67
Figure 79 Current configuration of the site as a recreation center. Colors indicate the venues intended for use by various age groups. Stratton Treadway 2009.....	67
Figure 80 Fences, walls and recreation venues. Stratton Treadway 2009.....	68
Figure 81 Circulation paths which do not always follow sidewalks and paths. Stratton Treadway 2009 .....	69
Figure 82 Ways in which the author observed the site being used. Stratton Treadway 2009.....	69
Figure 83 To the east of the Recreation Center is a narrow and hidden passage which invites antisocial behavior. Stratton Treadway 2008.....	70
Figure 84 Most large trees are located near the high point of the site. Stratton Treadway 2009.....	71
Figure 85 Water pools on the playing field after it rains and has no place to go. Stratton Treadway 2009. ....	71
Figure 86 Diagram comparing the large area of low fields to the high plateau. Stratton Treadway 2009.....	72
Figure 87 The disposition of functions within Shaed Elementary School. Stratton Treadway 2009. ....	73
Figure 88 Diagram showing the opportunities of the site. Stratton Treadway 2009. ....	75
Figure 89 Regulating lines on site. Stratton Treadway 2009.....	76
Figure 90 Building as retaining wall with community space at south end of site. Entrance to school is from upper level. Stratton Treadway 2009.....	77
Figure 91 Building as retaining wall with community space to west. Entrance for children on top and entrance for the community to the west. Stratton Treadway 2009.....	77
Figure 92 L-shaped configuration makes community courtyard on Evarts Street. There is one entrance to the building with the Stratton Treadway 2009. ....	78
Figure 93 Early scheme showing front door on Evarts Street with children’s garden in back of site. Stratton Treadway 2009. ....	78



Figure 94 Scheme at A6 showing the interior children’s garden on the hill and the entire precinct surrounded by the garden wall. The front door is on Evarts Street. Stratton Treadway 2009. ....	79
Figure 95 Building Layers Diagram. Stratton Treadway 2009. ....	80
Figure 96 Site plan (A6) showing garden wall, interior garden and orchard and relationship of building to community. Stratton Treadway 2009. ....	81
Figure 97 Long section through the site showing the entry on Evarts Street, up through the stair and the 2-3-year-old-classroom, the school garden and the community garden. Stratton Treadway 2009. ....	83
Figure 98 Ground floor plan (A6). Stratton Treadway 2009. ....	84
Figure 99 Evarts Street facade (A6) is the face to the community. Stratton Treadway 2009. ....	85
Figure 100 Entry from Evarts Street. A family enters the building and a father and child play outside. Stratton Treadway 2009. ....	86
Figure 101 Plan by Ritual Diagram 1. Stratton Treadway 2009. ....	87
Figure 102 Plan by Ritual Diagram 2. Stratton Treadway 2009. ....	87
Figure 103 Two-story plan by ritual. Stratton Treadway 2009. ....	88
Figure 104 School-level plan showing classroom clusters, entry, and classroom porches. Stratton Treadway 2009. ....	89
Figure 105 Section showing a performance in the gathering space and the relationship of the two gardens. Stratton Treadway 2009. ....	90
Figure 106 School garden is designed around an existing hill with mature oak trees. It is designed to give the children experiences with the elements of nature and the seasonal cycles. Stratton Treadway 2009. ....	91
Figure 107 Section through the piazza space looking into the garden showing the way the butterfly roofs overlap the space and drain into the water pool and cistern. Stratton Treadway 2009. ....	92
Figure 108 Plan by ritual for infants and toddlers. Stratton Treadway 2009. ....	93
Figure 109 Plan by ritual for older preschool children. Stratton Treadway 2009. ....	93
Figure 110 Diagrams of classroom based on Olds' ideas. Stratton Treadway 2009. ....	94
Figure 111 Diagram of older child classrooms in the language of Old's diagrams. Stratton Treadway 2009. ....	95
Figure 112 Classroom for 3 and 4-year-olds. Stratton Treadway 2009. ....	96
Figure 113 Pre-K classroom showing active side against garden and quiet side against interior wall. Notice high platforms with activity underneath. Stratton Treadway 2009. ....	97
Figure 114 Classroom for infants. Stratton Treadway 2009. ....	98
Figure 115 Classroom for toddlers. Quiet side to the left and active side to the right. Stratton Treadway 2009. ....	99
Figure 116 February version of the western wall as a bridge with piers. Stratton Treadway 2009. ....	100
Figure 117 Early plan of the project with the building (piazza) pushing out in to the landscape and sponsoring a community landscape to the west. Stratton Treadway 2009. ....	101
Figure 118 Early version of the brick facade. Stratton Treadway 2009. ....	102

Figure 119 Sketch imagining western side of building as a community playspace and porch. Stratton Treadway 2009.....	102
Figure 120 Sketch showing community playspace and brick wall of garden alternating with the landscape as it rolls down the hill. Stratton Treadway 2009.....	103
Figure 121 Revised site plan showing development of western landscape and new stair which engages the garden. Stratton Treadway 2009.....	104
Figure 122 A western garden wall which responds to and engages the landscape. Stratton Treadway 2009.....	104
Figure 123 Revised school plan showing the relationship between the stair and the western landscape and the two gardens. Stratton Treadway 2009.....	105
Figure 124 Earlier iteration of entry showing a domestic scale porch. Stratton Treadway 2009.....	107
Figure 125 Revised Evarts Street facade. Stratton Treadway 2009.....	107
Figure 126 Revised ground floor plan. Stratton Treadway 2009.....	108

## **Chapter 1: Defining the Problem**

Children are being diagnosed with cognitive, behavioral and learning difficulties with greater frequency today than in the past, partially due to the refinement of diagnostic techniques and increased vigilance on the part of parents, pediatricians and teaching professionals. If minor problems are diagnosed and treated early, a child might be able to join his or her typically developing peers in a traditional classroom setting. Long term, these children who began their educational careers with a label can become adults who no longer require extra support or accommodation to participate fully in the adult world of choices and responsibilities.

An inclusive preschool setting with adaptive features for children with special needs allows all children to develop and grow at their own rate. Many times the children do not know who among them carries a label or diagnosis. This is as it should be. Good architecture and landscape can support the nurturing of the whole child and all children.

Because of the level of poverty of many families in Washington DC, the city government plays a big role in providing care for young children in general. For example, ahead of other area jurisdictions, the District has sought to provide pre-programs at all elementary schools and is now seeking to bring Head Start programs to every qualified child in its jurisdiction. The city understands that a commitment to education has to begin as early as possible. This commitment extends to children with special needs to whom the District provides resources by partnering with agencies such as Easter Seals.

This thesis explores the idea that architecture and landscape can provide a healing and nurturing space for the education of preschool age children with special needs – including children with a spectrum of cognitive and behavioral issues.

## Chapter 2: Buildings that Heal and Nurture

### Poetics

The built environment and surrounding landscape affect us profoundly. This has been documented in the psychological literature. Buildings that heal the soul, according to Christopher Day,<sup>1</sup> must not only satisfy our biological needs, respond appropriately to climate and site, and engender good mood and feelings, but also promote within a building's occupants, a feeling of inspiration and of listening to the environment. For children, a “place of the soul” must also be a place they can experience through playful exploration.

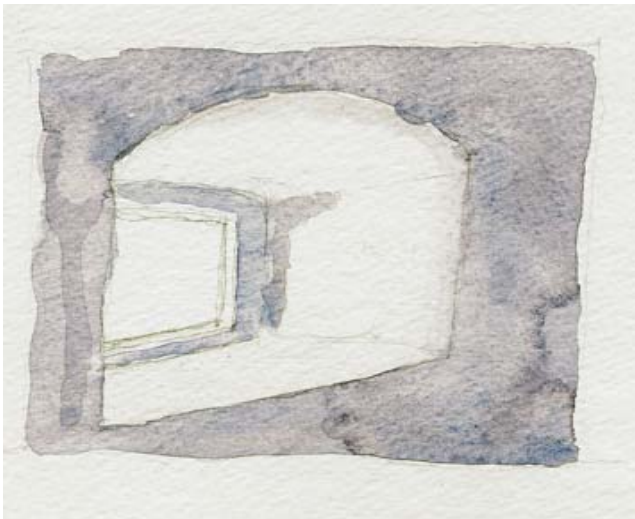


Figure 1 A deep window softens the light. Watercolor. Stratton Treadway, 2008.

---

<sup>1</sup> Places of the Soul.



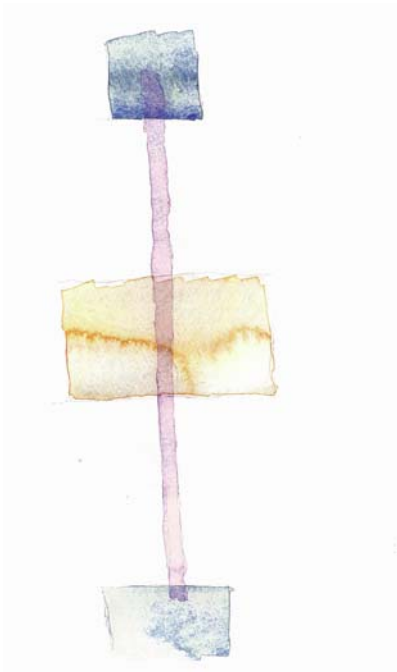
**Figure 2 A chapel space buffers light in a similar way. Watercolor. Stratton Treadway, 2008.**

Day goes on to explore specific ideas of the kinds of spaces that promote well-being and healing: a building sited in the landscape rather than plopped on top, a path curved to allow meandering (Figure 3) and to provide an oblique view upon approach rather than an axial directional path (Figure 4 below), thick walls with deep windows to soften the light coming into a room and to allow transitional zone from inside to outside. A child sitting in a window seat can see out, but remain hidden, if she chooses (Figure 1).

Below is an exploration of types of paths one might take to reach (or not reach) one's destination. The last image (Figure 5) attempts to evoke the experience of walking along a solid wall within a cleft in the earth on one side and a pool with light reflecting off it on the right.



**Figure 3** A meander allows for pooling of energy and ebbing and flowing of activity with no particular goal. Watercolor. Stratton Treadway, 2008.



**Figure 4** An axial, directional path appears to have a more overt destination. Watercolor. Stratton Treadway, 2008.



**Figure 5 An exploration of light and shadow along a path within the earth and beside the water. Watercolor. Stratton Treadway, 2008.**

Gaston Bachelard<sup>2</sup> points out that our response to architecture is rooted in our subconscious intuitive self and in our childhood experiences of similar places. Places, even ones we come to for the first time, are filled with rich meaning and associations, because of our expectations based on previous experiences. An attic or garret has specific meaning to us because of its elevated location under the shelter of the roof. A cellar, similarly, has meaning for us – as a literal and metaphorical dark space – because of its position on the bottom level of a house. We descend into the earth when we go into the basement. We have ascended in the direction of the Heavens when we climb up under the eaves. Our immediate and intuitive responses to the built environment shape the experiences we have within those walls.

---

<sup>2</sup> The Poetics of Space.



Bachelard also writes an essay on shells. Specifically he talks about the defensive position a soft animal might take within the safety of a hard shell. From this place of safety, an animal might muster its energy to strike. Through watercolor and collage (Figures 6 and 7 below) the author explored the idea of a shell that might nurture its inhabitant.



**Figure 6 A shell protects the soft animal within. Watercolor. Stratton Treadway 2008.**



**Figure 7 How might a shell make a building? Collage. Stratton Treadway 2008.**

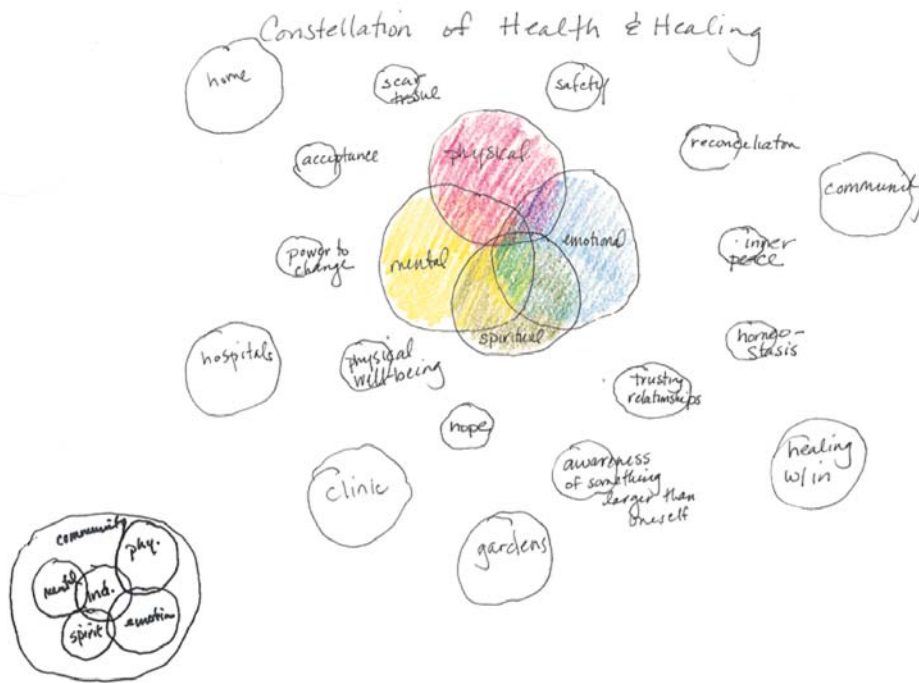
Children, especially those with special needs, are even more sensitive to experiences of space than adults – adults are bigger and can rationalize away feelings by recalling a wider range of experiences. Environments for children need to be sensitive to their heightened intuitive experience of space. This thesis will examine the ways in which children in general and children with certain cognitive and behavioral difficulties experience space in different or heightened ways from adults.



**Figure 8** Some children have physical and/or emotional scars. A scar can harden or diffuse over time. Watercolor. Stratton Treadway, 2008.



**Figure 9** A scar can be hidden or exposed. Collage. Stratton Treadway, 2008.



**Figure 10 Constellation of Health and Healing. Pen and Colored Pencil. Stratton Treadway, 2008.**

The above diagram (Figure 10) is a quick look at the ways in which healing – whether that be emotional, spiritual, mental, or physical -- can take place and in what setting it might take place. Above the diagram are images of scars as a manifestation of a past healing event. Old scars can diffuse back into the skin (or landscape) over time or they can remain red and angry (Figures 8 and 9).

## **Architectural Precedents of Poetry**

Interestingly enough, examples of healing architecture or architecture that seems to be responding closely to the needs of the human spirit, seems to be closely tied to the vernacular. Christopher Day describes vernacular architecture as “rich for the senses” and “warm ... for the soul.”(pg, 28, Soul) Its form materiality provides a user with a sense of well-being and connection with the historic and cultural landscape.

Luis Barragan, central-Mexican regionalist architect, uses simple volumes, thick walls, and the relationship between light and color to create mood and define space such as in the Convent at Tlalpan. The bright blue Mexican sky is a part of his composition and the “roof” to the private gardens he puts at the back of many of his houses. These gardens were designed as places of retreat and renewal. A thick concrete wall on the street side provides privacy to the family and makes the interior the focus of family life.

**Figure 11 Convent at Tlalpan. Martinez pg 110.**

**Figure 12 Casa Gilardi. Quiet Revolutionary, pg 237. And Casa Galvez QR, pg 131.**

Charles Rennie Mackintosh uses an architecture of thick walls and thresholds with lots of nooks in bedrooms as transition zones between outside and inside. These zones provide places to rest and watch either the activity in the room or the activity outside.

**Figure 13 Hill House interior with nooks. (internet)**

## **Poetic Building Types and Forms**

**Schools:** This thesis explores the rituals of learning in a child-centered place. Schools must balance the mundane issues -- limited points of entry and service entrances – with poetry that inspires and encourages learning. For many children, school is where they spend most of their time awake and, as such, becomes an intellectual home where many values are instilled and habits are ingrained.

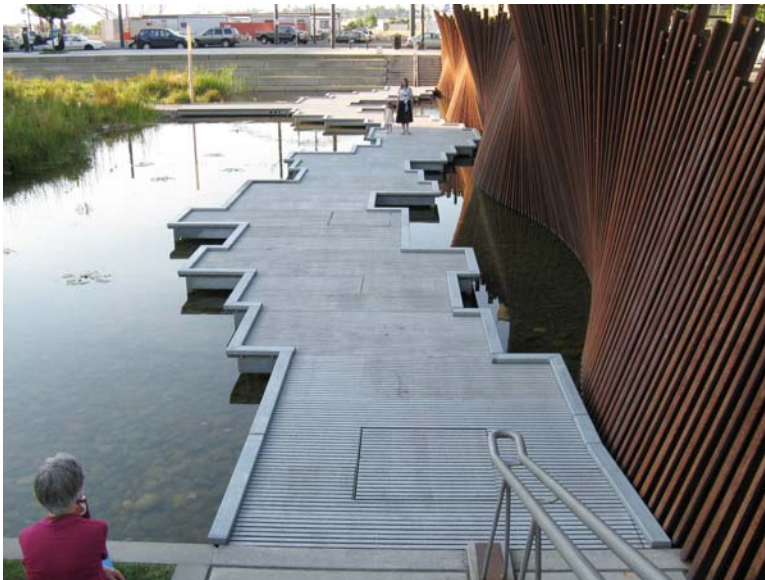
Crow Island School (Winnetka, Illinois), designed by Eliel Saarinen in 1939, is a place where pedagogy and its relationship to the great outdoors is explored architecturally. This school challenged notions of school design at the time – creating L-shaped classrooms that each had access to the great outdoors. The school will be diagrammed programmatically later in this document.

**Figure 14** <http://rogershepherd.com/WIW/solution5/crow2.html>

**Figure 15** <http://rogersshepherd.com/WIW/solution5/crow2.html>

**Gardens:** Follies. Footpaths. Element of Water. Sunlight and Shade. The smell of flowers like the orange blossoms in La Generalife in Granada Spain.

Tappen Springs Park in Portland, Oregon is a reclaimed wetland in a former city block. The city is quiet here and the natural world speaks in the silence. Crickets chirp; ducks and fish splash; the water has a sound and a silence all its own.



**Figure 16** Tappen Springs Park in Portland Oregon. The undulating, corrugated wall, buffers city noises. Stratton Treadway. June 2008.

Japanese gardens provide a precedent for the careful and intentional inclusion of the natural elements of wood, water and earth (stone) in a garden landscape. The ideas of harmony and balance also merit exploration.

**Figure 17**

[http://www.mobot.org/press/Media\\_Room\\_Images/Garden\\_Spring/downloadable/JapaneseGarden\\_JJennin gs.jpg](http://www.mobot.org/press/Media_Room_Images/Garden_Spring/downloadable/JapaneseGarden_JJennin gs.jpg)

**Play spaces.** In post-war Amsterdam, Aldo van Eyck developed a new paradigm for play in the city, putting play equipment for children into interstitial spaces where houses had once stood or on previously unoccupied urban corners. For the first time, play was available for all children in the city, not just those whose parents could afford to belong to private parks. With a simple language of play apparatus, he created environments where children were the moving parts. Spraying water, sand pits, and climbing apparatus were some of the elements with which and upon which the children played.



**Figure 18 Plan of van Eyck playground showing paving pattern, round sand pit and the location of other apparatus. (Internet)**

**Figure 19 Aerial view of van Eyck playground showing the crowd in the sand pit. Notice how the climbing apparatus (in lower portion of image) creates a sort of fence between the play space and the street. (Internet)**

### Chapter 3: Children and the Importance of Play

Last Child in the Woods and Geography of Childhood point us towards research demonstrating the effect of nature on the mood and behavior of all human animals. Children are calmed and inspired by experiences of the natural world. Research shows that children with Attention Deficit Hyperactivity Disorder (ADHD) or issues related to sensory integration (Rough clothing or crunchy food REALLY bothers them.) are calmed and engaged by being in nature.<sup>3</sup> Children who can see a tree out their classroom window feel better and are able to focus more on their schoolwork.<sup>4</sup>



**Figure 20** The author's nephew squeezes into a tight space. Stratton Treadway 2007.

Children's play is enriched by having varied environments that allow them to explore their surroundings. The simple act of being able to manipulate aspects of their environment can provide hours of enjoyment and discovery -- just think of a child with a stick, a bucket, a box of sand and some water. Architectural elements can be simple but they should be able to be used and enjoyed in multiple ways. Having play props that are a “loose fit” –they can be used in multiple ways without being prescriptive – is an essential element of play.

A child-centered environment must include places for children to hold themselves apart from play as well as opportunities for them to join play in progress. Sheltered spots sized for small people are important for children deciding if they want to join play.

---

<sup>3</sup> Last Child in the Woods.

<sup>4</sup> Last Child in the Woods.

Places for quiet play are just as important as places for group or active play.<sup>5</sup>

M. Paul Friedberg in Play/Interplay describes the value of what he called “linked play” where children can move naturally from one activity to another without having to stop in the middle of a sea of asphalt to decide which far-off piece of isolated play equipment they are going to play on next. Friedberg also points out that play is much richer than recreation alone. The best kinds of play allow for the voluntary mixing of ages of children and adults with activities that delight them all individually or collectively.

**Figure 21 These boys have options for climbing, running and jumping. Friedberg, Play/Interplay.**

This thesis explores the healing and learning potential of play and propose an architecture and landscape that will promote rich opportunities for play for preschool-age children. Architectural elements and environments proposed by Day, Friedberg, and van Eyck will be examined.

---

<sup>5</sup> Day advocates this in *Environment and Children: Passive Lessons from the Everyday Environment* (2007).

## **The Creative Curriculum System by Teaching Strategies, Inc.: Learning Through Play**

The Creative Curriculum was developed by Teaching Strategies based on current knowledge of child development and scientific research on how children learn. The program is successful for children with special needs and typically developing children so it is a good program for an inclusive classroom. The Teaching Strategies experts – classroom teachers, childhood educators and developmental psychologists -- cite the following theorists and ideas as the basis for the Curriculum:

- Abraham Maslow--Basic needs and learning
- Erik Erikson--The emotions and learning
- Jean Piaget--Logical thinking and reasoning
- Lev Vygotsky--Social interaction and learning
- Howard Gardner--Multiple intelligences
- Sara Smilansky--Play and learning
- Research on learning and resiliency
- Research on learning and the brain<sup>6</sup>

The developmental theory is applied to eleven areas of the classroom devoted to play:

- Blocks
- Dramatic play
- Toys and games
- Art
- Library
- Discovery
- Sand and water
- Music and movement
- Cooking
- Computers
- Outdoors<sup>7</sup>

---

<sup>6</sup> Teaching Strategies Website, 2008.

<sup>7</sup> Teaching Strategies Website, 2008

## Chapter 4: People as Program

Emotionally fragile and behaviorally difficult children are at a crossroads. If they are not offered a firm but supportive environment early in their development, their entry into mainstream society becomes more and more difficult with each passing year.

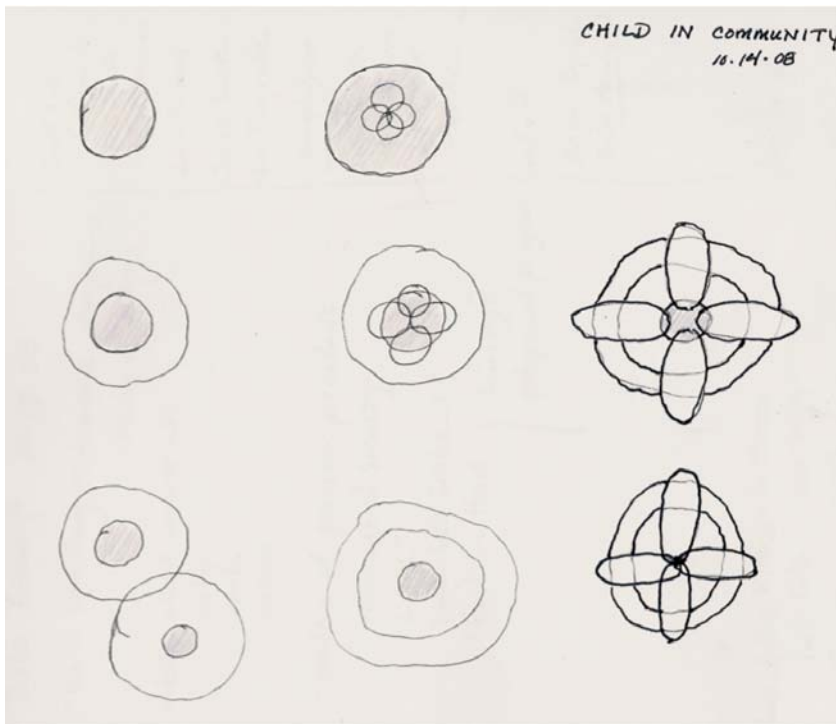
Children understand whether or not they are valued. If they attend a rundown school with water pooled on the floor during rainstorms, with broken play equipment, and not enough chairs -- or teachers! -- they will internalize the message that they do not matter much. Jonathan Kozol documents this tragic waste of possibility in his book Savage Inequalities (1991) in which he documents the imbalance of resources for poor and rich children in New York schools.

If a child is shuttled from home to home (such as the worst examples of the foster care system), she will eventually lose trust in fundamental loving human relationships and become unable to form them with others. Each early relationship and experience is magnified in importance for a child's healthy development.

In the series of early diagrams called “Child in Community” (Figure 22) the author thinks about the ways in which a healthy child is nestled within a family within a larger community and how that community also requires support from the larger community in order for it to remain healthy. The health of each layer of community impacts the health of the child and the family. For example, if a parent is unemployed, this brings a lot of additional stress into the family. If job losses mean that a lot of neighbors are also out of work, the whole community will be even more stressed. The same goes for someone getting sick without having health insurance and a community of people who as a rule do not have access to affordable health care. In Washington DC

there are, as of this writing, 13,000 children under the age of 2 and only 149 licensed spots for infants within the city and 4000 slots for children under two years of age.

Imagine the additional difficulty of finding child-care for a child with special needs.<sup>8</sup>



**Figure 22 Child in Community. Pen and Color Pencil. Stratton Treadway 2008.**

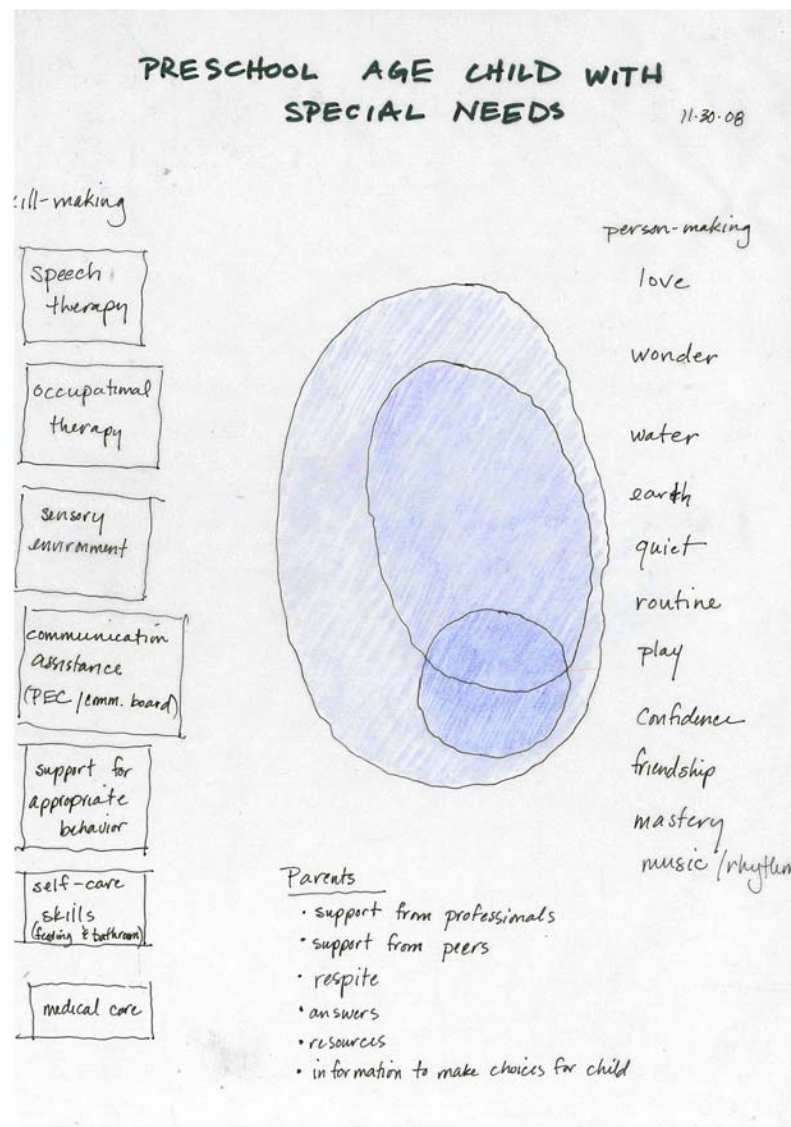
### **Nurturing Spaces for Children with Special Needs**

Children with autism, Downs Syndrome and other kinds of cognitive disorders often have specific and intense sensory needs. From several sources, the author knows anecdotally that children with autism are captivated and calmed by spinning objects – a ceiling fan, a spinning toy, themselves spinning in a swing. Similarly, children with

---

<sup>8</sup> WP (March 23, 2009) “NE Residents Protest Closure of DC Day-care Center.”

special needs often have sensory issues related to food or clothing. They might not like foods to touch. They may not like foods of a certain color, temperature or texture. Often they need professional assistance and encouragement to try new foods. These children, as well as their typically developing peers, need places to retreat when the environment gets over-stimulating. They need places to observe activities and choose whether to get involved or not.



**Figure 23** Early diagram about the kinds of support therapies a preschool age child with special needs might require. Pen and Color Pencil on Trace. Stratton Treadway 2008.



Figure 24 An early diagram showing the physical places in which healing might take place. Pen and Color Pencil on Trace. Stratton Treadway 2008.

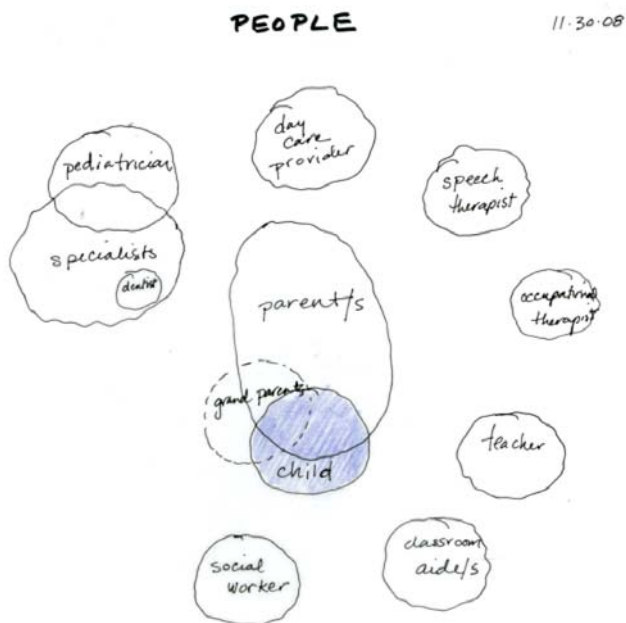


Figure 25 Early diagrams about people who support children with special needs. Pen and Color Pencil on Trace. Stratton Treadway 2008.



More practically, in the classroom, children with special needs may well need help going to the bathroom, washing hands, and feeding themselves for a longer time than their typically developing peers. The architecture must support this difference in ability while not making the children feel embarrassed. Indeed, rituals and routines which give all children a feeling of control over their day will be important to explore architecturally (Figure 26).

**DAILY PROGRAM BY RITUAL**  
(PRESCHOOL) 12.12.08

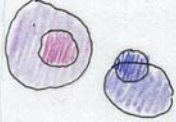

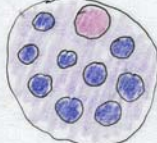
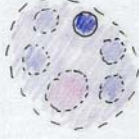
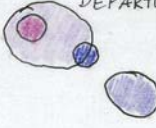
<b>MORNING</b>	<p>WELCOME</p> 	<ul style="list-style-type: none"> <li>greetings</li> <li>good byes</li> <li>hugs</li> <li>tears</li> <li>exchange of information</li> <li>coats off</li> </ul>	<ul style="list-style-type: none"> <li>parking / drop off</li> <li>front porch</li> <li>cubbies</li> <li>coats</li> <li>objects from home</li> </ul>
	<p>CIRCLE TIME</p> 	<ul style="list-style-type: none"> <li>sharing songs, stories</li> <li>listening</li> <li>individual performance</li> <li>corporate activities (working together)</li> </ul>	<ul style="list-style-type: none"> <li>carpet</li> <li>teacher's spot / speaker</li> <li>place for props</li> <li>rocking chairs</li> <li>case</li> </ul>
	<p>MEALTIME</p> 	<ul style="list-style-type: none"> <li>washing hands &amp; toilet (or diaper)</li> <li>preparing food</li> <li>delivering food</li> <li>trading food</li> <li>eating &amp; drinking</li> <li>cleaning up</li> <li>sensory therapy</li> </ul>	<ul style="list-style-type: none"> <li>bathroom</li> <li>changing table</li> <li>sinks</li> <li>kitchen</li> <li>counter</li> <li>tables &amp; chairs</li> <li>waiting area</li> <li>trash disposal</li> </ul>
<b>AFTERNOON</b>	<p>NAP</p> 	<ul style="list-style-type: none"> <li>setting up beds</li> <li>transition to rest or sleep</li> <li>story time</li> <li>nap</li> <li>transition out of sleep</li> <li>putting beds away</li> </ul>	<ul style="list-style-type: none"> <li>cot storage</li> <li>cots (set out)</li> <li>place for nappers</li> <li>place for non-nappers</li> <li>place for teacher(s)</li> </ul>
	<p>DEPARTURE</p> 	<ul style="list-style-type: none"> <li>greetings</li> <li>hugs</li> <li>good byes</li> <li>exchange of info.</li> <li>coats on</li> </ul>	<ul style="list-style-type: none"> <li>parking</li> <li>front porch</li> <li>cubbies</li> <li>coats</li> <li>objects to take home</li> </ul>

Figure 26 Column two contains activities and column three, architectural elements. Pen and Color Pencil on Trace. Stratton Treadway 2008.

## **Proposed Program**

The proposed architectural program is a Child Development Center, modeled on the Easter Seals program in the Washington DC Metro Area. Fifty-six children can be accommodated – twelve children in each classroom and eight infants in the nursery. In addition to daycare or preschool, the majority of the therapeutic needs of the children would be accommodated on site. Families would be connected to a wider web of resources through programs available on site (a dentist and certified nurse practitioner) and a social worker who can connect them to other private and public programs such as food stamps and children’s health insurance. The goal of the program would be to prepare all of its graduates for a successful primary school experience.

The center would use a model of inclusion – children with diagnosed special needs would be in the same classroom with their typically developing peers. The goal would be to accommodate 25% of children with special needs and 75% “typically developing” children as the precedent Easter Seals program does (described below). The typically developing children and their peers will likely not look or act too much different from each other. But the needs of all children will be met by the teachers, aides and therapists in a mixed-diagnosis, mixed-ability classroom.<sup>9</sup>

In order to bring in other community members who might participate in the nurturing and support of the children, the program calls for a Senior Games Room and a small Library. Finally, the architectural program integrates a significant outdoor space for children and adults to accommodate teaching, play, and experiences of the out-of-doors.

---

<sup>9</sup>All children with special needs who can be cared for with a child to adult ratio of 3:1 are accommodated by the Easter Seals program. Children who require more care (1:1) can attend the program, but would need to have an additional aide with them.

## Tabulated Program Requirements for a Child Development Center

	Description	Quantity	SF	Total SF
<b>Entry/Reception/ Public</b>				
	Reception	1	100	100
Caregivers' Resource Room	Drop-in Center for parents staffed by social worker	1	200	200
Restrooms for Adults	Off of public space.	2	200	400
Gathering Space/Piazza	Transition zone for mornings and afternoons. Can it be used for performances? Classrooms should be off this space.		2000	2000
<b>Child Development Center</b>				
Infant care (8 infants)	Eight infants cared for in two spaces -- one for sleeping and one for activity. (30sf per crib). Must exit directly to outdoors.	1	800	800
Classrooms (12 students)	Blocks area, art/mess area/ quiet place apart from main space, space for group activities. Bathroom attached to classroom. Teacher must have lockable work station and collaborative space. Sinks located in mess areas and outside of bathroom.	4	1000	4000
Director's Office	Houses director with space for small meetings. Should be within sight of entrance.	1	300	300
Administrative Staff/ CDC Sign-in	Adjacent to Director's Office and front door.	1	200	200
Teacher Resource Room	Shared resources. Seasonal item storage. Rotating toys (to keep kids from getting bored.)	2	100	200
	Description	Quantity	SF	Total SF

Staff Break Room	Lunch and collaborative meetings.	1	160	160
Cafeteria	Separate from Gathering space. Separate Entrance would allow community to use after hours.		1200	1200
Commercial Kitchen/Prep Area		1	300	300
Laundry	Locate near infant and toddler rooms.	1	50	50
<b>Therapy Suite</b>		1	900	
Therapist Offices		3	144	432
Adaptive Technology Resource Room	Desk for visiting technology specialist. Storage area for a range of adaptive technology equipment.	1	200	200
Small Conference Room	Meetings with Families/ Collaboration	1	200	200
Ball Pit and Swing		2	50	100
<b>Community Resources</b>				
Community Health Suite	A suite to house a doctor and dentist whose services would be provided to children and their families. Own receptionist?	1	800	800
Community Kitchen	For children and adults to cook and eat. Locate near outdoor garden and eating space.	1	400	400
Senior Games Room		1	800	800
Library		1	800	800
<b>Building Subtotal</b>				<b>13642</b>
<b>Core</b>				

Mechanical	10%	1360
Elevator Core	if needed	
Circulation	15%	2050
<b>Building Total</b>		<b>17052</b>
 <b>Outdoor Space</b>		
Children's Play Space	as needed	
Garden	as needed	
Parking and Drop Off	For staff, parents and visitors.	
Service Trash Pick-up		

There are other ways of thinking about program. One way to assess program might describe important daily rituals, the activities and actors involved in the rituals and the architecture needed to accommodate them. (Figure 26 above) Another might investigate the experiences of the five senses. Another way, as encouraged by Christopher Day might be to make sure that the architecture accommodates the need for children to be in touch each day with the four essential elements of fire, water, earth and air. The following diagram (Figure 27) describes the essential qualities of the element, in what form it might be experienced, what activities children might engage in around the element, and what kinds of architecture might facilitate its inclusion into the school environment.

# PROGRAM BY ELEMENT

(Suggested by Christopher Day)

12.12.08

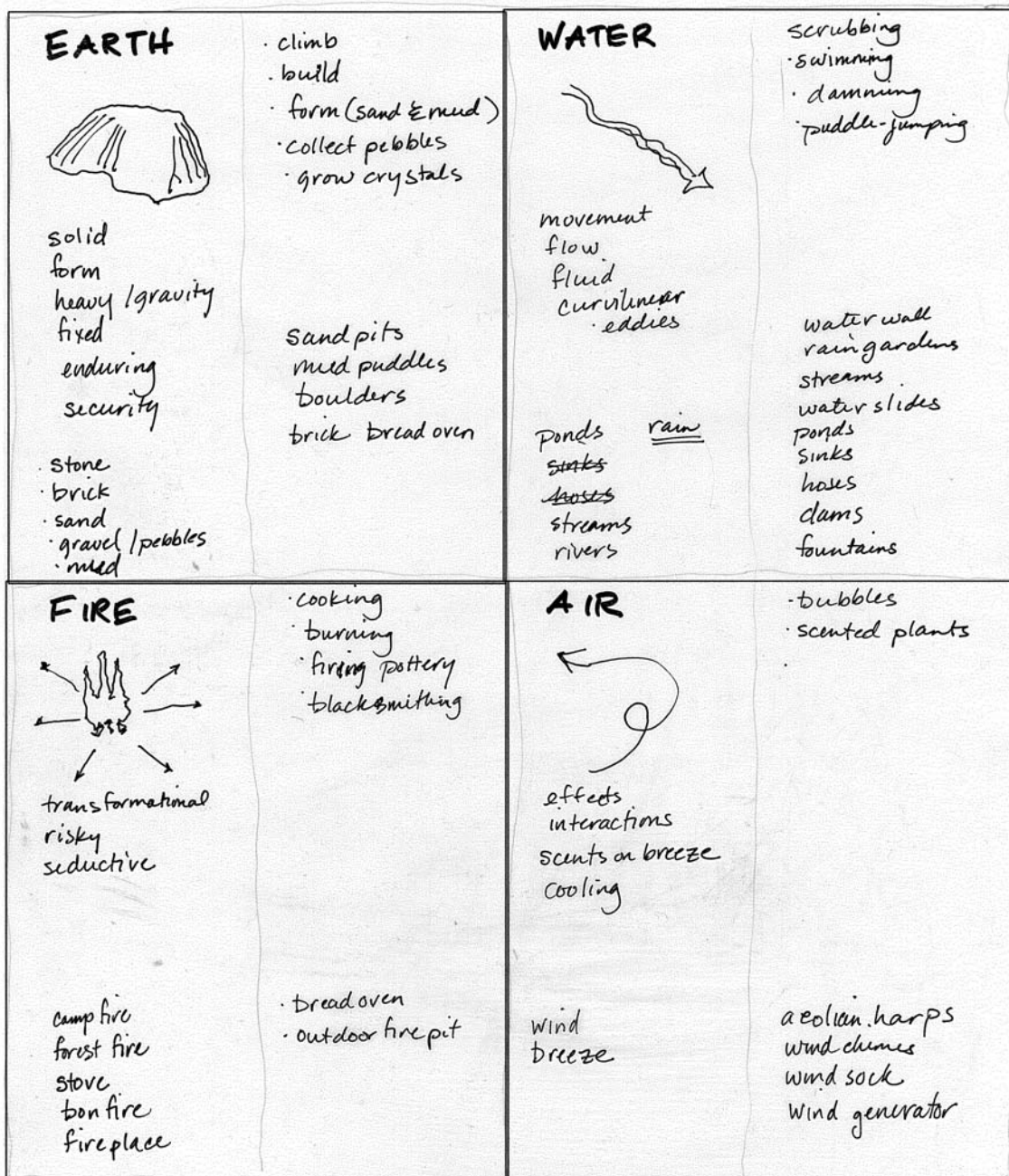


Figure 27 Diagram of ideas from Christopher Day incorporating the four elements into a learning and play environment for children. Stratton Treadway 2008.

## **Program Precedents**

There are a number of facilities in the Washington DC Metro Area which already seek to accommodate pre-school age children with special needs in an inclusive and supportive environment. The author has visited several such programs in the area and the following precedent studies are based on her interviews, observations and analysis.

### **Program Precedent: Easter Seals**

Easter Seals operates four Child Development Centers in the Washington DC metro area. The program serves children from six weeks up to five years of age. Each center strives for a balance of 25% of children with special needs and 75% typically developing children. Because of the need for such programs, the center in the District of Columbia has 50% children with special needs and 50% typically developing children. The center, which has places for around 70 children from 5 weeks to five years in age, has a waiting list of 219 students. All children are in the classroom together and any needed therapies are incorporated into the classroom setting. The facility is open all day to accommodate working parents.

Each center provides a developmentally appropriate curriculum with an emphasis on individualized lesson plans. The *Creative Curriculum* (described earlier) is the basis for the early childhood education; play is the vehicle through which learning occurs. The goal is to have all children ready to enter a regular school at the completion of the program.

Each Child Development Center incorporates parent support and community education as part of their model. Respite programs and other support for families caring

for children or adults with disabilities are also provided. The Harry and Jeanette Weinberg Inter-Generational Center in Silver Spring also incorporates an adult day care which provides medical, rehabilitative, recreational and educational services to adults and seniors with a variety of disabilities. Adults as well as children are assessed and referred to the program by outside social service or medical professionals. The typically developing children are accepted by application on a first-come, first-serve basis.

Adults and children at the intergenerational center are matched and participate in carefully planned, regularly scheduled intergenerational activities. Meals and snacks are often shared between the generations. Both the adults and the children benefit from intergenerational activities through enhanced social skills, improved physical health, and better cognitive functioning.<sup>10</sup>



**Figure 28 Plan diagram showing overall divisions of space. Stratton Treadway 2009.**

The plan of the Weinberg Center carefully segregates entry to the children's classroom area (Figure 28, yellow) with a staffed check-in desk behind a door. Shared

---

<sup>10</sup> Easter Seals literature, November 2008.

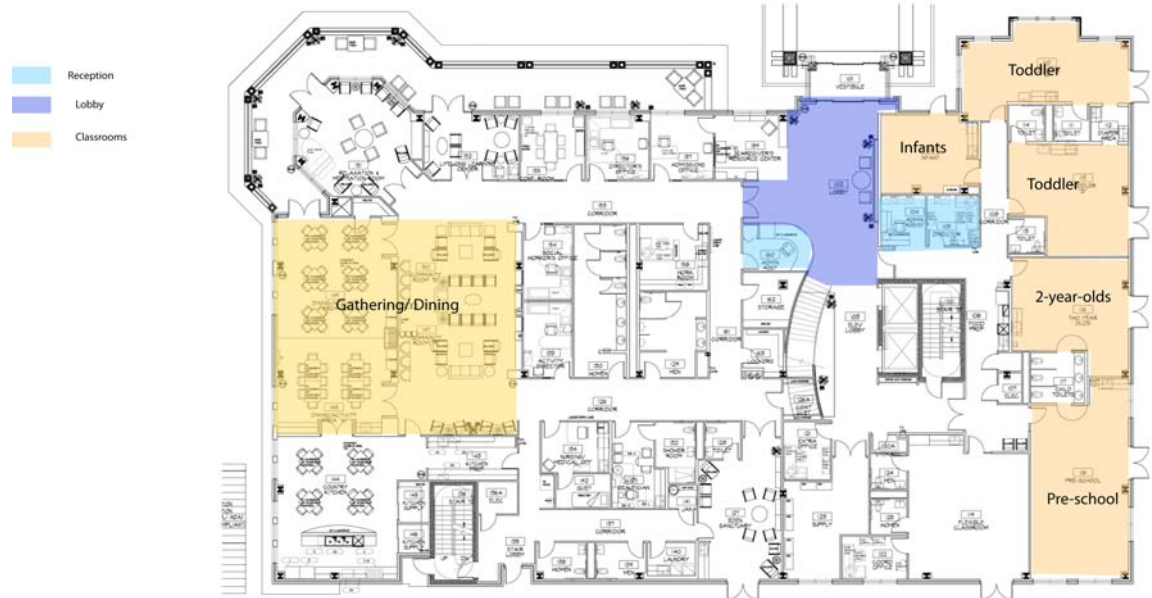


support services (Figure 28, aqua) such as bathrooms, a rehabilitative beauty shop and other therapy rooms for adults are located in the center of the plan. A caregiver's resource room is located near the entrance to the building. Program elements to the left (Figure 28, purple) are for adults or intergenerational activities. Meals can be shared in the dining/activities room. The large open space is used for story-telling and singing but it is located outside the secure area of the Child Development Center (Figure 30). Teachers must plan ahead to use this space, reducing its utility for spontaneous events or projects. Naturally, though, there are legitimate security, privacy and noise issues that must be addressed.

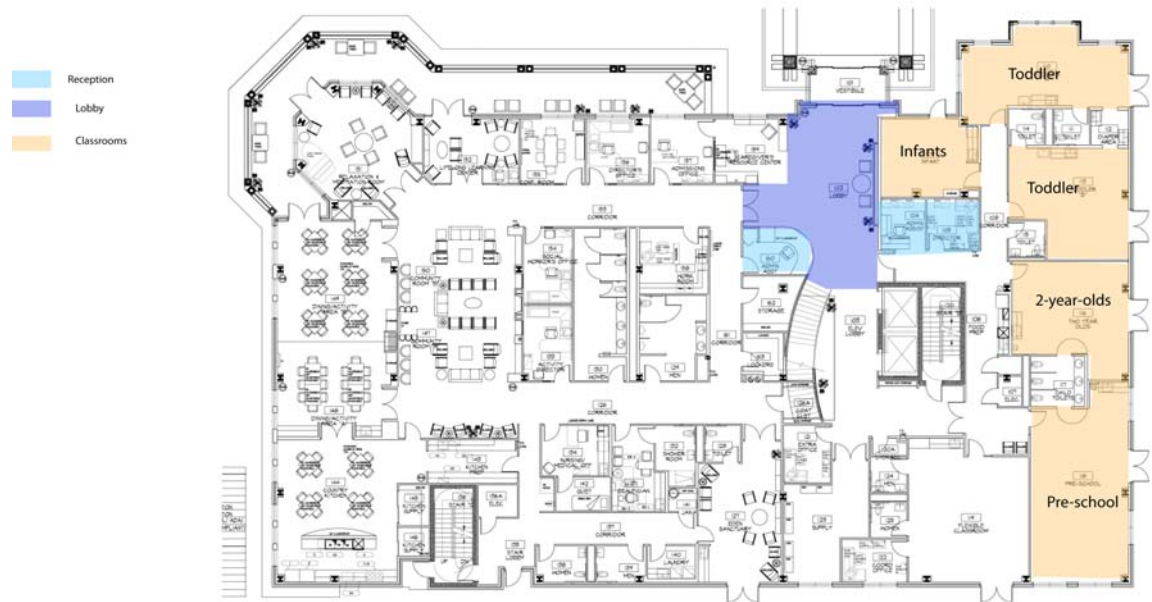


**Figure 29** The great room for intergenerational activities. Photo Stratton Treadway November 2008.

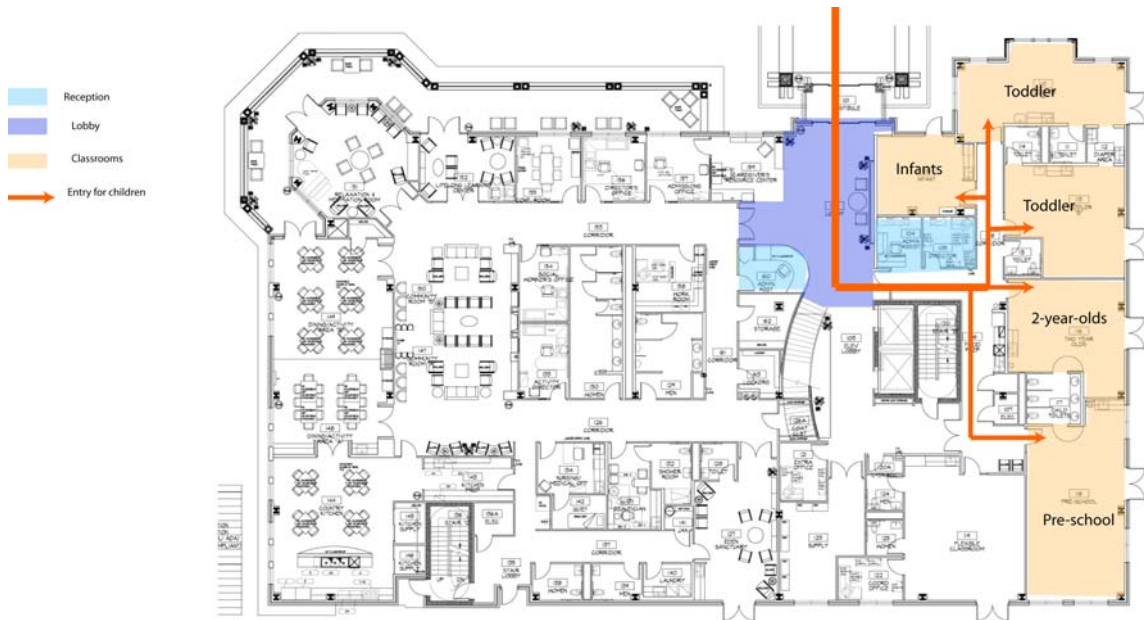
Classrooms, which meet Montgomery County standards, are too small to accommodate any gatherings of more than one class or any large projects. (Figure 31) The classrooms range from 350-800sf.



**Figure 30** Gathering and dining spaces are located pretty far away from the children's classrooms. Stratton Treadway 2009.



**Figure 31** Classroom configuration showing main lobby and reception desk and check-in desk for Child Development Center. Stratton Treadway 2009.



**Figure 32** How children enter their classrooms and pass by the check-in desk. Stratton Treadway 2009.



**Figure 33** A preschool classroom with cots, a perch and a place to be quiet underneath but not room for making more than one mess. Stratton Treadway 2008.

All classrooms have a door to the outdoor space -- which has a rubberized surface. Unfortunately, because of site limitations, the outdoor space at this facility is

limited to a narrow band to the bottom and right side of the plan as it is oriented here.

(Figure 34) The playground equipment is specifically designed to meet the play needs of children with special needs. Children in wheelchairs can reach every activity. (Figures 35, 36, 37).



**Figure 34 Access to rubberized outdoor area from each classroom. Stratton Treadway 2009.**



**Figure 35** A special "bowl" to accommodate the spinning needs of autistic children (and many other children.) Made by Kompan. Stratton Treadway 2008.



**Figure 36** A water and sand table at wheelchair height. Made by Kompan. Note the narrowness of the outdoor space. Stratton Treadway 2008.



**Figure 37** Sensory bumps and spinning wheels to accommodate sensory needs. Made by Kompan. Stratton Treadway 2008.

**Program Precedent: Longfellow Elementary School Classroom for Toddlers with Multiple Intense Needs.**

Longfellow Elementary School in Howard County (Columbia, MD) is a Title 1 school which means it has additional resources for caring for the needs of children with significant emotional and behavioral difficulties.<sup>11</sup> The author visited a large classroom for two and three year-olds in a cluster of classrooms for children with Multiple Intense Needs. One teacher and three aides work with eleven children in this classroom – at this time six are “typically developing” and five have some series of diagnoses. Again, though, the children are peers in the classroom and the activities are inclusive. Therapists come into the school to meet with children. The head teacher visits each child at home once a week during the afternoons.

Though the classroom was large (1000+sf), the layout had some short-comings. For example, there is only one sink in the room and each child has to be helped to reach it because the countertop is too deep for them to reach it on their own. Because the children must pass by the eating tables on the way to wash their hands, they are easily distracted. Mealtime takes longer and is more contentious because of this.

---

<sup>11</sup> Children who need walkers or wheelchairs are accommodated at another preschool program in the county.

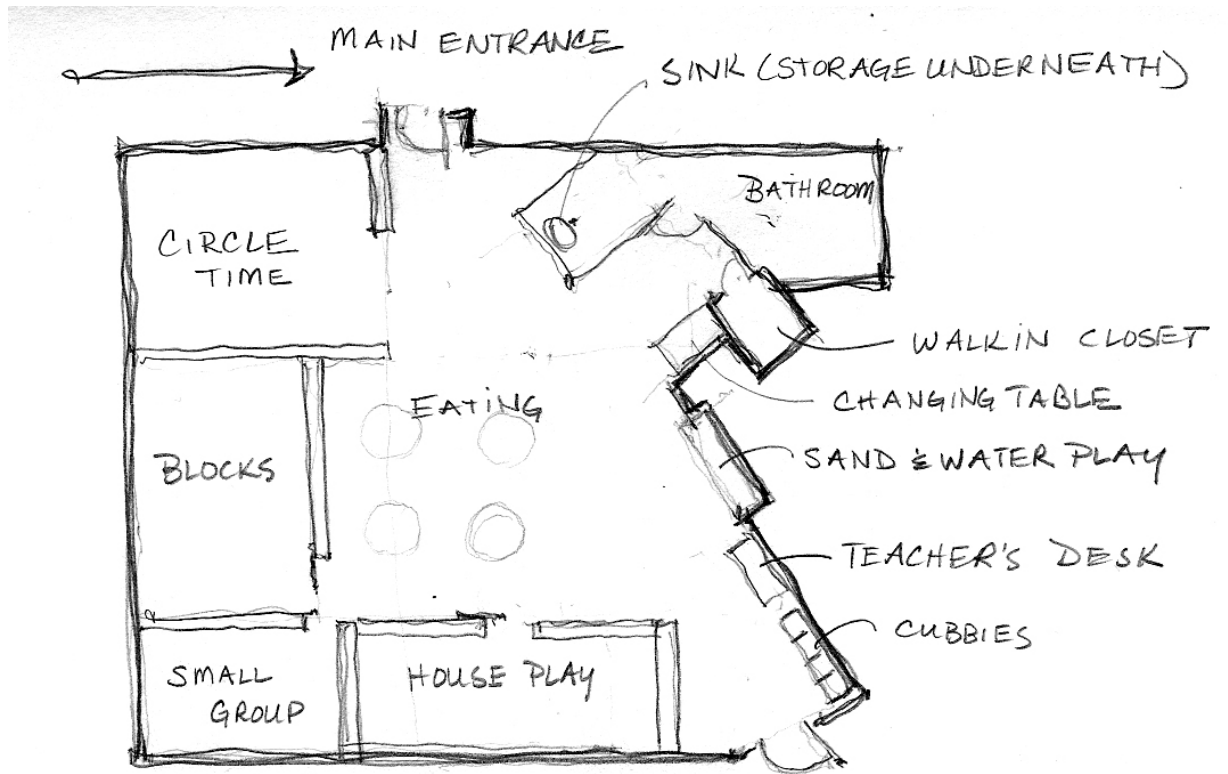


Figure 38 Overall plan of the classroom showing the gated activity areas and other spaces. Stratton Treadway 2009.



**Figure 39** View from the doorway close to the main entrance showing the overall layout of the classroom with its multiple gated activity areas and eating area in the center. The class schedule is on the back wall, big enough to be read across the room. Photo Stratton Treadway 2008.



**Figure 40** Circle time area has rocking chairs to accommodate children who can't sit "still" without being in motion. All children regardless of diagnosis can use the rockers. The teacher leads songs and stories with about half the class at any one time Photo Stratton Treadway 2008





**Figure 41** A picture board indicates who is here today. Photo Stratton Treadway 2008.

Visiting this classroom, even though children were not present at the time, gave the author some idea of the rituals and routines important to the smooth running of the school day. (Figure 40 and 41) The teachers and children sing songs together at transition times – a greeting song in the morning, a washing hands song and a goodbye song. (Figure 42)



**Figure 42** A laminated sign reminds everyone to sing the hand-washing song. There is a song for getting through each routine. Photo Stratton Treadway 2008



**Figure 43** Bumpy, shiny boards in the block area accommodate the need for some children for sensory stimulation. The small holes in the pegboard also accommodate this need. Photo Stratton Treadway 2008



**Figure 44 Non verbal children must ask permission with a picture to have the gate opened. The teacher has cut down the gate herself for her small pupils. Photo Stratton Treadway 2008**

Many of the rituals instituted by this classroom teacher for her toddlers will be important to accommodate in a Child Development Center (See Figure 26). Also, the solutions she has pieced together to accommodate the small size or multiple needs of her charges (like cutting and taping the gate (Figure 44) and placing oilcloth over distracting surfaces) are important practical design lessons.

## Program Precedents: Architectural

Several architectural precedents were examined for ideas about classroom size, relationship of classrooms to the entrance of the building and to the outdoors. The relative size of other spaces was also examined.

### Crow Island School, Winnetka, Illinois

The Crow Island School was designed by Eliel Saarinen in 1939. As stated earlier, the school is known for its innovative L-shaped classrooms and by the relationship each classroom has to the outdoors (Figure 45).

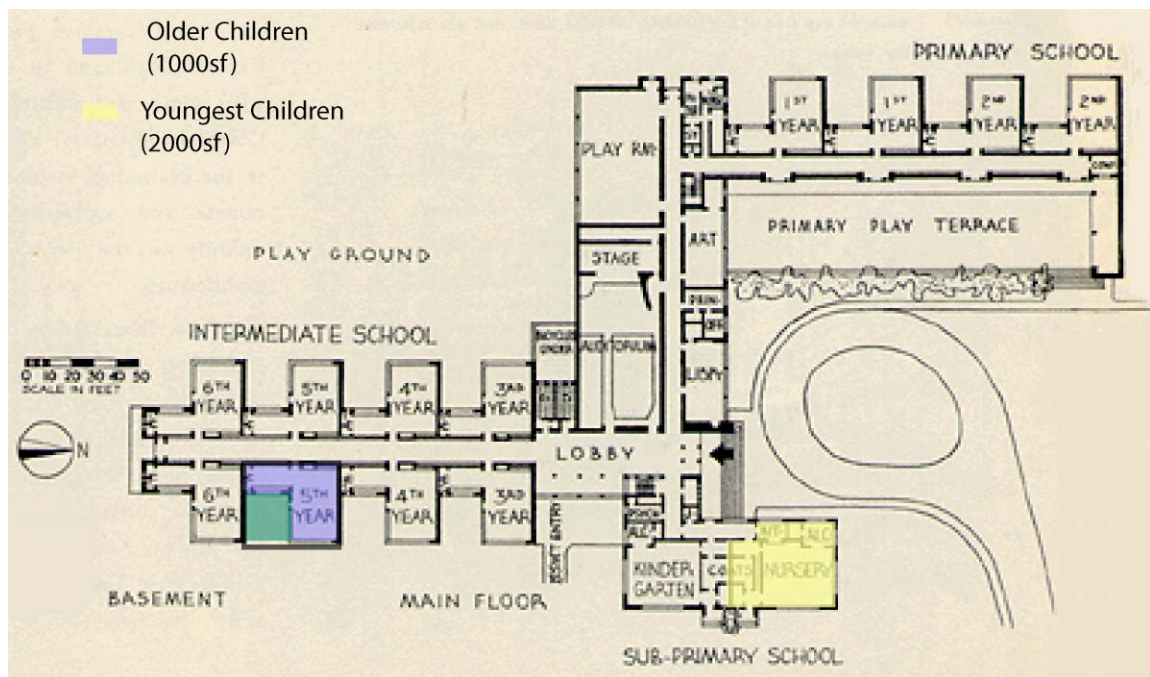


Figure 45 Plan showing L-shaped classroom for older children and a typical classroom for the younger children. Stratton Treadway 2009.

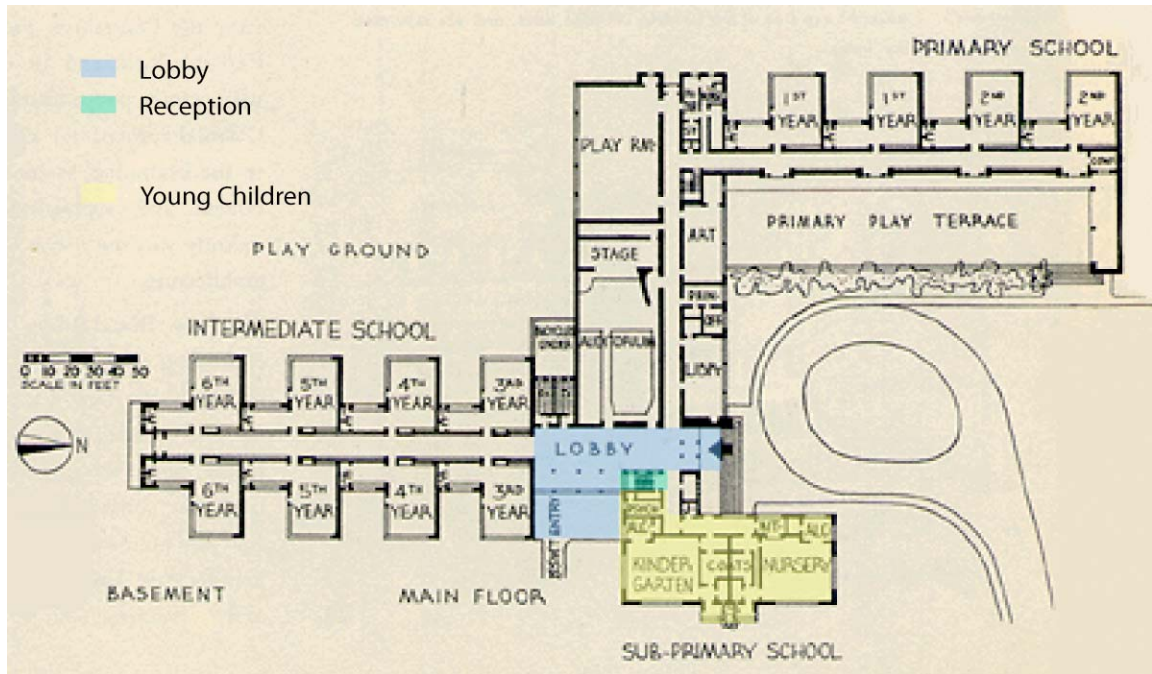


Figure 46 Relationship between the classrooms for young children and the lobby and reception area. Stratton Treadway 2009.

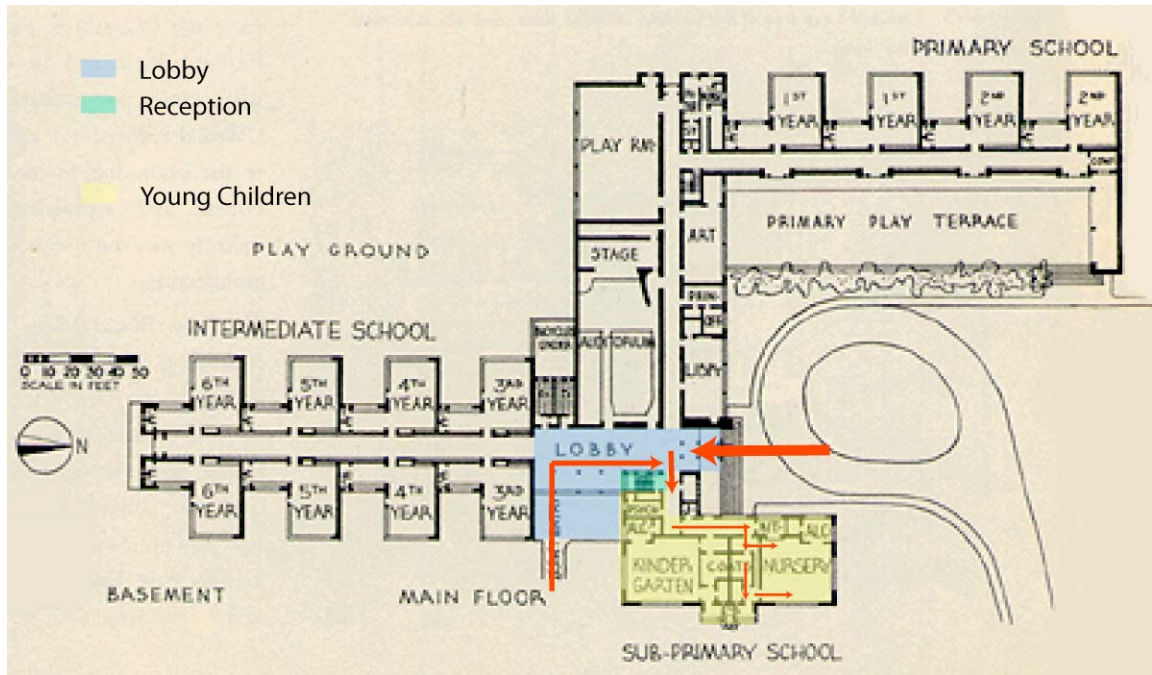


Figure 47 Young Children must pass the reception desk to get to their protected wing of the building. Stratton Treadway 2009.

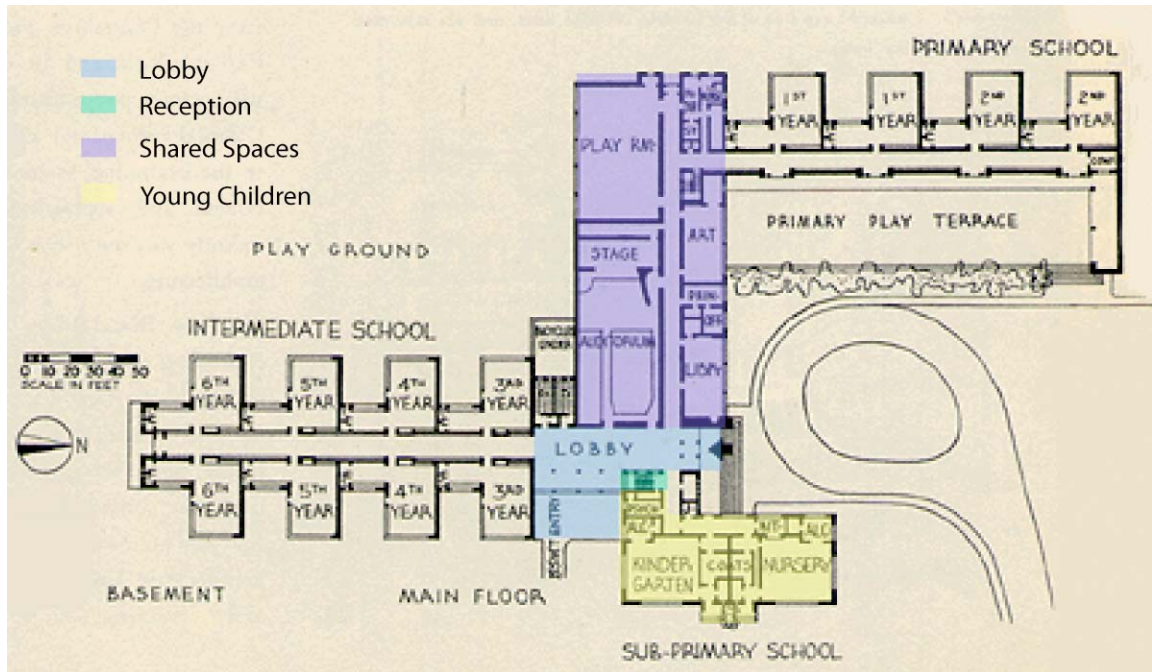


Figure 48 The relationship of the children's wing to the shared resources of the school – art room, library, play room and auditorium. Stratton Treadway 2009.

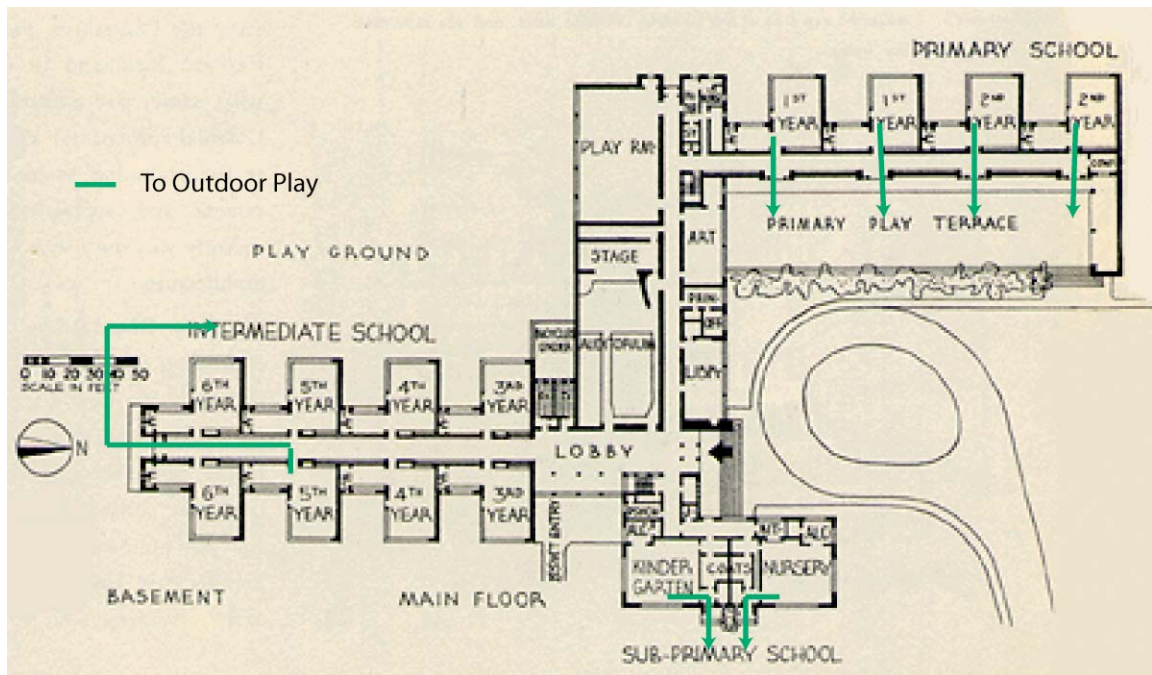


Figure 49 The younger the child the closer their classroom is to their outdoor play space. Stratton Treadway 2009.



**Figure 50** Google Maps site photo showing the outdoor spaces associated with the classrooms and classroom wings. Diagram by Stratton Treadway 2009.

## Asilo Infantile Sant'Elia, Como, 1936-'37

Designed by Giuseppe Terragni, noted Italian Rationalist architect, the Asilo Sant'Elia, is most widely known for its formal architectural characteristics. But there are also lessons to be learned by studying its functions and their relationship to one another and to the ways in which the architecture enhances the performance of school rituals.

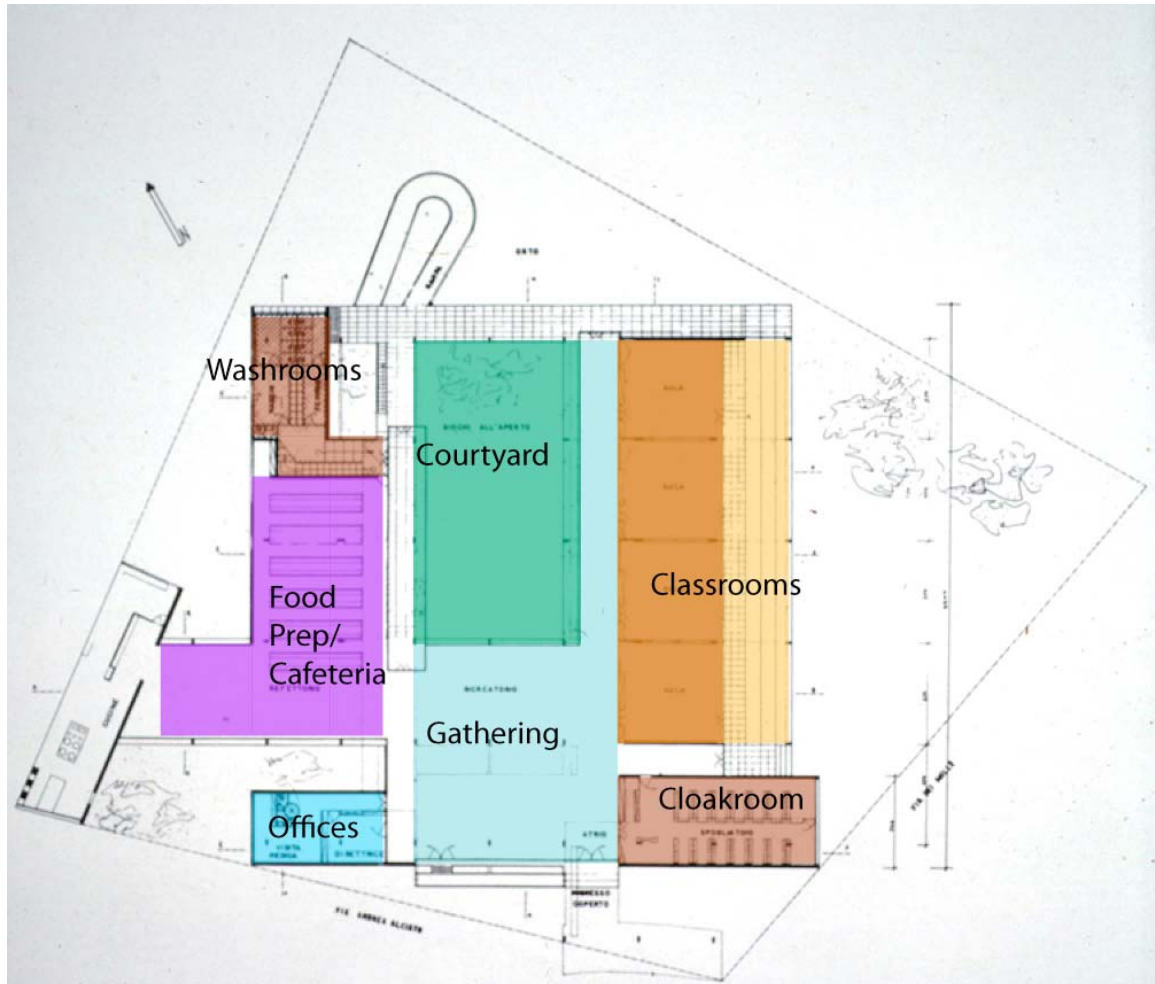
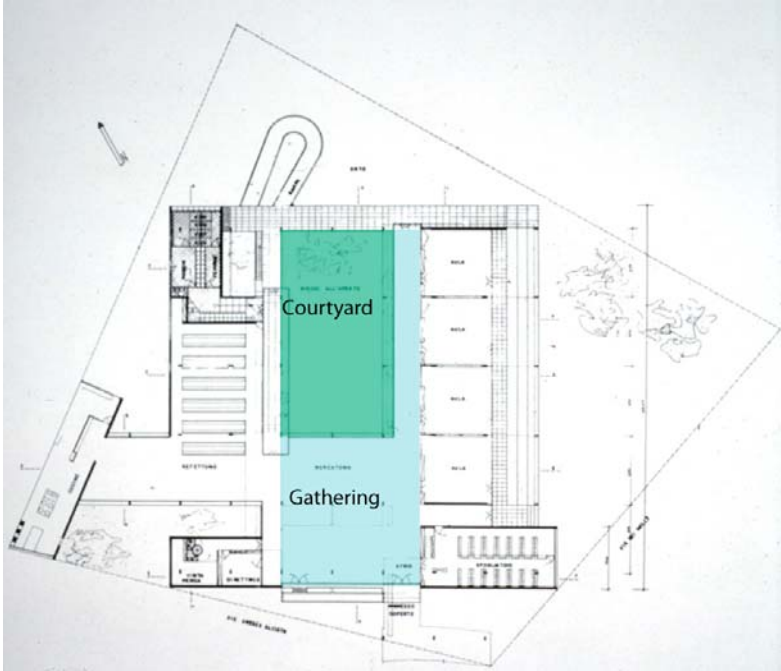
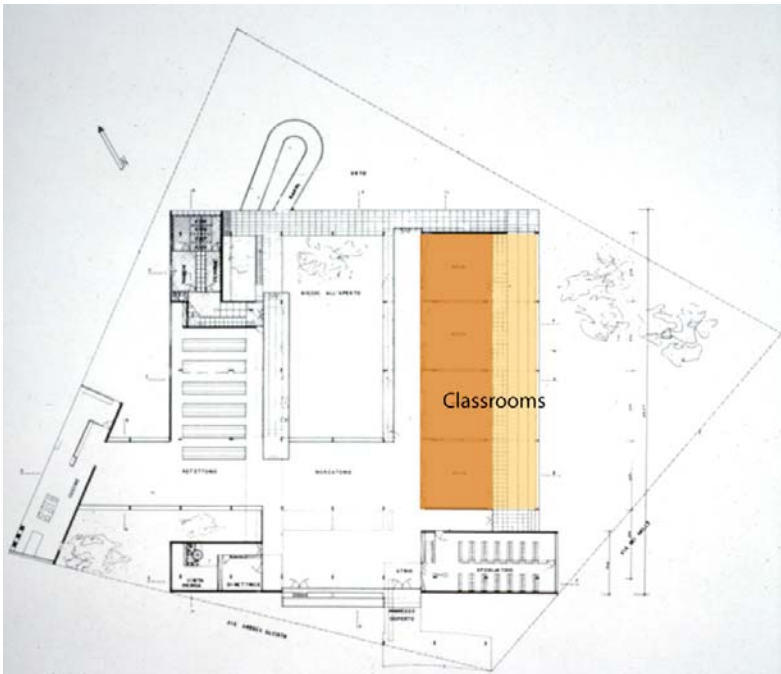


Figure 51 The Asilo includes large indoor spaces for gathering and for eating together. The offices are located near the front entrance. Stratton Treadway 2009.

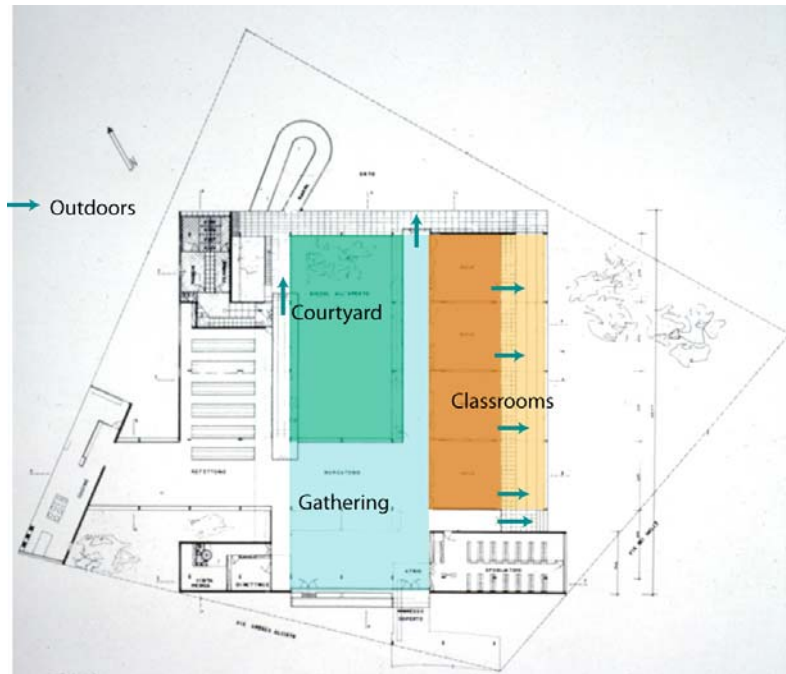




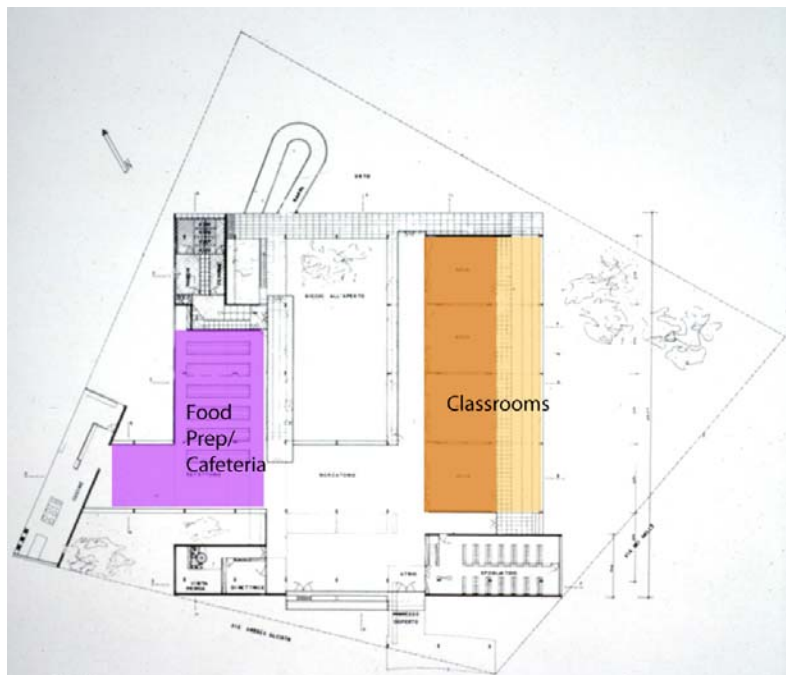
**Figure 52** The courtyard and its indoor extension form the heart of the building. Stratton Treadway 2009.



**Figure 53** The preschool contains four classrooms on the southern side of the building. Each classroom has an outdoor extension (lighter orange). Stratton Treadway 2009.

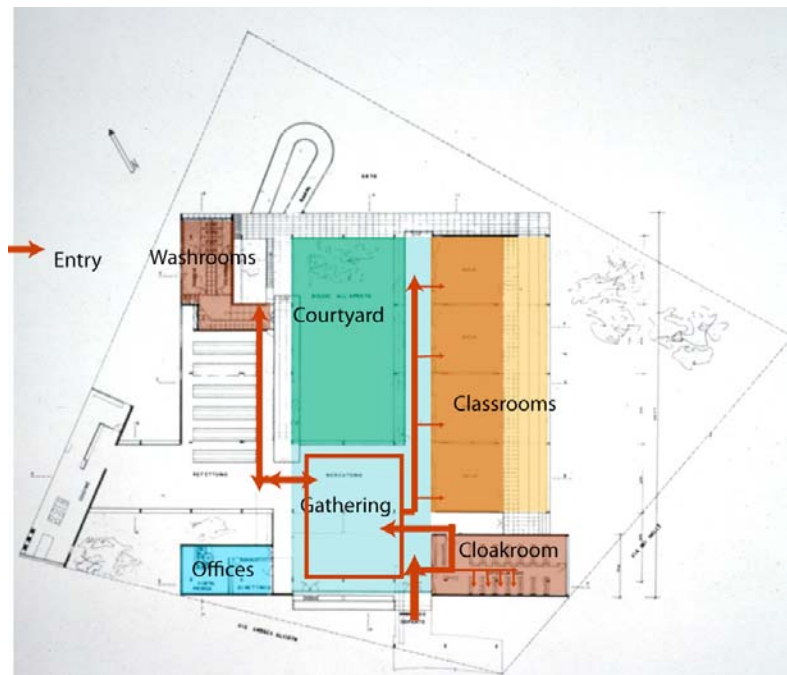


**Figure 54** Each classroom has direct access to the out-of-doors. To get to the courtyard, one has to go through a hallway. Stratton Treadway 2009.

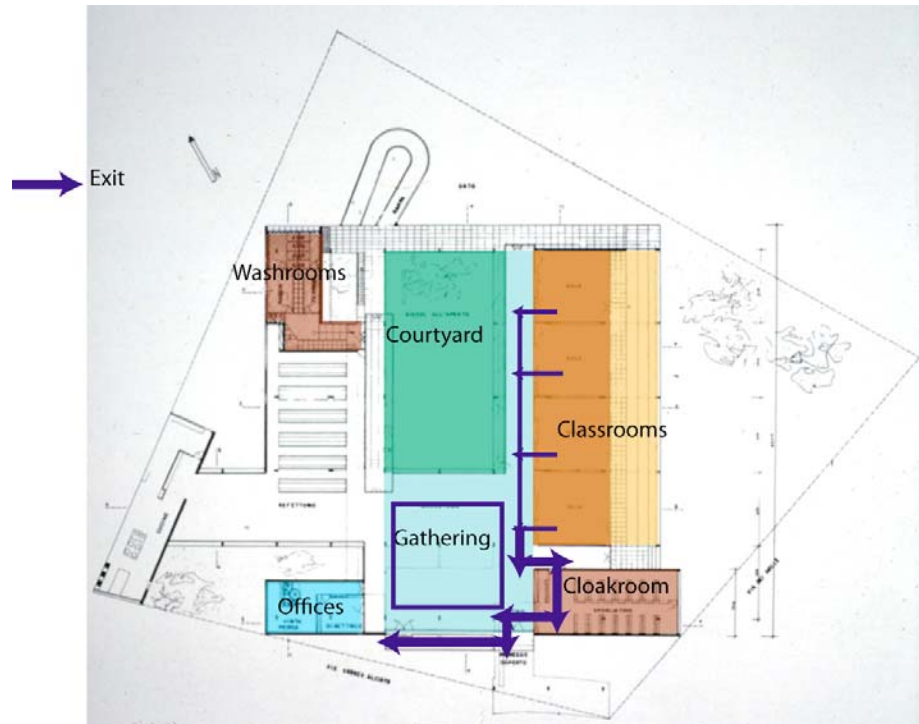


**Figure 55** Children cross the gathering space to reach the cafeteria where they eat together – an important community socialization ritual. Stratton Treadway 2009.

In the Fascist Era when the preschool was built, ritual and the socialization of children was very important. So was hygiene. The morning ritual involved a trip to the cloakroom for each child, a trip to the washroom for a thorough washing and a morning meeting in the gathering space. Then the children dispersed to their classrooms. (Figure 56.) In the evening, children would collect their coats and wait for their parents on a porch outside. (Figure 57).



**Figure 56 The ritual of gathering in the morning. Stratton Treadway 2009.**



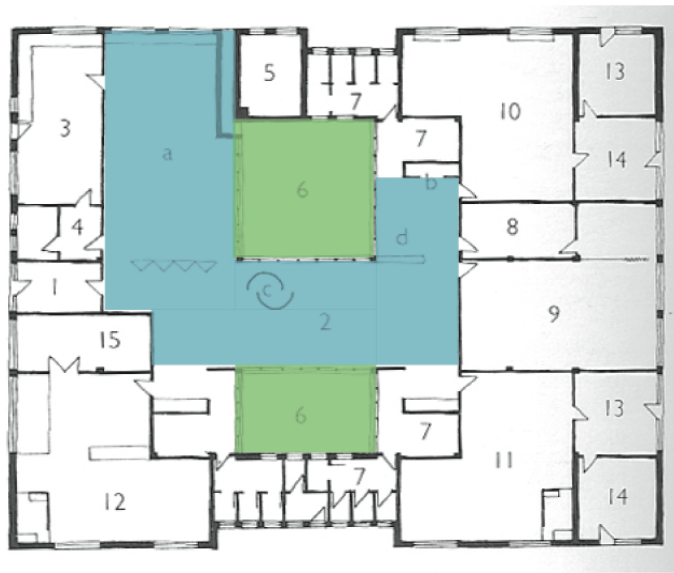
**Figure 57 The leaving ritual. Stratton Treadway 2009.**

### **The Diane School, Reggio Emilia, 1971 - ongoing.**

The Diane School is a preschool for 75 children from ages three to five years, in three age-segregated classrooms. Architecturally, the building is a modest form, but its interior spaces reflect the complicated form of the community within. An irregularly-shaped interior piazza linked with a pair of courtyards, forms the heart of the building. (Figure 58) Within the piazza, the children gather, eat, perform puppet shows and do dress-up. Each classrooms with its attached activity areas and washroom (Figure 62) is around 2000sf and the entire building is 8600sf. The grounds are 17000sf.<sup>12</sup>

<sup>12</sup> Dudek, Mark. Kindergarten Architecture, pg. 200.

- Interior Courtyard
- Piazza/Gathering



**Figure 58** The 3000 sf piazza is the heart of the building. Two interior courtyards let light into the interior of the building. Stratton Treadway 2009.

- Interior Courtyard
- Piazza/Gathering
- Classrooms



**Figure 59** Classrooms at the corners of the building. The classroom entrances are connected to the piazza but acoustically and visually buffered by the cloakrooms. Stratton Treadway 2009.

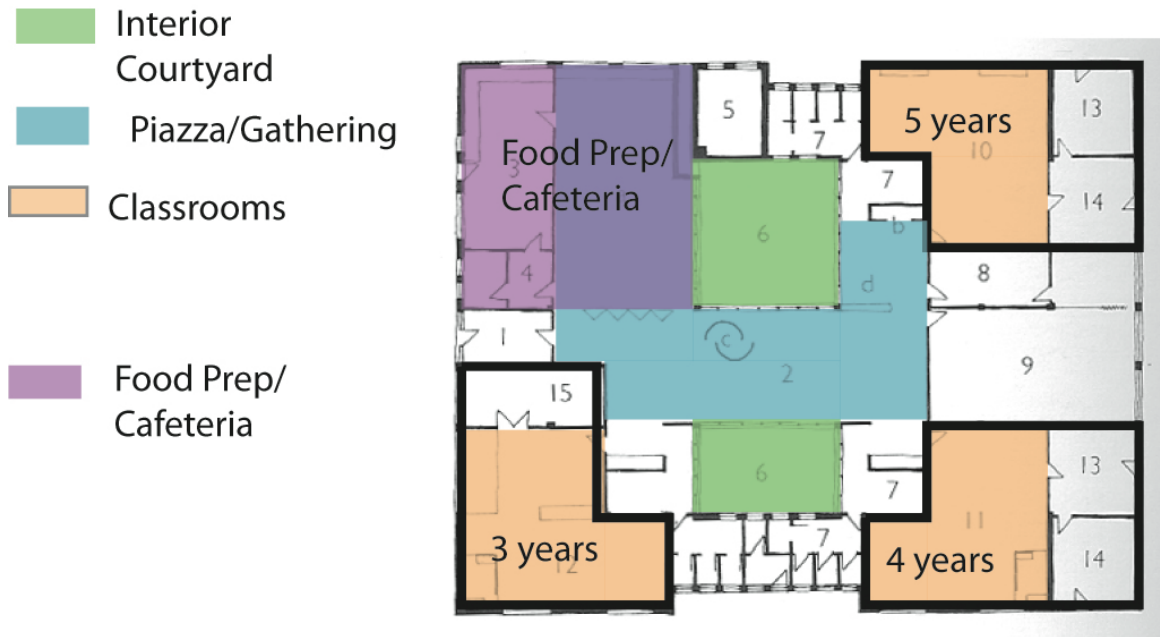


Figure 60 Food preparation (900sf) and eating together takes place in the piazza. Stratton Treadway 2009.

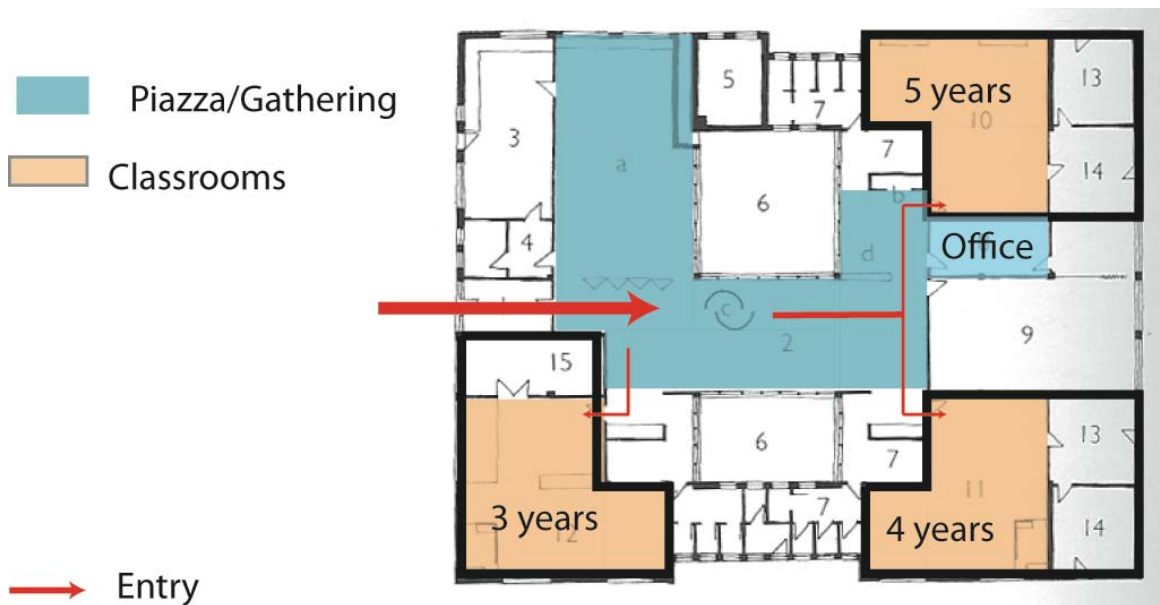
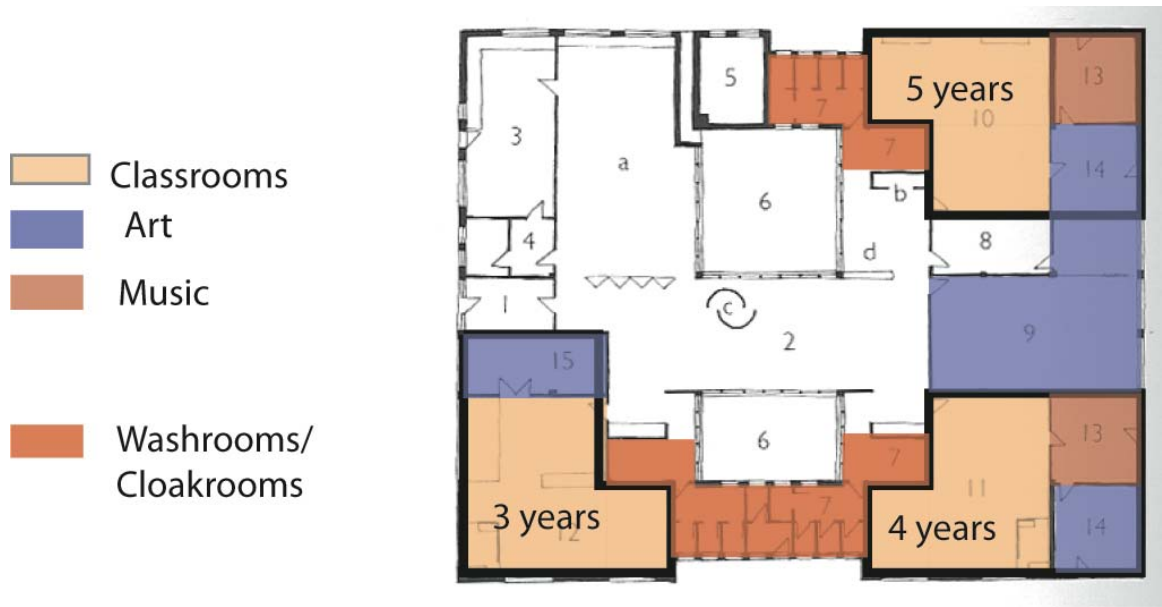


Figure 61 Children enter the piazza space and then filter to their classrooms. Stratton Treadway 2009.



**Figure 62** The classrooms are actually larger spaces with the addition of dedicated music and art rooms. A larger art workshop serves the entire school with its entry off the piazza. (A translucent wall visually connects that workshop to the piazza space.) Stratton Treadway 2009.



**Figure 63** Children access the outdoors from their classrooms. Or they can go from the piazza into the interior courtyards. Stratton Treadway 2009.

## **Chapter 5: City as Site**

American urban centers have experienced a renaissance in the past decade or so. Many people who have choices about where they live are choosing to live in city centers. But parts of the city are physically scarred and abandoned. In many American cities, one can still point to physical scars in the urban fabric that resulted from rioting that followed Dr. Martin Luther King, Jr's assassination in April 1968. Washington DC has these scars of the past and current growing pains. Corridors of poverty and faded storefronts – pawnshops, payday cashing, liquor stores – line many boulevards into the city. But in that same Washington DC -- outside the federal core of monumental limestone -- lies a city with a wealth of stable, thriving neighborhoods, Brookland and Edgewood to its west, is one of those neighborhoods.

### **Early Site Considerations**

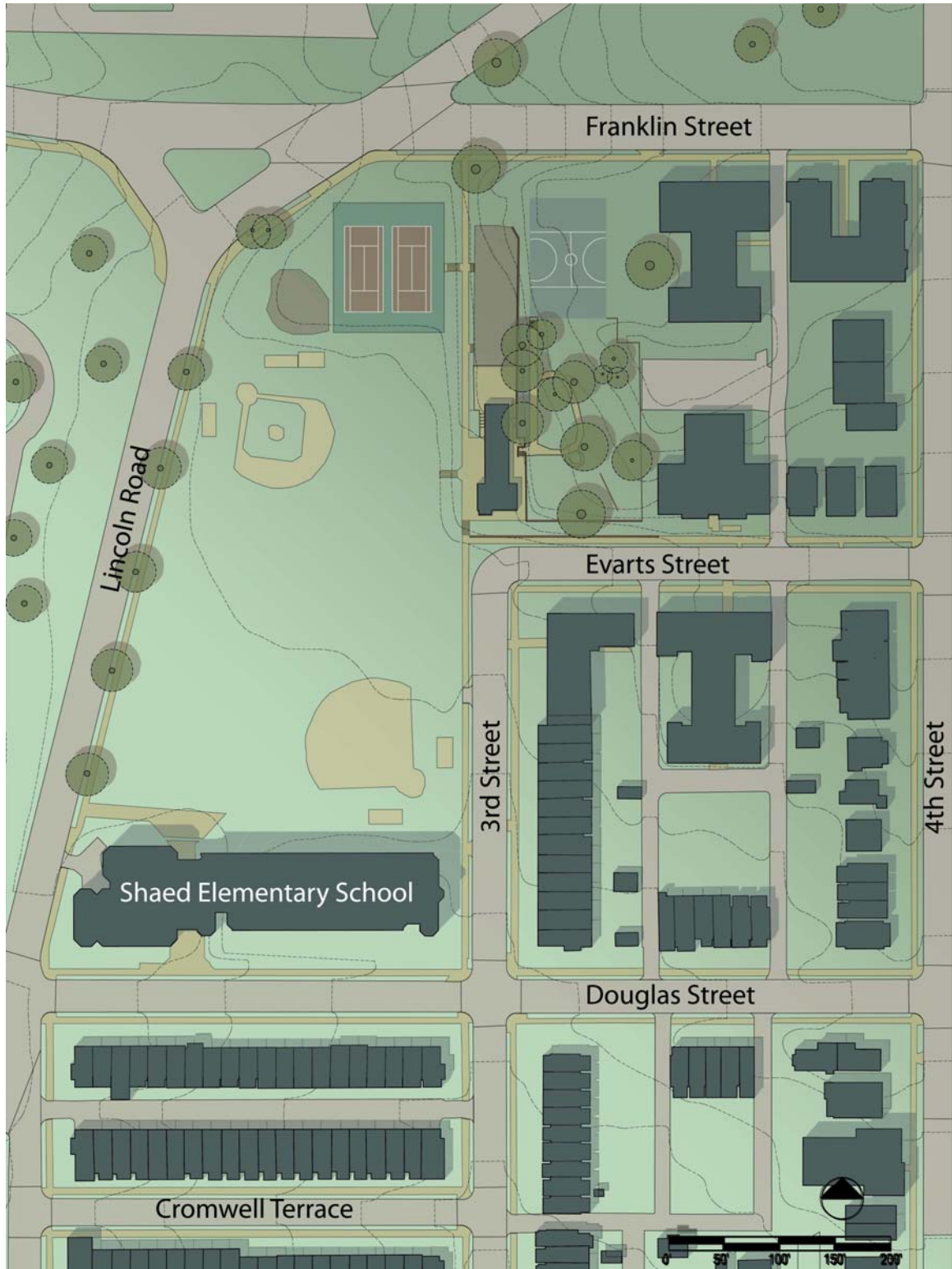
Candidate sites were selected next to or in neighborhoods that seemed to offer:

- an appropriate density of residents to make a neighborhood, (evaluated subjectively.)
- residents in relatively stable, long-term living situations.
- A site large enough to offer possibilities for a community play space
- A site on bus lines or metrorail

As sites were evaluated for their appropriateness for a preschool, it became clear that a site near an elementary school might offer the possibility of collocating resources and uniting families where one child might go to the elementary school and another to the center.



**Proposed Site: Edgewood Recreation Center**



**Figure 64 The Edgewood Recreation Center site. Stratton Treadway 2009**

East West Section at Everts Street facing North

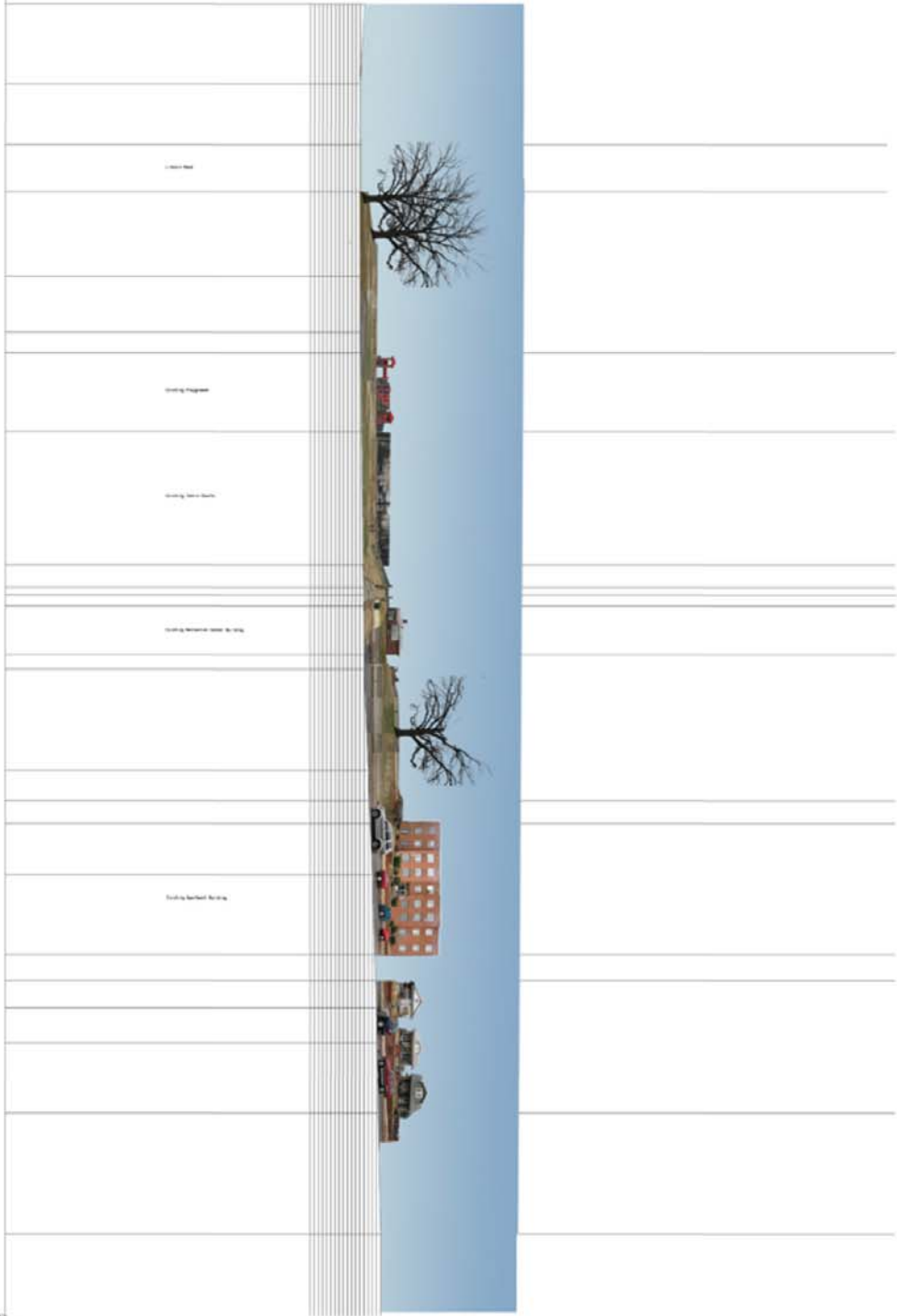


Figure 65 East West section. Stratton Treadway 2009.

# North South Section at 3rd Street facing East

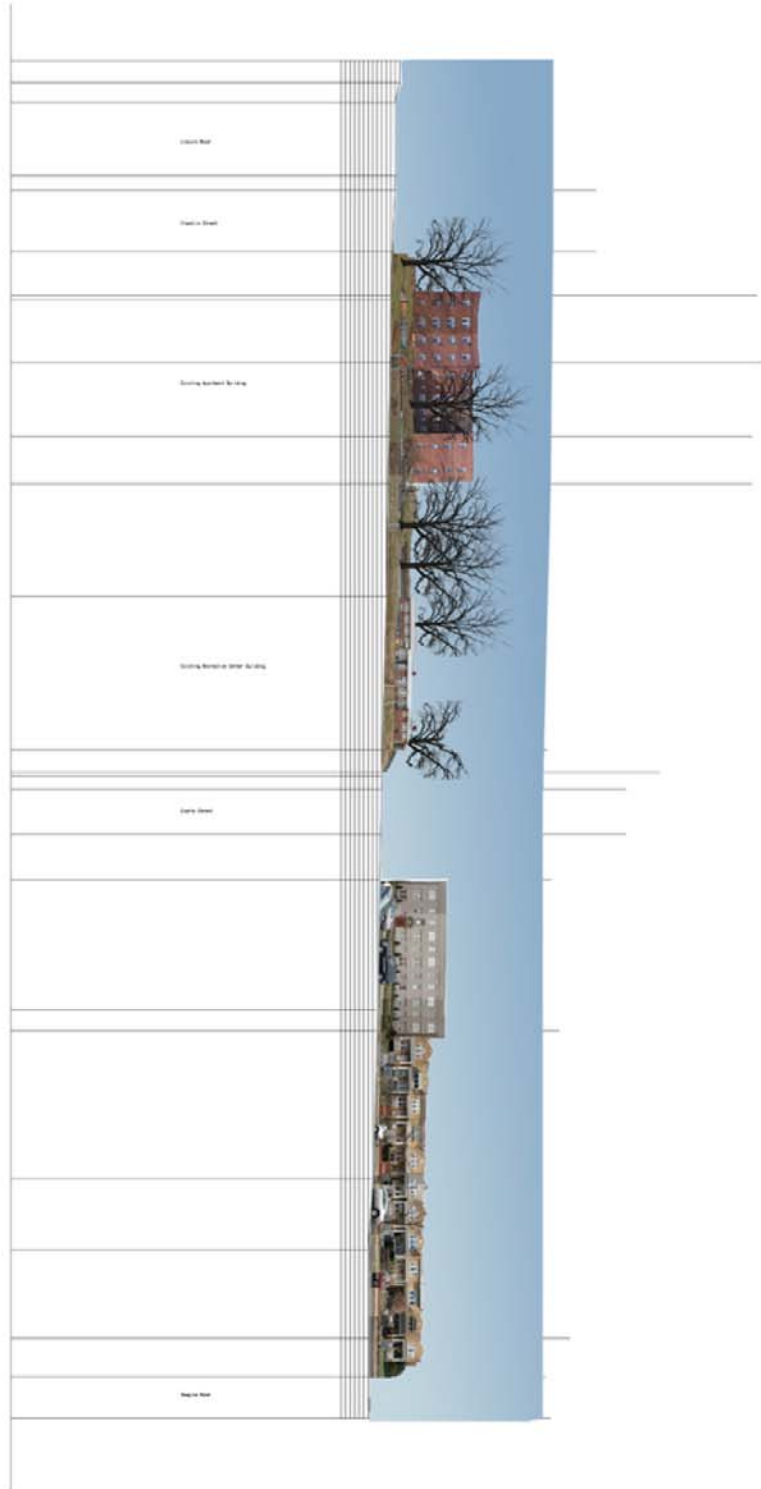


Figure 66 North South section. Stratton Treadway 2009.



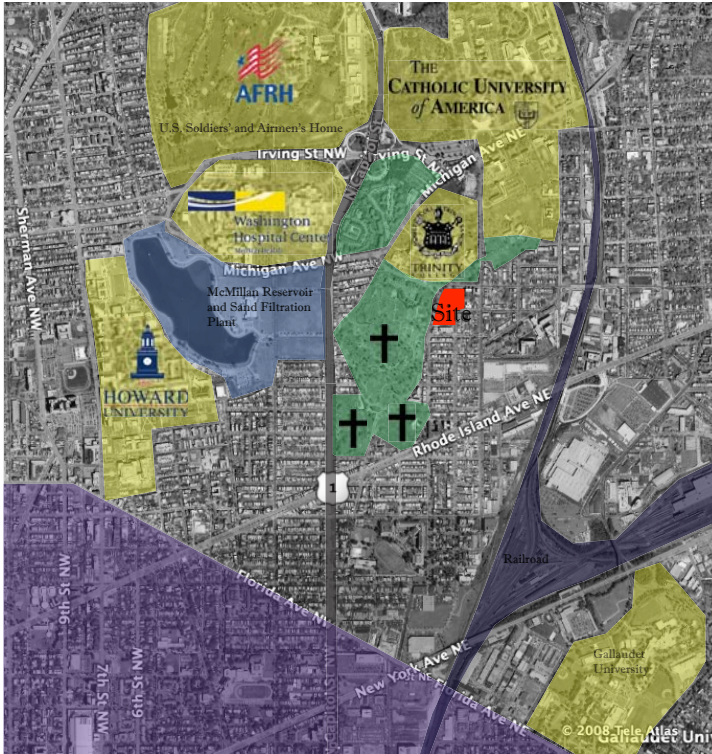
**Figure 67 A 1928 Sanborn map shows the overall relationship between the proposed site, Florida Avenue and the large land-grant institutions in the center of the city. Stratton Treadway 2008.**

At its founding, the street grid of Washington DC extended as far north as Boundary Avenue, currently Florida Avenue. North of Boundary Avenue were the suburbs of the time. Large tracts of available land were divided and granted over the years to various large institutions (Figure 67). The Old Soldiers' Home housed President Abraham Lincoln's weekend retreat from wartime Washington DC. Glenwood Cemetery, once the site of a farm, was chartered by Congress in 1854. The Institute for the Deaf and Dumb, now Gallaudet University, was chartered by Congress in 1864. Trinity College, the northern border of the site was founded in 1897. The main buildings of Catholic University of America, home of the Basilica of the Immaculate Conception

(visible from the site), is a bit further north and Howard University (founded 1867), one of the nation's first historically black colleges, is just south of the McMillan Reservoir. McMillan Reservoir was built in 1902 and the Sand Filtration Plant added in 1906 to meet the clean water needs of the growing city. Now abandoned and slated for redevelopment, the two rows of cylindrical forms are a monument to a Washington of another time (Figure 68).



**Figure 68 McMillan Sand Filtration Plant visible from North Capitol Street.**  
[http://upload.wikimedia.org/wikipedia/commons/e/e9/McMillan\\_Sand\\_Filtration.JPG](http://upload.wikimedia.org/wikipedia/commons/e/e9/McMillan_Sand_Filtration.JPG)



**Figure 69** The current configuration of large institutions north of Florida Avenue and their relationship to the proposed site. Google Maps. Stratton Treadway 2008.

In addition to federal, institutional and municipal Washington, there exists also a vibrant middle-class community with many children of school age. The Edgewood Recreation Center site (Figure 64) lies at the joining seam of landscape between the large tracts of institutionally-owned land and the fine-grain of Washington DC's enduring domestic fabric of row houses and small apartment buildings. Indeed the name of Edgewood may well be a name related to the siting of houses on the edge of the more rural landscape. (Figures 73, 74, 75)



**Figure 70 Buildings in the landscape on the Trinity College campus. Google Maps. Stratton Treadway 2009.**



**Figure 71 Buildings in the urban grid. Google Maps. Stratton Treadway 2009.**



Figure 72 The Edgewood site lies at the junction between landscape and urban grid, opening up design opportunities. Google Maps. Stratton Treadway 2009.



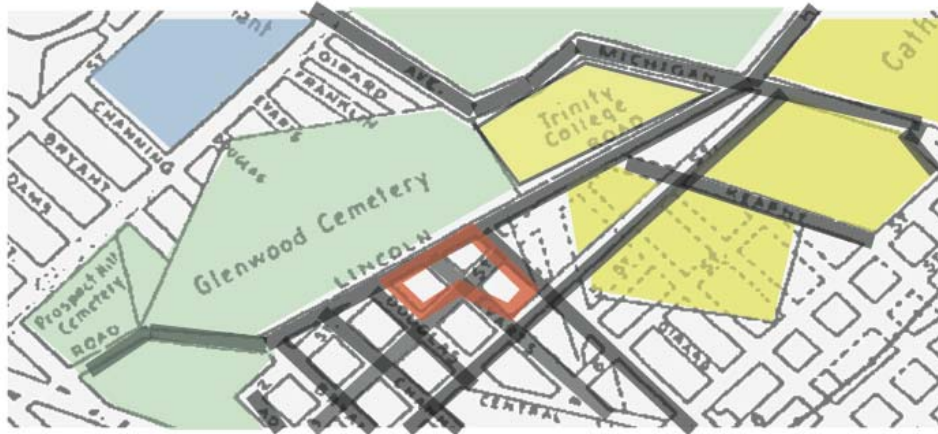
Figure 73 The site is bordered mostly by single family homes and small apartment buildings. Google Maps. Stratton Treadway 2009.





**Figure 74** The site has urban edges and landscape edges. Google Maps. Stratton Treadway 2009.

The solid urban edges are located to the south and east of the site, with landscape edges to the west and east. (Figure 74) At the eastern-most edge of the site above Evarts Street, the high point makes a landscape edge to the site until one reaches the top of the hill and can see into the parking lot of the adjacent apartments. (Figure 78) There is an opportunity for this thesis project to create a street edge for the site reconnecting it again to the historic urban residential fabric (Figure 75).



**Figure 75 A 1928 Sanborn map shows that Evarts and 3rd Streets used to continue on through the site. Stratton Treadway 2009.**

In addition to the opportunity to make an urban edge to the south and east, other factors also make an orientation to the west or north less appealing. For one thing, Lincoln Road and Franklin Street are major thoroughfares at this point. Despite having parking lanes adjacent to the site, their sidewalks seem dangerous for pre-school children and a drop-off lane would be impossible (Figure 76). In addition, the afternoon sun makes glare and solar gain from the west uncomfortable. (Figure 77)

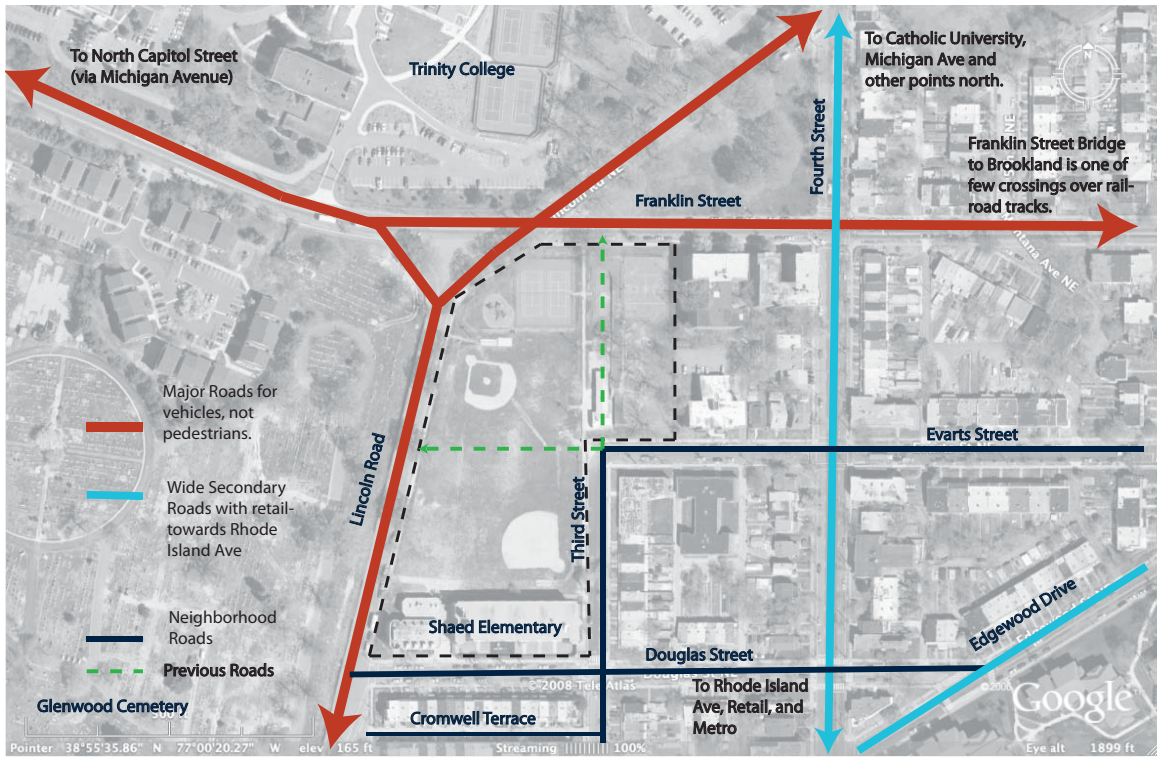


Figure 76 Hierarchy of roads around the site. Google Maps. Stratton Treadway 2009.

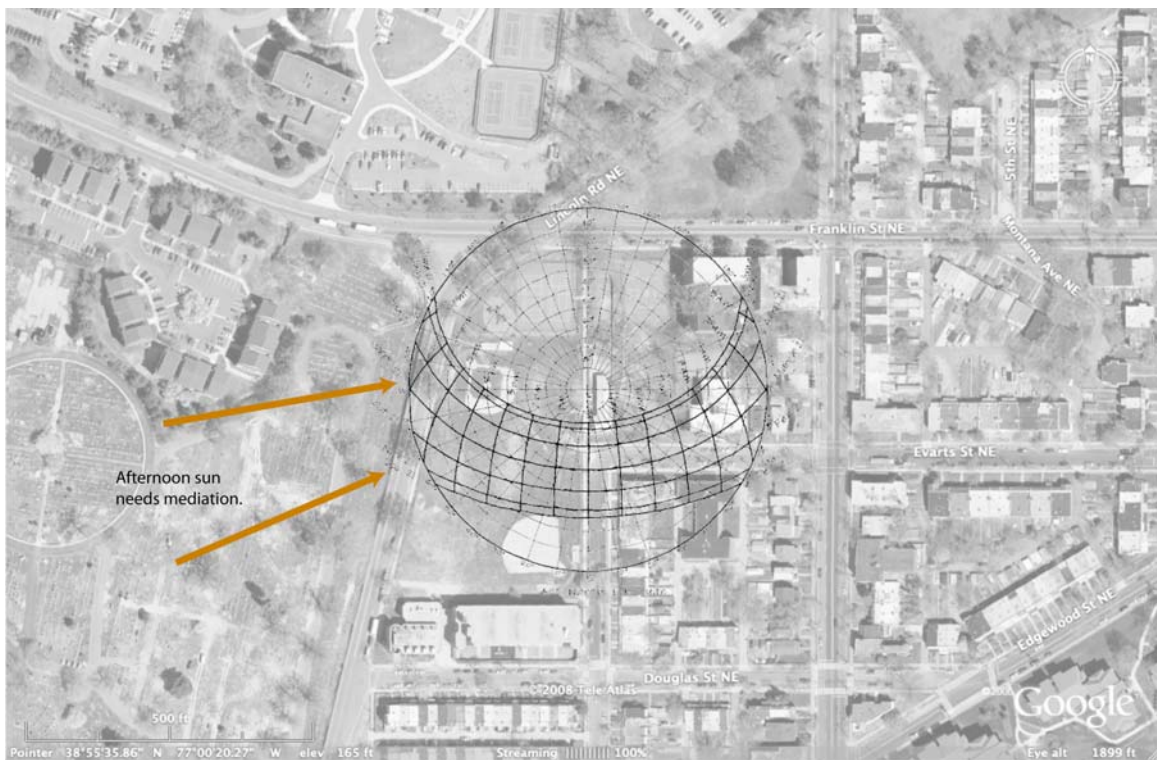


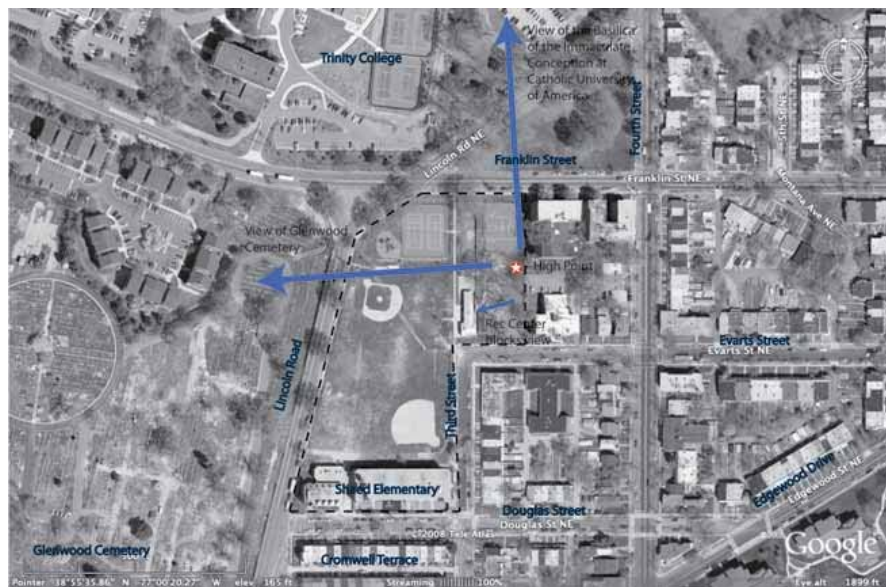
Figure 77 The afternoon sun is a problem for western facing activities. Google Maps. Stratton Treadway 2009



View across to Glenwood Cemetery from high point. Stratton Treadway 2008.



View to Basilica of the Immaculate Conception. Stratton Treadway 2008.

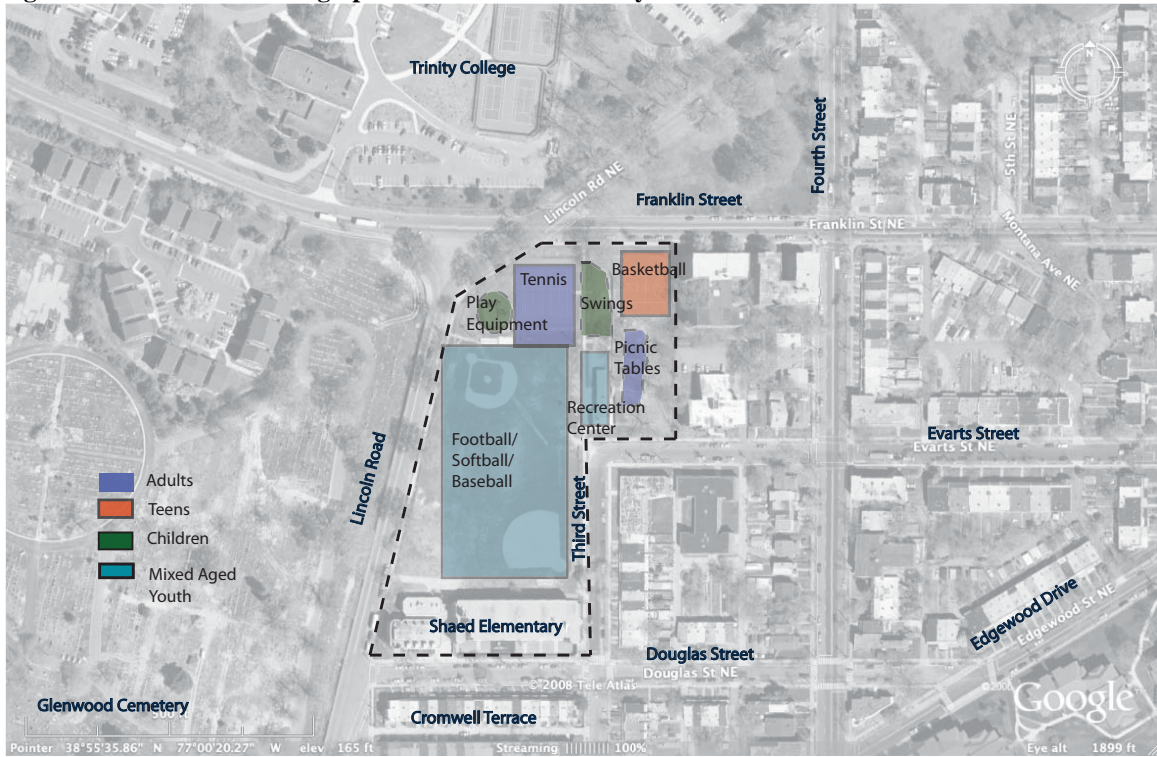


View back towards Evarts Street from high point. Stratton Treadway 2008.



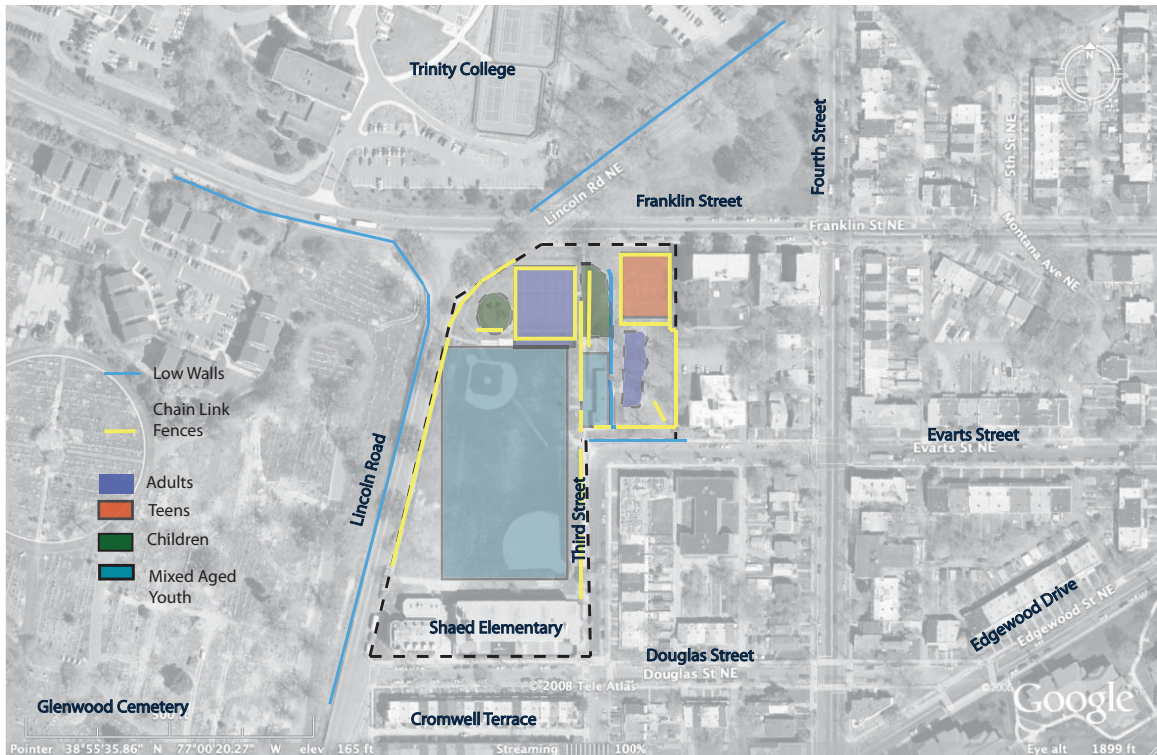
The Recreation Center Building blocks the view. Stratton Treadway 2008.

**Figure 78 Views from the high point. Stratton Treadway 2009**



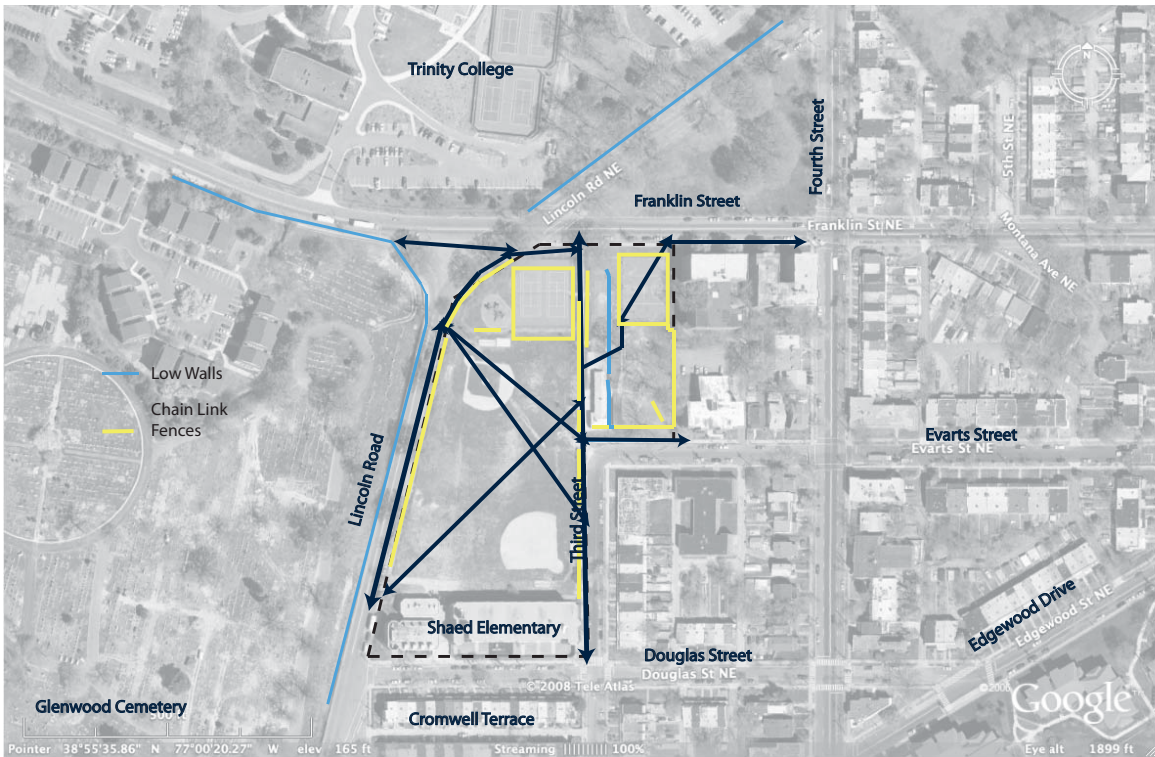
**Figure 79 Current configuration of the site as a recreation center. Colors indicate the venues intended for use by various age groups. Stratton Treadway 2009.**

The site is currently used for a Recreation Center and Community Playground. However, the recreation venues have been deposited on the site seemingly without regard for the users. (Figure 82) For example, the swings and the playground equipment, the places most likely to be used by young children, are separated by a fenced-in tennis court. The picnic area, the only venue with seating, has its view of most activity on the site blocked by the Recreation Center building (Figure 79). That building is locked on the weekends, denying users of the space a working bathroom.

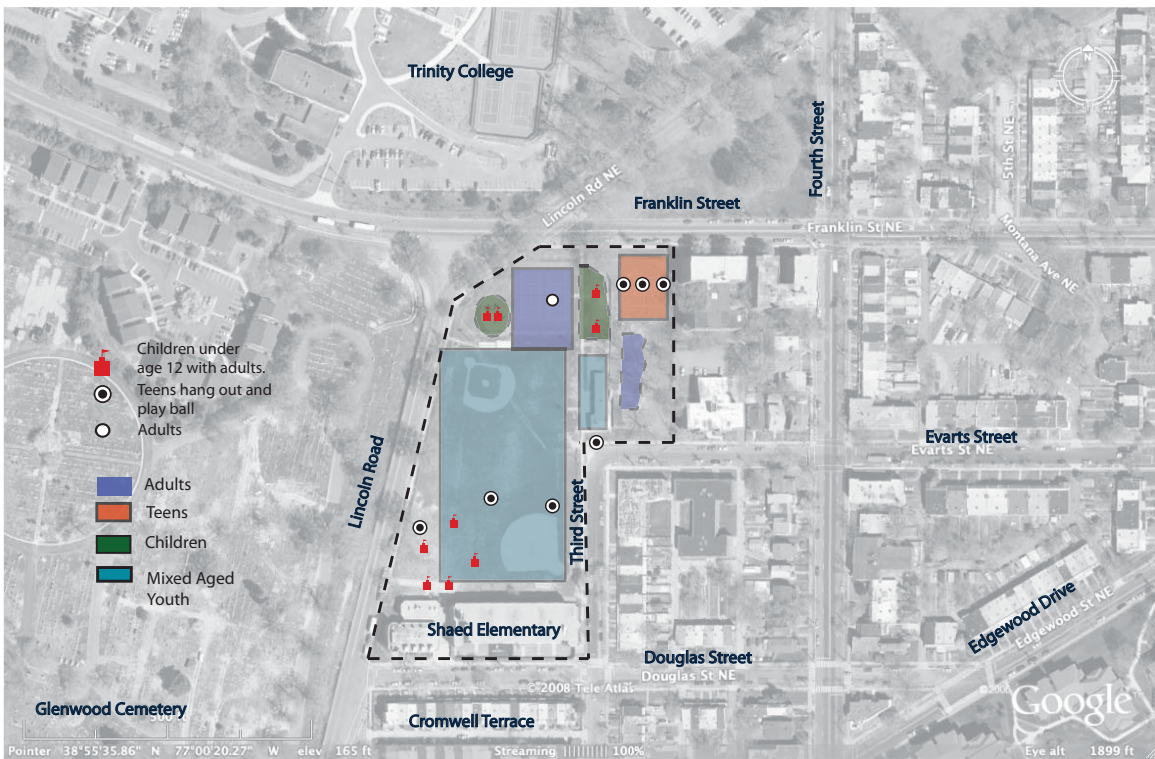


**Figure 80 Fences, walls and recreation venues. Stratton Treadway 2009.**

The placement of chain link fences around the recreation venues further chops up the site (Figure 80). Access to venues, especially the isolated playground, is very limited from the main north-south through the site. Clearly movement on the site is biased in the North-South direction by the placement of the fences and venues. Indeed that is primarily what was observed on several occasions, although people do regularly cut through the site diagonally (Figure 81). Indeed, with fences on both sides, the walk along the Third St sidewalk through the site is more of an axial path than anything like a meander that would invite people to stay a while. There are reasons for such efficiency, but it also a missed opportunity to engage pedestrians in the “work” of playfulness.



**Figure 81** Circulation paths which do not always follow sidewalks and paths. Stratton Treadway 2009



**Figure 82** Ways in which the author observed the site being used. Stratton Treadway 2009.

Young men and women hang out together on the low wall to the south of Recreation Center Building where Third and Evarts Sts. currently end. They also hang out on the bleachers on the side of the ball field. Young men play basketball on the courts and sometimes football on the field. Children under 12 rarely play here without adult supervision. The portion of the field closest to the school is used during school hours for recess and/or physical education classes. Again, this diagram (Figure 82) shows how spaces used by various age groups of people are located at a distance from each other. A good design of the site would remedy this disconnect and include places for people of all ages to feel as if they belong there.



**Figure 83 To the east of the Recreation Center is a narrow and hidden passage which invites antisocial behavior. Stratton Treadway 2008.**





Figure 84 Most large trees are located near the high point of the site. Stratton Treadway 2009.



Figure 85 Water pools on the playing field after it rains and has no place to go. Stratton Treadway 2009.

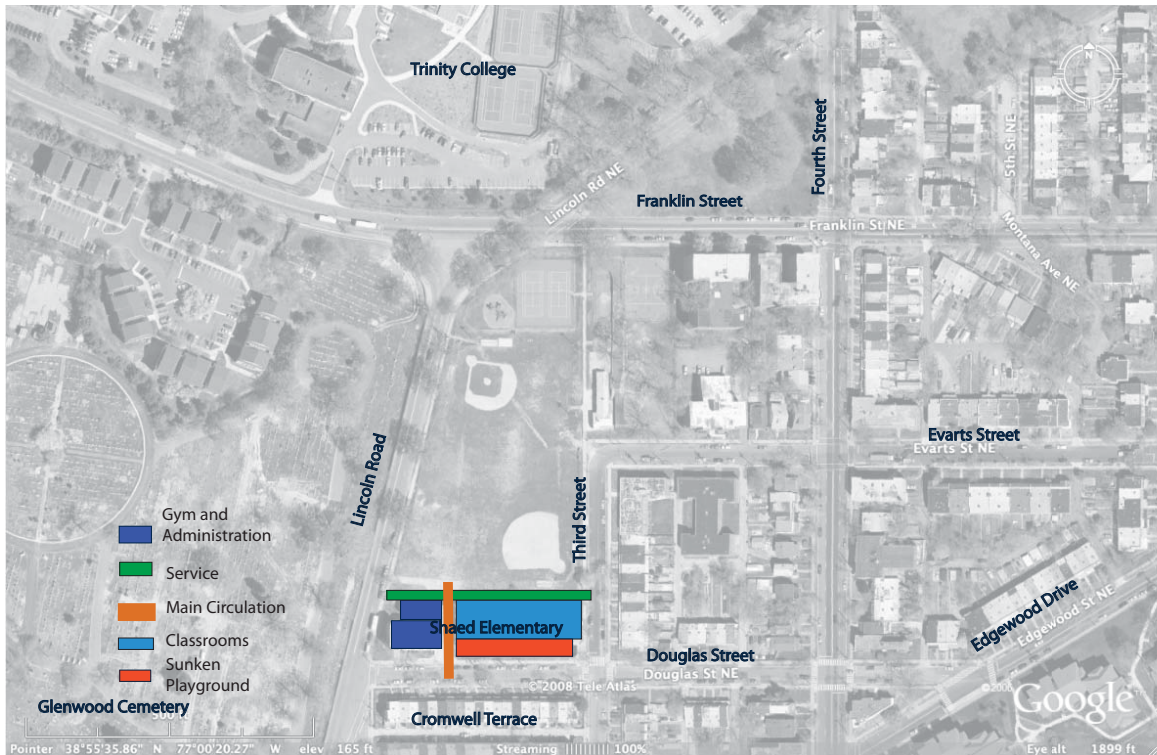
Most of the landscaping is turf. Tall trees edge the site outside the chain link fence along the road (Figure 84). The eastern most edge of the site, the picnic area, is the

most natural, with large picturesque trees. But it is also the most remote from other activities on the site. The large tree closest to Evarts Street is missing its entire top, so it is likely not worth saving.



Figure 86 Diagram comparing the large area of low fields to the high plateau. Stratton Treadway 2009.

Shaed Elementary School (Figure 87), which currently enrolls fewer than 250 children in grades pre-K through sixth, is on the southern edge of the site. Most of its students perform at basic or below basic levels on standardized tests and more than 80% are eligible to receive free and reduced price lunches – an accepted measure of the poverty level of the student body. The school population is made up of children of African American (92%) and Hispanic (8%) descent who primarily reside in the surrounding neighborhood to the east and south of the site.



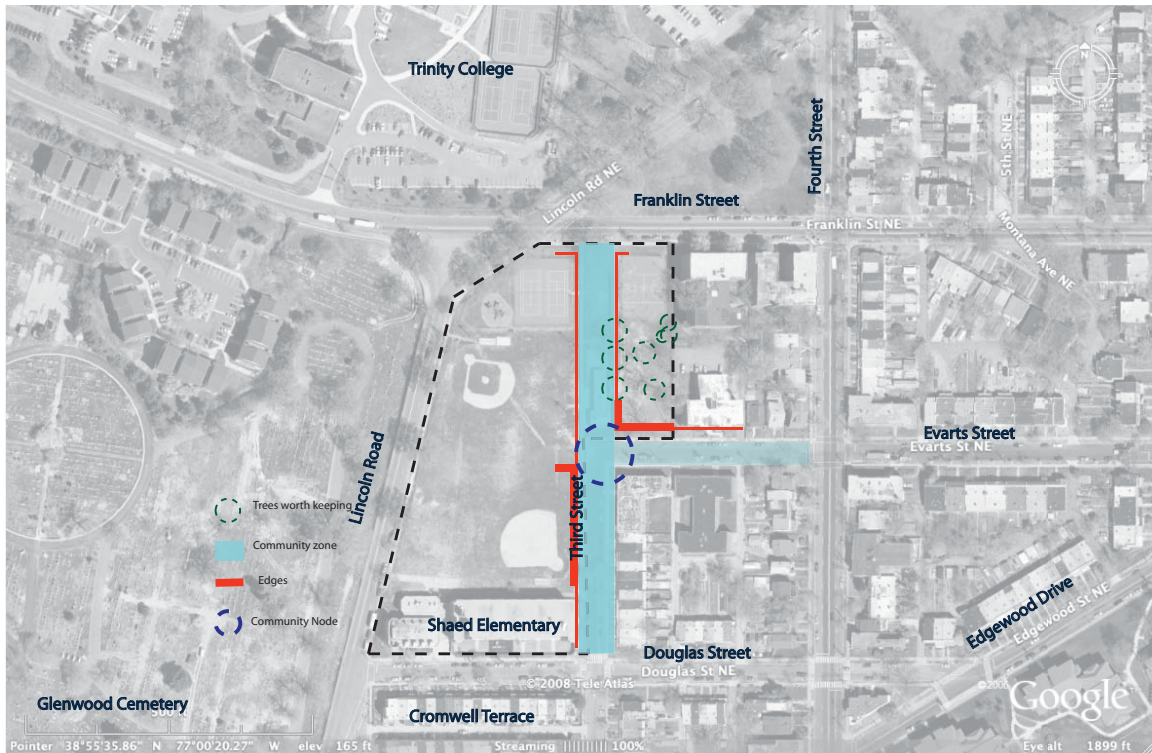
**Figure 87 The disposition of functions within Shaed Elementary School. Stratton Treadway 2009.**

Locating a Child Development Center near the elementary school will provide one easy drop-off for parents in the morning and allow for resources to be shared between the two institutions. The site already contains play and learning of a certain traditional sort; this thesis will examine the qualities of place that combine play and learning into something richer.

## **Chapter 6: Design Opportunities and Challenges**

The site is large and the building program small. How can the building be grounded in the site in such a way that it spawns new life in the larger landscape? The varied section of the site is a challenge for visibility and an opportunity for terracing. The lack of defined edges on many sides of the site is a challenge. One challenge is to decide if the building program should participate in the orthogonal grid of the urban fabric as the historic maps indicate it once did or if it should be a pavilion in the landscape as many of the educational institutions surrounding it are. The public nature of the site and its place as a circulation spine must be maintained. This creates a siting challenge for a school which requires a certain amount of control and security for its grounds.

In *Environments for Children*, Day talks about schools as insular places where the community has its own rules and rituals – for better or for worse. As the gardens and play spaces move further away from the building, they take on a more public function. This sort of transition from urban, insular and controlled space (like a blacktop) to more public and natural space (like a playing field) is a helpful model to keep in mind as we consider the nature of the site.

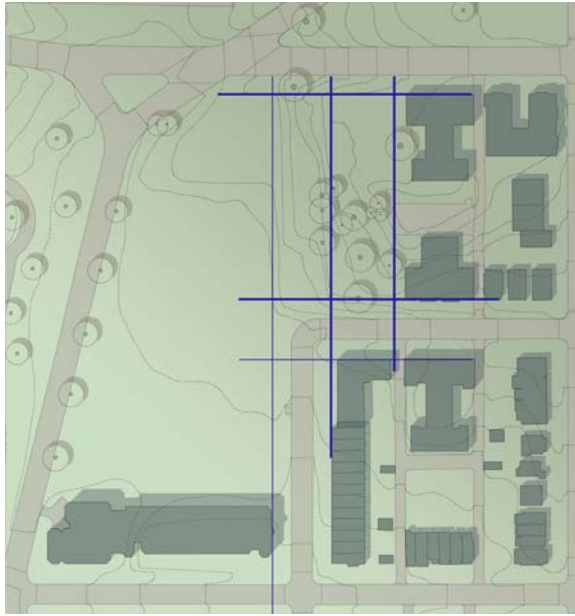


**Figure 88 Diagram showing the opportunities of the site. Stratton Treadway 2009.**

The earlier site research pointed to some real possibilities for organizing the program on this large and open site (Figure 88) First of all, the urban grid provides some edges which should be considered when placing a building within the community. Secondly, there exists a zone of opportunity for engaging the community along the main north-south circulation spine. Thirdly, the trees on the site provide an opportunity to site a facility for children in a wooded, naturalistic setting.

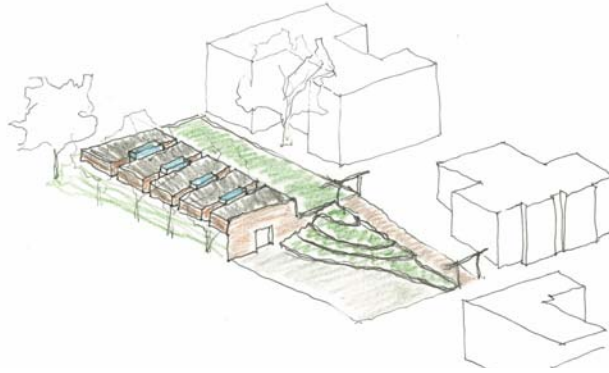
As discussed earlier, factors such as the proximity of major roads, the service side of the elementary school as well as its circulation zone, the drainage issues of the main field and the use of the field for athletic events all serve to make the portion of the site to the west of Third Street less desirable for a facility for young children.

Early on, schemes focused on the portion of the site bounded by the urban grid, noted by the regulating lines on the figure below. (Figure 89)

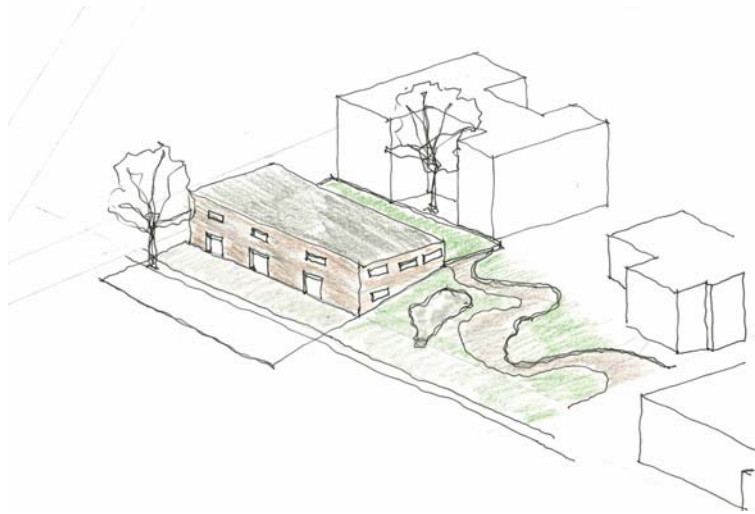


**Figure 89** Regulating lines on site. Stratton Treadway 2009.

Several parties situating the building in this region of the site were explored. All of these schemes propose placing the community functions (senior center, etc.) on the ground floor of the building and putting the program for young children on a second story. Each scheme makes a garden for the young children on the top of the hill and a community space below. Each scheme maintains a zone of community circulation through the site from north to south. These early elements of the design process were retained in the final proposal.



**Figure 90 Building as retaining wall with community space at south end of site. Entrance to school is from upper level. Stratton Treadway 2009.**



**Figure 91 Building as retaining wall with community space to west. Entrance for children on top and entrance for the community to the west. Stratton Treadway 2009.**



**Figure 92 L-shaped configuration makes community courtyard on Evarts Street. There is one entrance to the building with the Stratton Treadway 2009.**

In the end, it seemed most appropriate to have the front door of the building directly on Evarts Street (as evident in the “site possibilities” diagram (Figure 88) to facilitate community engagement with the program.



**Figure 93 Early scheme showing front door on Evarts Street with children’s garden in back of site. Stratton Treadway 2009.**

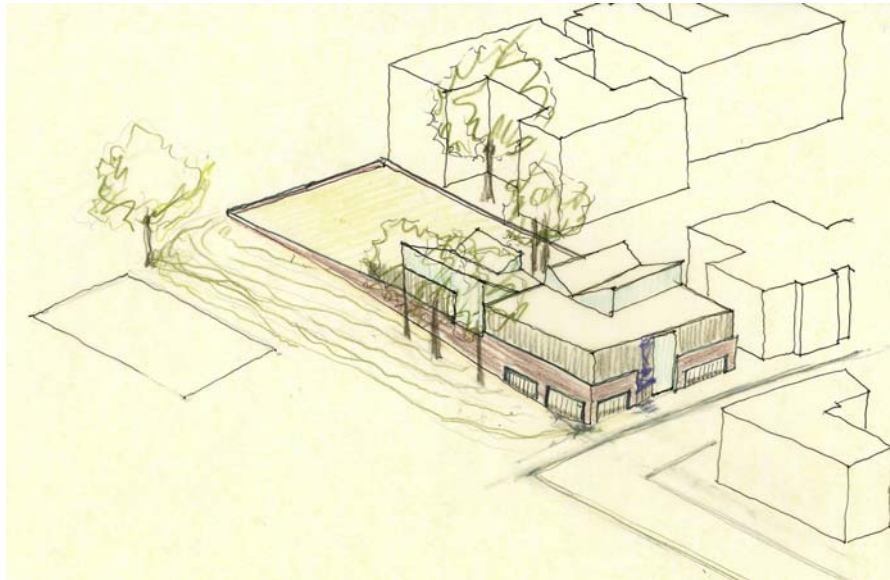


## Chapter 7: Design Proposal

### Section 1: The site and building overall

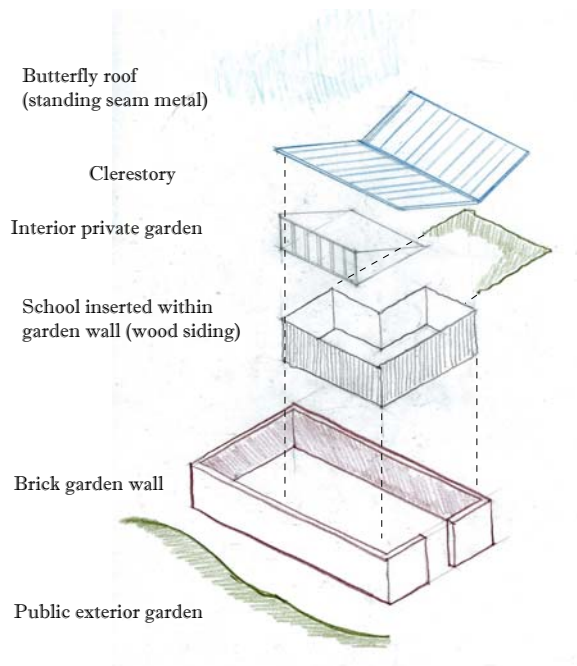
Several assumptions drove decisions about the design:

- The building should not block use of the sports fields used by the elementary school and the wider community or the main north-south circulation route.
- The building should be welcoming to the wider community – best done by situating the front door on Evarts Street and placing community program on the ground floor.
- The children need their own secure facility – best done on this site by putting the program for children on an upper floor.
- The children needed access to their own outdoor play and learning environment.



**Figure 94** Scheme at A6 showing the interior children's garden on the hill and the entire precinct surrounded by the garden wall. The front door is on Evarts Street. Stratton Treadway 2009.

## Building Layers Diagram



**Figure 95 Building Layers Diagram. Stratton Treadway 2009.**



The building is made up of several material layers. The brick garden wall wraps the entire project, containing a full story of the building on the south side and the community gardens on the north. The brick language is drawn from the surrounding neighborhood. Within that wall and on the upper level sits the school with its walls of wood siding – a material language also drawn from the surrounding houses. Butterfly

roofs allow light into the classrooms and mark the classrooms with a distinct image separate from the flat roof of the rest of the building.

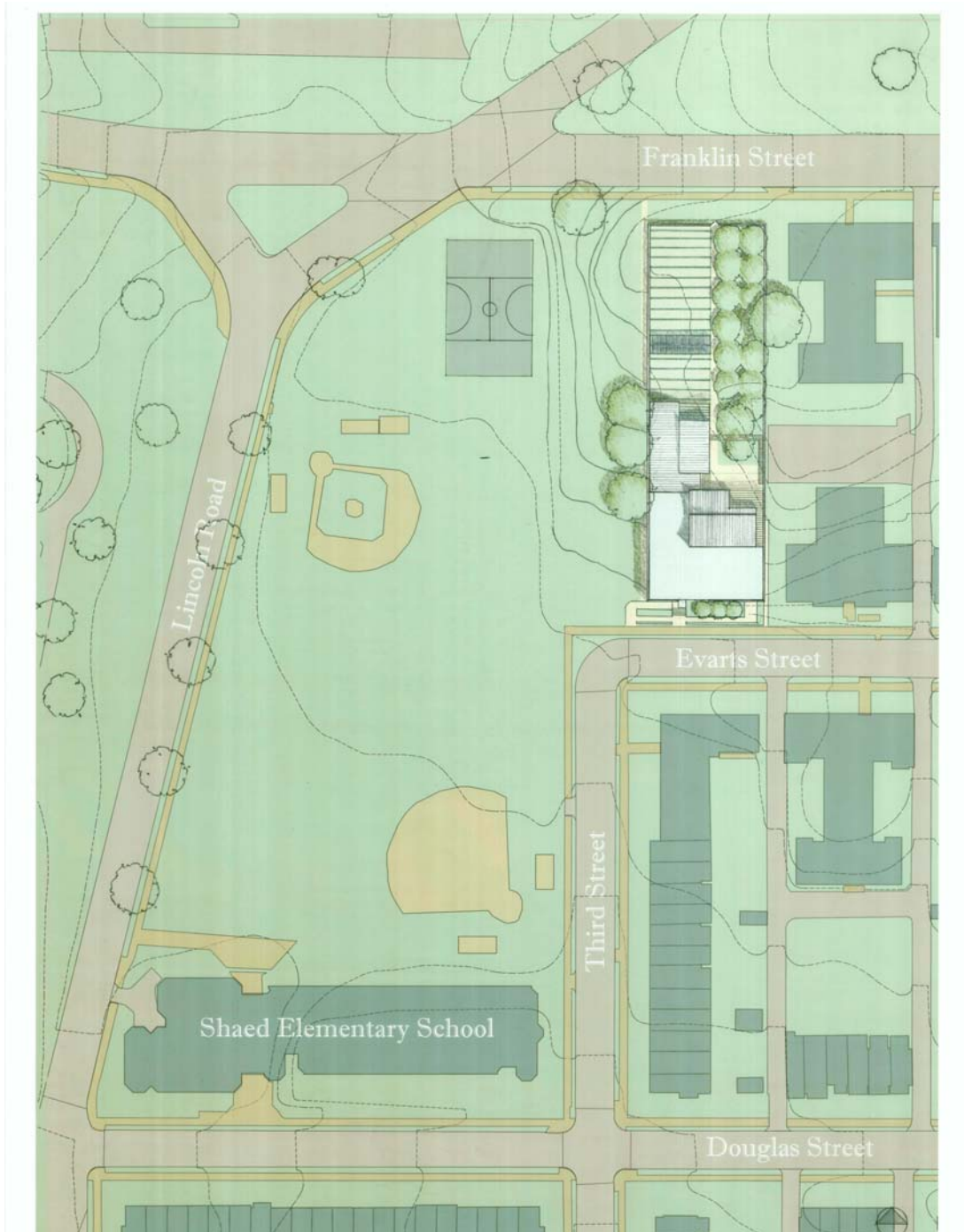


Figure 96 Site plan (A6) showing garden wall, interior garden and orchard and relationship of building to community. Stratton Treadway 2009.

In addition to the community garden space and circulation zone along the western edge of the building, there is a significant community garden space within the precinct wall (to the north) for community members to grow their own vegetables and harvest from the community fruit trees. The children and community together can grow and share the food that will nourish them throughout the summer months.

The topography of the site is graded to make a smooth grassy hill overlooking the basketball court and the other sports fields. This is lawn seating for viewing sports and a hill appropriate for sledding down in the winter and rolling down in the summer. The three existing mature oak trees are maintained in the western garden and two are maintained for the interior garden. These trees provide not only shade, but a sense of history of the place – they are many times older than the children who play here – and an important connection to nature not always available to children who grow up in the city.



**Figure 97 Long section through the site showing the entry on Evarts Street, up through the stair and the 2-3-year-old-classroom, the school garden and the community garden. Stratton Treadway 2009.**

## Section 2: Community Inside the Building

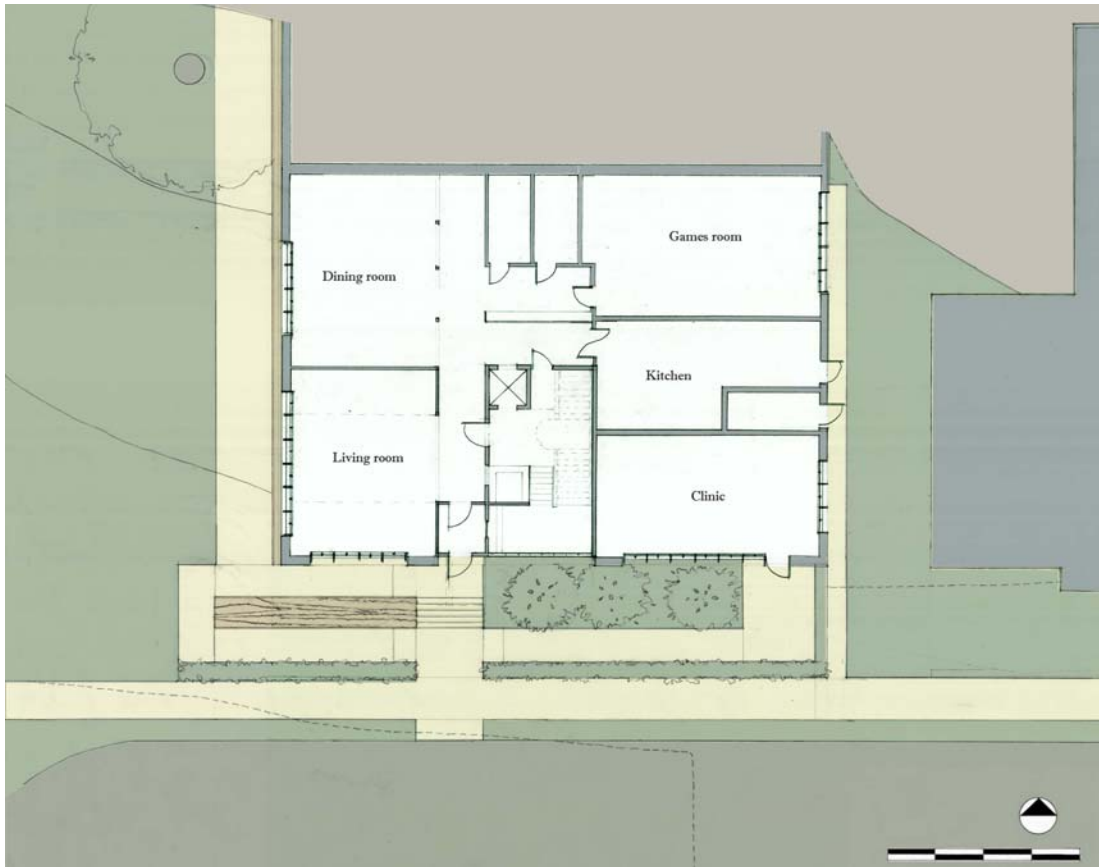


Figure 98 Ground floor plan (A6). Stratton Treadway 2009.

The ground floor of the building is devoted to program for the community – which includes children, families, and senior citizens. The clinic has a separate entrance to keep germs away from the rest of the community. The living room on the southwest corner of the ground floor provides an opportunity for the community and families to mix during the morning and evening hours. In this configuration, the school begins at the secure door in the center of the building where parents sign their children in and then proceed through the stairway – or vertical threshold – to the school level.

The scale of the building is intended to be domestic. It is an institutional building, but small. Its main function is to be a welcoming place for small children who require a nurturing and sheltered environment. The south façade facing Evarts Street shown in context (Figure 99), shows how the language of the brick wall relates to the brick of the neighboring apartment buildings and row houses and how the building is of a relatively small scale.



**Figure 99 Evarts Street facade (A6) is the face to the community. Stratton Treadway 2009.**



**Figure 100** Entry from Evarts Street. A family enters the building and a father and child play outside. Stratton Treadway 2009.

## **Section 2: Plan by Ritual**

A series of diagrams related to ritual and routine began the design of the school floor and the classrooms. The diagrams show the transition points between large group activities and class activities, free activities such as gathering in the morning and more controlled activities like group time. Of course, the space for taking off coats is at a transition point between inside and outside, between leaving the family and joining the group. The location and qualities of a naptime space are different than those spaces in which children prepare and share meals.



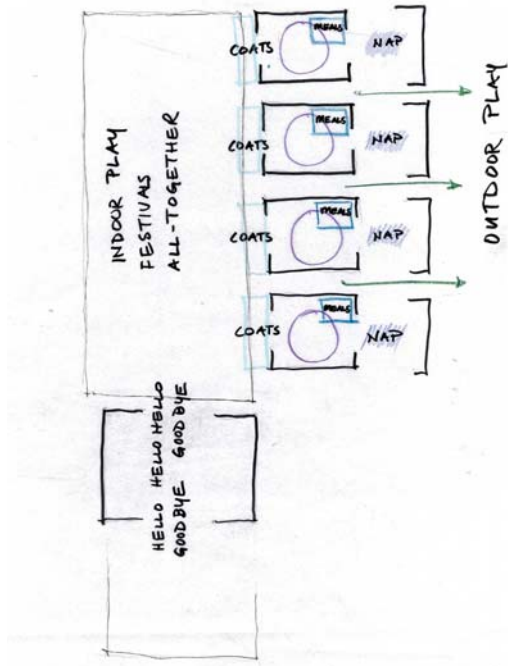


Figure 101 Plan by Ritual Diagram 1. Stratton Treadway 2009.

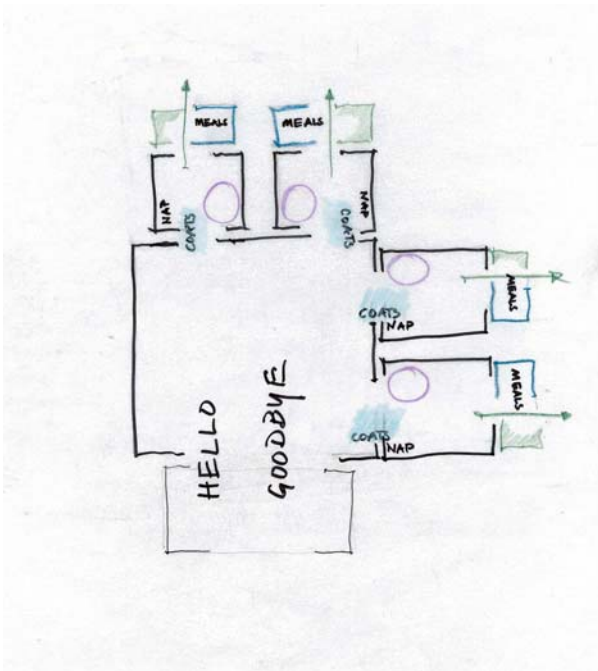
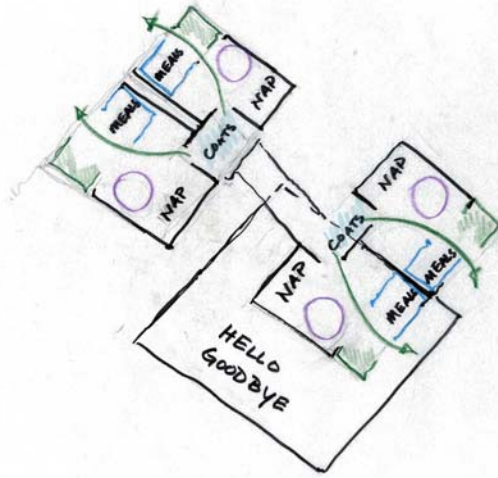


Figure 102 Plan by Ritual Diagram 2. Stratton Treadway 2009.

The diagram might be modified in this way for a two story scheme.



**Figure 103 Two-story plan by ritual. Stratton Treadway 2009.**

Ultimately the design of the school presented at the A6 public review had the classrooms grouped in two wings of the building, one for younger children closer to the entrance and one for older children at the back of the building closer to the garden – where they could be expected to share in more responsibilities for cultivating and maintaining the garden. (Figure 104) The entry porch for the older pre-school children doubles as a performance and gathering space for the entire school population at special festival times. A meal can be shared in this space at harvest time. (Figure 105)

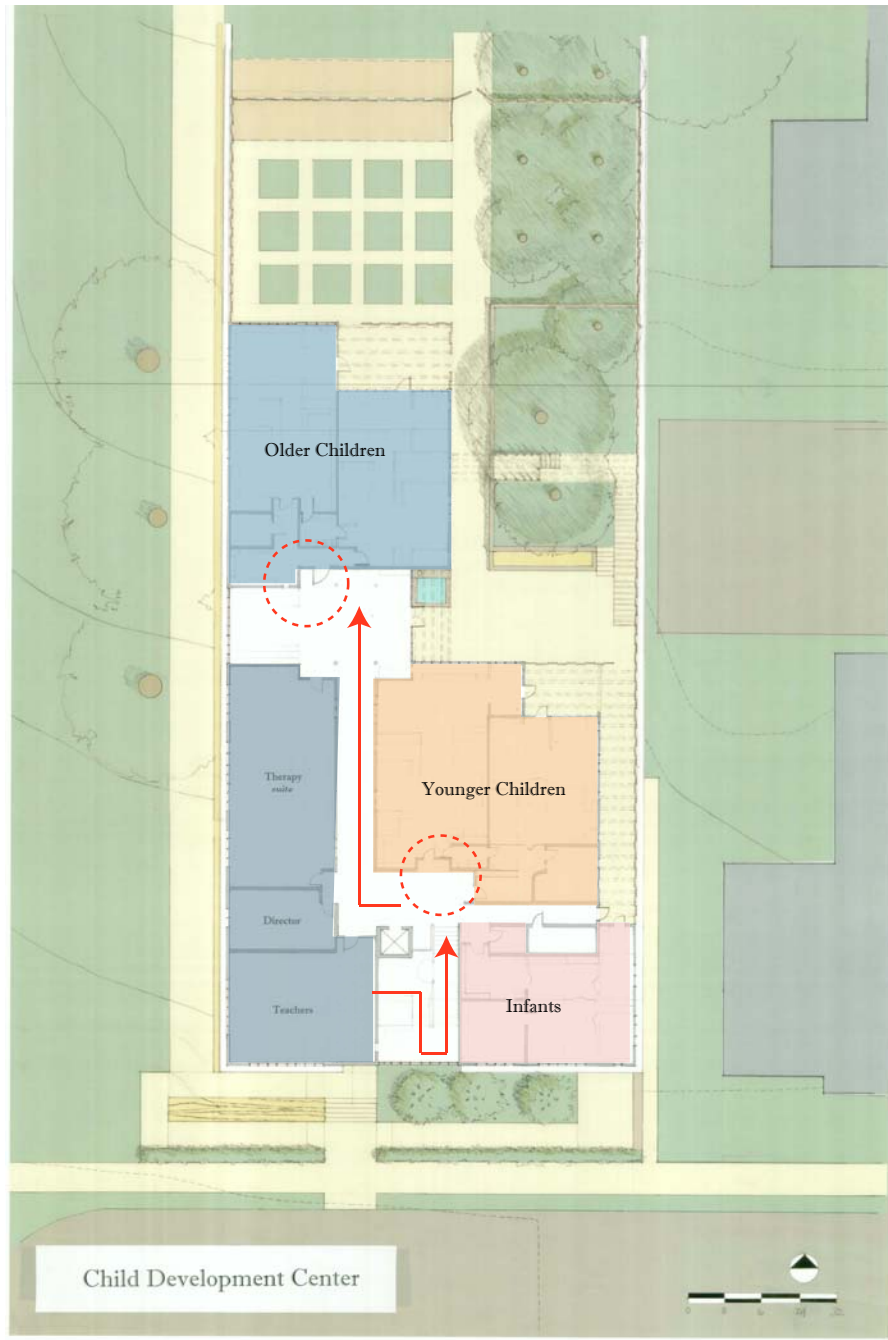


Figure 104 School-level plan showing classroom clusters, entry, and classroom porches. Stratton Treadway 2009.



**Figure 105 Section showing a performance in the gathering space and the relationship of the two gardens. Stratton Treadway 2009.**

All of the classrooms have direct access to outside work terraces and from there to the garden play space and the cultivated garden plots and fruit trees. The plan of the school garden attempts to expose the children to a variety of elemental experiences and connect them to the cycles of the earth and the changing seasons. (Figure 106)



**Figure 106** School garden is designed around an existing hill with mature oak trees. It is designed to give the children experiences with the elements of nature and the seasonal cycles. Stratton Treadway 2009.

Children can dig in the sand and earth as they tend the garden. They experience the rains as they drain off the butterfly roofs into a central cistern. That water will later be used to water the garden. A small amount of the water is allowed to fill a small pool

by the gathering space entrance so the children can experience the rain in another way. The pool is dry when it's not raining. (Figure 107)



**Figure 107** Section through the piazza space looking into the garden showing the way the butterfly roofs overlap the space and drain into the water pool and cistern. Stratton Treadway 2009.

The fruit trees provide fragrant breezes. Air as an element is also experienced in the wind in the trees. Trees represent the element of fire. So do the kiln-fired bricks of the garden wall.

### **Section 3: Classroom Organization**

The diagram of the classroom must be different for infants than for four and five-year-olds. The rituals and daily rhythms of these classrooms are necessarily different of the developmental stages of the children. Infants and toddlers require a secluded place for sleep and quiet activities such as nursing. They do not require much space at all for climbing and jumping or for reading (though they do require some). (Figure 108) Older

preschoolers need to run and jump and have a larger space devoted to reading and playing games of imagination. They can easily put out cots in the room for naptime, however. (Figure 109)

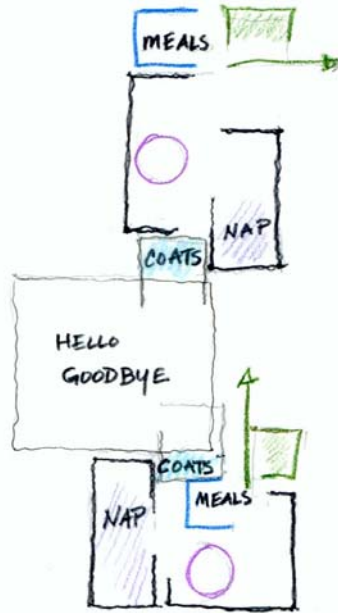


Figure 108 Plan by ritual for infants and toddlers. Stratton Treadway 2009.

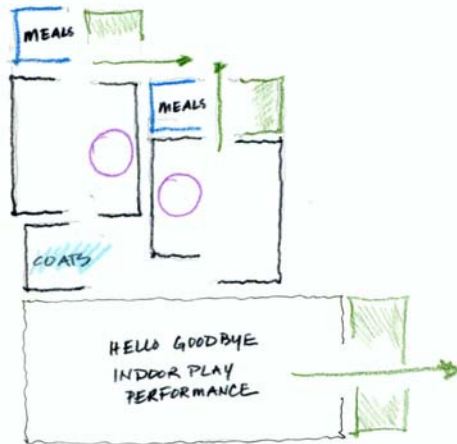


Figure 109 Plan by ritual for older preschool children. Stratton Treadway 2009.

The design of the classrooms was further influenced by the suggestions of Anita Rui Olds – creating a messy zone with impervious flooring, arranging the doors to create quiet corners and active zones, arranging the furniture along the pathway between the doors.<sup>13</sup>

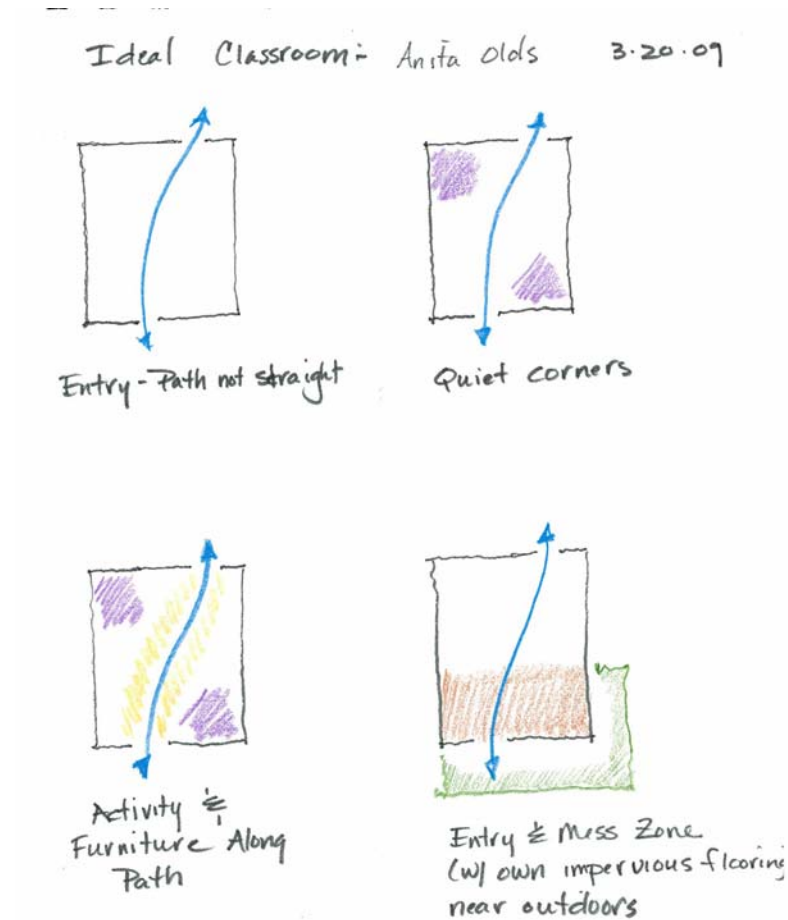


Figure 110 Diagrams of classroom based on Olds' ideas. Stratton Treadway 2009.

In the scheme developed for this project, each classroom has an interior wall and a wall against the garden. The active zone of the classroom is placed against the garden and the quiet zone against the interior wall. The messy zone and a wet zone for play with sand

<sup>13</sup> Olds, Chapter 7, "Zoning a Group Room," pp. 137-165.



and water are closest to the door leading to the outdoor project terrace and the garden.

(Figure 111)

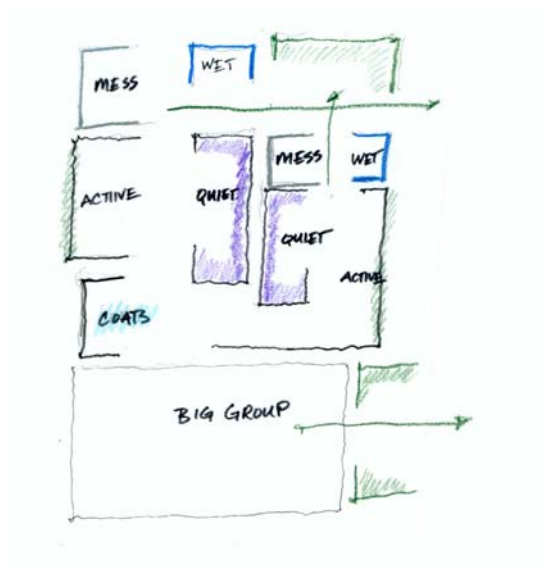
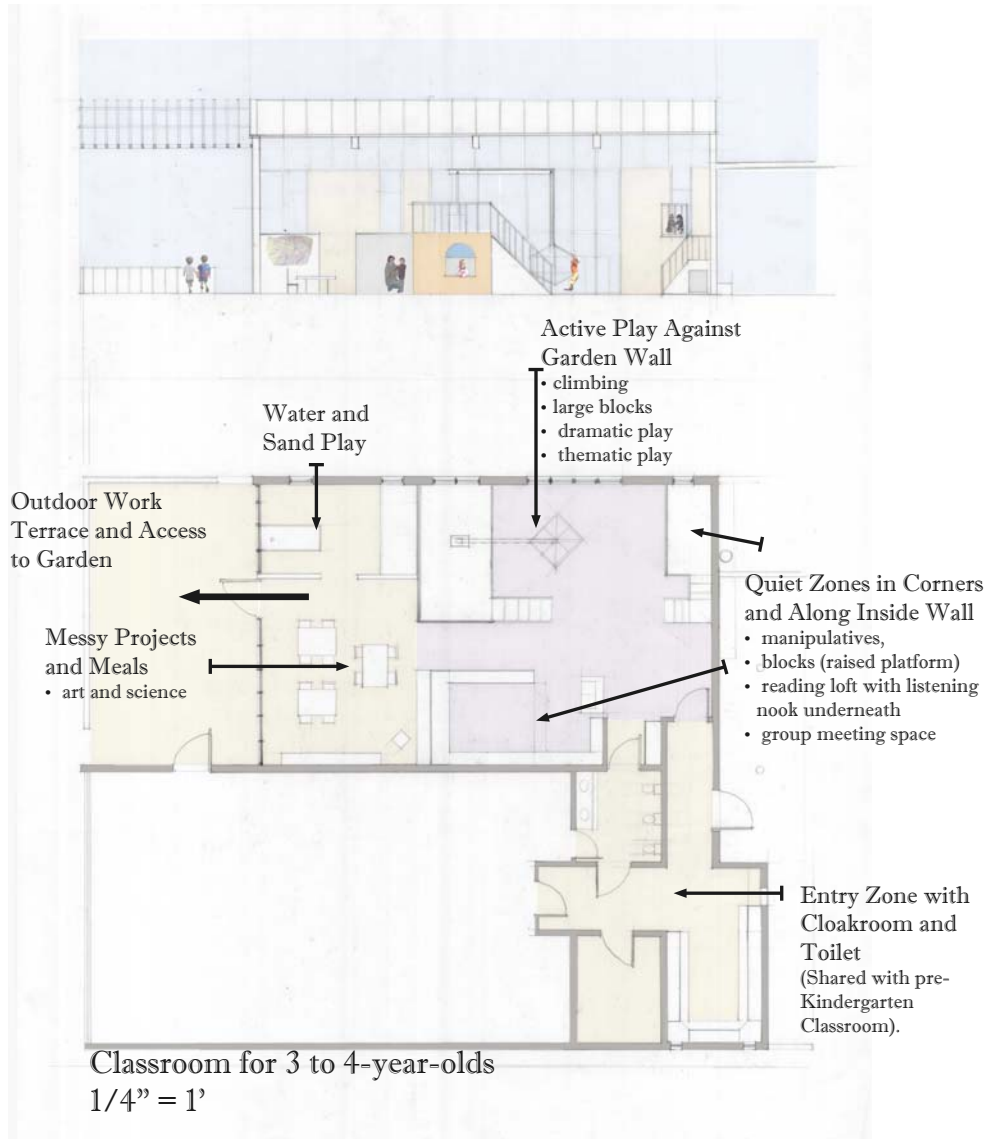


Figure 111 Diagram of older child classrooms in the language of Old's diagrams. Stratton Treadway 2009.

The classrooms for the older children contain larger platforms and climbing equipment, places for individual and group exploration of art, science, math and reading. There are places for active dramatic play and quiet play. The high platforms provide perches from which children can view the action but be apart from it. Underneath the platforms are places where quiet and hidden play can take place. The inclusive classroom accommodates children with limited mobility by providing stepped ramps up to platforms. (Figure 112, 113)



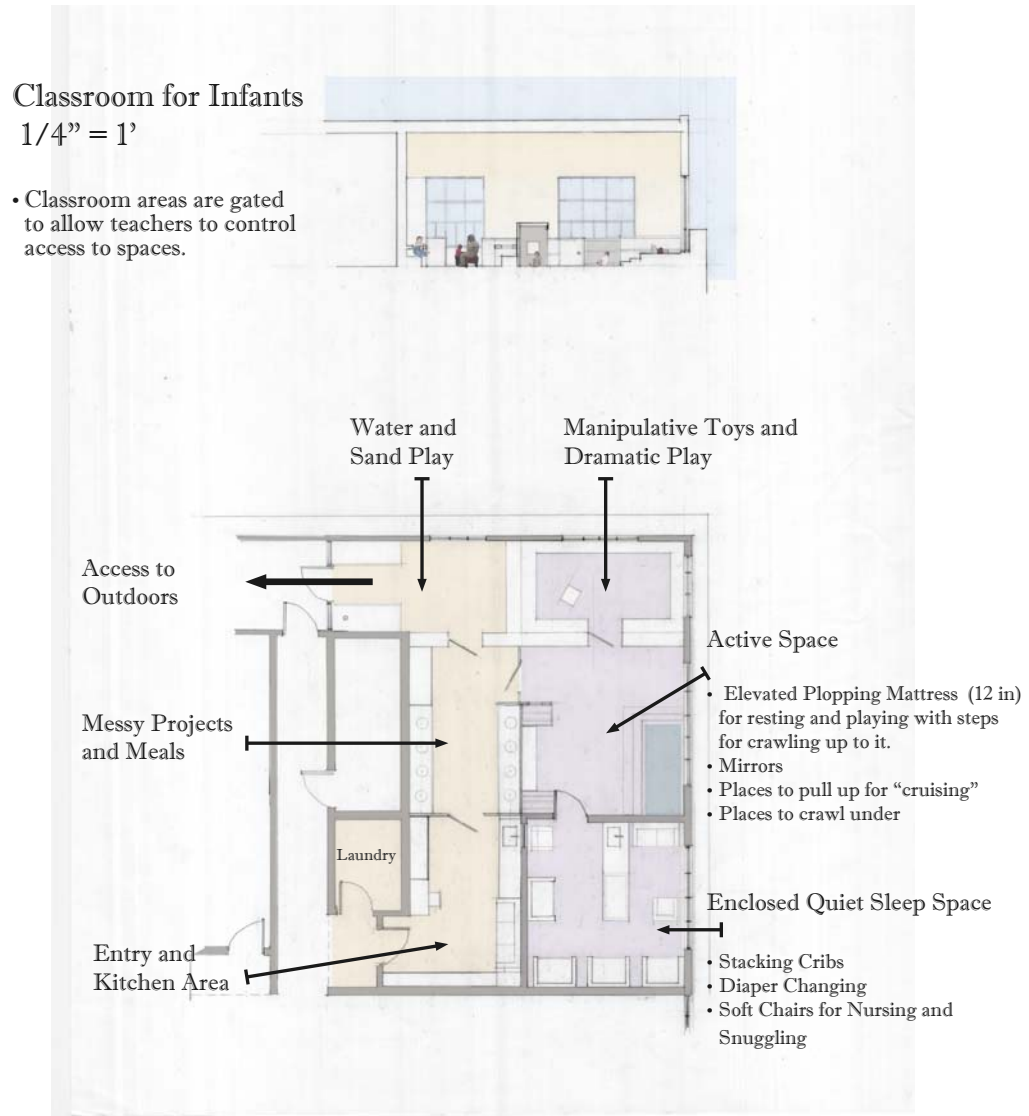
**Figure 112 Classroom for 3 and 4-year-olds. Stratton Treadway 2009**



**Figure 113 Pre-K classroom showing active side against garden and quiet side against interior wall. Notice high platforms with activity underneath. Stratton Treadway 2009.**

The classrooms for infants and toddlers have less of a distinction between active and quiet play zones because the children are not mobile as they will be in later months or years. They are also not very tall! Platforms for climbing are about 1' tall (instead of 5' for five-year-olds). Classrooms are designed to stimulate the children – with mirrors and toys at ground level, but must also be designed to facilitate adults taking care of the children. Diaper-changing, napping, feeding for infants and toddlers all are the

responsibility of the adults. As such, the classroom needs to include diaper-changing and meal preparation stations in places accessible for grownups. (Figure 114)



**Figure 114 Classroom for infants. Stratton Treadway 2009.**



Classroom for Toddlers

**Figure 115 Classroom for toddlers. Quiet side to the left and active side to the right. Stratton Treadway 2009.**

## Chapter 8: Critique and Response

### What is the relationship of this building to the landscape and the city?

By choosing to limit the building and landscape footprint to the “city grid” portion of the site and ringing it with a garden wall, has this thesis unnecessarily limited opportunities to engage the landscape? How can the building engage the landscape to the west? How can the western garden be developed to provide a place for intergenerational community play – a stated goal of the thesis?

The western wall was explored in depth throughout the design process, as a façade and as a sponsor of community space on the western side. Early designs explored the idea of the western wall as a bridge and the western garden as a place where an interior garden might spill through the building to the western side. (Figure 116)

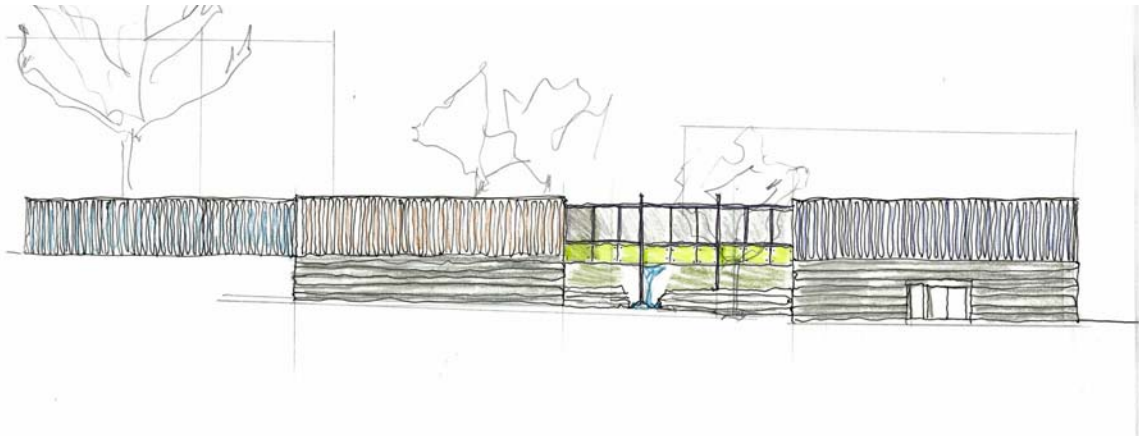
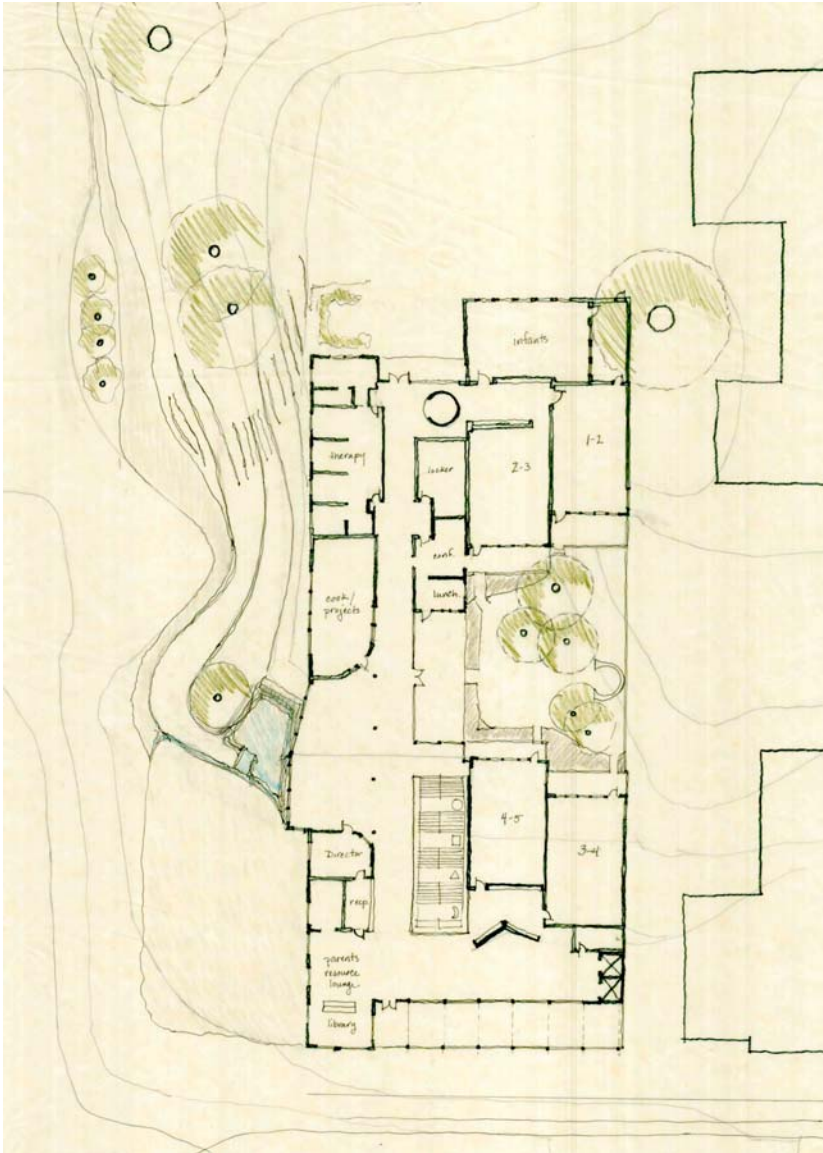
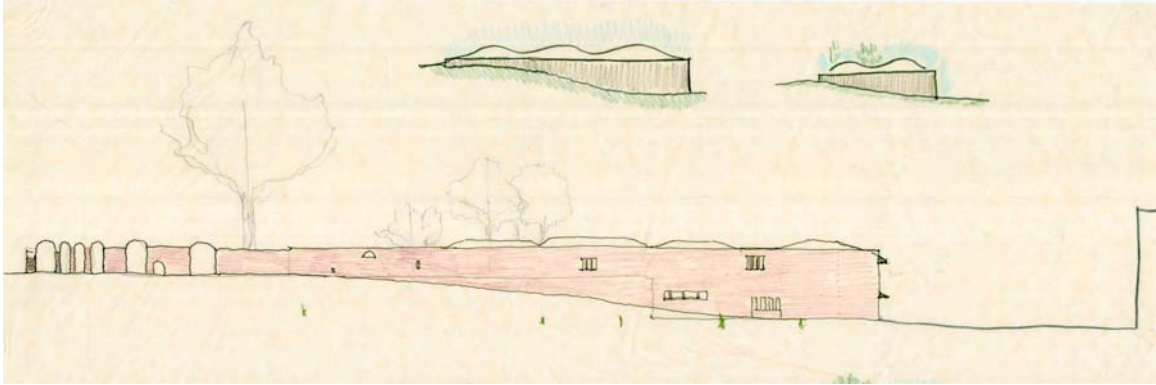


Figure 116 February version of the western wall as a bridge with piers. Stratton Treadway 2009.



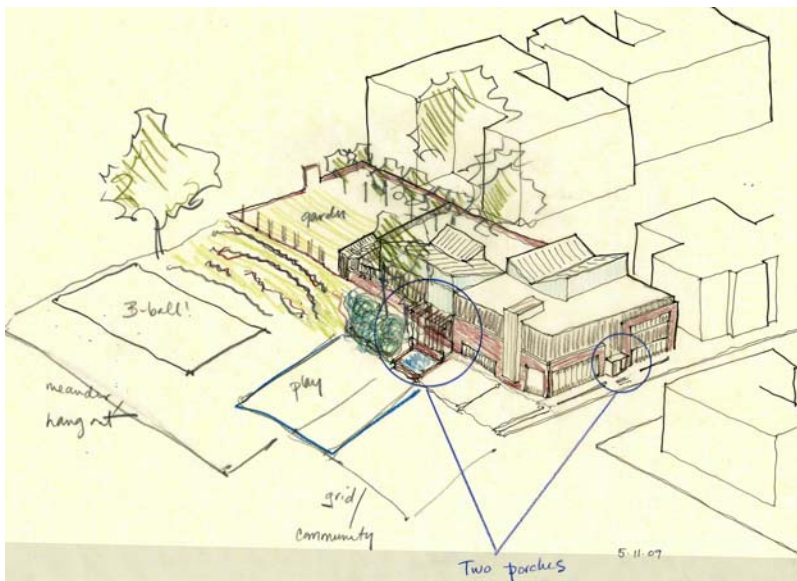
**Figure 117** Early plan of the project with the building (piazza) pushing out in to the landscape and sponsoring a community landscape to the west. Stratton Treadway 2009.

In the end, this thesis embraces the 300 ft long wall as the urban datum of the project – as representative of the urban grid of the city, but allows it to acknowledge the landscape by diving into it. (Figure 118)



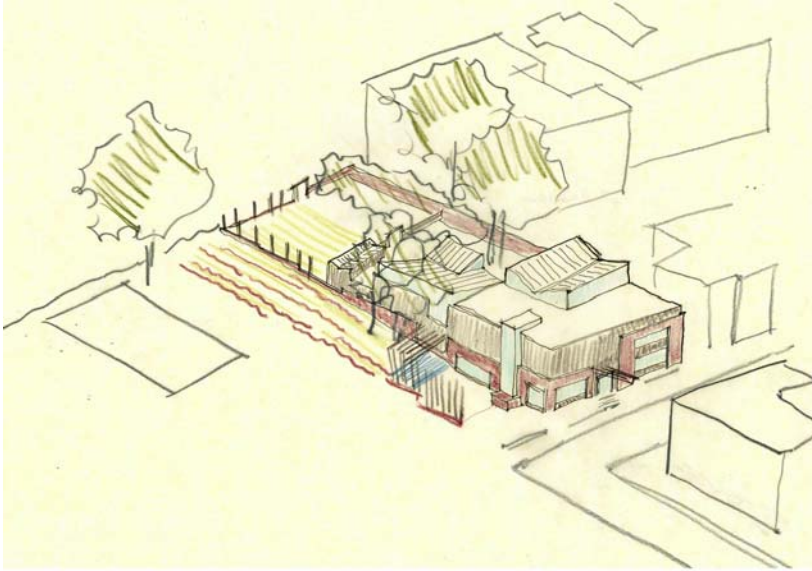
**Figure 118** Early version of the brick facade. Stratton Treadway 2009.

But the project, as presented at the A6 meeting did not fully develop the western landscape as a community space, nor did it integrate the building into that landscape. A series of later sketches explored options for integrating the building and the landscape. (Figure 119, 120)



**Figure 119** Sketch imagining western side of building as a community playspace and porch. Stratton Treadway 2009.





**Figure 120 Sketch showing community playspace and brick wall of garden alternating with the landscape as it rolls down the hill. Stratton Treadway 2009.**

In this subsequent iteration, the stair is turned perpendicular to the western garden and extends out into the landscape. (Figure 121) Its brick base could house a grill for use at community BBQ events. A large wooden screen provides a measure of enclosure and shade from the western sun for the community patio and shallow fountain in which the neighborhood children can play. In a final iteration of the western garden wall, the brick garden wall erodes at the back of the site to allow the community garden to roll down the hill creating low walls for seating to watch basketball or for children to walk along. The eastern side of the garden wall is raised to form a party wall-like condition to the neighboring apartment buildings and parking lot. By making the garden wall different on its two sides, the garden wall becomes responsive to the rolling landscape on one side and the urban grid on the other. (Figure 122)



**Figure 121 Revised site plan showing development of western landscape and new stair which engages the garden. Stratton Treadway 2009.**



West Elevation  
1/8" = 1'

**Figure 122 A western garden wall which responds to and engages the landscape. Stratton Treadway 2009.**

The pools of water in the western play space and the wooden screen wall are ways to extend the interior school garden to the exterior community garden. (Figure 123)



**Figure 123 Revised school plan showing the relationship between the stair and the western landscape and the two gardens. Stratton Treadway 2009.**

**What is the identity of this building? Whose building is it?**

Is this building a school – a place of learning? A daycare – a place of nurture and shelter to which access is controlled – or a community center – a place whose front door is open to all? Or is it a place that attempts to mix all three conditions? The obvious answer to the question, is that this thesis IS an attempt to mix all three functions because

of the ways in which the functions complement each other. Opening the building up to the community is an important part of the thesis. Providing a place for senior citizens not only makes a physical place for them, but it invites them into the life of the children upstairs if they want to be a part of it. Seniors can read and garden with older children; cuddle and coo with the infants and toddlers. Access to the upstairs is controlled, leaving the ground floor open to the community.

As for the question of school or daycare -- a daycare connotes nurture and play. A school connotes bringing children to the world of experiences and learning. This thesis, again, attempts to accommodate both. By elevating the facilities for children, their space is protected. But, by opening the classrooms to the garden -- in which children are invited to experience the world -- the changing seasons, the growing garden, the experience of the weather, are all there to be experienced. Since children learn by the experiences gained through their five senses rather than through instruction, learning is accomplished in a play environment.

But what should the image of the building be? How welcoming to the community? How revealing of what goes on inside? There is an inherent tension -- perhaps unresolved in this iteration of the project -- in whether to open this building to the community, secure it in order to secure the children, or proclaim it as a playful place. The Evarts Street façade, facing the community, is the place where this is revealed. A new iteration of the façade (Figure 125) makes a domestic scale front porch (as was explored earlier in the design process -- Figure 124), and makes a place for a banner or mural which can make the building part of the community. On this façade, it is clear that

the brick wall is higher on the east side towards the city than on the west side towards the landscape.

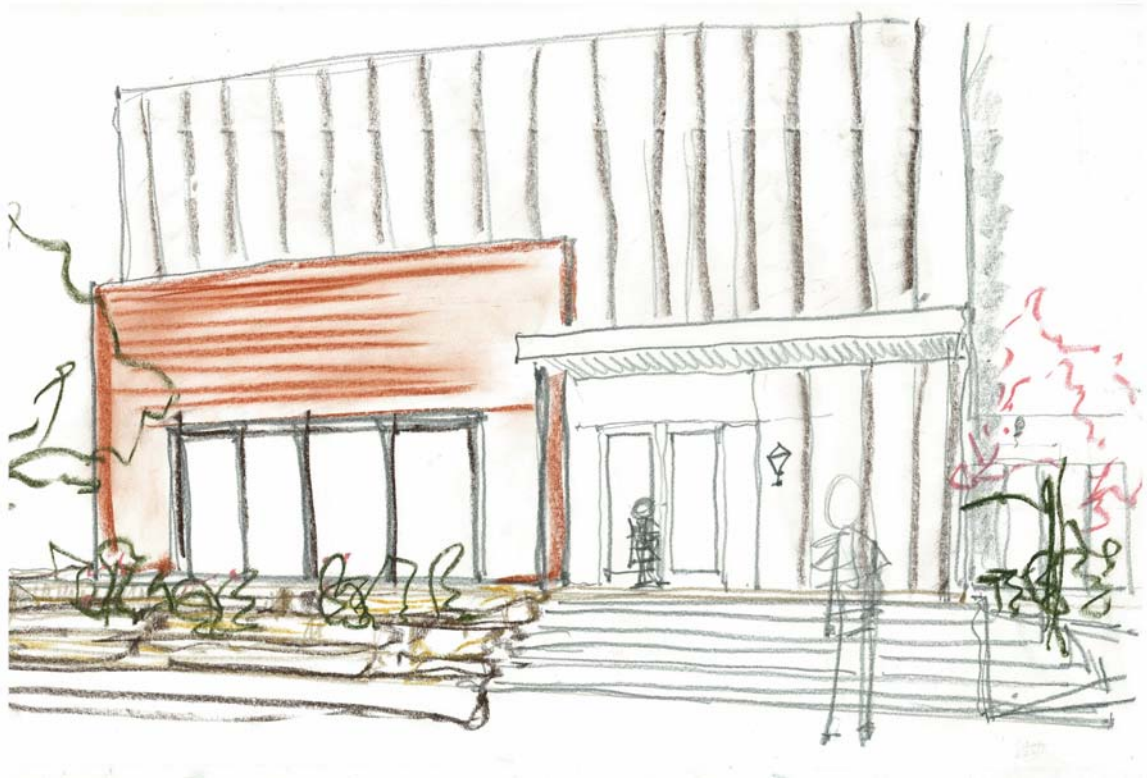


Figure 124 Earlier iteration of entry showing a domestic scale porch. Stratton Treadway 2009.



Figure 125 Revised Evarts Street facade. Stratton Treadway 2009.

This conundrum of image and use is also revealed in the way the entry sequence of the school overlaps (or doesn't) with the entry sequence for the community. In the ground floor plan presented at the A6 meeting, the entry for the school was segregated in a core in the center-front of the building which not only isolated the stair from the western garden (discussed above) but isolated the children and families away from the living room which was intended to be the “mixing place” to engage community members and families coming with their children to the daycare facility.

A new iteration of the ground floor (Figure 126) clarifies the entry circulation zone, clearly including the living room and stair in the same eddy of space. Additionally, the dining room now opens out into the community patio space to allow community events to flow between the kitchen and dining room in the building and patio outside.



**Figure 126 Revised ground floor plan. Stratton Treadway 2009.**

## **Chapter 9: Concluding Remarks**

The goal of this design thesis was to include. To include the community in the life of the child. To include children with special needs in a classroom with their “typically developing” peers. To include the children in the garden. To include the garden in the school. Not only do we remove stigma from difference when we include, but we enrich all lives in understanding and experience.

Being inclusive of children with special needs meant few changes to the design of the building and grounds – thanks in part to the American with Disabilities Act (ADA) which already mandates many important accommodations. Making sure all climbing equipment had stepped ramps for ease of climbing and that all doors had a glazed panel so that children with difficulty hearing could see what was going on on the other side, was not difficult. Indeed, it was the consensus of the teachers and administrators in the classrooms visited by the author, that children with special needs are easily accommodated in a classroom that is designed well around the rituals, routines, and experiences important to all children. And it was around those routines and experiences that this project was ultimately designed.

Wrestling with issues of identity, security and access are important for this new building type and will be even more critical if this model is ever to be built. But if these issues can be resolved successfully, this program of nurturing and healing and feeding a child within a community which itself is nurtured and healed and feed, can serve as a model for others.

Of course, social problems cannot be solved with a building or landscape alone. It would be impossible for such a program to succeed without the caring teaching and

administrative staff, whom this author encountered on every school and classroom visit. Especially for children with special needs, the school and community support system must be there for the child and the family. And funding sources must be there to support such schools. But by creating a pre-school nested within the community which cares for all of its children, it is hoped that this project can serve as a model for such facilities in other communities. Indeed, the more children who can be helped to thrive and made to wonder and play and explore as early in life as possible, the better off we are as a society.



## **Bibliography**

Aizenman, N. C. "NE Residents Protest Closure of DC Day-care Center" March 23, 2009. *Washington Post*.

Bachelard, Gaston. The Poetics of Space. Published originally in French in 1958. Beacon Press, Boston, 1969.

Bengtsson, Arvid. Adventure Playgrounds . Praeger Publishers, New York 1972.

Brower, Sidney. Design in Familiar Places: What Makes Home Environments Look Good. Praeger, New York. 1988.

Cooper Marcus. Healing Gardens: Therapeutic benefits and design recommendations.

Couturier, M.A. Sacred Art Menil Foundation. University of Texas Press, Austin, 1983.

Day, Christopher. Places of the Soul: Architecture and Environmental Design as a Healing Art. Architectural Press, 2004.

Day, Christopher. Environments for Children. Architectural Press, 2007.

Dudek, Mark. Children's Spaces. Elsevier, New York, New York. 2005.

Dudek, Mark. Kindergarten Architecture: Space for the Imagination. Second Edition. Spon Press, London. 2000.

Dudek, Mark. Schools and Kindertartens: A Design Manual. Birkhauser Verlag, Boston, 2007.

Friedberg, M. Paul. Play and Interplay: A Manifesto for New Design in Urban Recreational Development. 1970

Friedberg, M. Paul. Playgrounds for City Children. Association for Childhood Education International, Washington, DC. 1969.

Hood, Walter. Urban Diaries.

Jacobs, Jane. The Death and Life of Great American Cities. The Modern Library, New York, New York. 1961.

Louv, Richard. Last Child in the Woods: Saving Our Children from Nature-Deficit Disorder. Algonquin Books of Chapel Hill North Carolina, 2005.

Nabhan, Gary Paul and Stephen Trimble. The Geography of Childhood: Why Children Need Wild Places. Beacon Press, Boston. 1994.

Nair, Prakash and Fielding, Randall. The Language of School Design: Design Patterns for the 21<sup>st</sup> Century. DesignShare 2005.

Olds, Anita Rui. Child Care Design Guide. McGraw Hill, New York. 2001.

Perkins and Will Architects. "Early Childhood Education Facilities." Time-Saver Standards for Building Types.

Ruth, Linda Cain. Design Standards for Children's Environments. (Time-Saver). McGraw Hill, New York. 2000.

Sanoff, Henry. School Design. Van Nostrand Reinhold, New York. 1994.

Solomon, Susan G. American Playgrounds: Revitalizing Community Space. University Press of New England, Hanover 2005.

Aldo van Eyck: The Playgrounds in the City. Stedelijk Museum Amsterdam NAI Publishers Rotterdam, 2002.