

ABSTRACT

Title of Document: Transforming the Rustbelt: Adaptive reuse of industrial buildings in the context of the Rust Belt.

Luke James Petrusic, M Arch Candidate 2015

Directed By: Prof Peter Noonan, AIA, LEED BD+C Professor of the Practice, School of Architecture, Planning & Preservation

This project seeks to address the problem of the future of industrial ruins / cities within the larger context of the US rust belt. Many of these Rust Belt cities face challenges of decaying infrastructure, overburdened social services, population loss, increased crime, and pronounced civil decline. This thesis seeks to find a program or architectural intervention that capitalizes on abandoned industrial buildings that can be seen as catalysts for revitalization.

The city of Johnstown will be examined as it has many of the key traits of a rust belt city. The architectural response to these set of problems must manifest at the regional, city, and site scale to address the question of whether such interventions in Johnstown can serve as models or catalysts for new industries, alternate uses, identity, social structure, improve quality of life, and an embodiment community ideals? The industrial ruins in rust belt cities are the embodiment of political decisions, social circumstances, economic factors and unique architectural features. Any intervention

must address these embodied forces in order to create a viable transformation and to make Johnstown a showcase of what these places could be.

.

TRANSFORMING THE RUST BELT: ADAPTIVE RE_USE OF INDUSTRIAL
BUILDINGS IN THE CONTEXT OF THE RUST BELT.

By

Luke James Petrusic.

Thesis submitted to the Faculty of the Graduate School of the
University of Maryland, College Park, in partial fulfillment
of the requirements for the degree of
Masters of Architecture
2015

Advisory Committee:

Professor Peter Noonan, Chair, Professor of the Practice

Steven Hurtt, Professor

Garth Rockcastle, FAIA, Professor

© Copyright by
Luke James Petrusic
2015

Preface

Located in Johnstown PA, are the Cambria Iron works and subsidiary structures. These buildings take up a footprint almost that of the entire downtown. Their physical size is a testament to the scale and influence that the manufacturing industry had on Johnstown as well as other similar cities in what is now known as the Rust Belt. After the decline of industry, these cities began to face multiple problems including population loss, decay of infrastructure, and increased crime.

In order to address the problems that face rust belt cities face, solutions must address these problems at the regional, city, as well as the architectural scale. They will require “extensive retooling, not just economically but in terms of their built environment, cultural character, political economy, and demographic mix.”¹

Larger cities with more resources such as Pittsburgh and smaller cities such as Allentown Pennsylvania have more diversified economies, and political clout that has helped them cope with the economic transformation of the late 20th century. “The capacity of small cities to remake themselves in light of these economic changes...is considerably more limited¹” (5).

Despite this, there have been strategies outlined over the past decade for the renewal of decaying industrial cities. They call for the cities to first engage in a planning process in order to determine what assets they have and can build upon. They must next rehabilitate infrastructure, meaning the rehabilitation and repurposing of abandoned properties to restore local tax base. This can be accomplished by

¹ Connolly, James J. *After the Factory: Reinventing America's Industrial Small Cities*. Lanham: Lexington Books, 2012.

developing cultural amenities and educational opportunities, helping workers re-tool for a local economy, and ultimately improve the quality of life. One of the most difficult but essential step is to rehabilitate the community's image, not only in the eyes of the residents but also the community.

Johnstown is a good place to examine the potential for each of these strategies. It has the social and physical characteristics of a Rust Belt City and it has features that are unique that will inform the scale and form of any architectural and planning interventions that can give the city a new image. "Given their assets, the moment is ripe for the revival of older industrial urban economies²". In order to determine the most appropriate response for Johnstown, places similar in geography, social and political setting, as well as size will be examined to extract what lessons can be applied. Also, prior planning and redevelopment efforts by Johnstown will be evaluated for their successes, failures, and will be compared to similar efforts made in other cities.

Johnstown, amongst others like it in the Rust Belt, awaits transformation, new purpose, new life and new identity. Can Rust Belt Cities be more than just reminders of a once prosperous past? In essence, can places that have been successful serve as models for others, or can strategies adapted from Johnstown serve as a model for other cities?

² Fox, Radhika, and Miriam Lute. *To Be Strong Again: Renewing the Promise in Smaller Industrial Cities*. Oakland, CA: Policy Link, 2008.

Foreword

If needed.

Dedication

For my Mom and Dad.

Acknowledgements

Table of Contents

Preface.....	ii
Foreword.....	v
Dedication.....	vi
Acknowledgements.....	vii
Table of Contents.....	viii
List of Figures.....	1
Overview.....	3
Introduction.....	3
General Problems.....	7
De-industrialization and removal of industry (Functional Shift).....	7
Chapter 2: Johnstown.....	9
Geography.....	9
River systems.....	9
Natural Resources.....	9
History.....	13
Town.....	13
Steel.....	13
Floods.....	17
Flood Remediation Efforts.....	20
Paternalism.....	21
Chapter 3: Past Efforts from Johnstown.....	23
Johnstown Redevelopment Authority (JRA) - 1949.....	23
Overview.....	23
Timeline of Projects.....	24
Cambria city Renewal 1953-1967.....	24
Cambria Iron Works 1998-.....	24
Johnstown Renaissance Project 1988-2004.....	26
Greater Johnstown Technology Park 2004-2008.....	27
Johnstown Area Heritage Association - 1971.....	28
Overview.....	28
Timeline of Projects.....	28
Johnstown Flood Museum 1973.....	29
National Folk Festival 1990 / AmeriServ Flood City Music Festival.....	29
Frank & Sylvia Pasquerilla Heritage Discovery Center 2001.....	30
Peoples Natural Gas Park – 2011-2012.....	31
Johnstown Heritage Development Plan - 1991.....	31
Overview.....	31
Organization.....	33
Preservation Management Strategy.....	34
The Vision of a New Johnstown.....	35
Chapter 4: Emerging Solutions.....	37
Introduction.....	37

Brownfield Remediation.....	37
Introduction.....	37
Principles of brownfield Regeneration	38
How does the brownfield remediation process work?.....	39
Small City Revitalization.....	40
Turning Around Downtown: Twelve Steps to Revitalization	40
Welcome Back Downtown: A Guide to Revitalizing Pennsylvania’s Small Downtowns	42
Rightsizing cities – The City after Abandonment / Shrinkage vs Renewal – Design After Decline	43
Theories and Philosophies	46
Implementation	46
Precedents	47
Improving Housing Stock.....	48
Introduction.....	48
Confronting Urban Population Decline	50
Chapter 5: Demonstration (Thesis Project).....	53
My Strategy.....	53
City Scale strategies.....	54
Urban planning to reinforce original parti of downtown	54
Integration of steel mill into city fabric	55
Neighborhood Scale.....	58
New storm water management strategy	61
Building Scale.....	66
Detail Scale	71
Chapter 6: Conclusions.....	76
Public Presentation.....	76
Closing Remarks.....	77
Bibliography	78

List of Figures

Figure 1: Map showing cities that fall within the geographical region known as the Rust Belt and Coal Belt. Image by author.	3
Figure 2: Map showing connection of rail lines between bust belt cities. Image by author.	4
Figure 3: Map of Pennsylvania Canal and Portage Railroad line c. 1850. http://jaha.org/edu/flood/why/img/map_gallery/index.html	5
Figure 4: Map Showing Change in number of manufacturing jobs from 1954-2002. Image by author.	6
Figure 5: Map showing population change as a percentage in Rust Belt cities from 2000-2012. Image by Author.	8
Figure 6: Map showing Great Lakes shipping lanes and the type of material being shipped. http://geo.msu.edu/extra/geogmich/iron_ore__taconite.html	10
Figure 7: Map of Johnstown city extents, river systems, and roadways. Image by author.	11
Figure 8: Map showing topography contours at center of city. Image by author.	12
Figure 9: This image shows the extent of the destruction caused by the 1889 Flood. http://www.jaha.org/FloodMuseum/history.html	17
Figure 10: Map showing flood plane in Johnstown and River System. Image by author	18
Figure 11: Picture showing the natural edge of the rivers in Johnstown. http://www.toledoblade.com/image/2007/05/31/800x_b1_cCM_z/Revisiting-a-flood-116-years-before-levees-gave-way-in-New-Orleans-a-rushing-wall-of-water-obliterated-Johnstown-Pa-3.jpg	20
Figure 12: After several devastating floods, the rivers in Johnstown were gouged widened and lined with concrete to make the city ‘flood free’. Image by author.	21
Figure 13: An aerial view of Cambria Iron lower works with various buildings labeled. http://www.epa.gov/reg3hwmd/bf-lr/newsletter/2007-Summer/cambria.html	25
Figure 14: image of Frank J. Pasquerilla Conference Center. http://www.johnstown-redevelopment.org/jtownrenaissance.htm	26
Figure 15: Cambria County War Memorial Arena. http://www.warmemorialarena.com/	26
Figure 16: Greater Johnstown Technology Park. http://www.lrkimball.com/Federal_Architecture_Facility_Design_and_DB.aspx	27
Figure 17: Interior of Flood Museum. http://www.jaha.org/FloodMuseum/oklahoma.html	29
Figure 18: Johnstown Flood Museum. http://bachmantours.com/Home.htm	29
Figure 19: Flood City Music Festival Logo. http://www.musicfestivaljunkies.com/festivals/flood-city-music-festival-2013/	29
Figure 20: Exterior of Discovery Center. Image by author.	30
Figure 21: Interior exhibit of Discovery Center. http://www.jaha.org/DiscoveryCenter/virtualtour.html	30
Figure 22: Entrance of Peoples Natural Gas Park. Image by author.	31

Figure 23: Population Change in Rust Belt Cities 2000-2012. Image by author.	48
Figure 24: Typical Abandoned housing seen in Downtown Johnstown. Image by author.	49
Figure 25: Aerial image of downtown Johnstown 2014. Google Earth.	50
Figure 26: Aerial image of Downtown Johnstown in the 1950's (http://www.jaha.org/edu/flood/rebuild/img/panoramas/index.html#1920a).....	50
Figure 27: diagrams illustrating methodology to improve urban quality of Downtown.	54
Figure 28: Aerial of the Almono Steel mill site. http://www.popcitymedia.com/features/development102214.aspx	56
Figure 29: Image of landschaftspark. http://www.popcitymedia.com/features/development102214.aspx	57
Figure 30: Image of the Plant at Kyle. http://www.theplantatkyle.com/full/index.html	58
Figure 31: schematic plan design that propose new blocks, new building uses and interrogate the edge condition of the Gautier steel mill and the river. Image by author.	Error! Bookmark not defined.
Figure 32: Schematic designs of the Gautier steel mill continued. Image by author.	60
Figure 33: Section of proposed green street detail. Image by author.	62
Figure 34: location for design of green streets. Image by author.	63
Figure 35: Aerial image of new park space. Image by author.	63
Figure 36: Storm water park flooded to reveal the shape of the canal basin. Image by author.	64
Figure 37: New edge of river adjacent to site. Image by author.....	65
Figure 38: Section perspective illustrating experiential nature of new storm water management riparian edge. Image by author.....	65
Figure 39: Map showing old uses of different city blocks. Image by author.	67
Figure 40: New proposed building uses for new Gautier steel mill buildings. Image by author.	68
Figure 41: Drawings illustrating precedent insertions into existing Gautier steel mill strucutre. Image by author.	69
Figure 42: Matrix showing variance of structural expression. Image by author.	72
Figure 43: diagram illusreatign surfaces to be clad in brick. Image by author.....	74
Figure 44: Brick elevation detail. Image by author.	74
Figure 45: Diagram illustrating facade surfaces that are glazed. Image by author.....	75
Figure 46: Elevation Detail of Glazed Facade. Image by author.....	75

Chapter 1: Rust Belt

Overview

Introduction

Johnstown is one among many US cities now described as belonging to the “Rust Belt”. This phrase that became popular in the 1980’s. It is used to define the postindustrial region straddling the Northeastern United States including New York,

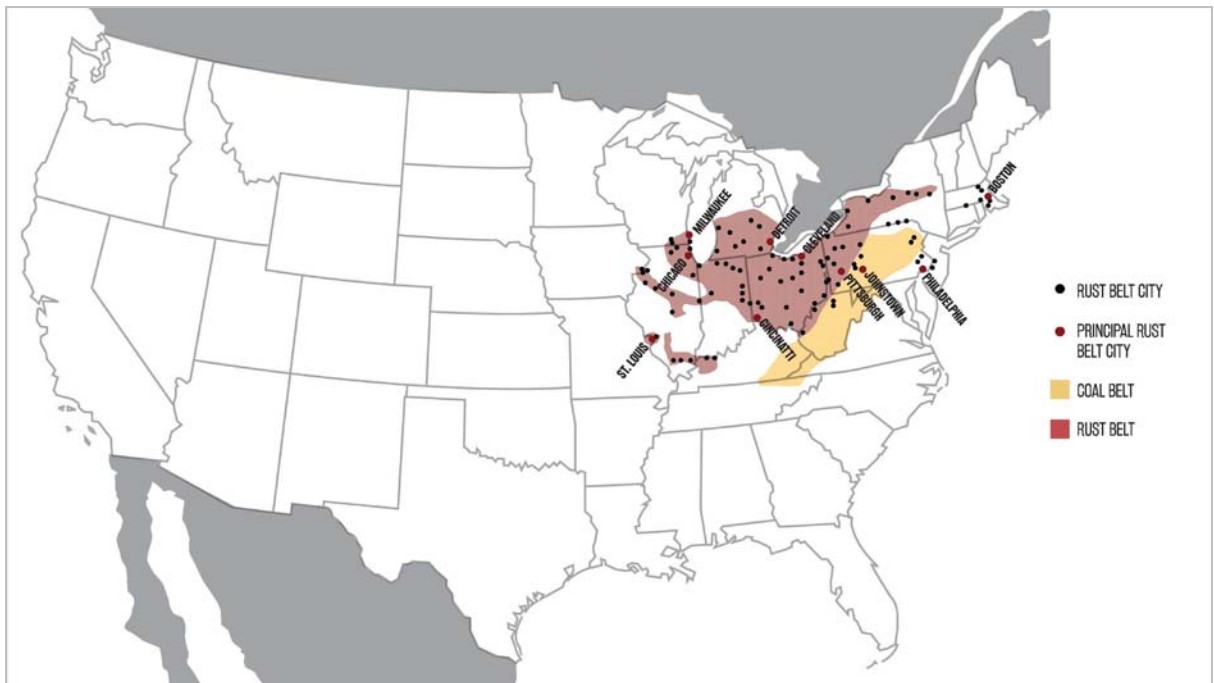

Figure 1: Map showing cities that fall within the geographical region known as the Rust Belt and Coal Belt. Image by author.

Pennsylvania, West Virginia, Ohio, Indiana, Michigan, Illinois, and

Wisconsin as seen in Figure 1.1. The term Rust Belt is not tied to these states or a specific geographical region, but is a term applied to any place that has a particular

set of economic and social conditions. The extent to which we can describe a community as a rust belt city depends on the extent of influence industrial manufacturing played in its economy in the past including current living standards.

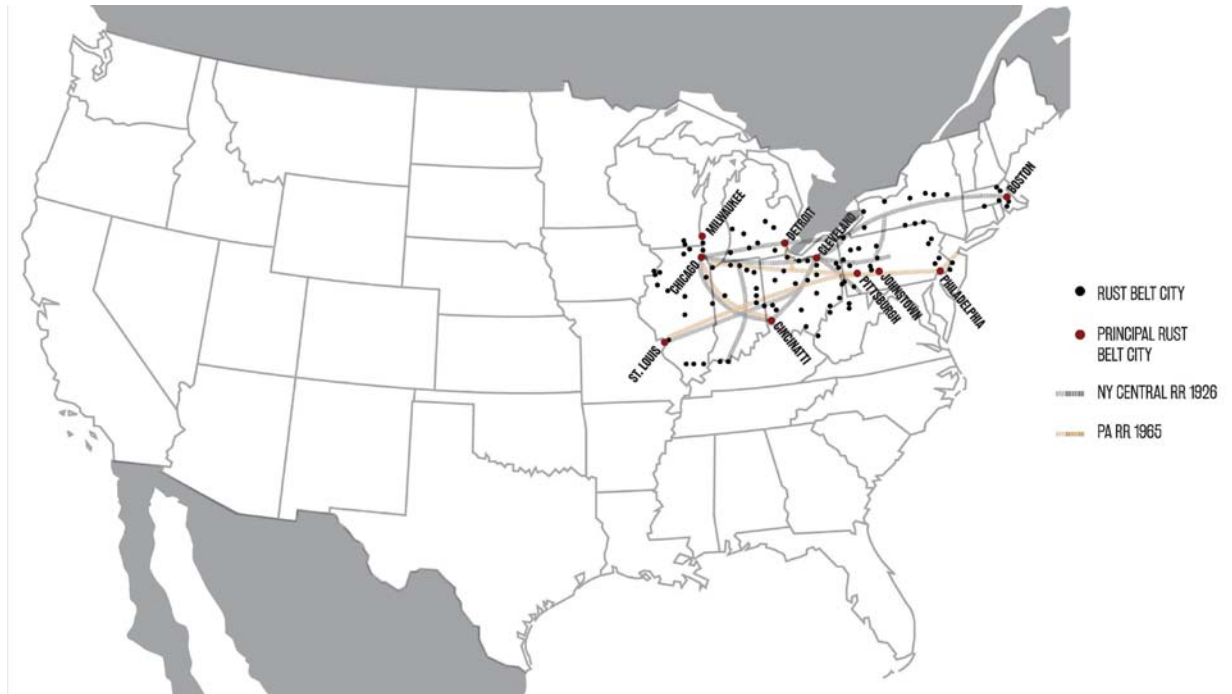

Figure 2: Map showing connection of rail lines between bust belt cities. Image by author.

To understand the Growth of the Rustbelt, we must first understand what it was

before it came to be known as the Rust Belt. These areas were originally a part of the region known as the ‘Factory” or “Steel” Belt where major manufacturing took place.

These were places where manufacturing industries were often the soul or preliminary economic driver of a town or region. The growth of cities within the rust belt was influenced by their proximity to transportation and mineral resources needed for processing raw material and power sources. In the US the Great Lakes Waterways, paved roads, water canals, railroads and related transportation took iron ore from Minnesota and Upper Michigan and transported it to towns that had access to coal mined from the Appalachian Mountains that could be used in furnaces to refine the

iron and make steel. During WWII this area reached its peak in population as well as industrial output. All of the iron ore that was refined to make steel for the war effort was mined from Michigan and Minnesota. These booming industrial towns attracted large immigrant populations from places such as Hungary, Poland, Slovakia, and Russia which in turn contributed to the cultural heritage of many of these towns.

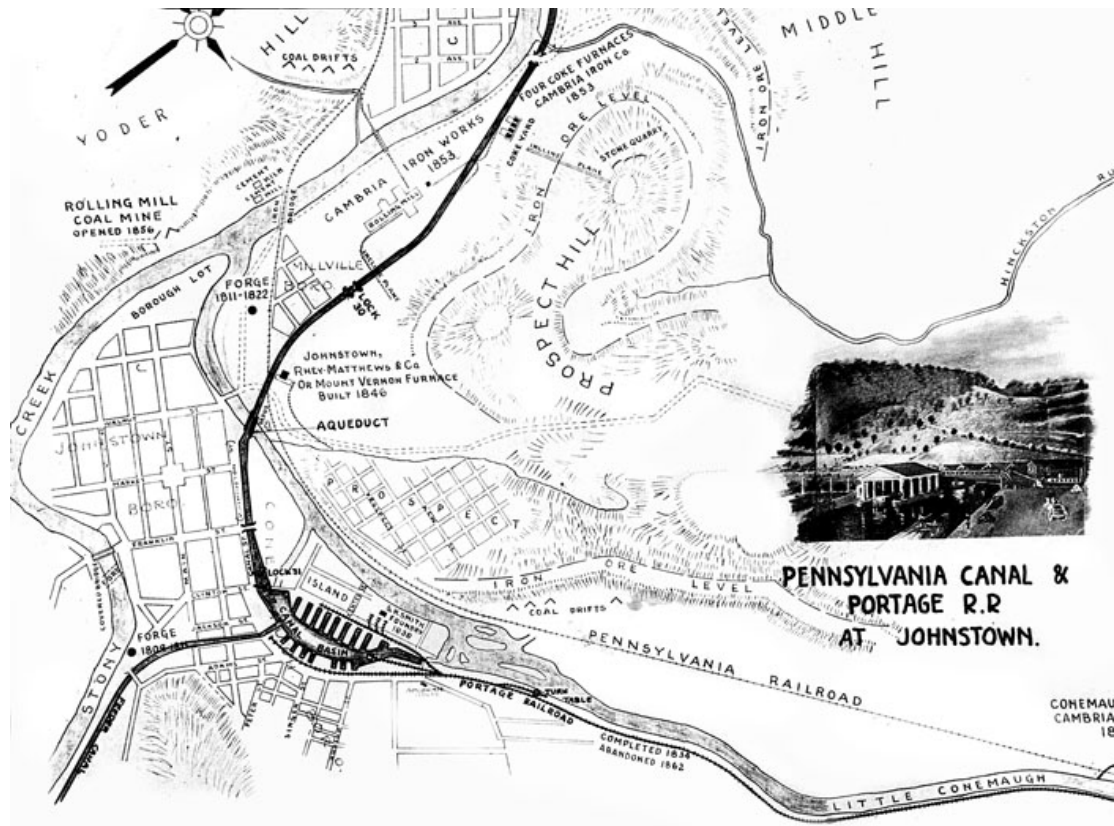

Figure 3: Map of Pennsylvania Canal and Portage Railroad line c. 1850.
http://jaha.org/edu/flood/why/img/map_gallery/index.html

Multiple reasons for the decline of Rust Belt cities have been described, usually related to a series of events that took place beginning in the 1960s. Reasons for the decline following the boom of industrial output fueled by WWII, there and onset of outward migration of residents to newer suburban communities include a general

decline in manufacturing as a role in the US economy.³ The unemployment rate in the manufacturing sector declined by 32.9% between 1969 and 1966 within the north east region of the US. However, it is important to recognize that American manufacturing output did not necessarily decline during the second half of the 20th century. Instead, technological innovations created efficiencies that required less physical labor in order to increase output levels. These efficiencies or, “improvements in communication and transportation, combined with increased costs for labor and land, encouraged [steel] firms to relocate plants to the southern and western US⁴” (4). The decline of the Rust Belts towns was not as much the result of a downturn in manufacturing as a result of a structural shift in the location and procedures of manufacturing steel. This is illustrated in Fig 1.3. This map shows that there was a

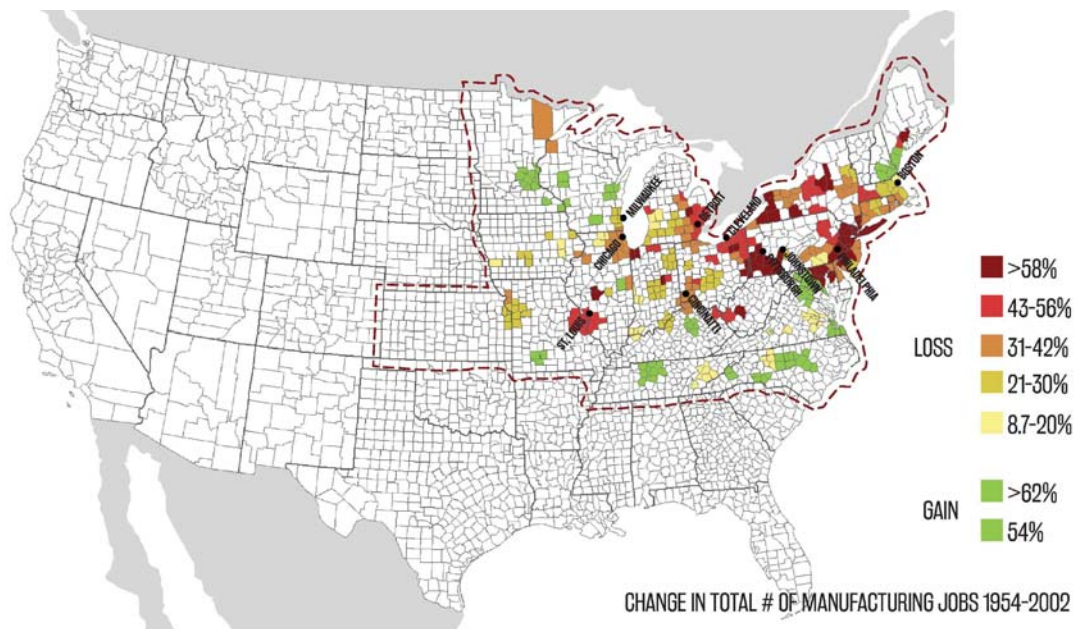

Figure 4: Map Showing Change in number of manufacturing jobs from 1954-2002. Image by author.

³ "Rust Belt." Wikipedia. Accessed December 13, 2014. http://en.wikipedia.org/wiki/Rust_Belt.

⁴ Connolly, James J. *After the Factory: Reinventing America's Industrial Small Cities*. Lanham: Lexington Books, 2012.

significant loss of manufacturing jobs in the North East region of the United States. Also, during this same time period there was a significant increase in manufacturing jobs in the Southern and Western United States. This illustrates the point that the total number of manufacturing jobs did not decline but simply shifted in their geographical location.

General Problems

De-industrialization and removal of industry (Functional Shift)

Of the many issues associated with the decline of industry within the rust belt, a political scientist and economist, Francis Fukuyama, refers to the results of this structural shift in his work *The Great Disruption: Human Nature and the Reconstruction of Social Order*. In this work he examines the shift from the manufacturing age to the information age and the effects it had. Some of these results are changes in the fabric of our moral traditions. He goes on to describe that the decline is readily measurable in statistics on crime, fatherless children, broken trust, reduced opportunities for and outcomes from education, and the like⁵. Other problems to Rust Belt cities include a diminished tax base, decaying infrastructure, overburdened social services, increased crime, poorly educated work force, underfunded schools, and population loss or a phenomenon known as the ‘brain

⁵ Fukuyama, Francis. *The Great Disruption: Human Nature and the Reconstitution of Social Order*. New York: Free Press, 1999.

drain”.

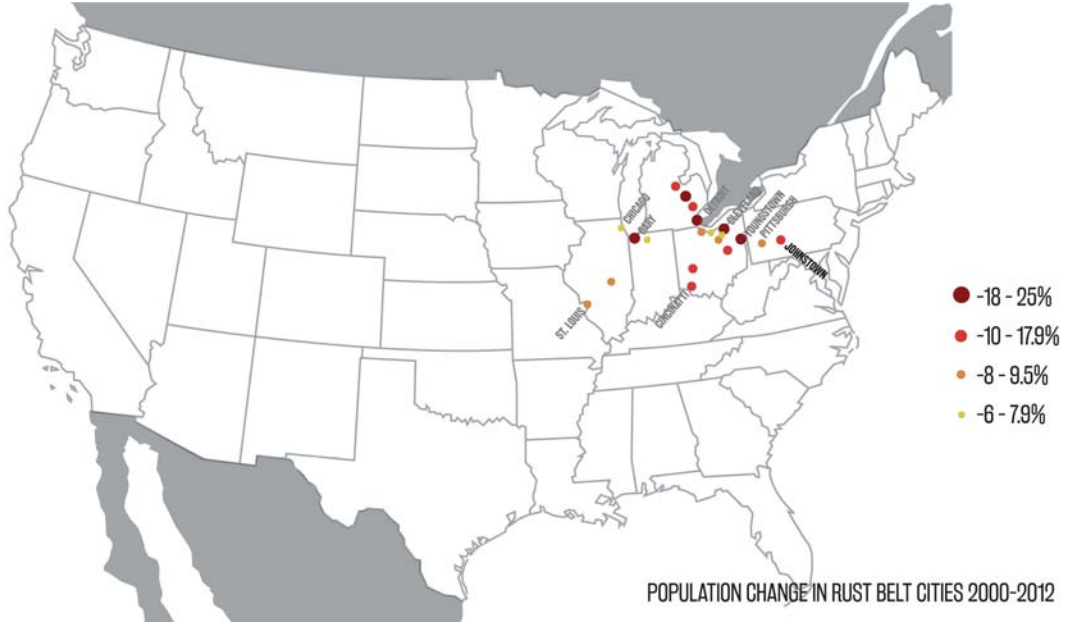

Figure 5: Map showing population change as a percentage in Rust Belt cities from 2000-2012. Image by Author.

Much of the public attention on urban decline in the US has focused on major cities and has tended to obfuscate the same phenomenon that is occurring in smaller less noted cities⁶. Many of these smaller cities grew because of a single industry, including Johnstown. As industry declined so did the cities⁶. Figure 1.4 shows Population change in Rust Belt cities from 2000-2012. Not only are larger cities such as Detroit and Cleveland declining but Johnstown’s population also declined significantly in this time period.

⁶ Burchell, Robert W., and David Listokin. *The Adaptive Reuse Handbook: Procedures to Inventory, Control, Manage, and Reemploy Surplus Municipal Properties*. New Brunswick, N.J.: Rutgers University, Center for Urban Policy Research, 1981.

Chapter 2: Johnstown

Geography

River systems

The city of Johnstown is located at the Laurel Highlands section of the Allegheny Mountains. It sits in a steep Y shaped valley at the convergence of three river valleys; the Stony Creek, the Conemaugh, and the Little Conemaugh. “This location and topography have provided both the source and the limits of Johnstown’s growth⁷” (1) Somewhat ironically the town initially was isolated because of topographic and geographic constraints even though it rolled most of the iron rails that opened up the nation for expansion throughout the country. The river systems initially served as the driving economic force that lead Johnstown to become one of the most important sites on the Pennsylvania Main Line Canal connecting Philadelphia to Pittsburgh. Here iron bars were shipped down the Conemaugh to Pittsburgh. “According to the canal commissioners reports in 1839 Johnstown secured more canal income than any other town in the system⁵ (9).

Natural Resources

⁷ Wallace, Kim E. *The Character of a Steel Mill City: Four Historic Neighborhoods of Johnstown, Pennsylvania*. Washington, D.C.: Historic American Buildings Survey/Historic American Engineering Record, National Park Service, 1989.

The combination of both transportation and natural resources supported the rapid growth of a local iron and steel making industry. The growth of cities within the rust belt was influenced by their proximity to transportation and mineral resources needed for processing raw material. In the US the Great Lakes Waterways, paved roads, water canals, and railroads transported iron ore from Minnesota and Upper Michigan to towns that had access to coal mined from the Appalachian Mountains. Johnstown was the perfect place for the processing of iron ore that was mined up north because



Figure 6: Map showing Great Lakes shipping lanes and the type of material being shipped. http://geo.msu.edu/extra/geogmich/iron_ore_taconite.html of the ore deposits in the hills surrounding the town.



Figure 7: Map of Johnstown city extents, river systems, and roadways. Image by author.



Figure 8: Map showing topography contours at center of city. Image by author.

History

Town

Johnstown Pennsylvania was originally laid out and founded as a speculative venture by Joseph Schantz (Johns). It had a meager population of 200 in 1821 and was incorporated in 1831⁸. In 1828 Johnstown was selected as one of the most important sites that would be on the interior length of the proposed Pennsylvania Main Line Canal that would link Philadelphia to Pittsburgh.

The three main themes of the town's history can be defined in terms of the growth and decline of its steel industry, as was typical of many cities within the rust belt; the history of floods that lead to many stigmas and image issues for the town; and the political leadership of the town as it relates to decisions about public policy and services.

Steel

The history of the steel industry at Johnstown begins with the Canals. The Canals that connected to Johnstown were crucial before there were well established railroads. The access to the river gave Johnstown the ability to load "Juanita Iron" from the various furnaces along rivers leading into the town that was then packed onto barges and sent down the Conemaugh River to Pittsburgh. This had a great impact on the economy of Johnstown according to Wallace's *The Character of a Steel Mill City*. The author reflects on the impacts the canal system had on the town and its growth stating that

⁸ Wallace, Kim E. *The Character of a Steel Mill City: Four Historic Neighborhoods of Johnstown, Pennsylvania*. Washington, D.C.: Historic American Buildings Survey/Historic American Engineering Record, National Park Service, 1989.

“the direct connection to Pittsburgh and Philadelphia, and the spectacle of all sorts of passengers and cargo passing through gave Johnstown the inspiration and means to aspire to a less provincial life⁹” (9). During the success of the Canal systems in 1839, Johnstown earned more income than any other town on this system. However, this would soon change with the coming of the Pennsylvania Railroad in 1854.

The history of iron and steel within Johnstown is something that was not new to that region of Pennsylvania. The Pig Iron that was produced by the region’s many iron furnaces⁹ helped support Johnstown in the early canal era, and once the Allegheny Portage railroad opened, 5600 tons of iron passed through Johnstown annually.

Because the new rail system made it impossible for the canal system to compete, the state sold the canal system to the railroad for 7.5 million in 1857. Many of the towns that were solely dependent on the canal system failed and were abandoned. Johnstown was able to escape this fate largely due to its unique topography. The new railroad system in the town was easily incorporated by placing it adjacent to the canal that was worn into the topography by the Conemaugh River. It is likely that the Rail road acquired the canal so that it could have access to this right of way that was already at the appropriate gradient for the canal.

With the anticipation of the railroad in Johnstown, a businessman by the name of George S. King saw this as the ideal place to locate iron furnaces to produce rail for the growing Rail Roads across the nation. He would found the Cambria Iron company in 1852 after soliciting over \$1 million dollars in investment funds from

⁹ Wallace, Kim E. *The Character of a Steel Mill City: Four Historic Neighborhoods of Johnstown, Pennsylvania*. Washington, D.C.: Historic American Buildings Survey/Historic American Engineering Record, National Park Service, 1989.

partners in Boston and New York¹². This was also the same year that the railroad connection through Johnstown was completed¹⁰ (10). Johnstown not only grew because of the increased transportation afforded by the Railroad lines, but also directly contributed to the growth of the railroad itself.

What led to the iron making business in Johnstown can be attributed to its geographic location, not unlike many of the small towns that formed in the Steel / Manufacturing Belt before it came to be known as the Rust belt. George King, the creator of Cambria Iron, initiated the iron-making business after finding veins of ore in the hills that surrounded the town.

Even with advantages such as this, it was difficult to solicit the finances that were necessary to keep Cambria Iron solvent though it's first years of operation and went through several reorganizations. The company was sold to investors from Philadelphia and it was renamed the Wood, Morell and Company in 1855. After reverting back to Cambria Iron in 1862, "and with increasing demand for the Cambria Product...by the mid-1870's it had become one of the largest iron and steel works in the nation¹¹" (12). Its facilities expanded over 60 acres. To diversify the product line, Cambria Iron formed a partnership with the Gautier family out of Philadelphia who owned a steel products company. Gautier later would become a subsidiary of Cambria Iron.

¹⁰ Wallace, Kim E. *The Character of a Steel Mill City: Four Historic Neighborhoods of Johnstown, Pennsylvania*. Washington, D.C.: Historic American Buildings Survey/Historic American Engineering Record, National Park Service, 1989.

¹¹ Wallace, Kim E. *The Character of a Steel Mill City: Four Historic Neighborhoods of Johnstown, Pennsylvania*. Washington, D.C.: Historic American Buildings Survey/Historic American Engineering Record, National Park Service, 1989.

In 1898 there were concerns about the need for the company to expand and improve the facilities in Johnstown. There was consideration given to moving the works to a site on the Great Lakes, however, Cambria Iron was later reorganized as Cambria Steel Company and invested \$70 million dollars over the next 20 years to improve the facility and make additions. One such addition was the Franklin Works that was built between the boroughs of Franklin and East Conemaugh. The Rod and Wire Division was added to the other side of the Lower Works.

Half a century after the Rod and Wire Division opened, Cambria Steel was purchased by Midvale Steel and Ordinance Company of Philadelphia. Following the WWI steel industry boom, Midvale's earnings had diminished greatly and they sold all of their holdings to the Bethlehem Steel Corporation. Charles Schwab reorganized Bethlehem steel in 1904 and build a corporation to rival the largest steel conglomerated in the US. He invested nearly \$35 million dollars to improve the facilities in Johnstown, pledging to make the Cambria Steel Works "one of the greatest in the world"¹² (14).

Many factors lead to the downturn of industry in Johnstown. Changes in markets, technology, and transportation during the 20th century reduced Johnstown's advantage as an industrial center. It could not compete with cities such as Chicago, Pittsburgh, and Gary because of their advantageous location to receive raw materials. In the 1960's the US Steel industry had to compete with overseas competition, and Bethlehem failed to update the steel plants to keep pace with modernization. "Today the mills operate at a fraction of their former capacity, but Bethlehem Steel

¹² Wallace, Kim E. *The Character of a Steel Mill City: Four Historic Neighborhoods of Johnstown, Pennsylvania*. Washington, D.C.: Historic American Buildings Survey/Historic American Engineering Record, National Park Service, 1989.

Corporation continues to be an important presence in Johnstown as the city struggles to cope with the consequences of its history as a community tied to a single industry¹¹” (14).

Floods



Figure 9: This image shows the extent of the destruction caused by the 1889 Flood.
<http://www.jaha.org/FloodMuseum/history.html>

The rivers systems that once brought people and goods into the town along the canal system would also be the cause of the greatest catastrophes Johnstown would face. In 1889 the collapse of the south fork damn about 15 miles up the Little Conemaugh river North East of the city would let lose 20 million gallons of water destroying almost all of the downtown and take the lives of 2200 people. “Two subsequent floods in 1936 that took the lives of two dozen people and damaged 300 buildings ad well as in 1977 that caused extensive damage to the downtown and steel industry buildings, served to reinforce the city’s notoriety as “that place where there was a flood¹³” (25).

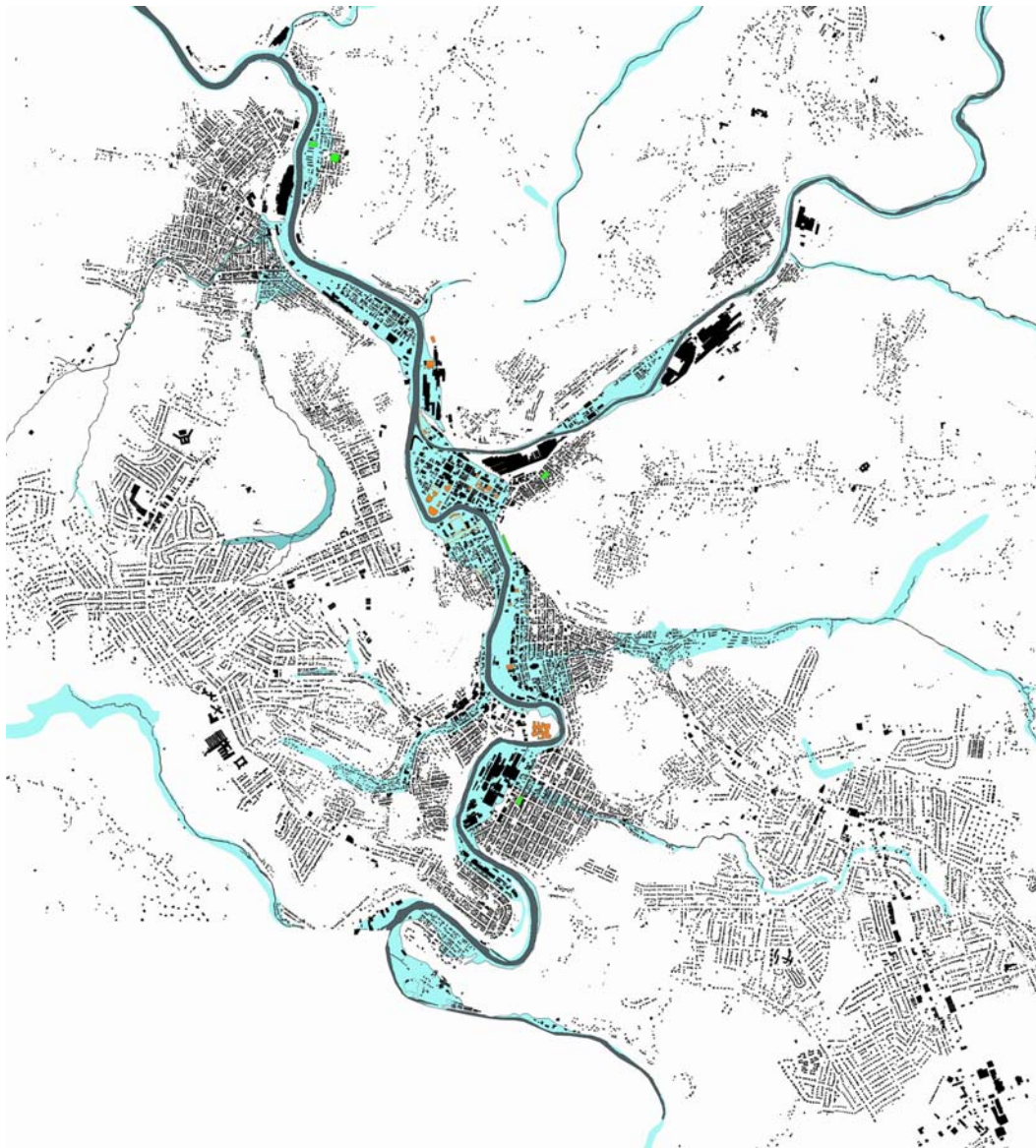

Figure 10: Map showing flood plane in Johnstown and River System. Image by author

The floods parallel if not overshadow the importance of the Steel industry in terms of the impact they have on the history of the town. On May 31st, 1889, there was a catastrophic flood in which over 2200 persons were killed. “Two subsequent floods, in 1936 and 1977, also caused loss of life... that served to reinforce the city’s notoriety as ‘that place where there was a flood¹¹’” (25). Stigmas associated with these small steel towns in the rust belt, whether caused by flood or economic failure, can have profound impacts on the ability of these places to remake themselves and create a new identity and self-image¹⁴.

Fourteen miles up the Stoney Creek River, water filled up the South Fork Dam basin during an unprecedented rainstorm. At 3:10 p.m. 20 million tons of water broke out of the Dam destroying nearly all of Johnstown. “The enormity and trauma of the disaster, the extent to which its account was published in newspapers and magazines, and the repetition of the story in other forms of popular culture ensured that Johnstown would never forget the flood¹⁵”(27). The flood became a major part of the city’s identity. Many of the surviving buildings and structures were imbued with meaning and special status as ‘flood survivors’.

Just as important as the buildings that survived the flood were many of the new pieces of construction. Many of the structures made during the rapid and extensive construction that took place after the flood were meant to represent the “Johnstown Spirit” of determination and vitality in the face of hardship¹³. The embodied meaning in each of these structures even to this day persists, sometimes

¹⁴ Connolly, James J. *After the Factory: Reinventing America's Industrial Small Cities*. Lanham: Lexington Books, 2012.

¹⁵ Wallace, Kim E. *The Character of a Steel Mill City: Four Historic Neighborhoods of Johnstown, Pennsylvania*. Washington, D.C.: Historic American Buildings Survey/Historic American Engineering Record, National Park Service, 1989.

even delaying their demolition even when new construction is promised as was the case with the Joseph Johns Junior High school. A Study carried out for the “Potential for Human Resources and Economic Growth” cites this example as halting the progress towards the future “adversely affected decision making and have further complicated problem solving in the twentieth century¹⁶” (28). Any new construction or building within Johnstown will have to address this ‘Johnstown Spirit’.

Flood Remediation Efforts

After the 1936 flood, the U.S. Army Corps of Engineers gouged, widened, deepened,



Figure 11: Picture showing the natural edge of the rivers in Johnstown.
http://www.toledoblade.com/image/2007/05/31/800x_b1_cCM_z/Revisiting-a-flood-116-years-before-levees-gave-way-in-New-Orleans-a-rushing-wall-of-water-obliterated-Johnstown-Pa-3.jpg

¹⁶ Wallace, Kim E. *The Character of a Steel Mill City: Four Historic Neighborhoods of Johnstown, Pennsylvania*. Washington, D.C.: Historic American Buildings Survey/Historic American Engineering Record, National Park Service, 1989.



Figure 12: After several devastating floods, the rivers in Johnstown were gouged widened and lined with concrete to make the city ‘flood free’. Image by author.

and realigned 9.2 miles of channel within Johnstown¹⁷. The Corps encased the river

banks within the town with concrete and steel in a campaign organized by the Chamber of Commerce. After being the only city in Pennsylvania not to flood after Hurricane Agnes in 1972 the town was proclaimed “flood free”. This designation would be short lived after the flood of 1977. The effect of these floods will be discussed further in following sections.

Paternalism

The difficulty in decision making and advancement is something that not only comes from the desire to preserve buildings with special meaning to the town, but perhaps more directly from the political clout that allowed the Cambria Iron Company to control the city council as well as “influence the business decisions of rivals in the community¹⁴” (19). This often was the case with ‘company towns’ where leadership

¹⁷ "Johnstown, Pennsylvania." Wikipedia. January 1, 2014. Accessed December 12, 2014. <http://www.wikipedia.org/>.

was provided by ‘the company’ and less by citizens. The Cambria Iron Company’s influence spread from its control of the sources of raw materials and transportation, but also the day to day aspects of its workers lives. Through its involvement in the various economic, cultural, and political bodies it had major control over public services directly and indirectly.

Various cultural and recreational institutions were supported by Cambria Iron. These included facilities such as a hospital, library, the Johnstown Opera House, YMCA, and the Art Institute for Women. Each of these facilities was set up by the company, and were maintained by membership fees and company contributions¹⁴ (22). All of these facilities and organizations no doubt were good for the town but did little towards developing citizen based civic leadership. Johnstown became almost entirely dependent on the Cambria Iron Company for support. The ability of the city to implement independent civic improvements was essentially ineffective, mostly due to the fact that Cambria was so dominant that the local governments had never had to develop these type of resources.

Also, because of the extensive influence Cambria Iron Company had on the town, almost all civic improvements and projects were facilitated when Cambria needed them. “When Cambria Iron decided it needed an expanded, reliable supply of heating and lighting gas, the town...received service as an appendage of the company¹⁸” (23).

This was also the case with services such as the telegraph lines in 1856.

¹⁸ Wallace, Kim E. *The Character of a Steel Mill City: Four Historic Neighborhoods of Johnstown, Pennsylvania*. Washington, D.C.: Historic American Buildings Survey/Historic American Engineering Record, National Park Service, 1989.

Chapter 3: Past Efforts from Johnstown

Johnstown Redevelopment Authority (JRA) - 1949

Overview

The first major organization that made efforts at recovering from the negative effects the Rust belt had on Johnstown was the Johnstown Redevelopment Authority established in 1949 following WWII. Johnstown along with other cities in Pennsylvania had prompted the state legislature to create the Urban Redevelopment Authorities Act of 1945. It's mission was to eliminate blight and dangerous conditions within the cities of Pennsylvania. The authority was formed by local governing bodies and operates independently from the national government after its establishment. The Johnstown Redevelopment Authority JRA provides a variety of programs that administer and manage the elimination of blighted areas for residential, recreational, industrial, and commercial opportunities¹⁹. It has completed a range of projects ranging from flood recovery efforts in 1977 through its most recent project in 2006 to recover methane gas produced from surrounding landfills. After the decline of the steel industry in Johnstown, the efforts of the JRA were focused primarily on the diversification of the Johnstown economy. "Clearing of urban and industrial land of both outdated structures and environmental liabilities, while encouraging small

¹⁹ "Johnstown Redevelopment Authority." Johnstown Redevelopment Authority. January 1, 2009. Accessed December 12, 2014. <http://www.johnstown-redevelopment.org/about.htm>.

scale resources to businesses²⁰. Importantly, this organization also engages citizens in a community vision for growth.

Timeline of Projects

Since its founding, the JRA has worked with the city of Johnstown as well as State and Federal Agencies to help the revitalization process. The various projects that have taken place range from flood recovery efforts after the 1977 flood to the ‘Johnstown Renaissance Project’ from 1998-2004 that introduced a new city conference center, The War Memorial Hockey Arena, and a Downtown Parking Center. Of the various projects undertaken, a few of the more notable will be discussed further.

Cambria city Renewal 1953-1967

The Johnstown City Planning Commission certified Cambria City, one of the original boroughs incorporated into the City of Johnstown, for renewal in 1953. A few months later the JRA submitted an application to the US Department of Housing and Urban Development. The first effort failed because the scope of the project was too limited and didn’t have enough long range programs directed at [urban decay] prevention²⁰. After a second attempt in 1960, many businesses in Cambria City developed including Pennsylvania Electric Company Headquarters, Thakray Supply Inc. and General Telephone Company. As a result 600 new jobs were created and taxes from the area to the city increased by \$20,000.²¹

Cambria Iron Works 1998-

²⁰ "Johnstown Redevelopment Authority." Johnstown Redevelopment Authority. January 1, 2009. Accessed December 12, 2014. <http://www.johnstown-redevelopment.org/about.htm>.



Figure 13: An aerial view of Cambria Iron lower works with various buildings labeled.
<http://www.epa.gov/reg3hwmd/bf-lr/newsletter/2007-Summer/cambria.html>

The Cambria Iron Lower Works is the oldest steel and iron industry site in Johnstown once producing 2 million tons of steel per year. In 1989 the National Park Service identified the Cambria Ironworks Complex as a National Historic Landmark²¹. Later in 1998 after some lengthy discussions, the JRA purchased three buildings within the Cambria Iron Lower Works including the Carpenter Shop, Machine Shop, Blacksmith Shop, and Electrical storage building. The JRA is currently undertaking an eclectic mix of redevelopment initiatives to transform the former Cambria Ironworks into a revitalized complex that merges 21st century businesses with historic structures.

Johnstown Renaissance Project 1988-2004



Figure 14: image of Frank J. Pasquerilla Conference Center. <http://www.johnstown-redevelopment.org/jtownrenaissance.htm>



Figure 15: Cambria County War Memorial Arena. <http://www.warmemorialarena.com/>

This project consists of the construction of three new buildings that are meant to serve as a “picturesque way of entering the City of Johnstown²²”. They are the Frank J.

²¹ "Johnstown Redevelopment Authority." Johnstown Redevelopment Authority. January 1, 2009. Accessed December 12, 2014. <http://www.johnstown-redevelopment.org/about.htm>.

Pasquerilla Conference center, Cambria County war Memorial Arena, and New Intermodal Transportation Center. Each of these three projects were conceived as signature pieces critical to the continued economic development of Johnstown.

Greater Johnstown Technology Park 2004-2008



Figure 16: Greater Johnstown Technology Park.
http://www.lrkimball.com/Federal_Architecture_Facility_Design_and_DB.aspx

In an effort to restore the vibrancy and economic vitality of Johnstown, the Greater Johnstown Regional Technology Complex Project was created on the site of an inner-city brownfield that now is the location of a medical technology and information technology complex. “Conemaugh Valley Memorial Hospital, Johnstown’s leading employer, has boldly moved forward to create a state-of-the-art complex²²”. This technology park complex now provides economic diversification, one of the main objectives of the JRA, accomplished through the promotion of technology-based businesses.

²² "Johnstown Redevelopment Authority." Johnstown Redevelopment Authority. January 1, 2009. Accessed December 12, 2014. <http://www.johnstown-redevelopment.org/about.htm>.

Johnstown Area Heritage Association - 1971

Overview

The Johnstown Area Heritage Association, founded in 1971²³ is an organization that is “dedicated to preserving and interpreting the nationally significant historic heritage of the Greater Johnstown Area through its museum facilities, historical collection, and educational programs²⁴”. Essentially it operates as a clearing house and a catalyst for Johnstown’s revitalization efforts. It is similar to the JRA but is focused on the cultural tourism and historic preservation of Johnstown.

Timeline of Projects

After the founding of JAHA (original called the Johnstown Flood Museum Association), its initial mission was to preserve and interpret the story of the 1889 flood²⁴. Today it has created many projects that were outlined in the Johnstown Heritage Development plan of 1991 and that are now located in what is called the Johnstown Discovery Network. Some of the projects and efforts of JAHA will be discussed further.

²³ "JAHA Mission." JAHA Mission. Accessed December 10, 2014. <http://www.jaha.org/AboutJaha/JAHAMission.html>.

²⁴ "Home." Home. Accessed December 13, 2014. <http://www.jaha.org/>.

Johnstown Flood Museum 1973



Figure 18: Johnstown Flood Museum.
<http://bachmantours.com/Home.htm>



Figure 17: Interior of Flood Museum.
<http://www.jaha.org/FloodMuseum/oklahoma.html>

The Johnston Area Heritage Association opened the Johnstown Flood Museum in 1989 marking the centennial anniversary of the flood²⁵. The Museum is located in the former Cambria Library that was built after the Flood of 1889 on the site of the old library. It now holds various photos and artifacts, news reports of the flood, and a multimedia map that explains the extent of the flood.

National Folk Festival 1990 / AmeriServ Flood City Music Festival



Figure 19: Flood City Music Festival Logo. <http://www.musicfestivaljunkies.com/festivals/flood-city-music-festival-2013/>

²⁵ "Home." Home. Accessed December 13, 2014. <http://www.jaha.org/>.

The AmeriServ Flood City Music Festival is a three-day celebration of American cultural heritage with various music performances. The festival got its start in Johnstown when city officials and JAHA recruited the National Folk Festival in 1990. This event brings both old and new musical artists to “celebrate the musical and cultural roots of America²⁶”. After this event was over Johnstown sought to create a similar event and titled it the Flood City music Festival.

Frank & Sylvia Pasquerilla Heritage Discovery Center 2001

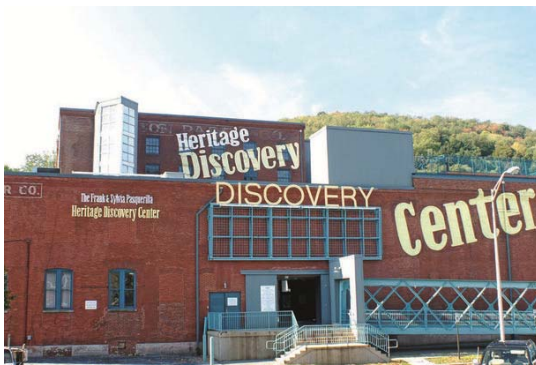

Figure 20: Exterior of Discovery Center.
Image by author.



Figure 21: Interior exhibit of Discovery Center.
<http://www.jaha.org/DiscoveryCenter/virtualtour.html>

The Johnstown Heritage Discovery Center is a part of the Johnstown Discovery Network. It serves as a community center that contains several attractions including, the Johnstown Children’s Museum, the Iron and Steel Gallery, and the “America: Trough Immigrant Eyes” exhibit. The Discovery Center is located in the old Germania Brewery Company building that operated until 1919 when at the advent of prohibition, the company sold off. After changing ownership over the next few years, in 1993 JAHA bought the building and transformed it into the Discovery Center.

Peoples Natural Gas Park – 2011-2012



Figure 22: Entrance of Peoples Natural Gas Park. Image by author.

The Peoples Natural Gas Park is the new home of the AmeriServ Flood City Music Festival. After JAHA purchased this site in 2004 they sought to develop this as the site for the festival. The park was master planned by L.R. Kimball Architecture, Engineering and Communications based on input from a study committee and public meetings in 2006. It was primarily financed with a 2 million dollar grant from the Commonwealth of Pennsylvania Redevelopment Assistance Capital Project. JRA procured matching EPA brownfield remediation funds.

Johnstown Heritage Development Plan - 1991

Overview

Shortly after the Johnstown National folk Festival in 1990 The Johnstown Heritage Development Plan was developed to take the ethos of the heritage festival and use it as a starting point to re-create the image of Johnstown as a destination for cultural and heritage tourism. There have been efforts in the past to revitalize Johnstown and to change its image. One of these effort was The Johnstown Heritage Development Plan.

This was an effort to revitalize the community and create a new image through the “use of cultural and heritage resources¹⁶” (1). This plan was pre-empted by the Johnstown Flood Centennial Celebration where hundreds of thousands of people visited the city to experience its history and culture. The successes of the celebration made the case for an economy based on cultural tourism, and a new vision of the city was born. In a report titled *Johnstown: The Third Century*, goals were outlined to expand the economic base of the city through cultural tourism while upgrading the built environment and quality of life for businesses and residents.

The plan was structured around two main objectives. The first, “To outline a program which can be locally implemented to help conserve Johnstown’s unique historical character²⁶” (1). By doing this, the proposed program would manage preservation efforts and design quality citywide in addition to providing financial initiatives for owners of historic property to upgrade them. The second objective was to “illustrate how the heritage and cultural tourism strategy could be developed¹⁶” (1) which would initiate development in two primary “pilot” areas where through joint public and private investment could create a network of cultural facilities, visitor services, and educational attractions as well as support for existing and new businesses.

The Johnstown heritage Development Plan was developed over a ten month period in June 1990 and was overseen by a “Steering Committee” that consisted of public agencies in Johnstown, City council, State and federal agencies, the banking and business community, local neighborhoods, and concerned citizens. This committee also met regularly to provide support, guidance and feedback to the technical work of

²⁶ Johnstown Area Heritage Association (Pa.). *Johnstown Heritage Development Plan*. [Johnstown, Pa.?]: Johnstown Area Heritage Association, 1991.

the project. One of these meetings was a community workshop called “Preservation: A Strategy for Community Revitalization²⁷” (2). At this workshop representatives of the business, development, industry, and neighborhoods spoke about the value of preserving the city’s heritage. The keynote speaker, Honorable John P. Murtha of the US House of Representatives, stressed the importance of Johnstown to the regional tourism industry and nation¹⁷.

Organization

The Development plan is organized into four sections. The first of which is entitled Developing Johnstown’s Heritage and states the purpose of the plan, an overview of the planning process, and key features of proposals. This section also asked the very important question, “Why Develop Johnstown’s Heritage?¹⁷” (3). The argument was made that the plan, in its essence, would be motivated by the strong conviction that investment in the historical and cultural fabric of Johnstown would benefit the economic vitality and quality of life in the city, its businesses, industries, and the private individuals and families who make it their home. Other main points include that the heritage is ‘the soul of the city’, it makes Johnstown unique from other places, it is a part of a regional development strategy, and perhaps most importantly it would encourage private investment.

²⁷ Johnstown Area Heritage Association (Pa.). *Johnstown Heritage Development Plan*. [Johnstown, Pa.?]: Johnstown Area Heritage Association, 1991.

Preservation Management Strategy

The next of the four main sections of the Heritage Development Plan was to implement a Preservation Management Strategy. The objectives were to outline a strategy to assist in the preservation of and investment in historic sites and settings within Johnstown. This goal aligns with one of the strategies mentioned in Connolly's *After the Factory*. She makes the argument that cities must first engage in a planning process to determine what assets they have and build upon them.²⁸

The Preservation Management Strategy outlined in the Heritage Plan consisted of a few key principles. The first is that the strategy should involve as many public groups as possible. It also mentions that it should do its best to work within the capabilities of existing public agencies instead of creating a new agency in order that any effort could get going as soon as possible. Next, this strategy would establish a new preservation agency only when and if a National Historic Park is established within the city that must also have sufficient resources to assist in the historic preservation of historic context. Lastly and very importantly the plan mentions that priority should be placed in Downtown and Minersville/Cambria City, it argues that these are districts most closely associated with the potential for a National Historic Park.

Short term and long term goals are outlined that explain the best methods for achieving the goals of preservation of historic structures. Short term goals include Nominating districts to the National Register of Historic Places; Identifying areas that

²⁸ 3. Connolly, James J. *After the Factory: Reinventing America's Industrial Small Cities*. Lanham: Lexington Books, 2012.

would best be suited for “Heritage Redevelopment”; and providing staff support as well as technical assistance through the Johnstown Area Heritage Association.

All of these efforts however would not happen simply through desire and good will. A key component would be to establish incentive programs through the Johnstown Heritage Development Trust. This would be a non-profit organization that would offer below market rate interest loans for improvements within the historic districts. Finally, long term goals would identify a National Historical Park which would consist of historically significant sites, establish local historic districts, and ultimately expand the capital base of the Johnstown Heritage Development Trust²⁹.

The Vision of a New Johnstown

In order for all of the preservation and redevelopment efforts to come to fruition, it is recognized that they all must cater to a new accepted vision of Johnstown. This vision could inspire people to believe that the city can ultimately be improved and can serve as the organizing force to guide all development under the proposed plan. The Johnstown Heritage Redevelopment Plan ultimately sought to create a new industry of cultural tourism within Johnstown with the aim of attracting visitors from the region to spend time and money. “By reclaiming traditional neighborhoods and buildings, supporting local ethnic and cultural organizations, and enhancing resources for the education of local school children³⁰” (23) this new vision of Johnstown as a historical tourist destination should serve to improve the image and quality of life within Johnstown.

²⁹ Johnstown Area Heritage Association (Pa.). *Johnstown Heritage Development Plan*. [Johnstown, Pa.?): Johnstown Area Heritage Association, 1991.

³⁰ Johnstown Area Heritage Association (Pa.). *Johnstown Heritage Development Plan*. [Johnstown, Pa.?): Johnstown Area Heritage Association, 1991.

Chapter 4: Emerging Solutions

Introduction

The problem of industrial ruins within Rust Belt cities is a multi-faceted one that must not only address the built scale, but also the planning and regional scale. It is unlikely that any one solution will be able to address all of the issues that these places face such as increase in crime, diminished tax base, decaying infrastructure, overburdened social services and more. Current research has shown that there must be efforts on multiple fronts. This chapter will discuss emerging solutions both theoretical and real: from small city revitalization theories to real examples that are case studies which demonstrate adaptive re-use.

Brownfield Remediation

Introduction

The term brownfield has changed in its connotations. We might now think of them generally as sites contaminated by some prior industrial use. This was not always the case. “The term Brownfield originated in the early 1990’s when practitioners and researchers saw the way emerging regulatory frameworks designed to protect the environment were, as a side effect, inhibiting reuse, cleanup, and redevelopment of

former industrial and commercial sites³¹” (1). Since then the term Brownfield has been appropriated and taken on new meaning. Instead of indicating a problem area that is to be avoided as was the case in the early 90’s, now brownfield sites are seen as places of opportunity. Although the Environmental Protection Agency still defines Brownfields as “idle property, the development of improvement of which is impaired by real or perceived contamination³²”. Now they are seen as developable sites with some remediation costs. Now more than ever is the opportune time to address these sites within the urban context.

Principles of brownfield Regeneration

In the text *Principles of Brownfield Regeneration*, many arguments are made in support of the advantages and opportunities in remediating and regenerating brownfield sites. “Brownfields, if reused can host new development and uses that would otherwise spread throughout undisturbed landscape outside of urban centers³³” (3). By cleaning up blighted and contaminated sites that may be located within the heart of a postindustrial city such as Johnstown, the city can be strengthened by allowing development in the city center as opposed to moving out of the city. It is also argued that, “reusing these sites brings many benefits to the quality of life in the surrounding neighborhood, such as reduced crime, enhanced local environmental

³¹ Hollander, Justin B., and Niall Kirkwood. *Principles of Brownfield Regeneration Cleanup, Design, and Reuse of Derelict Land*. Washington: Island Press, 2010.

³² "Basic Information." EPA. Accessed December 13, 2014.
http://www.epa.gov/brownfields/basic_info.htm.

³³ Hollander, Justin B., and Niall Kirkwood. *Principles of Brownfield Regeneration Cleanup, Design, and Reuse of Derelict Land*. Washington: Island Press, 2010.

quality, and improved property values” (3). All of these seem adequate justification to engage in the process of remediating brownfield sites because of the ripple effects of wide spread benefits that affect more than just the environmental health of the site, but extend to the region around the site.

How does the brownfield remediation process work?

One of the biggest barriers to remediating brownfield sites is not the contamination, but knowledge of how to properly implement remediation and reuse. The implementation processes need to include those who will be involved. The remediation team’s preliminary goal; communicate to adjacent property owners and to local or state officials; the relevant support programs and options for cleanup; insurance and financing³⁴. Johnstown has some of these support programs which have already completed various remediation efforts with the help of local and state bodies such as the JRA and JAHA.

The next three steps are also discussed in *Principles of Brownfield Remediation*, which are the creation of a community awareness or outreach programs that can help inform the larger community as well as gain the attention of knowledgeable people. Lastly, and perhaps most importantly, is the need to find support services and other resources. “The US EPA can be an important source of funding, technical assistance, and best practices in any brownfields project” (10).³⁵

³⁴ Hollander, Justin B., and Niall Kirkwood. *Principles of Brownfield Regeneration Cleanup, Design, and Reuse of Derelict Land*. Washington: Island Press, 2010.

³⁵ Hollander, Justin B., and Niall Kirkwood. *Principles of Brownfield Regeneration Cleanup, Design, and Reuse of Derelict Land*. Washington: Island Press, 2010.

Small City Revitalization

Turning Around Downtown: Twelve Steps to Revitalization

“The fact that many downtowns have experienced recent growth and development...is testament to the emotional commitment to our urban heritage and the pent up consumer demand for walkable, vibrant places in which to live and work³⁶” (1). This article examines steps that can be taken by smaller towns to revitalize themselves by promoting what it refers to as *walkable urbanism*. It goes on to argue that walkable urbanism, “is the key to the revival of any struggling downtown³⁷” (2). The steps outlined range from capturing the vision of the place to re-creating a strong office market. The key features of this strategy as related to Johnstown will be evaluated.

Downtown revitalization requires a degree of cooperation that is best achieved when a unique public-private process is used. “Every downtown has a unique set of strengths no matter how depressed it might be; it is these strengths that must be built upon in developing the revitalization strategy³⁸” (3). This strategy was also mentioned in the Johnston Heritage development plan. Johnstown sought to build upon its unique historical and cultural assets in order to create cultural facilities, educational attractions, and visitor services.

Just as important as creating a new vision of what a downtown could be is creating an advisory group that will create a detailed technical portrait of the

³⁶ Leinberger, Christopher B. *Turning around Downtown Twelve Steps to Revitalization*. Washington, D.C.: Brookings Institution Center on Urban and Metropolitan Policy, 2005.

³⁷ Leinberger, Christopher B. *Turning around Downtown Twelve Steps to Revitalization*. Washington, D.C.: Brookings Institution Center on Urban and Metropolitan Policy, 2005.

³⁸ Leinberger, Christopher B. *Turning around Downtown Twelve Steps to Revitalization*. Washington, D.C.: Brookings Institution Center on Urban and Metropolitan Policy, 2005.

downtown. This includes factors such as history, definition of size, the number of jobs and businesses and its role in the regional economy. After this step, the article calls for a subjective picture of the downtown mandating what is valued, what is missing, and the good with the bad. The Johnstown Heritage Development plan had already taken a similar approach to this by categorizing all of the historically significant areas in a Preservation Management plan. There were also group meetings in which local businesses, state officials, and active community members voiced opinions of what the downtown should be.

There are many skeptics who are opposed to downtown revitalization. Especially if there have been recent failures of previous attempts. “It takes a full generation to get over the collapse of a revitalization effort and the injection of fresh leadership³⁹” (4). This factor will play a pivotal role in the potential success or failure of any intervention in Johnstown given the many efforts by the JRA and JAHA. However, the benefits of downtown revitalization are too numerous to ignore. The author mentions that by definition, a downtown recovery means that there will be more residents and more jobs which leads to out-of-town visitors bringing more money into the area. Other benefits include the likely retention of the ‘creative class’ of workers. However, if there is not good urbanism and, “these workers do not have walkable urbanism and its advantages, why should they come or stay?²⁹” (4).

Before any downtown can get to this point, there must first be a ‘critical mass’ of pedestrian-scale uses such as boutiques, hotels, grocery stores, housing, and offices. In order to set the stage for this type of development, Leinberger argues that

³⁹ Leinberger, Christopher B. *Turning around Downtown Twelve Steps to Revitalization*. Washington, D.C.: Brookings Institution Center on Urban and Metropolitan Policy, 2005.

early progress of downtown revitalization must provide for the building of infrastructure which is to include walkable streets, intra and inter-core transit, shared use structured parking, culture and entertainment, as well as increased safety and cleanliness. Only after these things have been implemented or their foundations laid, will the private sector developers and investors be attracted to the Downtown. Most of this infrastructure is already in place in Johnstown such as the Intermodal Transportation center that was part of the Johnstown Renaissance Project in 1998.

Although Johnstown seems to have set the stage for revitalization, the author also makes the clear point that “only by re-establishing a private sector real estate market can a downtown prosper⁴⁰” (4). In order for this to happen the housing stock of Johnstown needs to be considered and is discussed later in the *section Improved Housing Stock*.

Welcome Back Downtown: A Guide to Revitalizing Pennsylvania’s Small Downtowns

In a similar article to that of Christopher Leinberger, *Welcome Back Downtown* outlines the why and what of revitalization including revitalization techniques and case studies. It defines Downtown revitalization as “strengthening the social, physical and economic value of a community’s commercial center...where businesses have traditionally located⁴¹” (3). It also goes on to discuss that downtown revitalization is not only retail development, but is community development that improves the quality

⁴⁰Leinberger, Christopher B. *Turning around Downtown Twelve Steps to Revitalization*. Washington, D.C.: Brookings Institution Center on Urban and Metropolitan Policy, 2005.

⁴¹ Shields, Martin, and Tracey L. Farrigan. *Welcome Back Downtown: A Guide to Revitalizing Pennsylvania's Small Downtowns*. Harrisburg, Pa.: Center for Rural Pennsylvania, 2002.

of life. The benefits of revitalization include but are not limited to increased employment, prevention of blight and abandonment, increased safety, expanded tax base, and more retail options.

Of the many techniques discussed for revitalization the first is generally improving appearances. This can be done through the development of public space maintenance programs, planting trees, using vacant storefronts to display local retailer goods, and raising crosswalks to increase pedestrian safety. Other strategies include improvement of parking and traffic flow. This was done in Johnstown as part of a revitalization effort in 1988 that included the building of a hockey arena and conference center.

Other strategies outlined are improving local business practices, historic preservation, and tapping into tourism. Almost all of these strategies have been outlined in the Johnstown Heritage Development Plan. Interestingly housing stock is not mentioned.

**Rightsizing cities – The City after Abandonment / Shrinkage vs Renewal –
Design After Decline**

Even though there are many sources that discuss revitalization strategies as it relates to the downtown or to the entire city, a chapter of *Design after Decline* questions whether or not revitalization is the proper response or if shrinkage is. This phenomenon of ‘shrinkage’ was caused by the demolition of empty and abandoned houses following the post 50’s population decline of the city. Later in the 1970’s, the United States abandoned the enterprise of state-driven urban redevelopment in favor

of decentralization and private initiative⁴². The result of this is planning in the US as well as Europe has now been following the lead of private sector developers in the rebuilding of cities. Brent D. Ryan argues that this strategy is ideal in that obeying the market's wishes is the best path for building cities. Conversely this strategy has also, "cast shrinking cities adrift, leading them to spend hundreds of millions of dollars on downtown megaprojects³⁴" (288). Small cities are subsidizing developers to construct housing even though they are ignoring the challenge of improving conditions in the isolated, abandoned areas that grow larger as this decline continues.

One of the most important arguments that Ryan makes is an approach to the current state of shrinkage happening within these cities. What it calls for is a, "benevolent, interventionist, critical urban design approach, can begin to undo the neglect of the laissez-faire planning of the past half century and begin to project a future for shrinking cities that goes beyond the piecemeal abandonment and demolition they currently experience³⁴" (288). The challenges that these shrinking cities face are scarce political funds, and inadequate power to implement significant urban design change. Johnstown will have to use all the resources they have such as the JRA and JAHA to make a significant impact on planning. Despite these, "robust urban design has the ability to transcend these [difficulties]"³⁴ (288).

The last call to action that is mentioned to combat the challenges of shrinking cities is the construction of, "concentrated and innovative new neighborhoods [that] will change urban development as usual and place new demands on non-profit and

⁴² Ryan, Brent D. *Design after Decline: How America Rebuilds Shrinking Cities*. Philadelphia: University of Pennsylvania Press, 2012.

public agencies accustomed to decentralization action⁴³” (288). What will these new neighborhoods look like? The result will most likely vary by location because of differing degrees of abandonment, the condition of infrastructure, and the amount of historic structures. Instead of having a unified one size fits all solution, the city will become a mosaic of old, new, vanished and vanishing neighborhoods intermingled within the bounds of the historic city³⁵. Rightsizing cities as a solution or strategy for addressing the problems that rust-belt cities face will be a challenging endeavor. “Rightsizing shrinking cities represents a new opportunity for urban design and planning to take the lead in shaping the future of distinctive urban environments³⁵” (288).

⁴³ Ryan, Brent D. *Design after Decline: How America Rebuilds Shrinking Cities*. Philadelphia: University of Pennsylvania Press, 2012.

Adaptive Reuse

“What we need is continuity...historic preservation is not sentimentality but a psychological necessity. We must learn to cherish history and to preserve worthy old buildings...we must learn how to preserve them, not a pathetic museum pieces, but by giving them new uses⁴⁴”

Theories and Philosophies

The process of adaptive reuse is a method of building that is critical of the simple preservation of historic structures. While in some instances the museum approach to preservation is appropriate, it will not work as a general approach⁴⁵. In the text *Adaptive Reuse* from Professor David G. Woodcock, he makes the argument that change is an inevitable part of life and it should be celebrated rather than regretted³⁷. He also acknowledges that the change of urban renewal that happened in the 60's, similar to some points made in *Rightsizing Cities*, had led to environments that could be described as urban wastelands. Adaptive reuse of historic structures, instead of tearing them down or simply appropriating them into a museum, can help to prevent the creation of these urban wastelands.

Implementation

In order to begin an Adaptive reuse project there are two primary factors to consider. The first are the various advantages and challenges associated with this

⁴⁴ Huxtable, Ada Louise. "Lessons in Healing the Cities Scars." *The New York Times*, May 27, 1973.

⁴⁵ Austin, Richard L. *Adaptive Reuse: Issues and Case Studies in Building Preservation*. New York: Van Nostrand Reinhold, 1988.

undertaking. An advantage of adaptive reuse is that these project are often labor intensive. This creates jobs which often requires the learning of new techniques, “and in neighborhood projects the concept of ‘sweat-equity’ has also carried with it genuine retraining programs that help participants develop permanently useful skills⁴⁶” (ix). Some of the challenges these projects can face are the aesthetic relationship between the old and new construction as well as contemporary design challenges in terms of heating, and cooling, lighting, life-safety, accessibility, and new functional demands that are difficult to integrate into the old framework³⁸.

The second is economic incentives for this action. The first point that is brought up by the author is that older buildings are generally more energy efficient than present day buildings. Although this may vary widely based on a case by case analysis, especially given consideration to the type of structure being examined, there is one aspect that cannot be overlooked: the embodied energy in the construction. This is a resource that is non-renewable and should be taken advantage of.

Precedents

Various Precedents of adaptive re-use projects will be discussed in detail in Chapter 5: integration of Steel Mill into City Fabric.

⁴⁶ Austin, Richard L. *Adaptive Reuse: Issues and Case Studies in Building Preservation*. New York: Van Nostrand Reinhold, 1988.

Improving Housing Stock

Introduction

A major problem that Rust Belt cities face is staggering population decline.

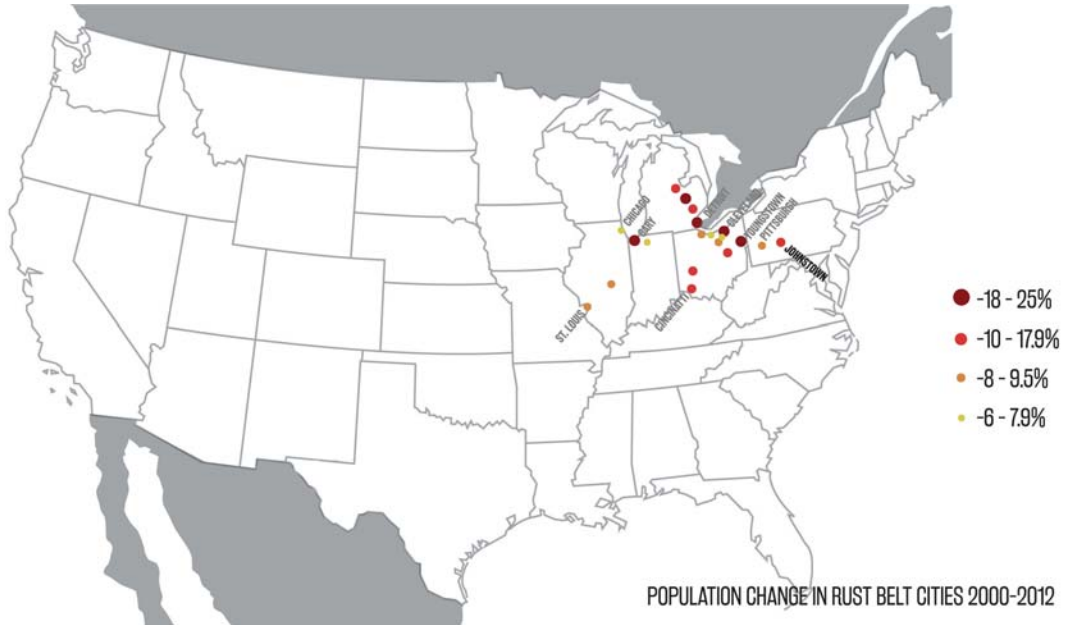

Figure 23: Population Change in Rust Belt Cities 2000-2012. Image by author.

Fig. 22 shows the percentage of population decline in rust belt cities such as Cleveland, Youngstown, and Detroit which lost between 18-25% of their populations between 2000-2012. Johnstown isn't far off this mark losing between 10-18% of its population in the same period. This significant decline can most usually be linked to the decline in manufacturing jobs. However, another cause that may be unknowingly linked to this is the housing stock or the types of houses available in Rust Belt Cities. The current housing stock consists of mostly dilapidated structures that are

abandoned or have been neglected for some time.



Figure 24: Typical Abandoned housing seen in Downtown Johnstown. Image by author. Many people lack the knowledge and investment capital to restore these homes. Even if they are restored the living spaces within them (kitchen size, bathroom size and number) are no longer desirable. They also have outdated electrical systems, plumbing and heating / cooling systems.

Confronting Urban Population Decline



Figure 26: Aerial image of Downtown Johnstown in the 1950's
(<http://www.jaha.org/edu/flood/rebuild/img/panoramas/index.html#1920a>)



Figure 25: Aerial image of downtown Johnstown 2014. Google Earth.

In the Article *Confronting Urban Population Decline*, Jason Segedy discusses how cities are not only losing their populous at an alarming rate, but they are also loosing much of their housing stock meaning that they are losing most of their built environment. “As the 21st Century dawned, many older cities began shrinking, not primarily as a result of national demographic trends (household size) or lifestyle preferences (suburban development), but simply due to the fact that many of them were losing their supply of marketable housing⁴⁷”. In order to remedy this, Segedy calls for new housing within the old city because cities, such as Johnstown, “have an over-supply of housing that people do not want, and an under-supply of housing that people so want⁴⁸”.

⁴⁷ Segedy, Jason. "What's in a Number? Confronting Urban Population Decline." What's in a Number? Confronting Urban Population... November 5, 2014. Accessed December 13, 2014. <http://thestyle1972.tumblr.com/post/101874810155/whats-in-a-number-confronting-urban-population>.

⁴⁸ Segedy, Jason. "What's in a Number? Confronting Urban Population Decline." What's in a Number? Confronting Urban Population... November 5, 2014. Accessed December 13, 2014.

Along with this, there have been recent emerging social trends, outside the scope of the Rust Belt and post-industrial cities that have had an unforeseen effect on population loss. Trends between 1960 and 1990 include changes in marriage such as increased divorce and delayed marriage which results in more singles. Changes in health care include increased longevity, and also changes in general reproduction with the advent of “The Pill” in 1960 which has resulted in fewer children. Seemingly unconnected as these may seem, Segedy argues that the end result of these trends overall is a much smaller average household size. He later concludes that if older cities [are] unable to build more housing units...they were going to shrink to a significant degree, regardless of the crime rate, school quality, of any of the other common explanation for urban population loss⁴⁹.

Overall, population loss is one of the biggest challenges that these cities face. With population loss comes abandoned buildings, loss of city fabric, diminished tax base to maintain existing infrastructure, as well as the stigma of abandonment as a result of the current aging housing stock. Segedy confirms this stating that, “there is a correlation between the amount of older housing that a city had and the degree of population loss that it has experienced⁵⁰”. In order to combat this symptom that many Rust Belt cities face, I believe that these places, as well as the city of Johnstown need improved housing stock to cater to new demographics and ultimately improve the quality of life within the city. Given Johnstown’s manufacturing history, it only

⁴⁹ <http://thestyle1972.tumblr.com/post/101874810155/whats-in-a-number-confronting-urban-population>.

⁵⁰ <http://thestyle1972.tumblr.com/post/101874810155/whats-in-a-number-confronting-urban-population>.

seems natural that this intervention should also re-use the many post industrial buildings the city has.

Chapter 5: Demonstration (Thesis Project)

My Strategy

Johnstown is a city that has undergone various attempts at revitalization and been subject to various urban renewal efforts, rebranding strategies and civic engineering projects, some with more success than others. The resiliency of the city is remarkable given the vast array of hardships the town has had to face from economic troubles to natural disasters. Because Johnstown has had such a variety of approaches implemented, one wonders whether or not a new strategy to bring about a renaissance will be any different or more effective than past efforts?

I believe that there is not one overarching solution to the problems that Johnstown and other Rust Belt cities face. If these places are to reach a new renaissance there must be intervention at different scales branching across many different disciplines in order to give the city new life, new purpose, more economic vitality. Instead of aiming towards one verifiable solution to all of the problems Johnstown faces, this thesis seeks to present creative overlays at various scales in order to show the potentiality of Rust Belt cities to transform themselves into thriving urban centers. Just as when Johnstown rebuilt after its tragic floods, just as Johnstown was resilient in the face of changing technologies from the canal systems to rail, and just as Johnstown has taken efforts to re-brand itself and cater to cultural tourism, it is now the time for Johnstown to be resilient again and transform itself into a showcase of the application of sustainable urban principles, new adaptive reuse strategies and innovative water management strategies. Only after the city takes these various steps

and sets a strong urban foundation will Johnstown be ready for its next renaissance and new life.

City Scale strategies

Urban planning to reinforce original parti of downtown

The first major step the city must take is a comprehensive urban planning strategy to

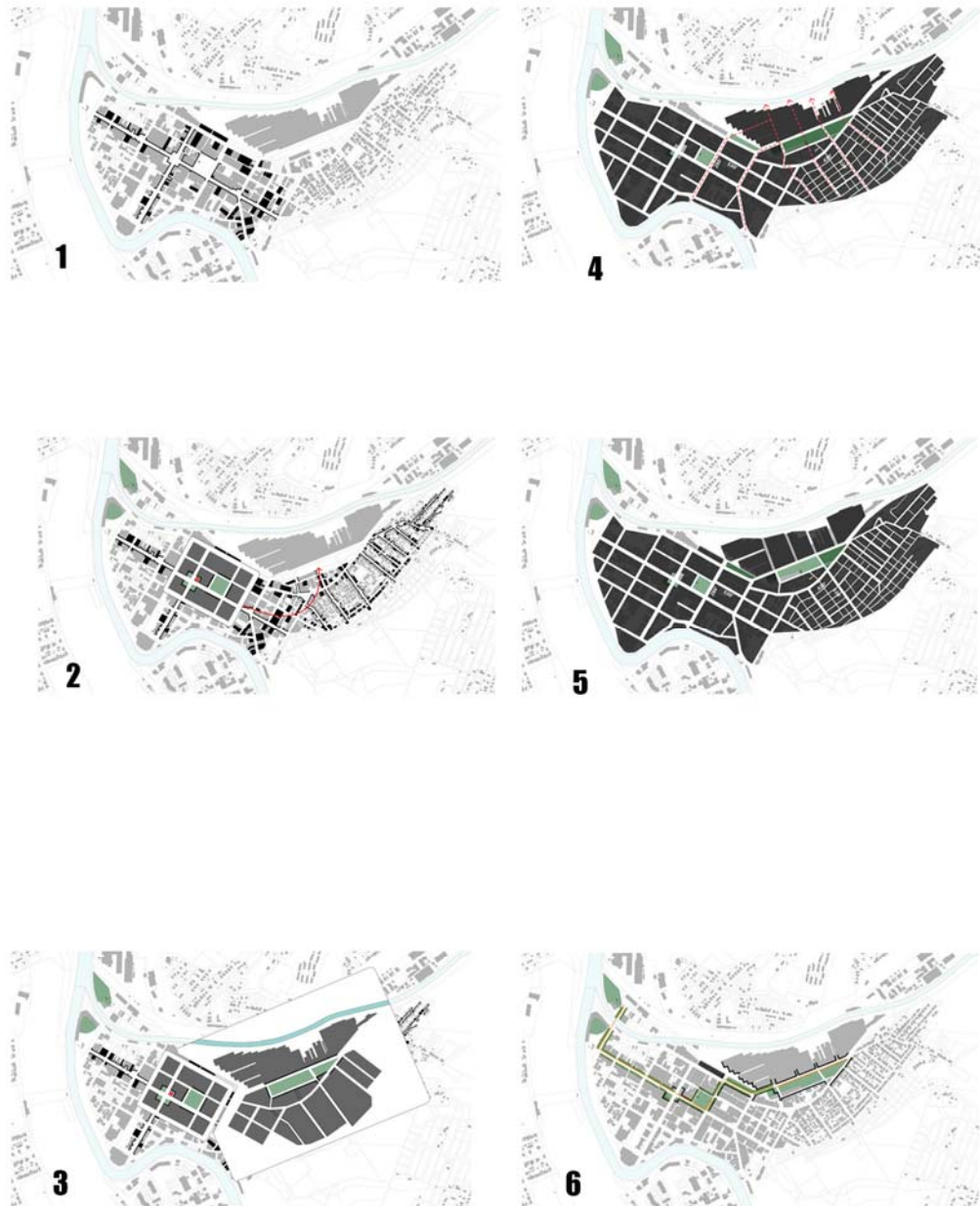

Figure 27: diagrams illustrating methodology to improve urban quality of Downtown.

reinforce the original parti of the downtown, to promote walkable urbanism, and to lay the foundations for future growth and change. Figure 26 shows in its first step that in order to reinforce and strengthen the original parti of the downtown, various buildings are proposed as black figures. The main cross streets are outlined with a black edge to show their hierarchy. Step two and three in Fig. 26 shows how the generalized parti from downtown can be overlaid on the city fabric next to the steel mill to organize this area around a central green space. Steps 5 and 6 illustrate how the existing street network can be used to divide the footprint of the steel mill and to break it down into block sizes comparable to the existing city fabric. Then step 6 shows the new connected central green spaces of downtown and the steel mill.

Integration of steel mill into city fabric

In conjunction with city planning efforts, the existing infrastructure must be taken into account, especially that of the Gautier Steel Mill. This structure has a footprint almost half that of downtown. Its physical presence speaks to the influence that the steel manufacturing industry had on Johnstown as well as other Rust Belt Cities. Often the question is asked, ‘what is the future of these places?’

Precedents from other cities similar to Johnstown reveal a variety of approaches from the complete removal of these large pieces of infrastructure as is the case at the Almono Steel Mill in Pittsburgh (Fig. 28) and the North Macadam Industrial Area in Portland Oregon.



Figure 28: Aerial of the Almono Steel mill site.
<http://www.popcitymedia.com/features/development102214.aspx>

These precedents illustrate almost complete removal of old industrial infrastructure followed by large planning efforts, essentially a clean slate strategy. A major drawback to this approach is not only the loss of infrastructure, but the loss of history and identity of the place.

Contrary to these two examples are instances where these infrastructural remnants or industrial ‘ruins’ are preserved. This is the case with the Landschaftspark (Fig. 29)



Figure 29: Image of landschaftspark.

<http://www.popcitymedia.com/features/development102214.aspx>

Duisburg Nord in Germany. Duisburg is an abandoned industrial factory that was preserved in its entirety with a natural park introduced within the confines of the project with the intention that the resulting project would work to heal and understand the industrial past rather than trying to reject it ⁵¹. A similar approach at a smaller scale can be seen in the Foundaries Garden in Nantes France. In this instance there is an effort to preserve the existing structure with more freedom in manipulation of the

⁵¹ http://en.wikipedia.org/wiki/Landschaftspark_Duisburg-Nord

form. Both of these examples show how the introduction of a new program can serve to preserve and understand the past as well as overlay new use.

The most integrative repurposing and reuse of industrial ruins can be seen in the Urban Outfitters Headquarters in the Philadelphia Naval Yard by MSR Architects and the Plant at Kyle Texas by Lake Flato Architects (Fig. 30).



PHOTO © RENO FIZZI

Figure 30: Image of the Plant at Kyle. <http://www.theplantatkyle.com/full/index.html>
Each of these have introduced new program into the existing infrastructure resulting in the richest physical palimpsest of uses and a layering of history and architectural experience. I believe it is this last approach illustrated in the Lake Flato Project, that will be the most appropriate for Johnstown. This strategy represents the most comprehensive repurposing of an industrial ruin down to a detailed level, one that the Gautier steel mill should take as a precedent.

Neighborhood Scale

The way in which the steel mill can be most successfully integrated into the city fabric is to incorporate influences from the surrounding neighborhood. Through a



Figure 31: Schematic designs of the Gautier steel mill continued. Image by author.

Given Gautier’s location next to a section of the Stony Creek River provides the opportunity to question and re envision the current edge condition to the river as well as the storm water management ideologies that led to its current concrete formed edge to maximize the water flow.

Both of these two points were examined extensively in plan studies that suggest new formal arrangements of the Gautier steel building as well as varied approaches to the current edge condition in an attempt to re-establish a riparian buffer that was eradicated as a result of the concrete lining of the stream seen in Figures 31

and 32. Each one of these iterations is meant to show different potentialities of how the steel mill can be better integrated into the urban fabric. Also, each scheme could be a beginning point for future development. Their goal is to establish a set of guidelines and show the variance of the guidelines so that if development is undertaken, any one of the schemes could be a valid response.

New storm water management strategy

The next design challenge is to propose new water management strategies which can also serve as an informative underlay to the new urban design and character at the neighborhood scale. Johnstown's history of flooding and failed remediation efforts of the past serve as justification for dramatic rethinking of its storm water management infrastructure. Instead of increasing the speed at which water flows out of the city, as was the idea with the channelization of the rivers within the downtown, it is now seen as best practice to absorb as much storm water as possible on site and to limit the amount of water going into the river in the first place. This approach effectively seeks to turn the site into a sponge that can absorb water gradually back into the water table instead of simply trying to move it away from the city as fast as possible.

Figure 32: Section of proposed green street detail. Image by author.

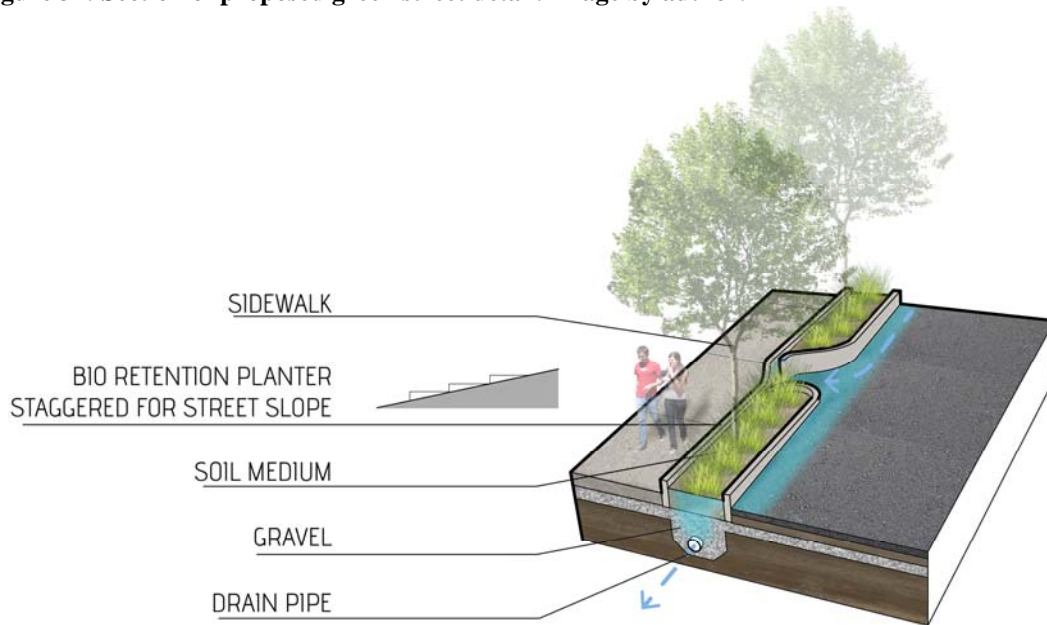

The first area that will be examined are the streets that slope down to the Gautier steel mill (Fig. 34). In order to reduce the amount of water runoff that flows down these streets, a series of water retention beds will be integrated into the existing streets (Fig. 33). These will aid in the retention of water with the additional benefit of improving the walkable nature of these streets.

The next area for storm water management is located in the central green space of the newly proposed urban plan. This new park has a large water retention pond that has a chevron pattern that is derived from a Sanborn map overlay. Originally the crescent block in which the park is located was the footprint of the old canal basin that ran through downtown Johnstown. In order to create a park that is not only a pleasant place to stay but also functions as a large piece of storm water

management infrastructure, the original footprint of the canal basin will be interpreted and



Figure 33: location for design of green streets. Image by author.



Figure 34: Aerial image of new park space. Image by author.



Figure 35: Storm water park flooded to reveal the shape of the canal basin. Image by author.

incorporated into the north side of the park space (Fig. 35). When there is a large rain storm and the storm water park begins to fill up, the original canal footprint will reveal itself as seen in Figure 36.

The last place that will be re-envisioned is the edge condition between the Gautier Steel Mill and the Stony Creek River. As it is currently situated there is a hard edge between the Gautier Steel mill and the river manifested in the sloping concrete channel edge. In a methodology converse to that which justifies the channeling of the river, various schemes were examined to break up the river edge and restore a natural riparian buffer edge in an effort to turn this large piece of storm water infrastructure into an amenity space, slow down the flow of water, and introduce plant life that can filter and clean contaminates in the water. Within the footprint of the Steel mill, certain pieces or ‘bar bills’ will be removed and allow for an expanded water edge and natural riparian buffer zone as seen in Figure (37).

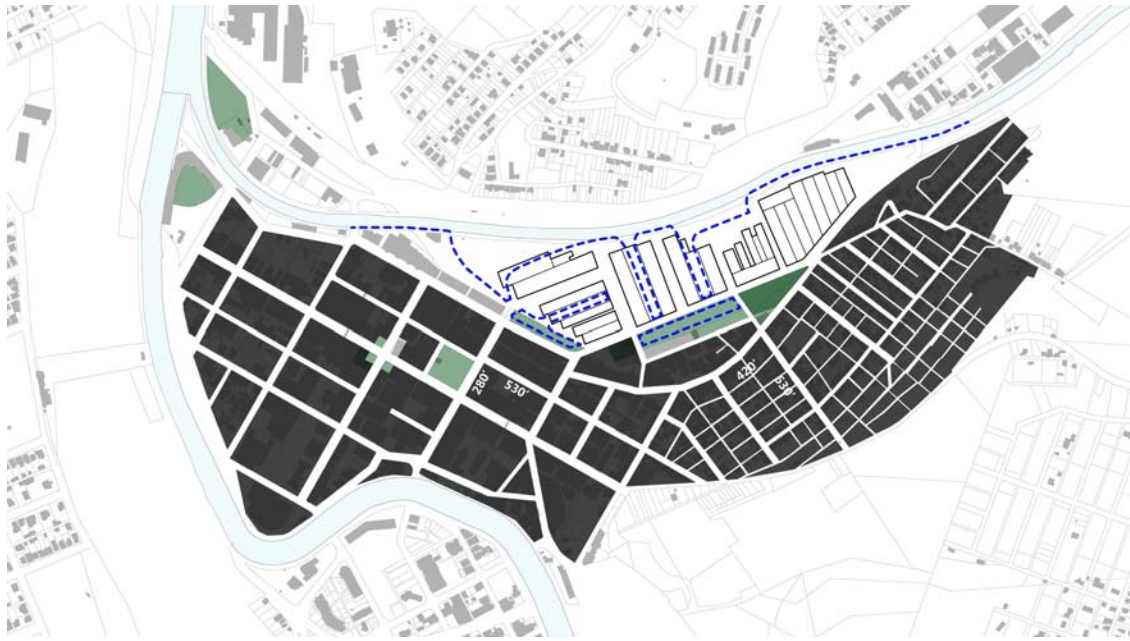

Figure 36: New edge of river adjacent to site. Image by author.

The nature of the space where this new edge condition exists provides a new piece of storm water infrastructure that has a cascading terrace in two foot increments that allows for the slow drainage and filtration of storm water runoff into the river system. It also allows for the reception of rising water in a way that can be quantified by the two foot increments of the step height changes. The character of this space is illustrated in Figure (38).



Figure 37: Section perspective illustrating experiential nature of new storm water management riparian edge. Image by author.

Building Scale

At the building scale, there is the opportunity to examine the potential for new program being inserted into the industrial fabric. After researching different methods and programs that these structures could sponsor, the focus was narrowed to new housing. The argument for this is that providing updated housing stock may be one of the most effective solutions to the diminishing population of Rust Belt Cities. Jason Sedegy makes the argument that the reason people don't want to move back into Rust Belt cities is that "many of them [have lost] their supply of marketable housing⁵²". As is the case of many rust belt cities, in Johnstown there is an overabundance of outdated housing types that have fallen into disrepair. Even if these houses are renovated the living spaces are likely to be outdated and undesirable. By introducing housing into the Gautier Steel Plant structures, they could potentially draw new demographics which would help to increase population by providing great places to live within the improved urban environment that has been addressed earlier.

The strategy of introducing housing into these structures is not only an architectural problem, but one that has to address cultural and historical meaning inherent within the Gautier Steel Mill. This is especially true within the Gautier steel mill because of the embodied social and economic history of these structures. The very urban setting in which this steel mill sits can serve as a precedent and justify the insertion of housing as a program. To explain, back when the mill was operational, most of the workers lived in the homes that were only a 5 minute walk up the hill

⁵² Sedegy, Jason. "What's in a Number? Confronting Urban Population Decline." What's in a Number? Confronting Urban Population... November 5, 2014. Accessed December 13, 2014. <http://thestyle1972.tumblr.com/post/101874810155/whats-in-a-number-confronting-urban-population>.

from the mill (Fig. 39).



Figure 38: Map showing old uses of different city blocks. Image by author.

This idea of living near where you work can be utilized and reinterpreted within the steel mill itself. Now, instead of the mill only being a place for work, the ground floor can cater to new service based jobs and start-up companies. Then, just as people would walk up the hill to their homes, now people simply walk upstairs in newly created live/work units. Figure 40 illustrates how this typology of live work units can be integrated into the existing steel mill footprint in a way that responds to existing uses and programs.

Figure 39: New proposed building uses for new Gautier steel mill buildings. Image by author.

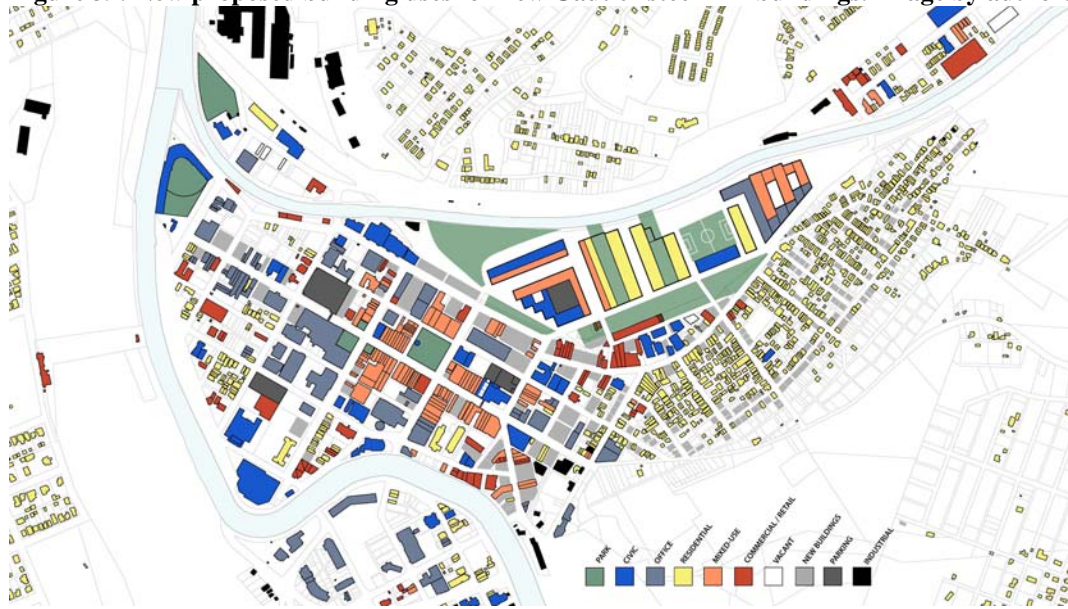

In order to determine the most appropriate method of inserting the typology of housing within the existing structure, various precedents were examined in order to extrapolate design intent and tectonic logic that could be applied to the Gautier structure. Some of these studies can be seen in Fig (41)

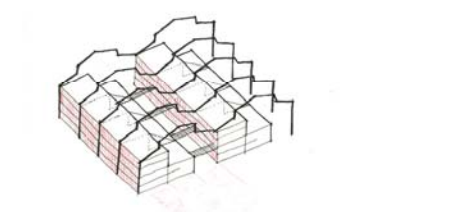
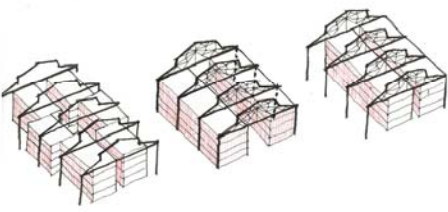
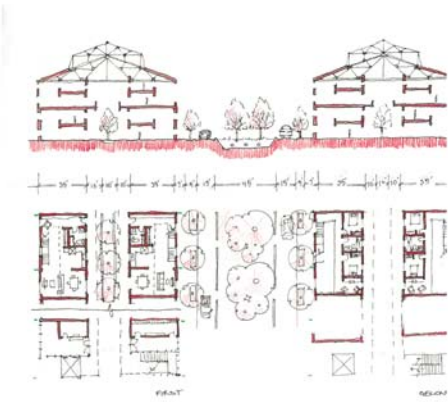
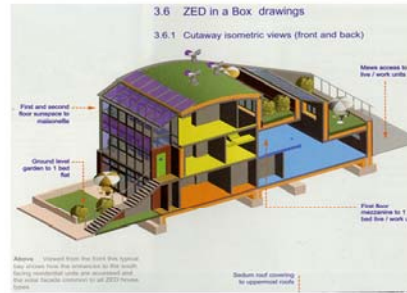

Figure 40: Drawings illustrating precedent insertions into existing Gautier steel mill structure. Image by author.

where the parti's of various precedents have been 'inserted' into the existing column grid to understand the best method for introducing the housing program. Two precedents are illustrated in Fig.41. One is the Torpedo housing by Vandkunsten architects in Copenhagen as seen on the left. This example was chosen because it has similar dimensional portions to the Gautier steel mill. The next precedent was the Bedford Zero Energy Development Housing in England, or BedZED, that can be seen on the right of Fig.41. This precedent was shown because it not only introduces the program of housing into structures with similar character to the Gautier steel mill, but also incorporates spaces for offices which provides a nice mix of live and work space (which is argued for in the previous section). Either of these two precedents could be adapted and implemented into the Gautier steel mill. These drawings are meant to show the range of possibilities when inserting new program into the Gautier Steel mill instead of trying to come up with a verifiable solution.

This introduction of new program into the existing structures also brings to light exciting opportunities in the tectonic expression of the new program within the existing structure. Original construction details, rhythms and materials can be redeployed in a way that doesn't try to 'fake' the original appearance but can still be informed by it for a more unified composition. The unique edge conditions that are a part of the site design can also merit completely new architectural and tectonic responses that add to the composition of the whole as presenting the new reading and the interpretation of the old. These will be discussed further in the *Detail Scale* section.

Detail Scale

The design exercise of introducing new programs into these old industrial structures is a challenging and exciting one. Influence for the cladding can be taken from the brick exterior, or a new tectonic language can be developed from the new edge condition that these structures will create. Also, as a result of the deletion of portions of the existing structure, lengths of the building massing that have never supported a façade or cladding will have to be addressed. In order to develop a façade system for the housing component, tectonic details to express the structural pieces were compiled into a matrix (Fig 42).

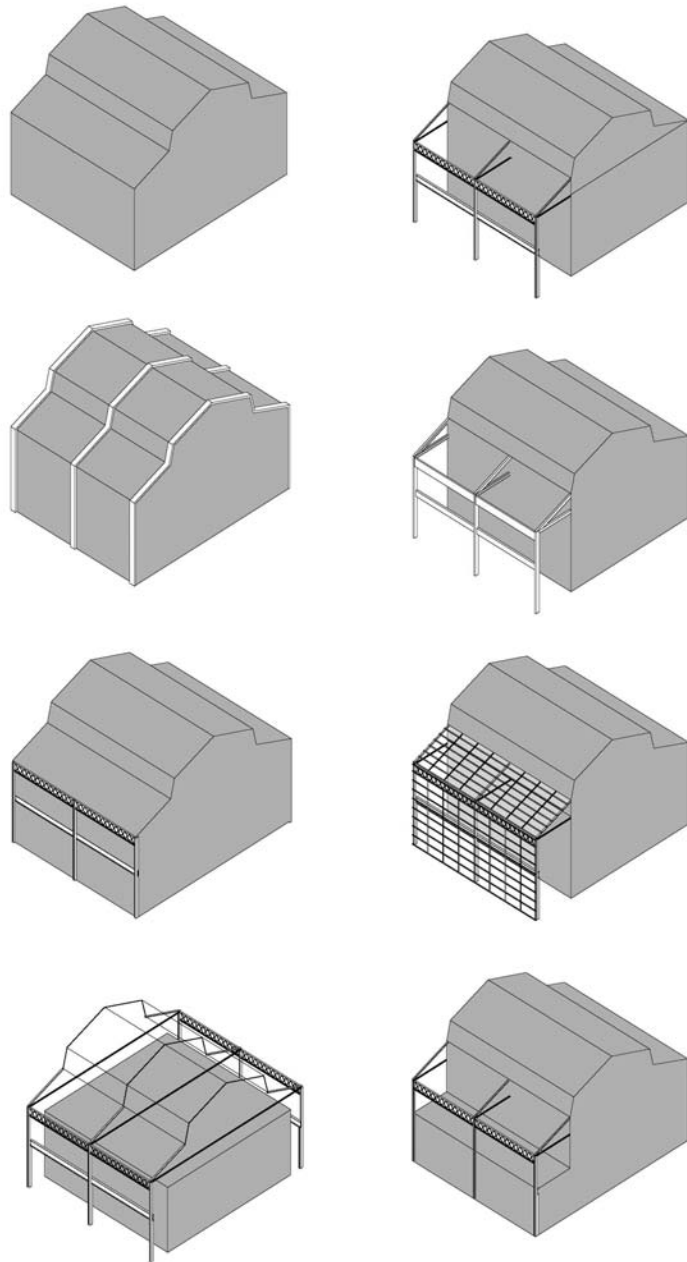

Figure 41: Matrix showing variance of structural expression. Image by author.

Each is a viable option and the creation of this matrix is meant to serve as a stepping off point so that no matter what program is introduced into the Gautier steel mill, an appropriate expression of structure can be achieved.

As Demonstrations, the façade that was chosen has two different material expressions. Just as brick was originally used on the exterior of the mill, it is redeployed as the cladding system on the outer most edges of the housing block seen in Fig 43. Grid lines from the metal framework of the original brick façade are carried over to the new brick façade to create continuity between the two. Also, in the same way that there is a ‘half timbering’ exercise of infilling this steel grid with brick that informs the location of the windows, this is carried over to the new brick façade seen in Fig 44. On the interior section of the housing block (Fig. 45) a glazing system is deployed. Because these facades shown in Figure 45 are located next to the proposed riparian edge, this provides the opportunity for a new tectonic expression that can be liberated from the original brick. However, in order to preserve continuity between the old façade and new façade, the steel grid lines are preserved on the glazed facades just as in the new brick facades seen in Fig.46.

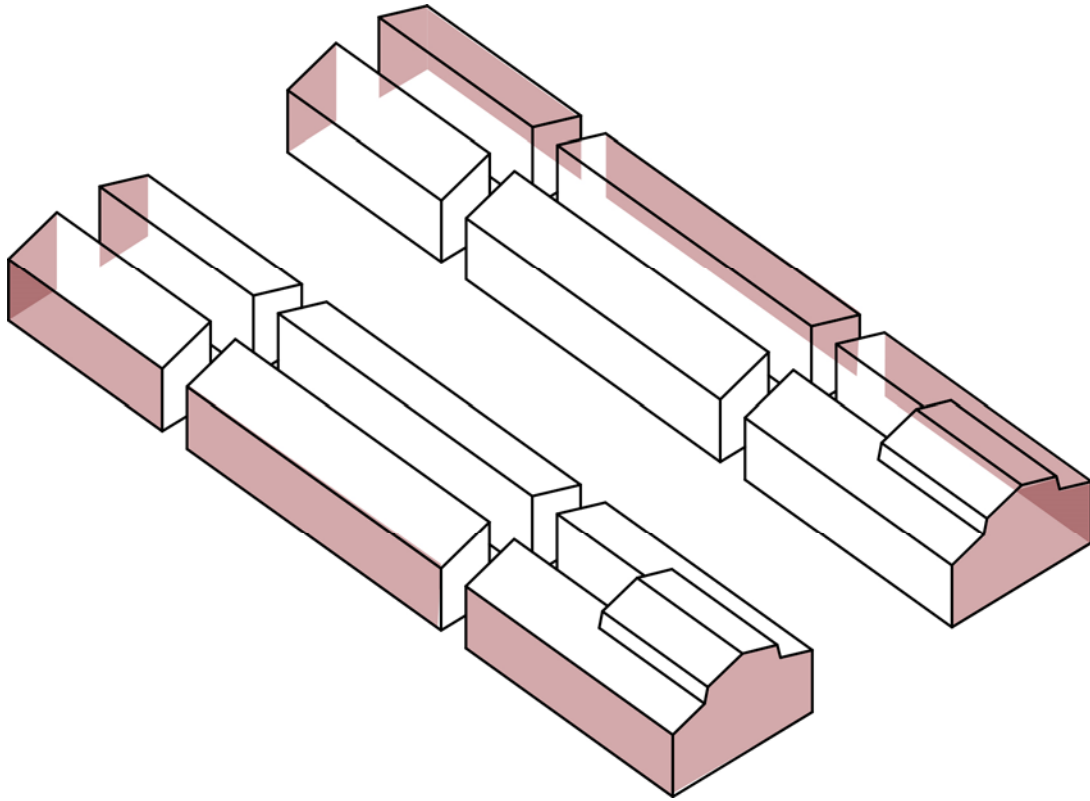

Figure 42: diagram illustrating surfaces to be clad in brick. Image by author.



Figure 43: Brick elevation detail. Image by author.

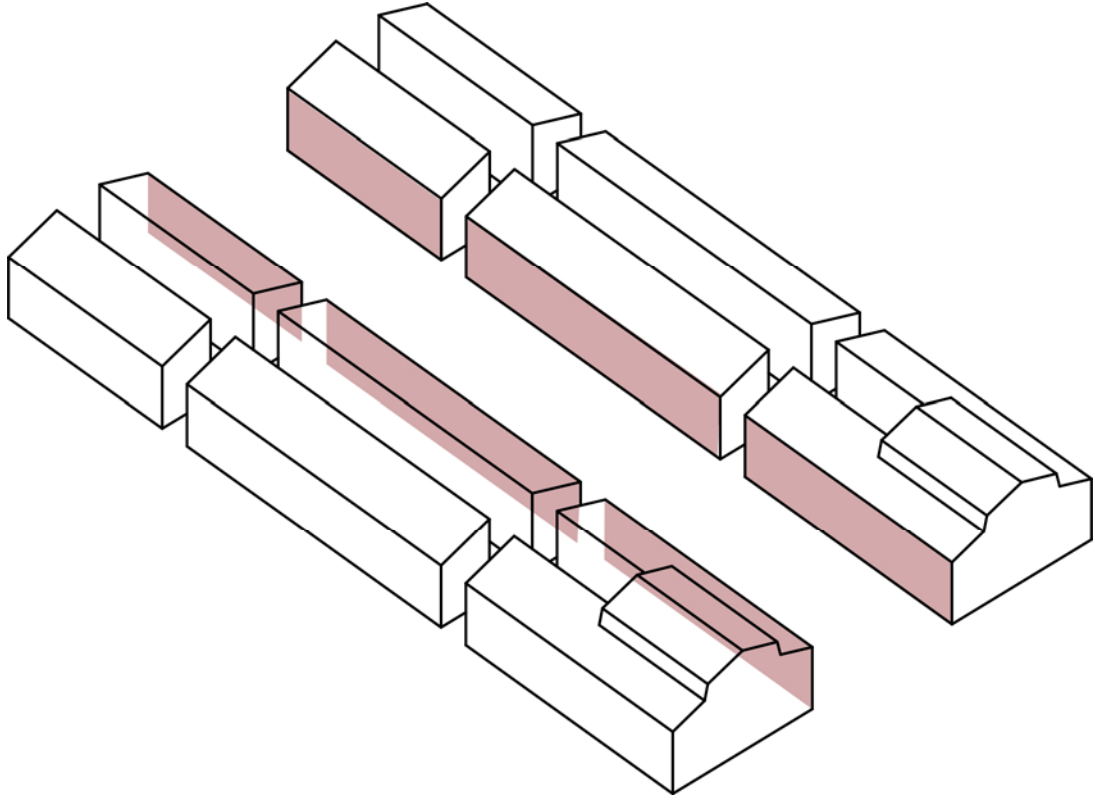

Figure 44: Diagram illustrating facade surfaces that are glazed. Image by author.



Figure 45: Elevation Detail of Glazed Facade. Image by author.

Chapter 6: Conclusions

Public Presentation

During the public presentation of this thesis, some suggestions and comments were made to improve the overall product. The first was to further interrogate the concrete channelized edge condition of the river within the city. As it was discussed in the presentation, although this large piece of infrastructure was made with the best of intentions, it ultimately failed because of subsequent floods after its implementation. Of the various schemes I presented that sought to erode the hard concrete edge between the city and the river, It was suggested that I should have examined this further and more aggressively in other parts of the city, not just the focused location that was part of my intervention.

Additionally it was mentioned that the storm water park that was created in order to organize the space adjacent to the Gautier Steel Mill could have been filled in with buildings instead of being a void. This could have been done in a way that reinforced connection to the newly created river edge to which would be the most likely place of gathering instead of the intermediate park zone. However, I know from discussions with them that my committee held the opposite view, that this space was important both as a storm water management component of the project and as a formal social space for gathering and promenade distinctly different in character from the riparian buffer edge and the spaces between the mill structures.

Overall the many iterations of tectonic expression and material usage was appreciated in how it showed a great amount of variability and potential for future reuse and repurposing of the Gautier Steel Mill.

Closing Remarks

Throughout the process of this thesis, there was a constant back and forth between different scales of focus. By going into a detailed analysis of Johnstown as it is situated within the regional context of the Rust Belt down to the detail scale of the tectonic language used to mediate the insertion of new program into the existing steel mill fabric, it was this constant shifting back in fourth in scale that lead to a cohesive design solution that Johnstown and other Rust belt cities can use in the future. This shifting of scales also enriched my learning experience by forcing me to draw conclusions and connections between different scales. Admittedly at times it was difficult for me to look past my own bias and preconceptions about Johnstown because of my family ties to the city. However, after researching precedents outside of Johnstown in similar circumstances able to form a more objective lens of inquiry with which to question and propose design solutions for Johnstown.

Bibliography

1. Mah, Alice. *Industrial Ruination, Community, and Place Landscapes and Legacies of Urban Decline*. Toronto: University of Toronto Press, 2012.
2. Cooke, Philip. *The Rise of the Rustbelt*. New York: St. Martin's Press, 1995.
3. Connolly, James J. *After the Factory: Reinventing America's Industrial Small Cities*. Lanham: Lexington Books, 2012.
4. Hollander, Justin B., and Niall Kirkwood. *Principles of Brownfield Regeneration Cleanup, Design, and Reuse of Derelict Land*. Washington: Island Press, 2010.
5. Austin, Richard L. *Adaptive Reuse: Issues and Case Studies in Building Preservation*. New York: Van Nostrand Reinhold, 1988.
6. Ryan, Brent D. *Design after Decline: How America Rebuilds Shrinking Cities*. Philadelphia: University of Pennsylvania Press, 2012.
7. Dewar, Margaret E. *The City after Abandonment*. Philadelphia: University of Pennsylvania Press, 2013.
8. Yung, Esther H.k., and Edwin H.w. Chan. "Implementation Challenges to the Adaptive Reuse of Heritage Buildings: Towards the Goals of Sustainable, Low Carbon Cities." *Habitat International*: 352-61. Accessed December 10, 2014. <http://www.sciencedirect.com/science/article/pii/S0197397511000877>.
9. Wallace, Kim E. *The Character of a Steel Mill City: Four Historic Neighborhoods of Johnstown, Pennsylvania*. Washington, D.C.: Historic American Buildings Survey/Historic American Engineering Record, National Park Service, 1989.
10. Johnstown Area Heritage Association (Pa.). *Johnstown Heritage Development Plan*. [Johnstown, Pa.?]: Johnstown Area Heritage Association, 1991.
11. Shields, Martin, and Tracey L. Farrigan. *Welcome Back Downtown: A Guide to Revitalizing Pennsylvania's Small Downtowns*. Harrisburg, Pa.: Center for Rural Pennsylvania, 2002.
12. Leinberger, Christopher B. *Turning around Downtown Twelve Steps to Revitalization*. Washington, D.C.: Brookings Institution Center on Urban and Metropolitan Policy, 2005.
13. "Home." Home. Accessed December 13, 2014. <http://www.jaha.org/>.
14. "JAHA Mission." JAHA Mission. Accessed December 10, 2014. <http://www.jaha.org/AboutJaha/JAHAMission.html>.
15. Papa, Ronald. "Cambria Iron Works." [Http://www.cmu.edu/steinbrenner/brownfields/Case Studies/](http://www.cmu.edu/steinbrenner/brownfields/Case%20Studies/). January 1, 2008. Accessed December 10, 2014. [http://www.cmu.edu/steinbrenner/brownfields/Case Studies/pdf/cambria iron works case study.pdf](http://www.cmu.edu/steinbrenner/brownfields/Case%20Studies/pdf/cambria%20iron%20works%20case%20study.pdf).
16. Huxtable, Ada Lousie. "Lessons in Healing the Cities Scars." *The New York Times*, May 27, 1973.
17. Yusuf, Shahid, and Kaoru Nabeshima. *Postindustrial East Asian Cities: Innovation for Growth*. Palo Alto, CA: Stanford Economics and Finance ;, 2006.

18. Smith, Stephen J. *Recreation and Tourism as a Catalyst for Urban Waterfront Redevelopment: An International Survey*. Westport, Conn.: Praeger, 1995.
19. Burchell, Robert W., and David Listokin. *The Adaptive Reuse Handbook: Procedures to Inventory, Control, Manage, and Reemploy Surplus Municipal Properties*. New Brunswick, N.J.: Rutgers University, Center for Urban Policy Research, 1981.
20. Kirkwood, Niall. *Manufactured Sites: Rethinking the Post-industrial Landscape*. London: Spon Press, 2001.
21. Levin, Miriam R. *Urban Modernity: Cultural Innovation in the Second Industrial Revolution*. Cambridge, Mass.: MIT Press, 2010.
22. Russ, Thomas H. *Redeveloping Brownfields: Landscape Architects, Planners, Developers*. New York: McGraw-Hill, 2000.
23. Tumber, Catherine. *Small, Gritty, and Green: The Promise of America's Smaller Industrial Cities in a Low-carbon World*. Cambridge, Mass.: MIT Press, 2012.
24. Bartsch, Charles, and Elizabeth Collaton. *Brownfields: Cleaning and Reusing Contaminated Properties*. Westport, Conn.: Praeger, 1997.
25. Se, Mario. *The Social Sustainability of Cities Diversity and the Management of Change*. Toronto, Ont.: University of Toronto Press, 2000.
26. Pierson, John. *Rebuilding Community: Policy and Practice in Urban Regeneration*. New York: Palgrave, 2001.
27. Bowen, William M. *The Road through the Rust Belt: From Preeminence to Decline to Prosperity*.
28. Fukuyama, Francis. *The Great Disruption: Human Nature and the Reconstitution of Social Order*. New York: Free Press, 1999.
29. "Johnstown, Pennsylvania." Wikipedia. January 1, 2014. Accessed December 12, 2014. <http://www.wikipedia.org/>.
30. "Johnstown Redevelopment Authority." Johnstown Redevelopment Authority. January 1, 2009. Accessed December 12, 2014. <http://www.johnstown-redevelopment.org/about.htm>.
31. Segedy, Jason. "What's in a Number? Confronting Urban Population Decline." What's in a Number? Confronting Urban Population... November 5, 2014. Accessed December 13, 2014. <http://thestyle1972.tumblr.com/post/101874810155/whats-in-a-number-confronting-urban-population>.
32. Fox, Radhika, and Miriam Lute. *To Be Strong Again: Renewing the Promise in Smaller Industrial Cities*. Oakland, CA: Policy Link, 2008.
33. "Rust Belt." Wikipedia. Accessed December 13, 2014. http://en.wikipedia.org/wiki/Rust_Belt.