

ABSTRACT

Title of Document: AN INTEGRATED BUS-BASED
PROGRESSION SYSTEM FOR ARTERIALS
HAVING HEAVY TRANSIT FLOWS

Yao Cheng, Master of Science, 2014

Directed By: Gang-Len Chang
Professor
Department of Civil and Environmental
Engineering

Conventional Transit Signal Priority (TSP) controls often reach the limitation for arterials accommodating heavy bus flows since the priority control function can significantly increase the delay at minor streets. Under such conditions, a proper signal coordinated plan that aims to offer progression for buses is one potentially effective strategy. This study proposes a bus-based progression system to reduce the delay of buses on local arterials experiencing heavy bus volume. The proposed model is capable of providing bus-progression bands under various traffic conditions, which take into account the stochastic nature of bus dwell time and the capacity of bus stops. The trade-off between passenger-car and bus-based progression bands and the selection logic under different traffic compositions have been also investigated in this study. The results of extensive simulation experiments have confirmed the proposed model's effectiveness in reducing the bus passenger delay and the average passenger-car delays under various traffic conditions.

AN INTEGRATED BUS-BASED PROGRESSION SYSTEM FOR ARTERIALS
HAVING HEAVY TRANSIT FLOWS

(Draft and under further revision and editing)

By

Yao Cheng

Thesis submitted to the Faculty of the Graduate School of the
University of Maryland, College Park, in partial fulfillment
of the requirements for the degree of
Master of Science
2014

Advisory Committee:
Professor Gang-Len Chang, Chair
Professor Lei Zhang
Professor Cinzia Cirillo

© Copyright by

Yao Cheng

2014

Acknowledgements

During the past months I was composing my Master thesis, so many people offered me kindly help that I have to express my sincere acknowledgment.

First, I am very grateful to my advisor, Professor Gang-Len Chang. I can hardly complete the thesis with such a quality without his strong and continuous support. In the past year, his professional directions and useful suggestions kept influencing my work and helped improving the comprehensiveness of my thoughts. When I was confused or stuck, it is his thoughtful and wise advice that directs me move on the right track for my research.

Second, I would like to show my appreciation to Professor Lei Zhang and Professor Cinzia Cirillo, who served as my thesis committee members. I thank them for their precious time and expertise to enhance my study.

I should also thank my dear colleagues and friends for helping me during the past years. This will be a great opportunity to give my special thanks to Xianfeng Yang, who always guide me on my study. I really appreciate his effort whenever I met difficulties. My progress would not be so significant without his selfless help. I also want to thank Yang Lu, Sung Yoon Park and other members in our group. The cooperative atmosphere in our group motivates me to work hard every day and to fully devote myself. I feel very lucky to be in such an excellent group with my dear colleagues. I may not mention all my friends I have fortunately met at University of Maryland, College Park, but they will always be remembered and appreciated for being accompany with me.

Last, but not the least, I would like to thank my beloved parents. Their love and support is always the most important incentive for me to move forward to a better life.

Table of Contents

ACKNOWLEDGEMENTS	II
TABLE OF CONTENTS.....	III
LIST OF TABLES	IV
LIST OF FIGURES	V
CHAPTER 1: INTRODUCTION	1
1.1. STUDY BACKGROUND.....	1
1.2. PRIMARY OBJECTIVE	2
1.3. ORGANIZATION OF THE THESIS	3
CHAPTER 2: LITERATURE REVIEW	4
2.1. TRANSIT SIGNAL PRIORITY	4
2.2. SIGNAL PROGRESSION.....	8
2.3. BUS PROGRESSION	11
2.4. SIGNAL PROGRESSION WITH UNCERTAINTY.....	12
2.5. SUMMARY	12
CHAPTER 3: PROBLEM NATURE AND MODELING FRAMEWORK	14
3.1. BUS DWELL TIME	14
3.2. DWELL TIME VARIANCE	15
3.3. CAPACITY OF THE BUS STOPS	18
3.4. COMPETITION BETWEEN BUS PROGRESSION AND PASSENGER CAR PROGRESSION BANDS	19
3.5. MODELLING TASKS	20
CHAPTER 4: METHODOLOGY	24
4.1. DETERMINISTIC BUS PROGRESSION MODEL	25
4.2. EVALUATION MODULE	33
4.3. INTEGRATED MODEL	43
4.4. SUMMARY	48
CHAPTER 5: CASE STUDY.....	50
5.1. CASE DESIGN	50
5.2. MODEL EVALUATION.....	53
5.3. SENSITIVITY ANALYSIS.....	62
CHAPTER 6: CONCLUSIONS AND FUTURE STUDY.....	66
6.1. CONCLUSIONS.....	66
6.2. FUTURE RESEARCH	67
BIBLIOGRAPHY	68

List of Tables

TABLE 1.	MODEL NOTATIONS	24
TABLE 2.	ADJUSTED VISSIM PARAMETERS	53
TABLE 3.	OFFSETS (SECONDS) CALCULATED WITH MODELS-2,3 AND 4.....	53
TABLE 4.	OPTIMIZATION RESULTS OF MODEL-3 WITH DIFFERENT SETS OF PARAMETERS.....	57
TABLE 5.	ADJUSTED LOADING FACTORS AND PASSENGER RATIOS BETWEEN TWO TYPES OF VEHICLES.....	63

List of Figures

FIGURE 1.	SIGNAL PROGRESSION BETWEEN TWO ADJACENT INTERSECTIONS.....	9
FIGURE 2.	GRAPHICAL ILLUSTRATION OF BUS DWELL TIMES IN THE PROGRESSION BAND DESIGNED FOR PASSENGER CARS....	15
FIGURE 3.	DISTRIBUTION OF BUS DWELL TIMES COLLECTED FROM 11/01/2012 TO 11/07/2012.....	16
FIGURE 4.	GRAPHICAL ILLUSTRATION OF THE STOCHASTIC NATURE OF BUS DWELL TIME.....	17
FIGURE 5.	VARIABLE GREEN BANDS USING BUS STOPS AS CONTROL POINTS.....	18
FIGURE 6.	BUS QUEUE SPILLOVER AT THE NEAR-SIDE BUS STOPS.....	19
FIGURE 7.	COMPETITION BETWEEN THE BUS BAND AND THE PASSENGER CAR BAND.....	20
FIGURE 8.	MODELLING FRAMEWORK.....	23
FIGURE 9.	IMPACT OF BUS DWELL TIME UNCERTAINTIES	31
FIGURE 10.	GRAPHICAL ILLUSTRATION OF RELATION BETWEEN PROGRESSION BANDS AT TWO NEIGHBORING INTERSECTIONS.....	35
FIGURE 11.	STOCHASTIC ANALYSIS FOR TWO ADJACENT INTERSECTIONS.....	40
FIGURE 12.	FLOWCHART FOR USING THE DETERMINISTIC MODEL WITH STOCHASTIC ANALYSIS TO IDENTIFY THE OPTIMAL BUS-PROGRESSION SOLUTION	42
FIGURE 13.	FLOW CHART OF THE INTEGRATED MODEL	48
FIGURE 14.	ILLUSTRATION OF THE TARGET ARTERIAL FOR EXPERIMENTAL ANALYSIS	50
FIGURE 15.	PROGRESSION BANDS GENERATED BY DIFFERENT MODELS	56
FIGURE 16.	SIMULATION RESULTS BY MODEL-3 WITH VARYING PARAMETERS AND BY MODEL-4	58
FIGURE 17.	COMPARISON OF MODEL'S PERFORMANCE MEASURES	61
FIGURE 18.	MODEL-5'S PERFORMANCE MEASURES WITH DIFFERENT PASSENGER RATIOS	65

Chapter 1: Introduction

1.1. Study Background

As an effective way to mitigate urban traffic congestion, transit system serves as a key mode in many metropolitan areas around the world. Due to the high capacity of transit vehicles, the promotion of transit systems can help minimize the number of passenger cars in urban networks and consequently reduce the overall network congestion. From the green transportation perspective, transit systems can significantly contribute to reduction in the energy resources and vehicles' emissions.

However, a transit system can be effective only if it is well designed and effectively operated. More specifically, the most critical design issue at the operation level is to minimize the delays and frequent stops experienced by bus riders. Both the delay variance and stop frequency may consequently affect the schedule reliability of a transit system and commuters' willingness to select such a transportation mode.

Most existing studies in contending with such a vital issue is to offer transit vehicles with conditional or unconditional priority via either active or passive signal control. However, such priority controls are effective only if transit vehicles constitute a small percentage of the arterial traffic flows. Otherwise, the negative impacts of such priority controls on the cross-street traffic and on the disruption of arterial signal progress may increase significantly with the number of priority activation calls. Hence, the inevitable dilemma encountered by many transportation professionals is how to incentivize commuters to take the transit mode with less

frequent stops and reduced delays, but not at the unbearable cost of passenger car users on both the same arterial and the cross-street from the network perspective.

Since signal coordination is the most commonly-used arterial control strategy for vehicle progression and minimization of traffic delay, one potential method to couple with the dilemma is to properly integrate the transit-oriented signal priority design and passenger-car-favored arterial progression system. Ideally, such a control system shall be able to account for all key operational characteristics of a bus system, and to provide either a bus-band or passenger-based progression system in different times of a day, based on the total traffic volume and bus percentage in the total flows.

1.2. Primary Objective

The objective of this study is to develop a bus-based arterial progression system that accounts for key bus operational features, such as dwell time at a stop, the dwell time variance, the capacity of a bus stop, and the balance between operational benefits of buses and passenger cars. Such a model shall also be capable of balancing the benefits between both passenger-car and transit users, and minimizing the potential impacts to traffic on the cross-streets. In view of the trade-off between maximizing the progression benefits of transit vehicles and passenger cars, this study has further developed a supplemental method to concurrently offer progression bands to both the transit and passenger-car flows.

1.3. Organization of the Thesis

The rest of this thesis is organized as follows. Chapter 2 will review the literature related to design of Transit Signal Priority (TSP) and arterial signal progression. Chapter 3 analyzes the features of transit vehicles and critical issues to be addressed in the model development. A detailed illustration of the modelling methodology and formulations will be introduced in Chapter 4. Chapter 5 summarizes the evaluation results of extensive numerical experiments and sensitivity analysis of key parameters. Conclusions and future research directions are reported in Chapter 6.

Chapter 2: Literature Review

Over the past decades, both transit signal priority and signal progression have been extensively studied in the literature. A brief review of key models in each category is presented below.

2.1. Transit Signal Priority

To improve a transit system's reliability, transportation researchers have worked on various advanced methods and technologies for several decades. Transit Signal Priority (TSP), recognized as a promising method to reduce bus delay in urban networks, was first developed in late 1960s (Smith, 1968). TSP is an operational strategy that facilitates the movement of buses and allows buses to pass a target intersection without a stop by adjusting signal timings. Based on whether or not the priority control is in response to the presence of buses, a TSP control system may be classified as an active TSP or a passive TSP.

Active TSP

Active TSP generally needs to detect the arrival of buses with the sensors near the intersection. Under a low bus demand condition, many studies have demonstrated the effectiveness of active TSP in reducing bus travel time over an arterial. Most existing Active TSP strategies can be categorized into rule-based and model-based methods.

Unconditional TSP control, as one of the earliest rule-based strategies, is to extend green time or truncates the red phase upon the detection of an arriving bus (Ludwick & John, 1974). This method has been proven with simulation experiments to be effective on improving the bus efficiency, but not significantly interrupting the traffic on side streets if the bus demand is not very high. To minimize the potential impact to side street traffic, some rules have been developed to limit the green time extension (Dion & Hesham, 2005). By adopting these rules of keeping the cycle length unchanged and limiting the number of priority calls in a single cycle, unconditional TSP strategies can be applicable to arterials in need to accommodate heavy bus flows, but keeps the side street from serious interruptions.

Conditional priority is another kind of rule-based methods, which takes into account the actual bus presence and readiness in order to minimize the impact on other type of vehicles. (Ma & Yu, 2007; He *et al.*, 2011; Kulash, 1971; Ling & Shalaby, 2004; Altun & Furth, 2009; Yan *et al.*, 2009) Basically, it only grants priorities to buses behind the schedule, thus may ignore some requests from some early-arriving buses. Similarly, some rules have been developed for conditional TSP to constrain the frequency of activating priority control, based on the ridership of the buses or the priority decisions in previous cycles. (Evans & Skiles, 1970; Tarnoff, 1975; MacGowan & Fullerton, 1979; Allsop, 1977; Cottinet *et al.*, 1980; Zhou & Gan, 2009; Gallivan *et al.*, 1980; El-Reedy & Ashworth, 1978; Cooper *et al.*, 1980; Bowen *et al.*, 1994) These rule-based methods offer the requested priority controls, based on empirical results, rather than rigorous computation. Such models are easy to

implement in practice, but may not yield the optimal level of performance. (Smith, *et al.*, 2005; Balke *et al.*, 2000; Janos & Furth, 2002; Satiennam *et al.*, 2005)

Model-based methods, generally more complex than rule-based methods, intend to grant the priority decisions, based on some performance measures computed from the detected bus locations, bus operation conditions, and nearby traffic conditions. (Ma *et al.*, 2010; Lin *et al.*, 2013a; Lin *et al.*, 2013b; Lin *et al.*, 2013c) Such methods try to optimize the performance of buses or all kinds of vehicles by quantitatively evaluating the potential effect resulting from a priority decision. The objectives can be to minimize the total bus delay and the total person delay (Lin *et al.*, 2013). In addition, most model-based methods are more flexible for extension to traffic networks experiencing various levels of congestion.

Passive TSP

However, on those arterials experiencing heavy bus volumes, the TSP control strategy may reach its limitation since: 1) most TSP controls are operated at the isolated intersection level, which is not sufficient to facilitate the progression of buses over consecutive intersections, and 2) the TSP system will yield significant negative impacts to non-priority intersection approaches due to the frequently calls by the signal priority control. Though various existing methods reported in the literature intend to reduce the impacts to the non-priority approaches by adding operational rules or balancing the benefits to all types of vehicles, the conventional TSP strategies remains ineffective in minimizing the negative impacts on side-street-traffic flows if the bus volume in the primary arterial incurs frequent activation of priority control. This is why most TSP strategies are simulated or tested under the scenarios of

relatively low bus volume. Hence, a passive control strategy may serve as a better way to deal with arterials accommodating heavy bus flows.

Contrast to active TSP control, passive control strategies do not explicitly recognize the presence of buses, but predetermine the signal timings by taking into account the percentage of bus volume in the total traffic flows. (Machemehl, 1996; Zhang *et al.*, 2004; Ji *et al.*, 2005; Feng *et al.*, 2007; Mirchandani *et al.*, 2001) These strategies do not change the signal timings upon the arrival of a bus or penalize vehicles on the cross streets by extending the green time, but programming the signal in a way that may be favorable to bus movements. As such, the passive control strategies do not interrupt traffic in the non-priority approaches. Moreover, since it needs not to detect the arrival of buses, the deployment of passive control strategies does not incur the cost of installing and operating bus surveillance systems. .

As one of the pioneering researchers on this subject, Urbanik (1977) developed four possible ways to change the signal plan for one or a group of intersections to favor the bus flows. Their proposed strategies include adjustment of cycle length, splitting of phases, area-wide timing plans, and metering of vehicles. Such methods generally require only changes at the control and operational levels, but nearly demand no capital investment. Garrow and Machemehl (1997) utilized TRAF-NETSIM as a simulation tool to test the effectiveness of shortening the cycle length and splitting phase at both isolated intersections and local arterials. Their underlying logic is that a long cycle length is generally designed to maximize vehicle throughput along arterials since it decreases the intersection's lost time and can generally widen the progression bands for through movements, but at the cost of

increasing the stop delay. Hence, a short cycle length may serve as a passive transit priority strategy to decrease the stop delay of transit vehicles at intersections. The concept of splitting phase is to separate the green phase in a cycle for the transit movement into two separate sub phases so that a bus encountering a red phase will only wait for a shorter period before receiving its green indication. By doing so, it is expected that the intersection capacity will be reduced due to the additional lost time. The relationship between the departure frequency of transit vehicles and cycle lengths of signalized intersections are discussed by Ma and Yang (2007). They concluded that providing priority to buses is much easier if the departure headway is a multiple of half cycle length. They further used simulation to argue that both active and passive strategies can be applied to BRT (Bus Rapid Transit) systems to decrease the delay and headway deviation.

2.2. Signal Progression

As is well recognized, signal progression strategies are designed to allow some vehicles to pass some consecutive intersections without encountering red phases. (Chang E. C. P *et al.*, 1988; Hisai M., 1987; Leuthardt H. R., 1975; Little J. D. C, 1966; Liu C.C., 1988; Tsay H.S. & Lin L.T., 1988; Wallace C.E and Courage K.G., 1982;) The band in the time-space diagram, shown in Figure 1, is called a green band, where bandwidth is defined as the portion of a green phase during which vehicles travelling at the designed progression speed can smoothly traverse over all intersections within the control boundaries. (Morgan and Little, 1964). A well-designed signal progression system may reduce accidents since the vehicles arriving

at each signal are mostly in platoons and thus less likely to incur rear-end collisions during the red phase. (Gartner et al., 1990).

Since the bandwidths may determine the number of vehicles benefiting from the signal control, researchers have focused on design of various strategies for maximizing the progression bandwidths for several decades. The core logic of such studies is to optimize the signal offsets over an arterial with a common cycle length, based on the estimated travel time between each pair of adjacent intersections. The pioneering work that sets the foundation for arterial signal progression was first presented by Morgan and Little (1964).

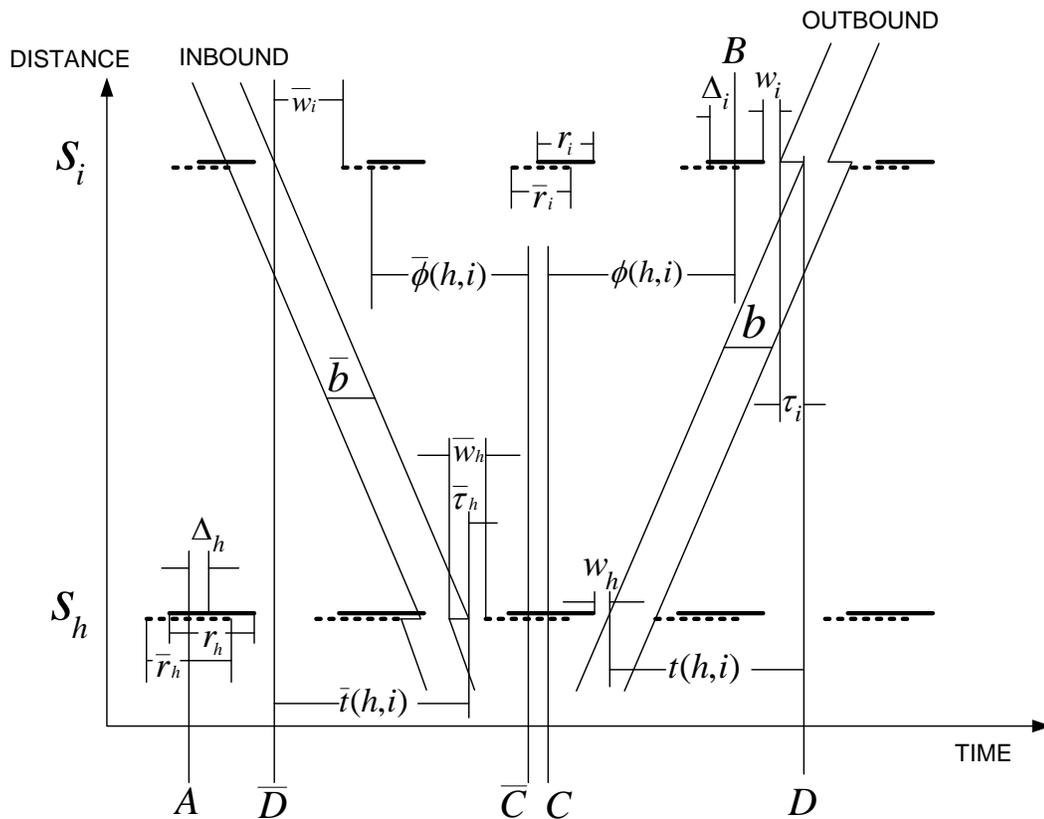

Figure 1. Signal progression between two adjacent intersections

Little et al. (1981) further developed a more efficient way to find the maximum green band with mixed-integer linear programming. A program, called MAXBAND (Chang E.C.P. et al., 1988; Cohen S.L., 1983), was also designed to handle this problem based on their methodology. This method intends to maximize the sum of outbound and inbound bandwidths with a series of constraints. The core of their loop integer constraints is that (See Figure 1) the links S_h to S_i and S_i to S_h form a loop and that the sum of times around the loop is an integer number of cycles. This can be described with the following equation:

$$\phi(h,i) + \bar{\phi}(h,i) + \Delta_h + \Delta_i = m(h,i)$$

where $m(h,i)$ is called the loop integer representing an integer number of signal cycles. Also, some constraints are developed to make sure that the bands use only the green time. Their more advanced model also permits the optimization process to account for when the left turn phase will occur with respect to the through green phase within a cycle. This may allow any combination of leading and lagging phases through all intersections along the arterials. In addition, one may favor one direction for progression since the volumes may be not balanced between the two directions. This can be specified with the following objective function and constraint:

$$\begin{aligned} \max \quad & b + k\bar{b} \\ (1-k)\bar{b} \geq & (1-k)kb \end{aligned}$$

where k is defined as the target ratio of inbound to outbound bandwidths, which are defined by the user. When k equals 1, it captures the equality between the outbound and inbound bandwidths. Such models can be solved with linear programming.

Gartner et al. (1990) further developed a multi-band approach to optimize arterial traffic signals under various traffic conditions. In the MULTIBAND formulations, each band is continuous, but varies in the width at different links. The bandwidth is defined between each pair of adjacent signals in each direction, and the constraints are set to make sure that the center lines of bands are continuous. With different weighting factors for the bandwidths on different links, MULTIBAND can generate better signal plans and yield lower delays for arterials experiencing the volume difference between neighboring links.

2.3. Bus Progression

Despite the large body of literature in TSP and signal progression over the past decades, very few researchers have explored the potential of offering signal progression for buses. Among those, Lin et al. (2013) has taken some bus operational features into account, and developed a passive transit signal priority control strategy for urban arterials. They added the estimated dwell time to the computed travel time between two intersections, if a bus stop is located on that link. Also the queue clearance time for transit vehicles, which may vary with the presence of a bus exclusive lane, has also been considered in their models. They also analyzed the impact of bus stops on the green bands by balancing the passenger car bandwidth with the bus bandwidth. Although they considered the potential impact of the bus dwell time, only an estimated dwell time was substituted into the mixed-integer formulations. However, as the bus dwell time may vary from one stop to the next, providing reliable estimates for this critical variable is the key to the effectiveness of such bus progression methods.

2.4. Signal Progression with Uncertainty

To account for the variance in traffic conditions, Li (2013) developed a two-phase approach to find an optimal signal plan for urban arterials. In the first phase, He employed the MAXBAND models with perturbation by a parameter are solved to produce a series of suboptimal plans. The second phase applies the Monte Carlo method to simulate the random progression time, and then rank the generated plans with reliability. The core logic of this method is grounded on the property of MAXBAND that allows a slight shift of the red phase's center in each cycle, but not influences the progression band.

2.5. Summary

This chapter has reviewed the existing studies on transit signal priority, signal progression, bus progression, and uncertainties caused by critical associated factors. Overall, one may conclude that active TSP strategies are more effective in response to the fluctuation of bus volumes since they only grant extra green time to the buses upon their arrivals. However, such strategies may not be effective for traffic flows comprising high bus volume due to the negative impacts to non-priority streets and interference to the signal progression design. Therefore, a passive control strategy that can facilitate the bus progression but without significant negative impacts to the side-street traffic, could be one of the promising strategies. However, an effective passive model for bus progression shall account for the following key issues: (1) bus dwell time and its uncertainty at each arterial's bus stops, (2) capacity constraints at each bus stop, and (3) the potential negative effect to passenger-car flows on arterials.

Development of effective signal progress models that can address the aforementioned critical issues thus constitutes the core of this study.

Chapter 3: Problem Nature and Modeling Framework

3.1. Bus Dwell Time

As stated in the previous chapter, one of the core methods to design signal progression is maximizing the green bandwidth for traffic flows so as to facilitate vehicles to pass the target arterial segment without signal delays. Examples of existing algorithms for signal progression include MAXBAND (Little et al., 1981) and MULTIBAND (Gartner et al. 1990). However, since these algorithms mainly focus on passenger cars, their provided bands cannot accommodate transit vehicles due to the impact of bus dwell time as shown in Figure 2. Notably, the band indicates with dashed lines are designed for passenger cars, but the buses may miss the band after dwelling at the bus stop. When the bus arrives at the departing intersection, it may encounter a red phase. Therefore, an algorithm that accounts for the impact of bus dwell time should be applied when designing a bus progression system.

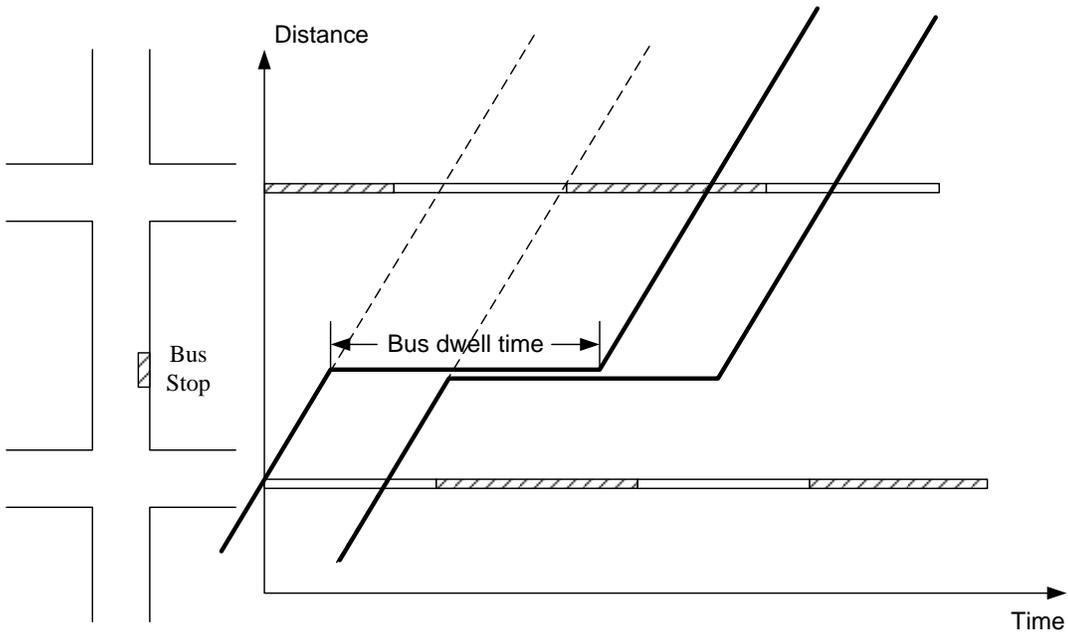

Figure 2. Graphical illustration of Bus dwell times in the progression band designed for passenger cars

3.2. Dwell time variance

As discussed in the last chapter, existing algorithms for bus progression generally assume a deterministic dwell time. However, in practice, bus dwell time is affected by the passenger demands at bus stops as shown in Figure 3 which shows a dwell time data sample from Jinan, China. In this example, the dwell time ranges from 1 second to 72 seconds at stop 3, and from 1 second to 52 seconds at stop 4.

Hence, the stochastic nature of bus dwell times may cause the bus to miss a band designed with a deterministic dwell time. Figure 4 shows the trajectory of two buses with dashed lines, and a bus band designed with a deterministic dwell time by solid lines. The estimated dwell time for bus-1 is longer than the actual one, but is shorter for bus-2. As illustrated in the figure, bus-1 receives the green phase at the downstream intersection while bus-2 encounters the red phase.

Due to the dwell time variance, it may not be possible to ensure that all buses from the arriving band will stay within the departing band after departing from the stops. In view of the impact of bus dwell times on the progression band, it is essential that the stochastic nature of bus dwell time be incorporated in the design of a bus-based progression system.

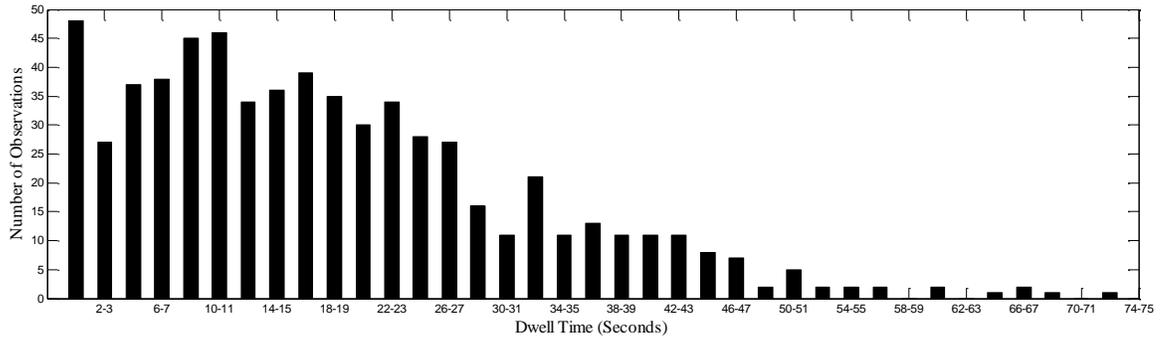

(A) Bus dwell times at stop-3 of Jiefang Rd, Jinan, China

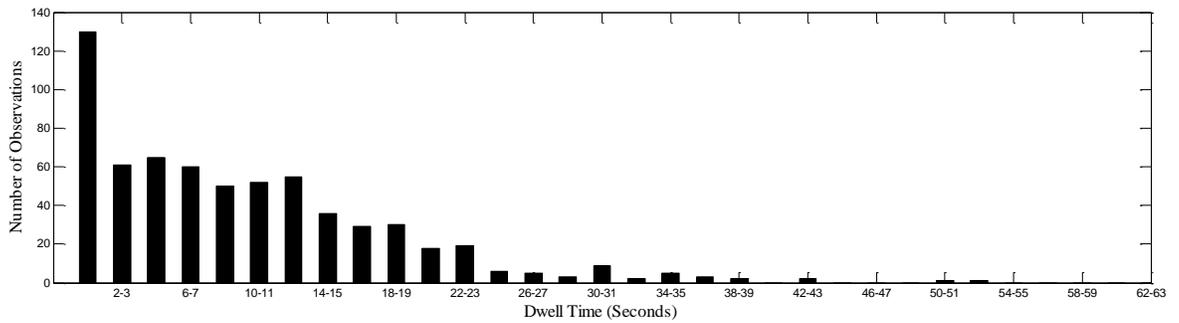

(B) Bus dwell times at stop-4 of Jiefang Rd, Jinan, China

Figure 3. Distribution of Bus Dwell Times Collected from 11/01/2012 to 11/07/2012

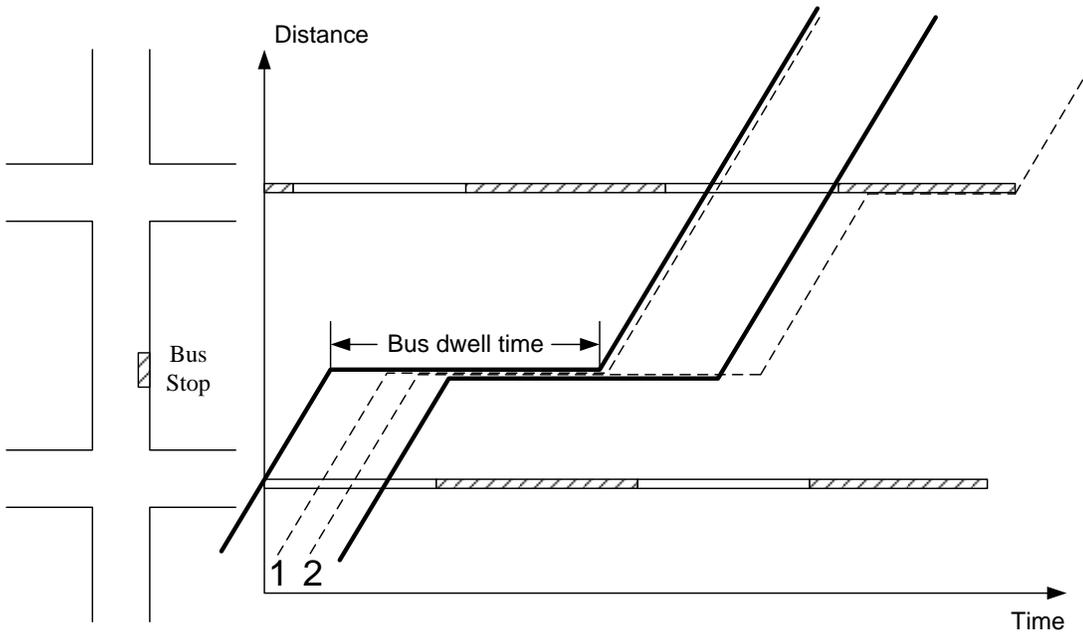

Figure 4. Graphical illustration of the stochastic nature of bus dwell time

To overcome this issue, this study introduces a variable-band progression model which allows the bandwidth to vary between stations. As shown in Figure 5, by specifying different arriving and departing bandwidths for a bus stop, one can design a robust bus progression plan that accounts for the stochastic nature of bus dwell time. Different from the MULTIBAND model which takes each intersection as a control point, the proposed model takes bus stops between two intersections as control points.

Conceivably, there exists some interrelations between two adjacent bands (i.e., arriving and departing bands from a bus stop) that may influence the overall performance of the system's progression. For example, a wider departing green band can increase its probability of receiving buses departing from the stops, while a larger arriving band will allow more buses to experience the designed signal progression.

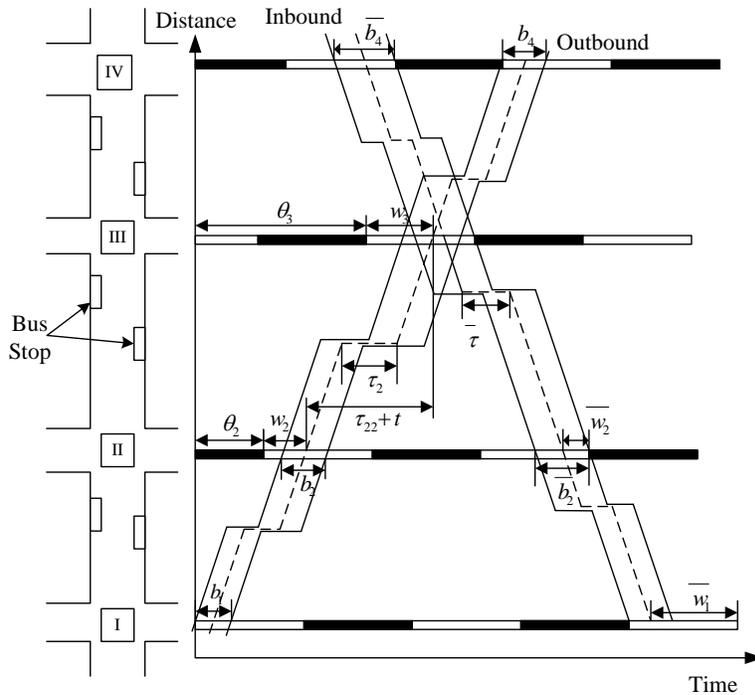

Figure 5. Variable green bands using bus stops as control points

3.3. Capacity of the bus stops

For both operational and safety concerns, another critical issue to be addressed in design of a bus progression system is the limited storage capacity at bus stops. Figure 6 presents an arterial segment with one far-side bus stop. When the number of arriving buses within a short time period exceeds the storage capacity of a bus stop, the queuing buses may spill back to the nearby intersection and thus block the traffic flows to the target intersection. More specifically, the spillover may result in the following operational and safety issues: 1) causing potential safety hazard at the intersection near the bus stop, 2) increasing the delay for those buses blocked by the spillback flows, 3) contributing to the bus dwell time uncertainty; and 4) further delaying vehicles for other movements. Hence, the excessive bus queue at a bus stop should be prevented. In design of a bus-based progression system, one shall preset an

upper bound for the bus bandwidth so that the number of buses arriving at a bus stop in a short period shall be limited and be calculated based on the bus arrival rate.

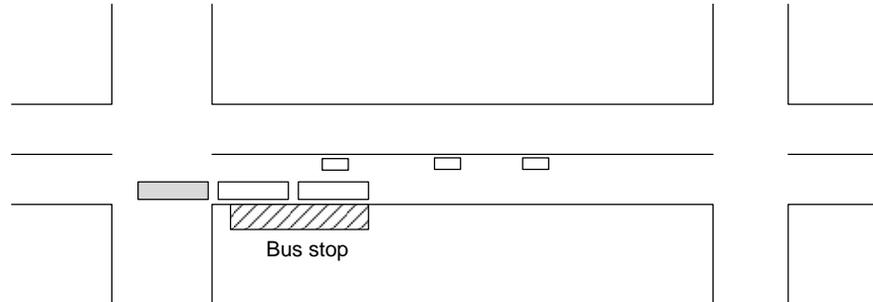

Figure 6. Bus Queue Spillover at the Near-Side Bus Stops

3.4. Competition between bus progression and passenger car progression bands

Note that to improve the progression efficiency on local arterials, the design of a bus-based band is necessary to concurrently account for the operational benefits of passenger car flows. If the progression is only designed for transit vehicles, the passenger cars may not be benefited from such a design. Figure 7 illustrates an example of signal design at two adjacent intersections. Though buses may be benefited from this design, passenger cars will experience frequent stops when traversing over those two intersections. In general, there exists a tradeoff between providing progression bands for transit vehicles and passenger cars. Therefore, a model that is able to deal with such a tradeoff shall have a better potential for use in practice than those solely focusing on one type of vehicles.

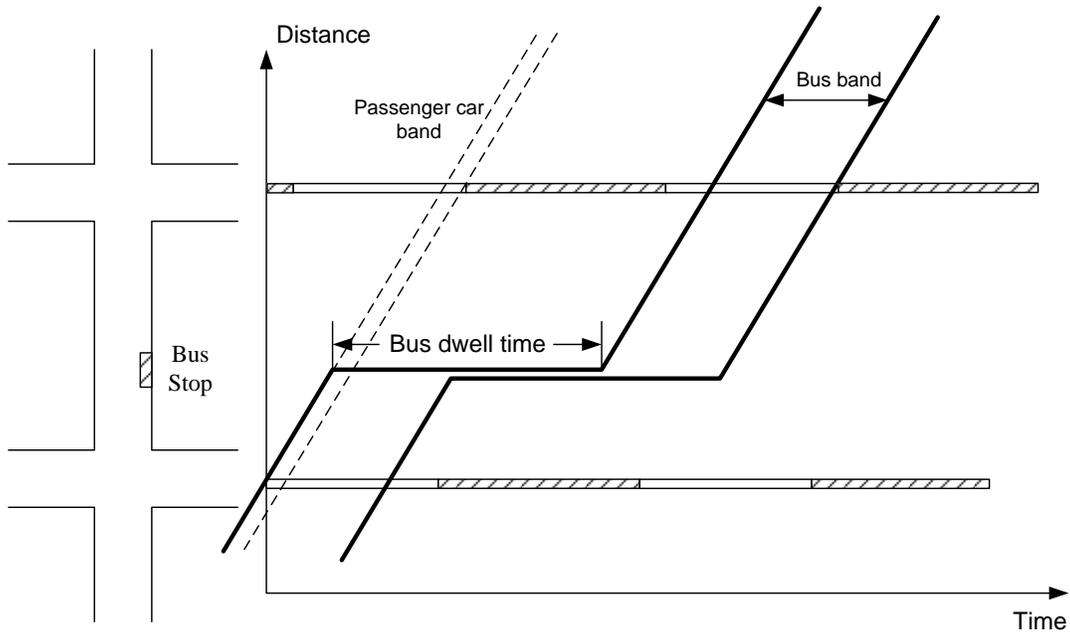

Figure 7. Competition between the bus band and the passenger car band

3.5. Modelling tasks

In summary, there are four critical issues that need to be addressed in design of a bus progression system are stated below:

- 1) How to incorporate the bus dwell time at bus stops when formulating the signal progression models;
- 2) How to account for the variance of bus dwell time when estimating the progression speed between adjacent intersections;
- 3) How to consider the capacity of a bus stop in the optimization process so as to prevent the occurrence of queue spillover and to minimize the potential impact to the nearby intersections; and

- 4) How to deal with the competition between the bus band and the passenger car band in design of signal progression.

In response to the aforementioned issues, the proposed system for bus progression should have the following functions:

- 1) Shifting the band at bus stops to accommodate the bus dwell time;
- 2) Allowing the bandwidths to vary between intersections;
- 3) Ensuring a relatively high probability that a bus will keep in the band after it dwells at a stop;
- 4) Limiting the bandwidths for buses, and controlling the number of buses arriving within one cycle; and
- 5) Balancing the passenger car bandwidth with the bus bandwidth so as to minimize the overall passenger delay in the network

To contend with above issues, the remaining study presented in the next chapter will focus on formulating the following models:

- **A deterministic model.** Only bus progression is considered in this model, not for passenger cars. Following the core concept of MAXBAND, a Mixed-Integer Linear Programming model will be developed to account for the impact of bus dwell times and the constraint of bus stop capacity in design of the progression band. It is capable of dealing with the first two and the fourth functions listed above. Nevertheless, this model cannot fully optimize the

signal plan and yield the bus progression since MILP cannot reflect the stochastic nature of some critical factors.

- **An evaluation module.** By adjusting a parameter in the deterministic model, one can obtain multiple sub-optimal solutions by running multiple MILPs. The solutions of these sub-optimal strategies may not fully respond to the need of actual traffic conditions. Hence, taking both the stochastic nature of bus dwell time and the well-defined deterministic relations between intersections shall constitute one promising alternative for design of an effective bus-progression system.
- **An integrated model.** To address the inevitable conflicts between a bus-progression and passenger-car bands, this study has further proposed an integrated model that can concurrently account for the benefits of both passenger cars and transit vehicles.

The deterministic model and the evaluation module work together as a complete method to design signal progression for buses. To consider the benefit of passenger cars in the progression design, the deterministic model and the evaluation module will be enhanced. The enhanced modelling framework is shown in Figure 8.

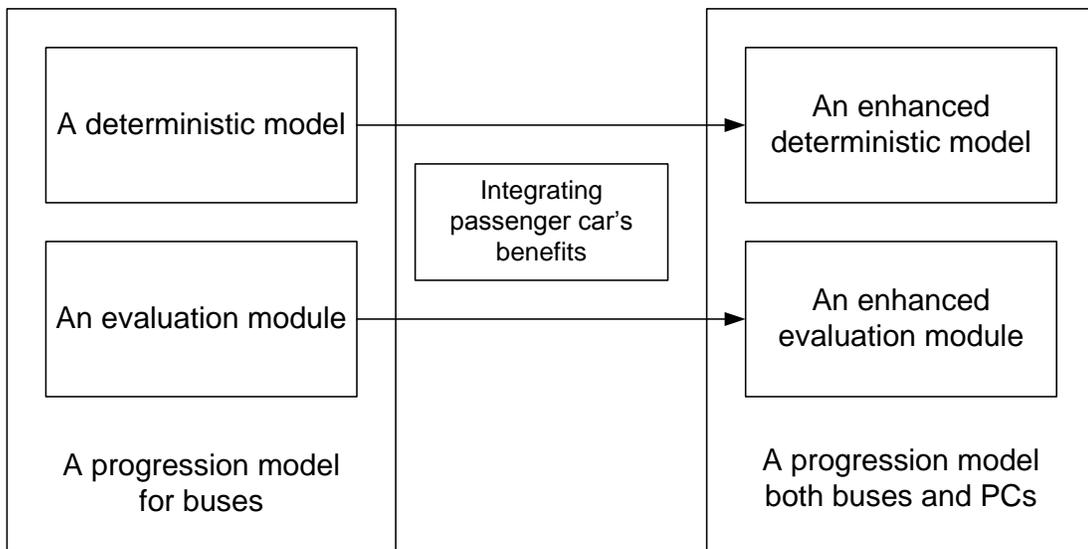

Figure 8. Modelling framework

Chapter 4: Methodology

For convenience of discussion, some key parameters and variables used hereafter are listed in Table 1. Some notations for model formulations are also shown in Figure 5.

Table 1. Model Notations

Variables	Descriptions
I	The set of intersections;
n	Total number of intersections;
$I'(\bar{I}')$	The set of intersections which are at the arriving (departing) of an outbound (inbound) bus stop;
K	The set of bus stops;
$g_i(\bar{g}_i)$	The outbound (inbound) green ratio at intersection i ;
r_i	The time difference from the start of the outbound green to the end of the inbound green at intersection i
$t_i(\bar{t}_i)$	Average outbound (inbound) travel time for buses from intersection i ($i+1$) to intersection $i+1$ (i);
$w_i(\bar{w}_i)$	The time period between the start (end) of a green phase to the center of the bus band at intersection i for the outbound(inbound) direction;
$b_i(\bar{b}_i)$	bus outbound (inbound) bandwidth at intersection i
$t_i^c(\bar{t}_i^c)$	Outbound (inbound) travel time from intersection i ($i+1$) to intersection $i+1$ (i) for passenger cars;

$w_i^c(\bar{w}_i^c)$	The time period between the start (end) of a green to the center of the bus band at intersection i in the outbound(inbound) direction;
$b^c(\bar{b}^c)$	bus outbound (inbound) bandwidth
θ_i	the signal offset at intersection i
$\tau_i(\bar{\tau}_i)$	average dwell time of buses at the outbound (inbound) bus stop after intersection $i(i+1)$
$\sigma_i(\bar{\sigma}_i)$	standard deviation of dwell times for the outbound (inbound) buses at the stop ahead of intersection $i(i+1)$
C	one cycle, and equals 1 in the model
$\varphi_i(\bar{\varphi}_i)$	weighting factor for the outbound (inbound) bandwidth at intersection i
α, β, p	control parameters
$b_i^e(\bar{b}_i^e)$	effective outbound (inbound) bandwidth at intersection i for buses

4.1. Deterministic bus progression model

To accomplish the research objectives, this study has first developed a deterministic bus progression model that takes the preset cycle length, green splits, bus stop capacity, travel time between intersections, and bus dwell times as its major inputs. The proposed model is formulated with Mixed-Integer Linear Programming which optimizes the signal offsets to yield the maximal bus bandwidths. Though this model takes the variance of bus dwell times into account, it is deterministic in nature.

Objective function

The control objective of conventional signal progression models is to maximize the sum of outbound and inbound bandwidths. Since the bus bandwidths for entering and departing from a bus stop need not to be identical, this study will maximize the weighted sum of bandwidths at each intersection. Based on this concept, one can formulate the objective function as follows:

$$\text{Max } \sum_i \varphi_i b_i + \sum_i \bar{\varphi}_i \bar{b}_i \quad (1)$$

The weighting factor should be based on the bus volume at each intersection using the synchronized phase. Let m_i (\bar{m}_i) denote the expected number of outbound (inbound) buses passing intersection i during the synchronized phase in one hour. Then, the weighting factor can be calculated as follows:

$$\varphi_i = \frac{m_i}{\sum_j \frac{m_j}{n}} \quad \forall i \quad (2)$$

$$\bar{\varphi}_i = \frac{\bar{m}_i}{\sum_j \frac{\bar{m}_j}{n}} \quad \forall i \quad (3)$$

Interference constraints

To facilitate the operations model, one shall firstly introduce the following interference constraints:

$$w_i - 0.5b_i \geq 0 \quad w_i + 0.5b_i \leq g_i \quad \forall i \quad (4)$$

$$\bar{w}_i - 0.5\bar{b}_i \geq 0 \quad \bar{w}_i + 0.5\bar{b}_i \leq g_i \quad \forall i \quad (5)$$

Eqs. (4)-(5) can ensure that the green bandwidths don't exceed the available green time.

Progression constraints

This set of constraints are specified to ensure that the signals will not stop the bus flows during the green bands. Each constraint functions to limit the difference between centers of the inbound or outbound bands for each pair of neighboring intersections. Also note that only the average bus dwell times are accounted here.

Taking any pair of neighboring intersections, shown in Figure 5, the progression constraints for the links having bus stops can be expressed as follows:

$$\theta_i + w_i + t_i + \tau_i + n_i C = \theta_{i+1} + w_{i+1} + n_{i+1} C \quad \forall i \in I' \quad (6)$$

$$-\theta_i - r_i + \bar{w}_i + \bar{t}_i + \bar{\tau}_i + \bar{n}_i C = -\theta_{i+1} - r_{i+1} + \bar{w}_{i+1} + \bar{n}_{i+1} C \quad \forall i \in \bar{I}' \quad (7)$$

The progression constraints for the links without bus stops can be shown with similar expressions:

$$\theta_i + w_i + t_i + n_i C = \theta_{i+1} + w_{i+1} + n_{i+1} C \quad \forall i \in I - I' - \{n\} \quad (8)$$

$$-\theta_i - r_i + \bar{w}_i + \bar{t}_i + \bar{n}_i C = -\theta_{i+1} - r_{i+1} + \bar{w}_{i+1} + \bar{n}_{i+1} C \quad \forall i \in I - \bar{I}' - \{n\} \quad (9)$$

Bus stop capacity constraints

Note that on arterials having far-side bus stops, the number of buses dwelling at a stop may exceed the stop capacity and the queue may spill back to the nearby intersections if a serial of buses arrive sequentially over a short interval. Hence, to prevent such queue spillover, one shall set an upper bound to limit the bus bandwidths. Assuming that the bus arriving frequency to each stop follows a Poisson distribution, the probability of k buses to be in the outbound green band i can be expressed as follows:

$$f(k) = \frac{(\lambda b_i)^k \times e^{-\lambda b_i}}{k!} \quad (10)$$

where, λ denotes the bus arrival rate. Then, the upper bound of a bus bandwidth can be computed as follows:

$$b_i^{\max} = \text{arc max}_{b_i} \left\{ \sum_{k=0}^{C_s} \frac{(\lambda b_i)^k \times e^{-\lambda b_i}}{k} \geq p \right\} \quad (11)$$

where, C_s denotes the capacity of the bus stop and p is a parameter to indicate the reliability (e.g., 0.9). Eq. (11) is to ensure a low probability of incurring a spillover.

However, due to the inequality of interference constraints shown in Eqs. (4)-(5), directly adding an upper bound $b_i^{\max}(\bar{b}_i^{\max})$ for $b_i(\bar{b}_i)$ may force the solution

algorithm to simply reduce the value of $b_i(\bar{b}_i)$ without searching the optimal value for the control variables (i.e., offsets). In that case, the bandwidths obtained from the solution may be different from the actual bandwidths.

Therefore, to ensure that the upper bound constraint for the green bandwidth can function effectively, one shall set additional constraints in the outbound direction with a set of new binary variables $x_i(\bar{x}_{i+1})$:

$$w_i - 0.5 \times b_i^{\max} \leq M \times x_i \quad \forall i \in I' \quad (12)$$

$$w_i + 0.5 \times b_i^{\max} \geq g_i - M \times (1 - x_i) \quad \forall i \in I' \quad (13)$$

where, M is a large positive number that dominates all decision variables and parameters. Hence, only one of Eqs. (12)-(13) can be effective in the bus progression model. If x_i equals “1”, Eq. (12) is ineffective and Eq. (13) becomes:

$$w_i + 0.5 \times b_i^{\max} \geq g_i \quad \forall i \in I' \quad (14)$$

Then, Eq. (14) and Eq. (4) will function together to ensure that the length, from the center of bus band to the end of a green phase, is not more than a half of the bandwidth’s upper bound. More specifically, a half of the bus bandwidth will not be larger than a half of its upper bound.

Similarly, if x_k equals “0”, Eq. (13) is ineffective and Eq. (12) becomes:

$$w_i \leq 0.5 \times b_i^{\max} \quad \forall i \in I' \quad (15)$$

Eq. (15) ensures that the length, from the start of a green phase to the center of a bus band, is not more than the half of its upper bound, which can also force the bus bandwidth to be less than its upper bound.

Similarly, for the bus band in the inbound direction, one can derive the following constraints:

$$\bar{w}_{i+1} - 0.5 \times \bar{b}_i^{\max} \leq M \times \bar{x}_{i+1} \quad \forall i \in \bar{I}' \quad (16)$$

$$\bar{w}_{i+1} + 0.5 \times \bar{b}_i^{\max} \geq g_{i+1} - M \times (1 - \bar{x}_{i+1}) \quad \forall i \in \bar{I}' \quad (17)$$

where, \bar{b}_k^{\max} denotes the upper bound of bandwidth of \bar{b}_k , which is calculated with an equation similar to Eq. (11).

Bus dwell time uncertainty

One remaining issue is to account for the impact of bus dwell uncertainties at bus stops on the progression design. As discussed previously, taking bus stops as the control points, the bandwidth for buses to enter the stops may differ from the one for departure. Hence, some constraints are needed to ensure that the band at the downstream of a bus stop can accommodate the number of buses coming from the arriving band. As shown in Figure 9, to keep vehicles (within band ab_i) entering from the arriving green band to stay within the departing green band b_{i+1} if the dwell time uncertainty is within ε , the following constraints shall be satisfied:

$$(\mu + \varepsilon) > \frac{1}{2}\alpha b_i + \mu - \frac{1}{2}b_{i+1} \quad (18)$$

$$(\mu + \varepsilon) < \frac{1}{2}\alpha b_i + \mu + \frac{1}{2}b_{i+1} \quad (19)$$

$$\alpha b_i + (\mu + \varepsilon) > \frac{1}{2}\alpha b_i + \mu - \frac{1}{2}b_{i+1} \quad (20)$$

$$\alpha b_i + (\mu + \varepsilon) < \frac{1}{2}\alpha b_i + \mu + \frac{1}{2}b_{i+1} \quad (21)$$

where, μ denotes the mean bus dwell time and ε denotes its uncertainty; α is a conservative parameter which represents the portion of effective bandwidth for the arriving bus band. Also, Eq. (18-19) and (20-21) are specified to ensure that the first and last buses within the arriving band (αb_i) can catch the departing band after dwelling at the bus stop.

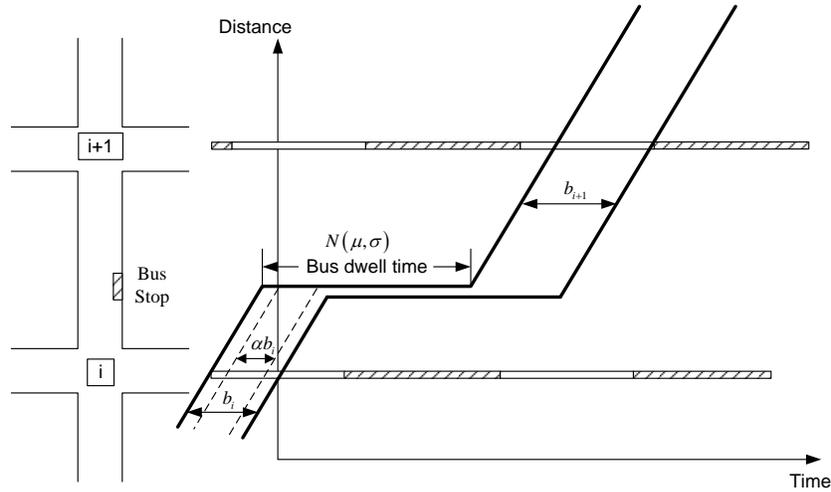

Figure 9. Impact of bus dwell time uncertainties

By integrating these four constraints, one can reach the following relations:

$$b_{i+1} \geq \alpha b_i + |2\varepsilon| \quad (22)$$

In Eq. (22), $|2\varepsilon|$ represents the tolerance of the dwell time uncertainty. It should be a function of the standard deviation of the dwell time. By defining $\rho\sigma=|2\varepsilon|$, one can get the following constraints:

$$\bar{b}_{i+1} \geq \alpha \cdot \bar{b}_i + \beta \cdot \sigma_i \quad \forall i \in I' \quad (23)$$

where, β is a control parameter which indicates the preferred confidence level.

Similarly, for the inbound direction, the constraints should be:

$$\bar{b}_i \geq \alpha \cdot \bar{b}_{i+1} + \beta \cdot \bar{\sigma}_i \quad \forall i \in \bar{I}' \quad (24)$$

For other pairs of intersections, the bandwidths should be identical since the travel time on this link is assumed to be deterministic.

$$b_i = b_{i+1} \quad \forall i \in I - I' \quad (25)$$

$$\bar{b}_i = \bar{b}_{i+1} \quad \forall i \in I - \bar{I}' \quad (26)$$

In brief, the optimization model could be summarized as follows:

$$\text{Max} \sum_i \varphi_i b_i + \sum_i \bar{\varphi}_i \bar{b}_i \cdot$$

s.t.

$$w_i - 0.5b_i \geq 0 \quad w_i + 0.5b_i \leq g_i \quad \forall i$$

$$\bar{w}_i - 0.5\bar{b}_i \geq 0 \quad \bar{w}_i + 0.5\bar{b}_i \leq g_i \quad \forall i$$

$$\theta_i + w_i + t_i + \tau_i + n_i C = \theta_{i+1} + w_{i+1} + n_{i+1} C \quad \forall i \in I'$$

$$\begin{aligned}
-\theta_i - r_i + \bar{w}_i + \bar{t}_i + \bar{\tau}_i + \bar{n}_i C &= -\theta_{i+1} - r_{i+1} + \bar{w}_{i+1} + \bar{n}_{i+1} C & \forall i \in \bar{I}' \\
\theta_i + w_i + t_i + n_i C &= \theta_{i+1} + w_{i+1} + n_{i+1} C & \forall i \in I - I' - \{n\} \\
-\theta_i - r_i + \bar{w}_i + \bar{t}_i + \bar{n}_i C &= -\theta_{i+1} - r_{i+1} + \bar{w}_{i+1} + \bar{n}_{i+1} C & \forall i \in I - \bar{I}' - \{n\} \\
w_i - 0.5 \times b_i^{\max} &\leq M \times x_i & \forall i \in I' \\
w_i + 0.5 \times b_i^{\max} &\geq g_i - M \times (1 - x_i) & \forall i \in I' \\
\bar{w}_{i+1} - 0.5 \times \bar{b}_i^{\max} &\leq M \times \bar{x}_{i+1} & \forall i \in \bar{I}' \\
\bar{w}_{i+1} + 0.5 \times \bar{b}_i^{\max} &\geq g_{i+1} - M \times (1 - \bar{x}_{i+1}) & \forall i \in \bar{I}' \\
b_{i+1} &\geq \alpha \cdot b_i + \beta \cdot \sigma_i & \forall i \in I' \\
\bar{b}_i &\geq \alpha \cdot \bar{b}_{i+1} + \beta \cdot \bar{\sigma}_i & \forall i \in \bar{I}' \\
b_i &= b_{i+1} & \forall i \in I - I' \\
\bar{b}_i &= \bar{b}_{i+1} & \forall i \in I - \bar{I}' \\
b_i, w_i, \bar{b}_i, \bar{w}_i &\geq 0 \\
n_i, \bar{n}_i &\text{ are integer variables} \\
x_i, \bar{x}_i &\text{ are binary variables}
\end{aligned}$$

Note that the proposed model is formulated with the mixed-integer-linear-programming, which can be solved with existing algorithms due to its limited number of decision variables.

4.2. Evaluation module

Notably, different parameters in Eq. (23) and (24) may yield different optimal solutions and objective values. Due to the stochastic nature of bus dwell time,

the operational performance of one solution is determined not only by the absolute objective value, but also by the relations between each pair of neighboring bandwidths. This can be observed from the example shown in Figure 10, where, the large arriving band would receive more buses, but only a small proportion of these buses can be expected to stay in the band toward the downstream intersection. In contrast, a smaller arriving band, as shown in Figure 10(b), may receive fewer buses, but can allow a larger percentage of those buses to depart from the bus stop within its departing band. Although these two plans may yield the same objective values, the actual performance can be quite different. The effectiveness of a signal progression plan depends highly on the relation and width between the arriving and departing bands at a bus stop.

Therefore, these solutions are called sub-optimal solutions and the optimal solution cannot be identified based solely on their objective values.

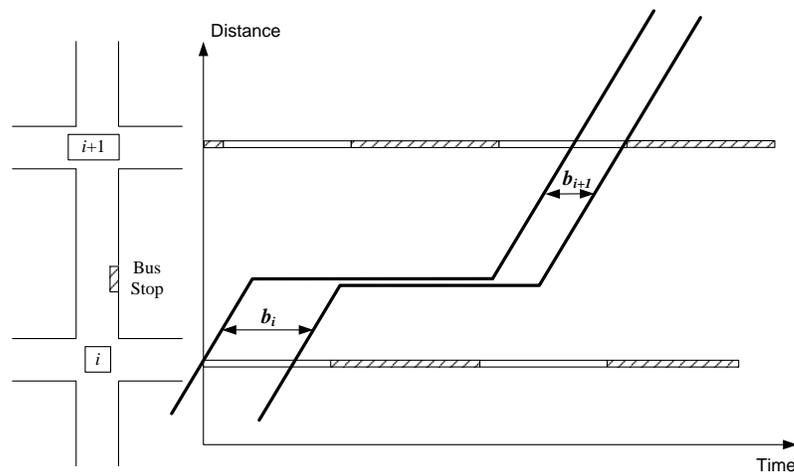

(a) A large arriving band and a small departing band

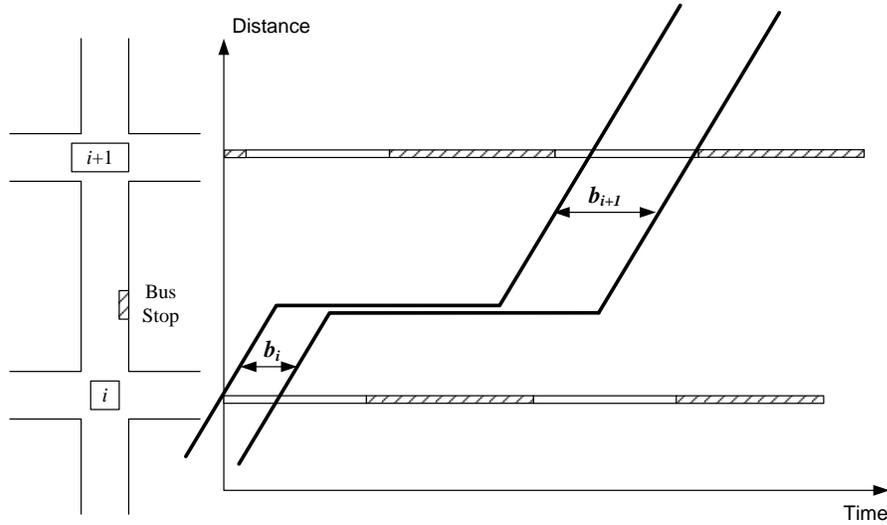

(b) A small arriving band and a large departing band

Figure 10. Graphical illustration of relation between progression bands at two neighboring intersections

To identify the optimal results among all sub-optimal solutions, this study has proposed a stochastic method to evaluate the solutions with different parameters in Eq. (23) and (24). For each sub-optimal solution, a ranking index, which is the total *effective bandwidth*, will be calculated to evaluate its performance in practice. However, the formula to calculate the ranking index is not linear due to the stochastic nature of bus dwell time. Hence, this process cannot be integrated into the linear programming model. A supplemental module of the deterministic model to account for the bus dwell time uncertainty is presented below.

Enhancement to the deterministic model

When applying Eq. (23) and (24), it is noticeable that the computational complexity increases exponentially with the number of parameters, because one

needs to solve the linear programming formulations for each pair of parameter values.

Therefore, Eq. (23) and (24) have been revised as follows:

$$b_{i+1} \geq \alpha' \cdot b_i \quad \forall i \in I' \quad (27)$$

$$\bar{b}_i \geq \alpha' \cdot \bar{b}_{i+1} \quad \forall i \in \bar{I}' \quad (28)$$

Such an enhancement does not sacrifice these two constraints, because 1) they can still ensure a relatively large departing bandwidth based on its arriving bandwidth; and 2) although the dwell time variance is no longer considered in these constraints, the analysis to sub-optimal solutions applies a more rigorous method to assess the impact of dwell time on the progression band.

Notably, different values for parameter, α' , may yield different solutions. A larger α' will ensure a higher percentage of buses to stay within the band after dwelling at the stop. In contrast, a smaller α' allows a larger arriving bandwidth, which will grant more buses for progression.

The range and intervals for parameter α'

To find the upper bound and lower bound for α' , one needs to determine a minimal and a maximal bandwidths. The minimal bandwidth, b_{min} , is set to the value that any smaller band will be meaningless operationally. The maximum bandwidth, b_{max} , is set to the level that any larger band would not result in a feasible solution.

Let $b_{max,i}$ denote the maximal bandwidth at intersection i ., and the upper bound of parameter α can be expressed as follows:

$$\alpha^u = \min_k \left(\sqrt[k-1]{\frac{b_{max,k}}{b_{min}}}, \sqrt[n-k]{\frac{b_{max,k}}{b_{min}}} \right) \quad (29)$$

Any α' larger than α^u will result in an excessive bandwidth at the most distant downstream intersection, even if the most distant arriving bandwidth equals b_{min} . More specifically, the lower bound can be expressed as:

$$\alpha^l = \min_k \left(\frac{b_{min}}{b_{max,k}} \right) \quad (30)$$

Any α' smaller than α^l allows a departing band smaller than b_{min} , even if the arriving bandwidth equals to the maximal bandwidth.

To avoid redundant sub-optimal solutions, the interval of α between two adjacent values applied to the model is expressed by:

$$\alpha^{min} = \max_k \left(\frac{1}{b_{max,k} \times cycle\ length} \right) \quad (31)$$

This is based on an assumption that the resolution of the bandwidth is one second. An interval smaller than α^{min} may result in very similar sub-optimal solutions, which produce similar offsets for each intersection. Therefore, the number of different values for α to be applied in the model is

$$\frac{\alpha^u - \alpha^l}{\alpha^{\min}} \quad (32)$$

Effective bandwidth

The effectiveness of a signal plan highly depends on the relation between each pair of bands arriving to and departing from a bus stop. To evaluate the sub-optimal solutions, the evaluation module is used to compute the estimated fraction of the arriving bandwidth which can be effectively utilized. The expectation of this estimated fraction is called effective bandwidth. It is a critical index for use to evaluate each sub-optimal solution. The effective bandwidth indicates the number of buses which may stay in the band between these two intersections. Therefore, if no bus stop is located between intersection i and $i+1$, the effective outbound bandwidth for intersection $i(i+1)$ is defined as follows.

$$b_i^e = b_i \quad \forall i \in I - I' \quad (33)$$

$$\bar{b}_{i+1}^e = \bar{b}_{i+1} \quad \forall i \in I - \bar{I}' \quad (34)$$

If a bus stop is located between intersection i and $i+1$, the effective outbound bandwidth for intersection i is calculated as follows. To evaluate these signal plans from a stochastic perspective, one needs to first calculate the probability that an arriving bus can stay within the departing band after leaving the bus stop. Figure 11 shows an example of bus bands at two adjacent intersections, where the dash line indicates that the center of green bands and the solid line represents the trajectory of one bus moving in the outbound direction; x_i denotes the time when a bus passes

intersection k , measured by its difference from the center of the band. Then, the expected arrival time of the bus at intersection $i+1$ is denoted by x_{i+1} , which equals x_i , because the travel time plus the expected dwell time is just the horizontal difference between the centers of these bands.

For simplicity but without loss of generality, this study assumes that the dwell time follows a normal distribution with a standard deviation of σ_i , then the actual arrival time to the downstream intersection follows a distribution with a mean of x_i and a standard deviation of σ_i . The probability that the arriving bus can stay in the departing band is the probability that the actual arrival time to the downstream intersection is within the departing band. The actual arrival time can also be measured with its difference from the center of the band, as shown in Figure 11. Therefore, the probability can be expressed as follows:

$$\begin{aligned}
 P(-0.5b_{i+1} \leq x_{i+1} \leq 0.5b_{i+1}) &= \Phi\left(\frac{0.5b_{i+1} - x_{i+1}}{\sigma_i}\right) - \Phi\left(\frac{-0.5b_{i+1} - x_{i+1}}{\sigma_i}\right) \\
 &= \Phi\left(\frac{0.5b_{i+1} - x_i}{\sigma_i}\right) - \Phi\left(\frac{-0.5b_{i+1} - x_i}{\sigma_i}\right)
 \end{aligned} \tag{35}$$

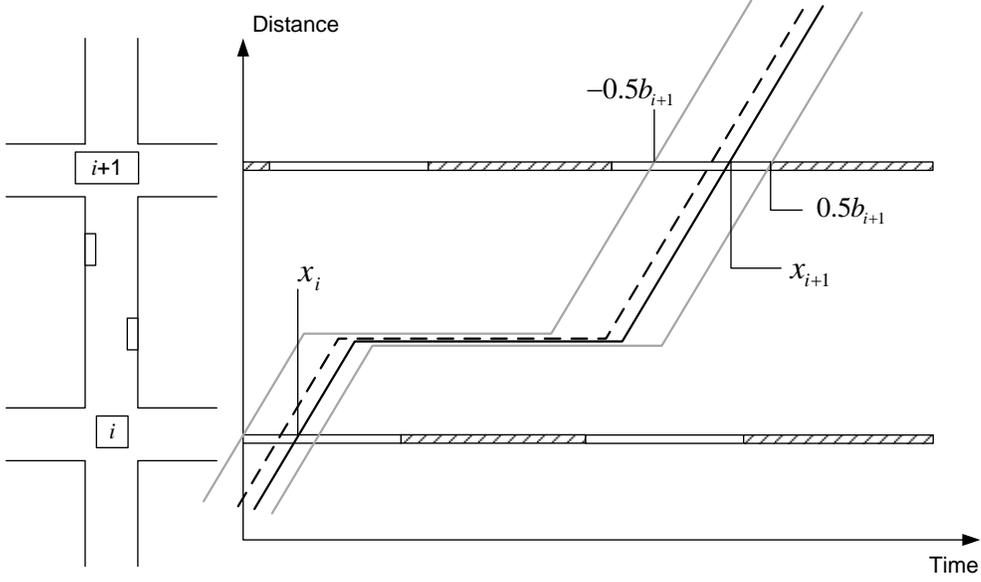

Figure 11. Stochastic Analysis for Two Adjacent Intersections

Note that the value of x_i shall lie between $-0.5b_i$ and $0.5b_i$. By integrating the probability with x_i to get the effective bandwidth at intersection i , one can have the following expression:

$$b_i^e = \int_{-0.5b_i}^{0.5b_i} \Phi\left(\frac{0.5b_{i+1} - x_i}{\sigma_i}\right) - \Phi\left(\frac{-0.5b_{i+1} - x_i}{\sigma_i}\right) dx_i \quad (36)$$

where, b_k^e denotes the effective bandwidth at intersection k . By the same token, the calculation for an inbound effective bandwidth can be expressed as:

$$\bar{b}_{i+1}^e = \int_{-0.5\bar{b}_{i+1}}^{0.5\bar{b}_{i+1}} \Phi\left(\frac{0.5\bar{b}_i - \bar{x}_{i+1}}{\bar{\sigma}_i}\right) - \Phi\left(\frac{-0.5\bar{b}_i - \bar{x}_{i+1}}{\bar{\sigma}_i}\right) d\bar{x}_{i+1} \quad (37)$$

In summary, for those links without bus stops, the effective bandwidth can be directly obtained with Eqs. (33)-(34). In contrast, for the other links with bus stops,

one shall account for the impact caused by bus dwell time uncertainty and implement Eqs. (36)-(37) to estimate the effective bandwidth.

Based on the definitions given above, it should be noted that a larger effective bandwidth can guarantee a higher proportion of transit vehicles to receive the progression. Hence, the total effective bandwidths can serve as an indicator to evaluate the effectiveness of the bus progression system.

In brief, a step-by-step description of the process that integrates the stochastic analysis with the deterministic model to yield the optimal bus progression band is presented in Figure 12. The deterministic model and the evaluation module work together to constitute a complete model for bus progression design.

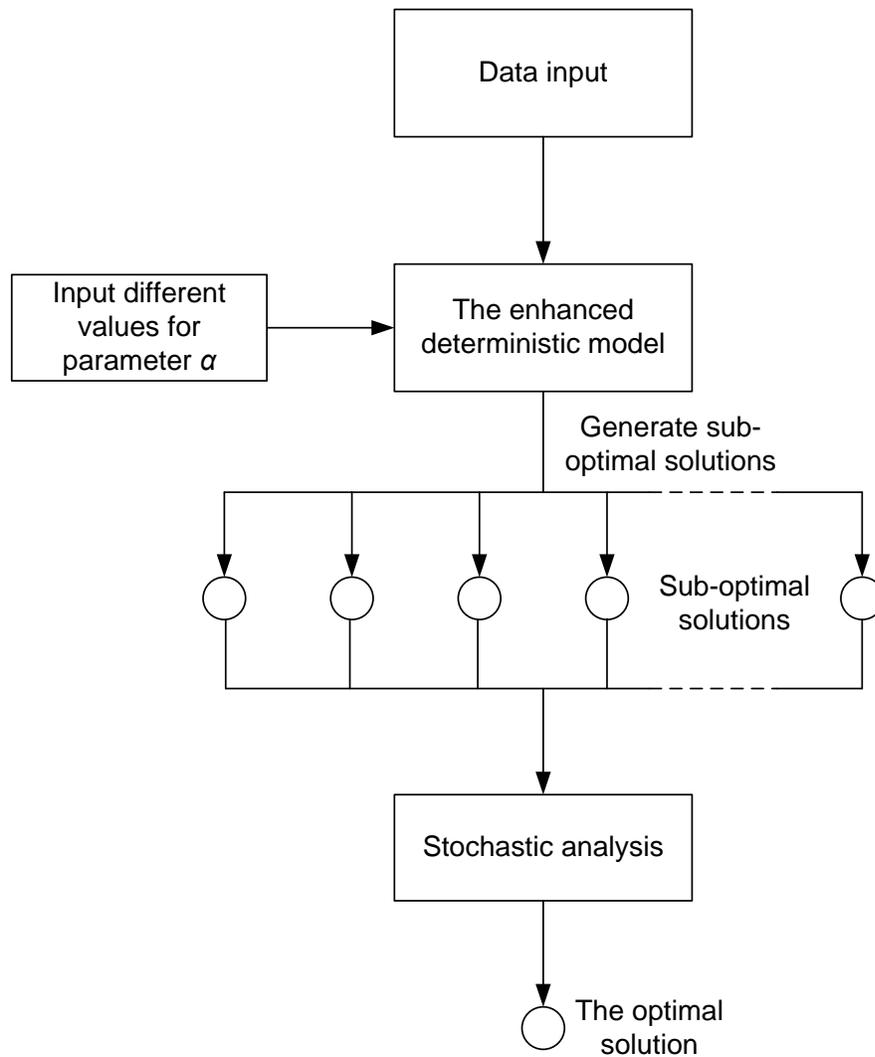

Figure 12. Flowchart for using the deterministic model with stochastic analysis to identify the optimal bus-progression solution

By using the stochastic analysis method, one can find an optimal phase plan that allows buses to progress smoothly over the target arterial. However, this proposed method considers only buses, and may not grant the same level of progression to passenger cars.

4.3. Integrated model

Note that the bus bands obtained from the above model may not benefit the passenger cars, and often cause potential interruption to passenger cars. Thus, a model to concurrently optimize the bus band and passenger car band is desirable. To achieve this objective, this study has further enhanced the deterministic model and the evaluation module by integrating the operational characteristics of passenger cars.

Enhancement to the deterministic model

Since the objective of the integrated model is set to minimize the total personal delay from those in transit vehicles and passenger cars, some new variables and constraints specified below need to be introduced to the deterministic model :

$$w_i^c - 0.5b^c \geq 0 \quad w_i^c + 0.5b^c \leq g_i \quad \forall i \in I \quad (38)$$

$$\bar{w}_i^c - 0.5\bar{b}^c \geq 0 \quad \bar{w}_i^c + 0.5\bar{b}^c \leq g_i \quad \forall i \in I \quad (39)$$

$$\theta_i + w_i^c + t_i^c + n_i^c C = \theta_{i+1} + w_{i+1}^c + n_{i+1}^c C \quad \forall i \in I - \{n\} \quad (40)$$

$$-\theta_i - r_i + \bar{w}_i^c + \bar{t}_i^c + \bar{n}_i^c C = -\theta_{i+1} - r_{i+1} + \bar{w}_{i+1}^c + \bar{n}_{i+1}^c C \quad \forall i \in I - \{n\} \quad (41)$$

where, b^c (\bar{b}^c) denotes the outbound (inbound) passenger car bandwidth. Note that this bandwidth does not vary between intersections since the travel time between intersections is assumed to be deterministic. Similar to the variables for bus bands, w_i^c (\bar{w}_i^c) denotes the time period between the start (end) of a green phase and the

center of the outbound band toward intersection i . And $t_i^c(\bar{t}_i^c)$ denotes the outbound (inbound) travel time from intersection i ($i+1$) to intersection $i+1$ (i). Note that the travel times for passenger cars and buses can be different and vary with traffic conditions. With constraints (38)-(41), the passenger car bands can be expressed properly.

As mentioned previously, the objective of the revised deterministic model should be to maximize the weighted sum of these two types of bands. The weighting factor should correspond to the numbers of passengers on these two types of vehicles.

Let k denote the ratio between the numbers of passengers on buses and on passenger cars. Then, k can be expressed as follows:

$$k = \frac{\rho^b \sum_j m_j}{\rho^c \sum_j m_j^c} \quad (42)$$

where, ρ^b and ρ^c denote the loading factor for buses and passenger cars, respectively.

Similar to m_i , m_i^c denote the expected number of outbound (inbound) passenger cars passing intersection i during the synchronized phase in one hour. Then, the objective should be expressed as

$$Max \quad k \left(\sum_i \varphi_i b_i + \sum_i \bar{\varphi}_i \bar{b}_i \right) + n \left(b^c + \bar{b}^c \right) \quad (43)$$

Note that in design of signal progression for congested arterials one shall not make the bandwidth of one type of vehicles to dominate the others. Hence, a set of ratio constraints is proposed to balance the bus bands and the passenger-car bands,

$$(1-k)\left(\sum_i \varphi_i b_i + \sum_i \bar{\varphi}_i \bar{b}_i\right) \geq k(1-k)n(b^c + \bar{b}^c) \quad (44)$$

With constraint (44), the benefits of vehicles with less passengers will not be sacrificed when searching for the optimal solution.

In brief, the integrated deterministic model can be summarized as below:

$$\text{Max } k\left(\sum_i \varphi_i b_i + \sum_i \bar{\varphi}_i \bar{b}_i\right) + n(b^c + \bar{b}^c)$$

s.t.

$$w_i - 0.5b_i \geq 0 \quad w_i + 0.5b_i \leq g_i \quad \forall i$$

$$\bar{w}_i - 0.5\bar{b}_i \geq 0 \quad \bar{w}_i + 0.5\bar{b}_i \leq g_i \quad \forall i$$

$$\theta_i + w_i + t_i + \tau_i + n_i C = \theta_{i+1} + w_{i+1} + n_{i+1} C \quad \forall i \in I'$$

$$-\theta_i - r_i + \bar{w}_i + \bar{t}_i + \bar{\tau}_i + \bar{n}_i C = -\theta_{i+1} - r_{i+1} + \bar{w}_{i+1} + \bar{n}_{i+1} C \quad \forall i \in \bar{I}'$$

$$\theta_i + w_i + t_i + n_i C = \theta_{i+1} + w_{i+1} + n_{i+1} C \quad \forall i \in I - I' - \{n\}$$

$$-\theta_i - r_i + \bar{w}_i + \bar{t}_i + \bar{n}_i C = -\theta_{i+1} - r_{i+1} + \bar{w}_{i+1} + \bar{n}_{i+1} C \quad \forall i \in I - \bar{I}' - \{n\}$$

$$w_i - 0.5 \times b_i^{\max} \leq M \times x_i \quad \forall i \in I'$$

$$w_i + 0.5 \times b_i^{\max} \geq g_i - M \times (1 - x_i) \quad \forall i \in I'$$

$$\bar{w}_{i+1} - 0.5 \times \bar{b}_i^{\max} \leq M \times \bar{x}_{i+1} \quad \forall i \in \bar{I}'$$

$$\bar{w}_{i+1} + 0.5 \times \bar{b}_i^{\max} \geq g_{i+1} - M \times (1 - \bar{x}_{i+1}) \quad \forall i \in \bar{I}'$$

$$b_{i+1} \geq \alpha \cdot b_i \quad \forall i \in I'$$

$$\bar{b}_i \geq \alpha \cdot \bar{b}_{i+1} \quad \forall i \in \bar{I}'$$

$$b_i = b_{i+1} \quad \forall i \in I - I'$$

$$\bar{b}_i = \bar{b}_{i+1} \quad \forall i \in I - \bar{I}'$$

$$w_i^c - 0.5b^c \geq 0 \quad w_i^c + 0.5b^c \leq g_i \quad \forall i \in I$$

$$\bar{w}_i^c - 0.5\bar{b}^c \geq 0 \quad \bar{w}_i^c + 0.5\bar{b}^c \leq g_i \quad \forall i \in I$$

$$\theta_i + w_i^c + t_i^c + n_i^c C = \theta_{i+1} + w_{i+1}^c + n_{i+1}^c C \quad \forall i \in I - \{n\}$$

$$-\theta_i - r_i + \bar{w}_i^c + \bar{t}_i^c + \bar{n}_i^c C = -\theta_{i+1} - r_{i+1} + \bar{w}_{i+1}^c + \bar{n}_{i+1}^c C \quad \forall i \in I - \{n\}$$

$$(1-k) \left(\sum_i \varphi_i b_i + \sum_i \bar{\varphi}_i \bar{b}_i \right) \geq k(1-k)n(b^c + \bar{b}^c)$$

$$b_i, w_i, \bar{b}_i, \bar{w}_i, b^c, w_i^c, \bar{b}^c, \bar{w}_i^c \geq 0$$

n_i, \bar{n}_i are integer variables

x_i, \bar{x}_i are binary variables

Enhancement to the evaluation module

In the integrated model, the ranking index should include effective bandwidths for both bus bands and passenger-car bands. The effective bandwidths for bus bands can be calculated with the same method as introduced previously, while the effective bandwidths for passenger car bands should be equal to the bandwidths given by the MILP solution, because the travel time between intersections is assumed to be

deterministic. By the same token, the ranking index for the integrated model can be calculated with the following equation:

$$R = k \left(\sum_{i=1}^{n-1} b_i^e + \sum_{i=2}^n \bar{b}_i^e \right) + (n-1)(b^c + \bar{b}^c) \quad (45)$$

The coefficient for the sum of passenger car bands is $n-1$ since the effective bandwidth at the most downstream intersection is not included in computing for the bus band.

With the integrated ranking index, the computing process for the proposed integrated model is shown in Figure 13.

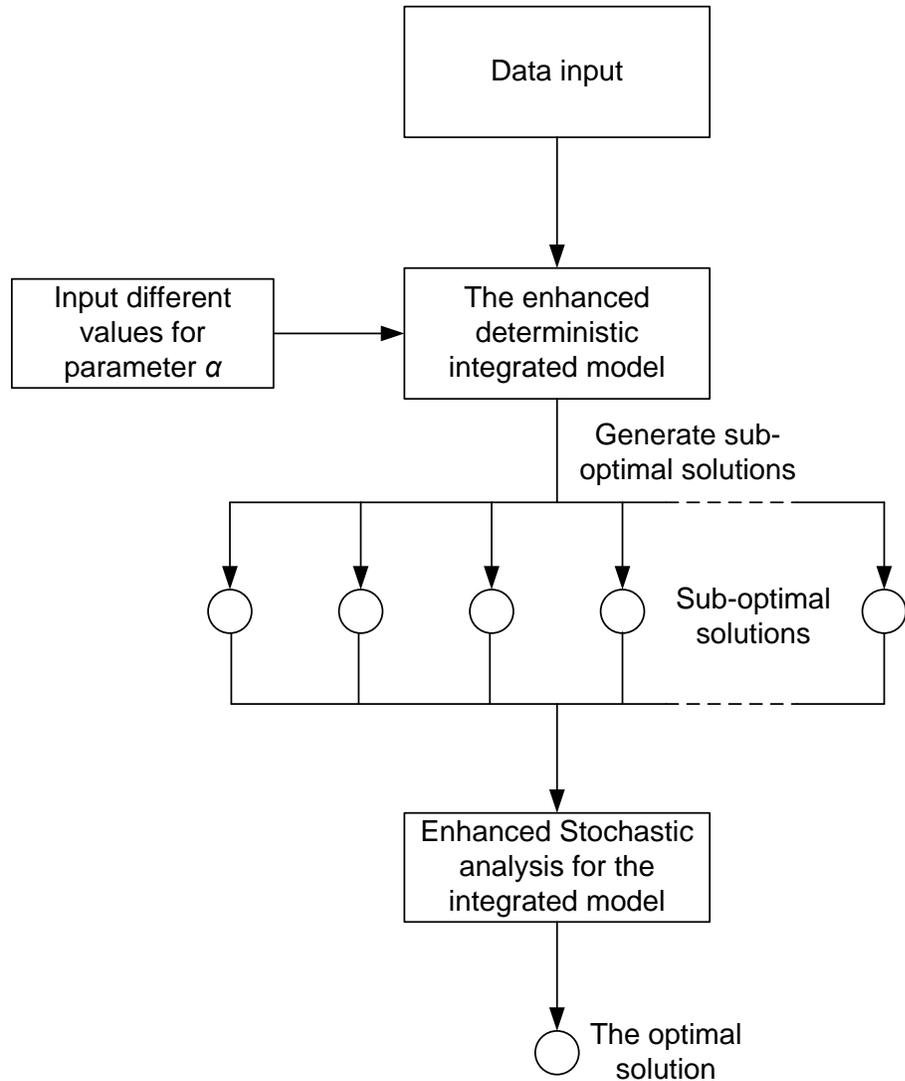

Figure 13. Flow chart of the integrated model

4.4. Summary

In summary, this chapter has introduced methodology for optimizing the bus-based progression offsets. Firstly, a deterministic model that considers the dwell time of buses and the capacity of bus stops is developed. Secondly, an evaluation stage is developed to focus on assessing the impact of stochastic nature of bus dwell

time on identification of the optimal solution. Then, an integrated model developed to optimize the bandwidths for both buses and passenger cars using the core logic from the first two models but with additional enhancement to reflect the personal benefit in search for the optimal signal progression design.

Chapter 5: Case Study

This chapter presents experimental analysis results, focusing on evaluating the performance of the proposed models under various traffic conditions. Extensive sensitivity analysis conducted to evaluate the stability of the proposed models with respect to key parameters is reported in the chapter.

5.1. *Case design*

Target Site for case study

An arterial segment on Liufang Ave. North in Beijing has been taken as the study site. As shown in Figure 14, the experimental system for performance evaluation consists of five intersections, four connecting links, and three two-way bus stops.

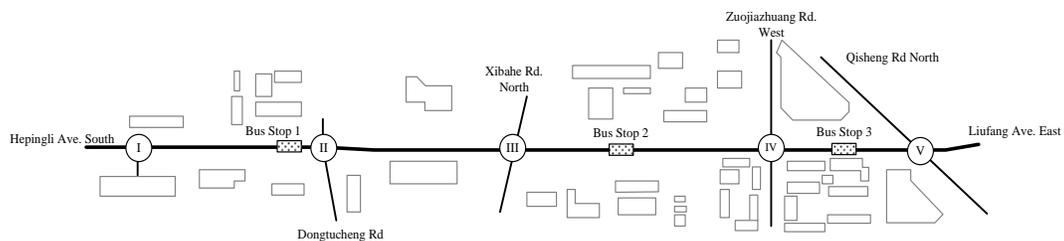

Figure 14. Illustration of the target arterial for experimental analysis

The key traffic patterns, geometric features, and primary parameters used in the analysis are listed below:

- The common cycle length of the five intersection is set to be 150 seconds;

- The outbound and inbound bus flows share the same signal phase and their green times at intersections are 99 , 77 , 66, 51, and 60 seconds, respectively;
- From intersection I to intersection V, the bus travel time between neighboring intersections are 20, 21, 28, 16 seconds, respectively;
- The dwell time at all three bus stops are assumed to follow the normal distributions, which are: bus stop 1: $N(30,9)$; bus stop 2: $N(27,7)$; bus stop 3: $(24,9)$;
- The bus volume is 60 veh/h, with an average headway of one minute and the passenger car volume is 720 veh/h;
- The bus stop capacity is 2 buses, and the confidence parameter, p , equals 0.95; then the maximal bus bandwidth could be computed as 50 seconds using Eq. (11);
- The minimal bandwidth is set to be 5 seconds, and the bandwidth resolution is one second.
- The loading factors for buses and passenger cars are set to be 18 and 1.2 persons, respectively.

The models to be evaluated with the simulation experiments are listed below:

- Model-1: MAXBAND with a prespecified phase sequence
- Model-2: A direct extension of MAXBAND by adding the average bus dwell time onto the travel time on the links having a bus stop.

- Model-3: The proposed deterministic model
- Model-4: The proposed deterministic model with stochastic ranking analysis module
- Model-5: The proposed integrated model

Bandwidths and performance measures generated by Models-2, 3 and 4 will first be compared to verify the need of further proceeding the stochastic analysis. Then, the signal plans generated by Models-1, 2, 4 and 5 are programmed in the simulation software, VISSIM, and evaluated based on the average delays and number of stops. Sensitivity Analysis with respect to the number of passengers on buses is also conducted to assess the stability of the proposed models.

VISSIM simulation designs

To illustrate the applicability and efficiency of the proposed models, this study has employed VISSIM as an unbiased simulation tool for performance evaluation.

In the simulation, the inter-arrival time of buses entering the experimental network is set to be deterministic. To address this issue, a dummy stop is set at the upstream of the first intersection for each direction. The variance of dwell times at this stop is set to be relative large to replicate the stochastic nature of bus arriving patterns. The parameters in VISSIM adopted for experimental analyses are listed in Table 2:

Table 2. Adjusted VISSIM parameters

Parameters	Value
Average stand still distance (Urban)	6.56 ft
Maximum deceleration (Lane Change)	-13.12 ft/s ²
Accepted deceleration (Lane Change)	-3.28 ft/s ²
Maximum deceleration for cooperative braking	-9.84 ft/s ²

5.2. Model Evaluation

Bus progression models

Evaluation of the proposed bus progression models starts with the comparison of different bandwidths generated by the models. The values of parameters α and β are set to be 0.3 and 1, respectively, in Model -3. The resulting signal plans of Models-2, 3 and 4 are shown in Table 3, and the corresponding bands are shown in Figure 15. Notably, Model-1 cannot generate a non-zero bus band since it does not include all essential constraints. Therefore, it is not listed for comparison in Figure 15.

Table 3. Offsets (seconds) calculated with Models-2,3 and 4

	intersection No.				
	1	2	3	4	5
Model-2	0	50	40	0	141
Model-3	0	102	101	40	38
Model-4	0	99	104	39	35

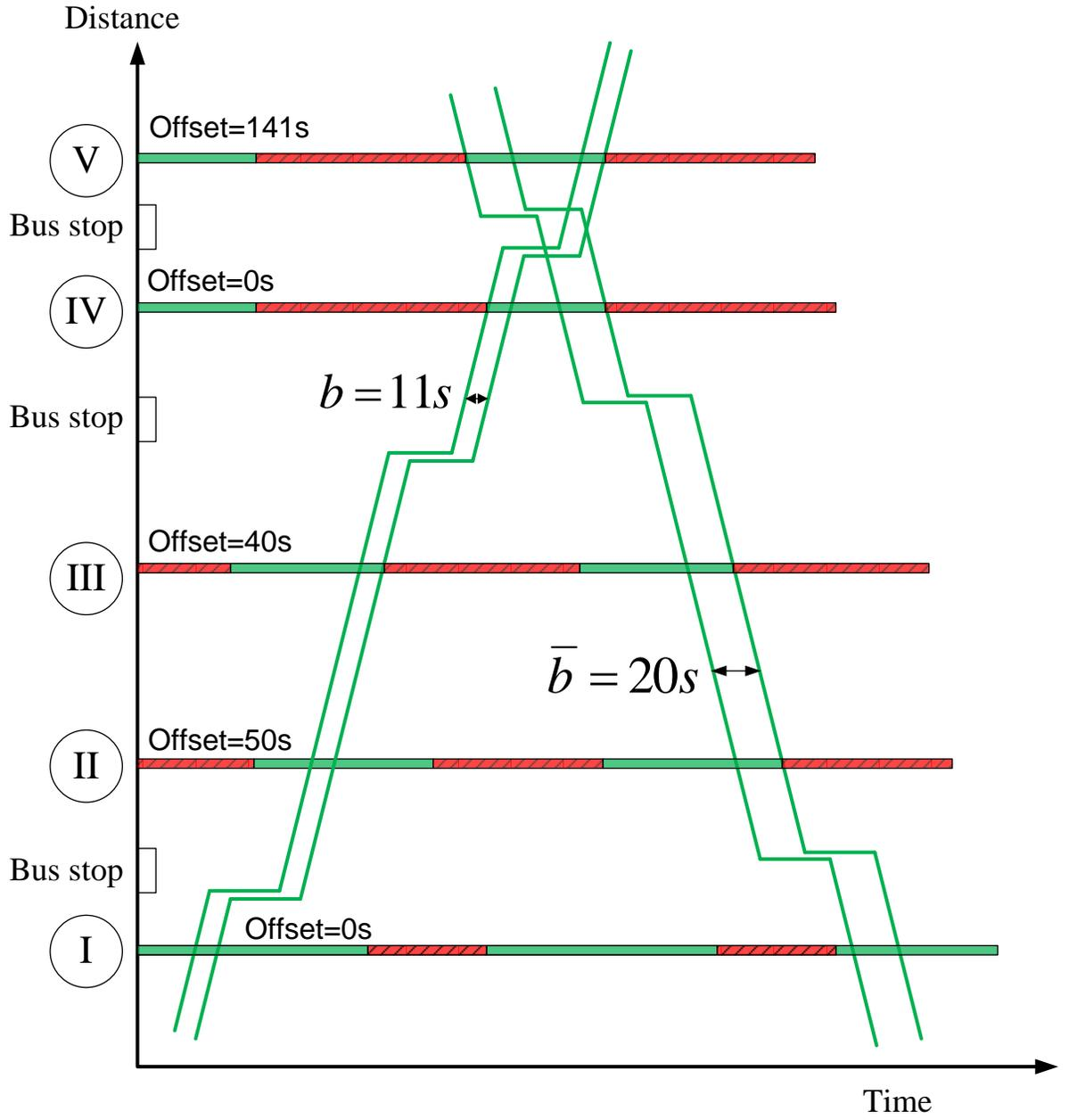

Figure 15 (A) Model-2

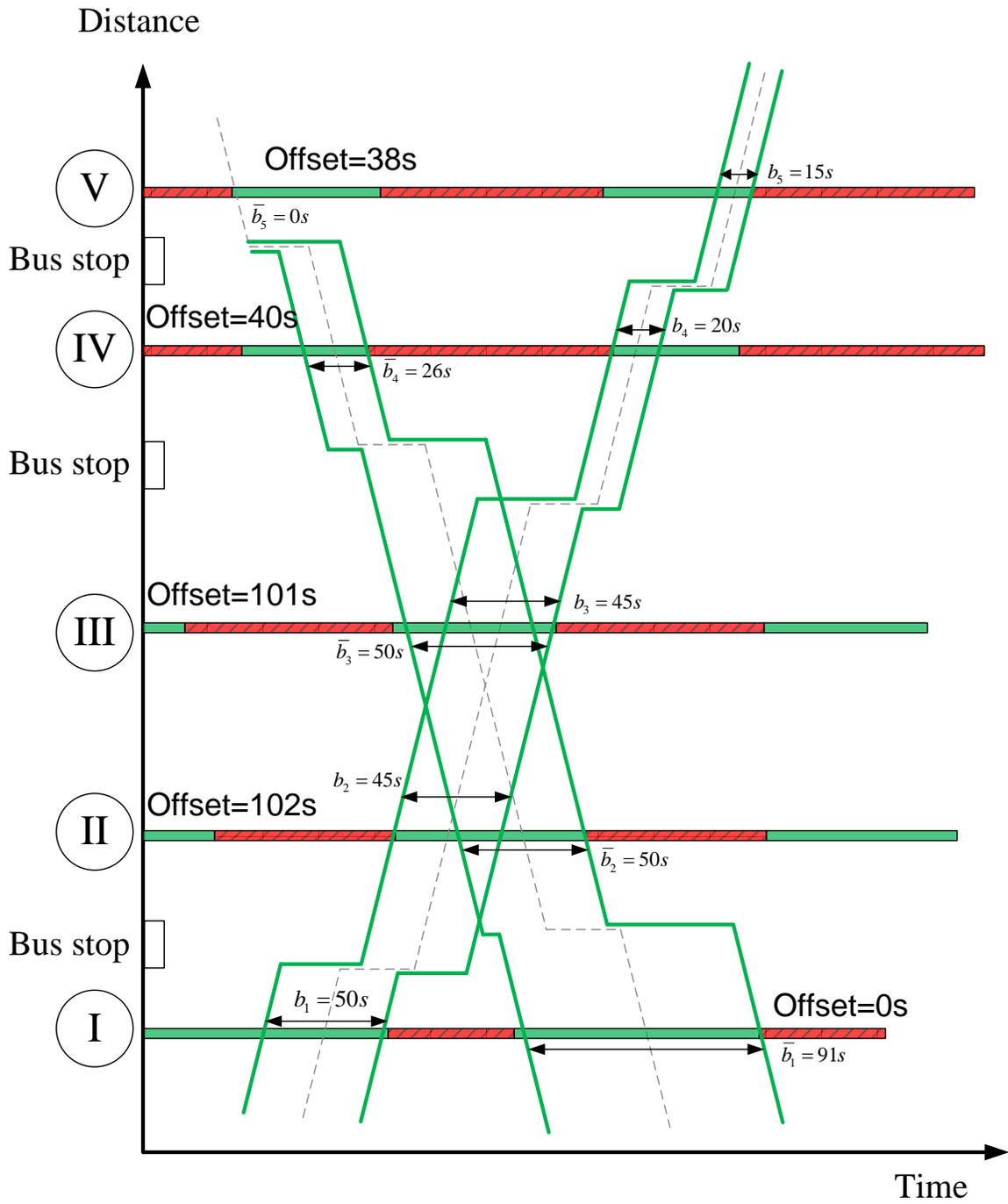

Figure 15 (B) Model-3

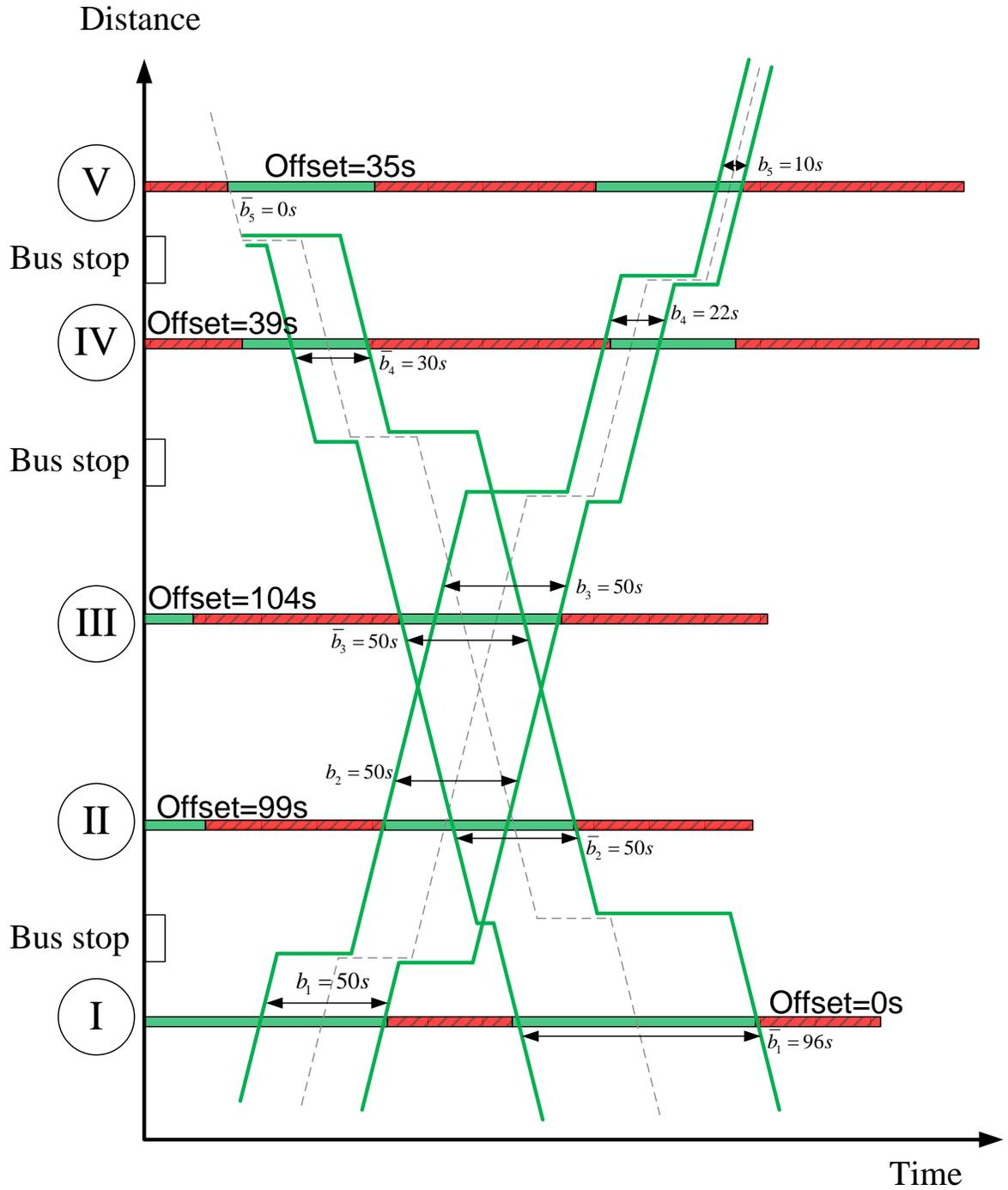

Figure 15 (C) Model-4

Figure 15. Progression bands generated by different models

From Figure 15(A), one can observe that the bus bands in both the outbound and inbound directions remain unchanged over these five intersections. At each intersection, the green band is shifted to the right side for a short interval, which represents the impact caused by the average bus dwell time.

Taking each bus stop as a control point to change the bandwidths, Model-3 and Model-4 generate a set of variable bus bands. Though the bus bands have been reduced to zero at some intersections due to the limitation of green time, some buses may still be benefited by the progression band if the actual dwell time is different from the average dwell time. Based on the comparisons, one can observe that the proposed bus band model can clearly outperform Model-2 in terms of providing effective bands for bus flows.

To further verify the necessity of exercising the stochastic evaluation, five sets of parameters of α and β are applied to Model-3. These parameters and optimization results are listed in Table 4. These signal plans are also applied along with that generated by Model-4 in the VISSIM network. The simulation results are listed in Figure 16, which adopts the average bus delays and number of stops as the performance measures.

Table 4. Optimization results of Model-3 with different sets of parameters

			Offsets (s) at Intersection No.				
	α	β	1	2	3	4	5
Model-3-1	0.3	1	0	102	101	40	38
Model-3-2	0.3	2	0	107	104	38	43
Model-3-3	0.5	1	0	105	98	37	41

Model-3-4	0	1	0	99	104	25	35
Model-3-5	0.1	2	0	104	99	41	40

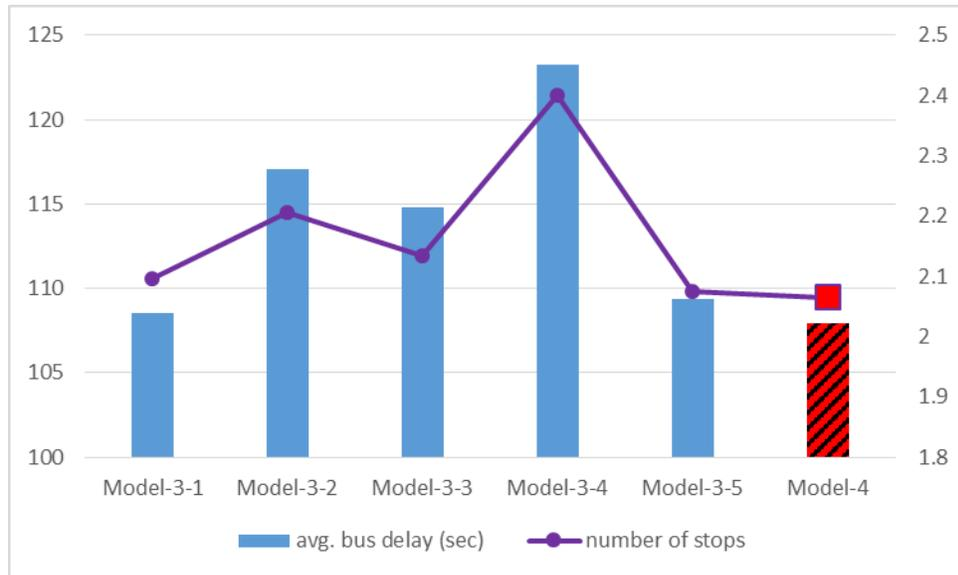

Figure 16. Simulation results by Model-3 with varying parameters and by Model-4

From Figure 16, it is noticeable that Model-4 significantly outperforms Model-3 except under some special sets of parameters. This further justifies the need to analyze the stochastic properties and the impacts on the resulting performance.

Simulation evaluation

The simulation evaluation includes only Models 1, 2, 4 and 5, but not Model-3. The signal plans generated by these models are applied in the aforementioned VISSIM network. The following measures of effectiveness are selected for model assessment: average bus vehicle delay, average passenger car delay, average person delay, and average number of stops of all vehicles. Given the

loading factors and vehicle flows for buses and passenger cars, the average person delay is computed with the following equation:

$$d_p = \frac{\rho_c \cdot q_c \cdot d_c + \rho_b \cdot q_b \cdot d_b}{\rho_c \cdot q_c + \rho_b \cdot q_b} \quad (39)$$

where, d_p , d_c and d_b denote the average person delay, average bus delay, average passenger car delay, respectively; ρ_c and ρ_b are the loading factors of passenger cars and buses; q_c and q_b are the flow rates of passenger cars and buses at the target arterial. Comparison results with respect to these performance measures are shown in Figure 17.

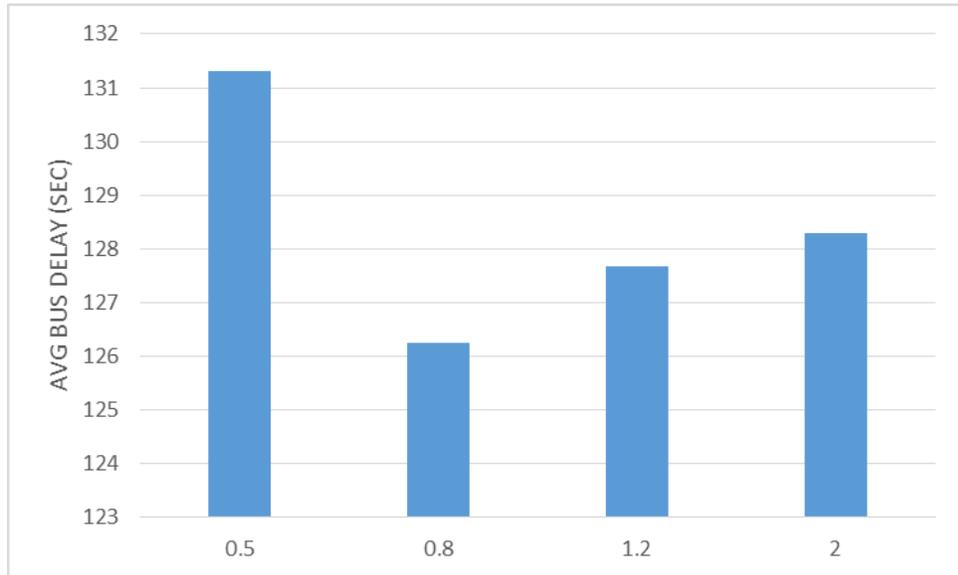

Figure 17 (A) Average Bus Delay

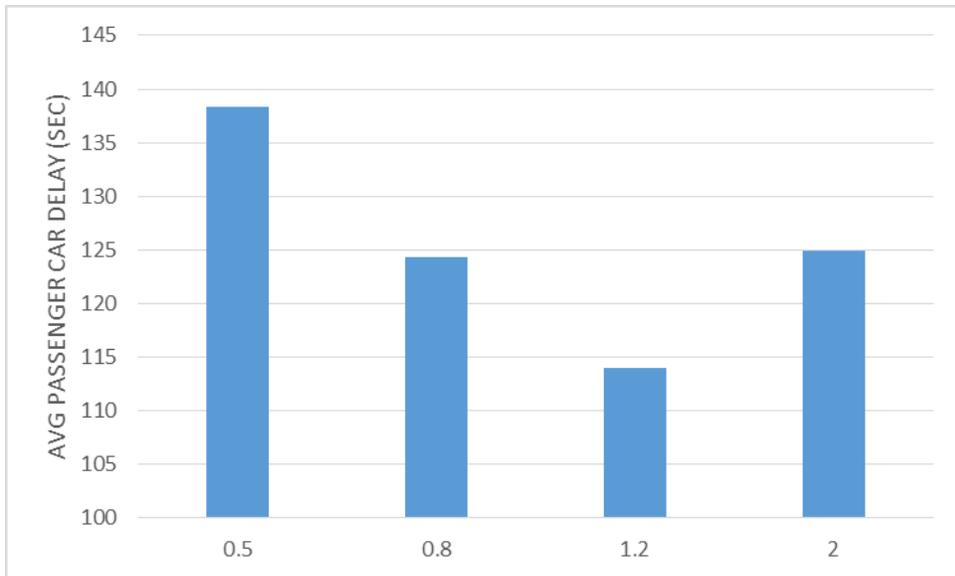

Figure 17 (B) Average passenger car delay

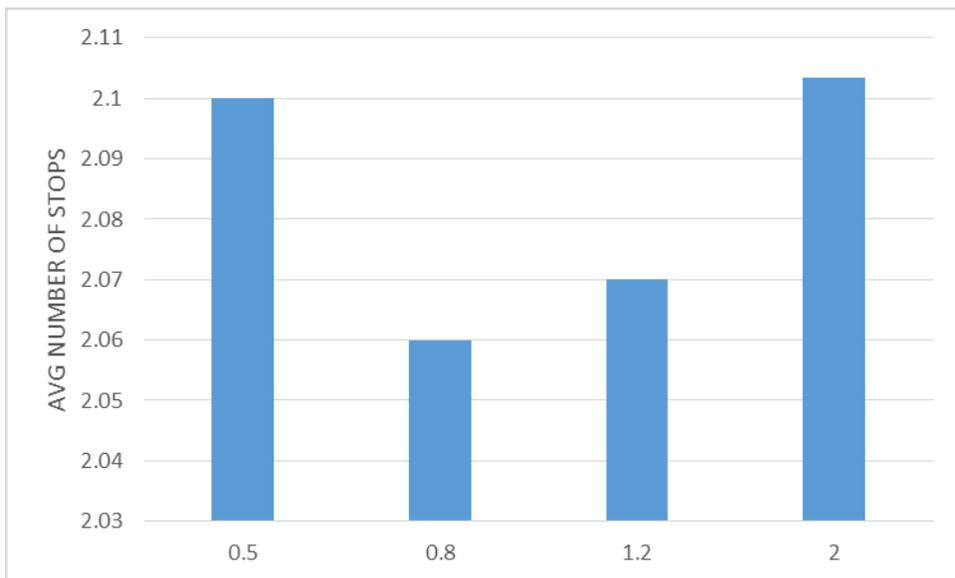

Figure 17 (C) Average per person delay

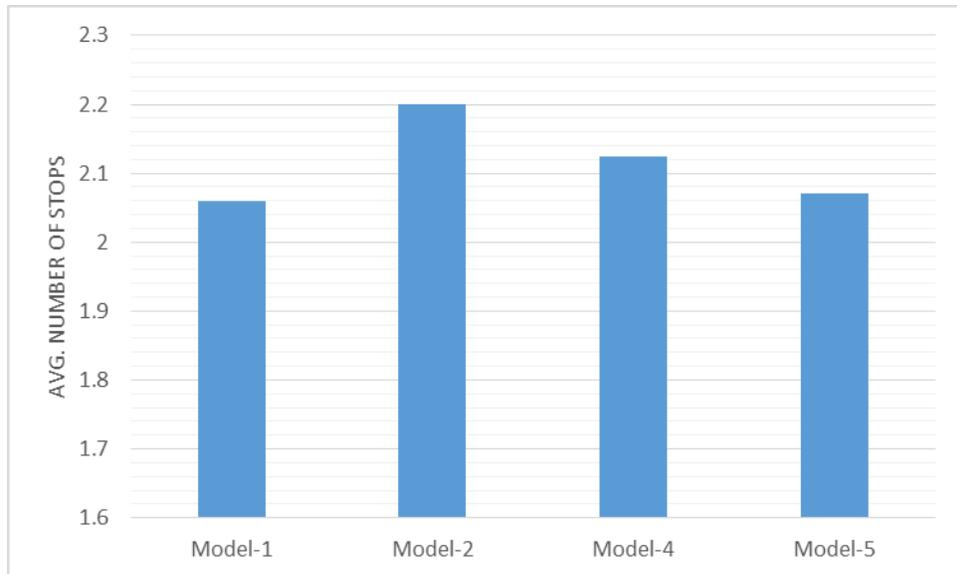

Figure 17 (D) Average number of stops

Figure 17. Comparison of Model's Performance Measures

Several key findings from the comparison are summarized below:

1. As shown in Figures 17(A) and (D), the models, which take bus progression into consideration, are able to offer operational benefits to bus vehicles on the target arterial, evidenced by the reduction in the average bus delay. Due to the trade-off nature, these models may also cause an increase in the average passenger car delay (See Figure 17(B)).
2. The proposed Model-2 and Model-4 can outperform Model-1 in terms of reducing average bus delay. Also, further comparison between Model-2 and Model-4 reveals that Model-2 may yield a slight reduction in bus delay. This is due to the fact that Model-2 has ignored the stochastic nature of bus dwell

time at bus stops. As such, only a small part of its bands can facilitate the progression of buses.

3. Model-4, but not with Model-5, may yield a higher passenger car delay than Model-1.
4. Since Model-5 is designed to benefit both buses and passenger cars concurrently, it may inevitably yield smaller bus bands than with Model-4. However, neither type of vehicles will experience a quite high delay, and both buses and passenger cars can be benefited from using Model-5.
5. In conclusion, Model-4 outperforms Model-2, and Model-5 is more effective than both Model-1 and Model-4. However, Model-5 should only be applied when the difference between the volumes of these two types of vehicles is not significant, because the constraints in Model-5 guarantee the existence of progression bands for both buses and passenger cars.

5.3. *Sensitivity Analysis*

Based on Eq. (44), one can note that the system's performance is quite sensitivity to the preference factor k , as defined in Eq. (44). This section further presents the sensitivity analysis of Model-5 with respect to the ratio between the number of passengers on buses and passenger cars. Table 5 shows the list of loading factors used in the numerical analysis, where other inputs remain unchanged. The signal plans generated by Model-5 for those four cases are applied to the VISSIM simulation, and the resulting performance measures are shown in Figure 18.

Table 5. Adjusted loading factors and passenger ratios between two types of vehicles

Loading factor on buses	Passenger ratio
12	0.8
18	1.2
30	2
7.5	0.5

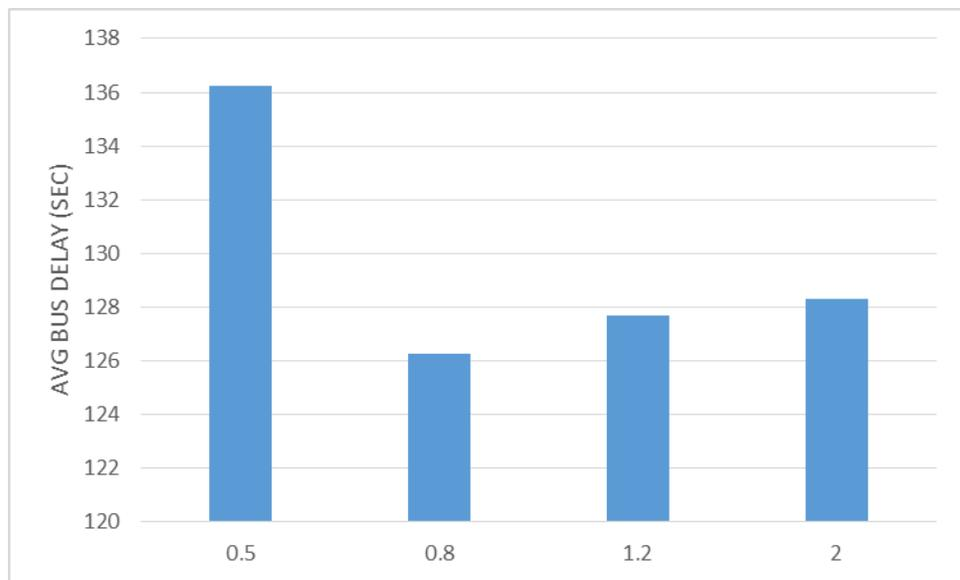

Figure 18 (A) Average Bus Delay

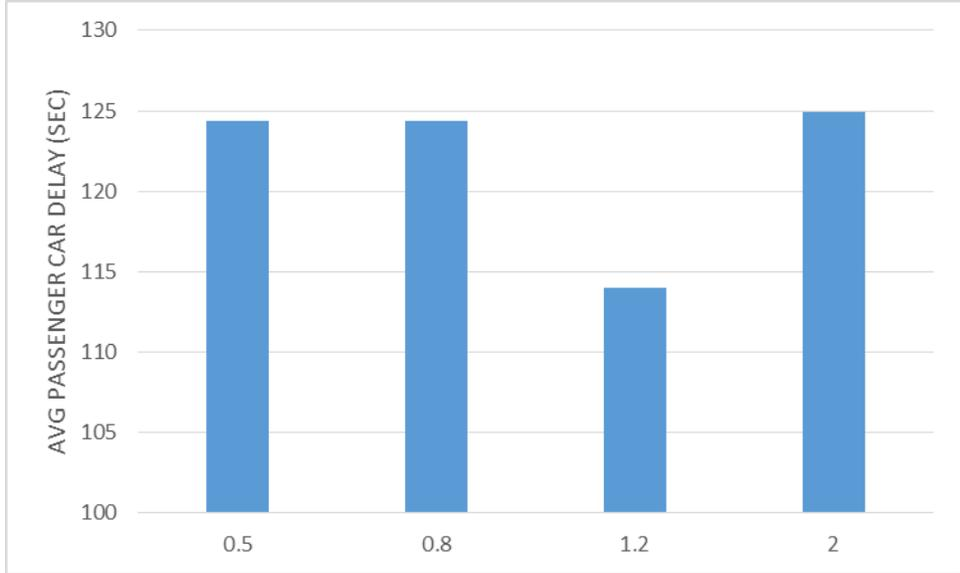

Figure 18 (B) Average passenger car delay

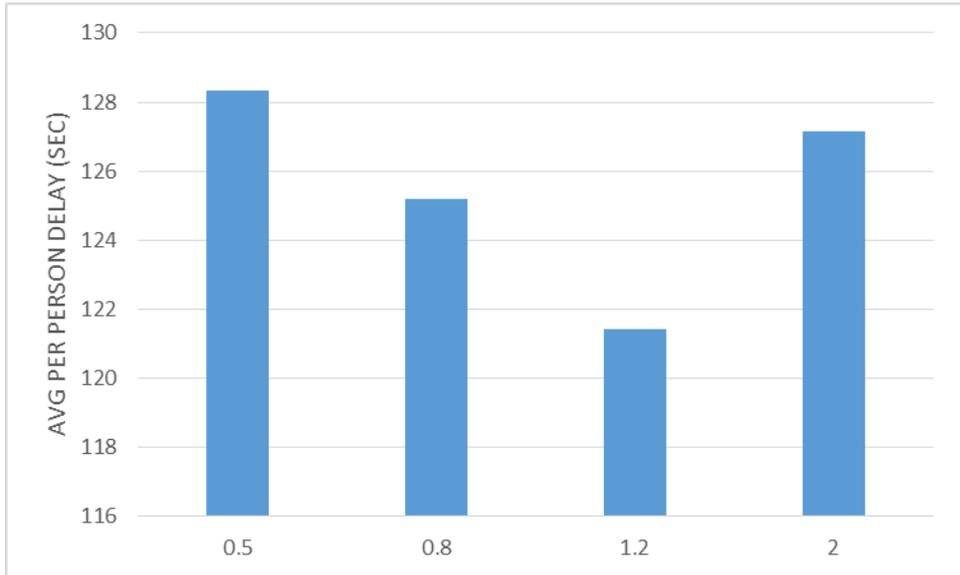

Figure 18 (C) Average per person delay

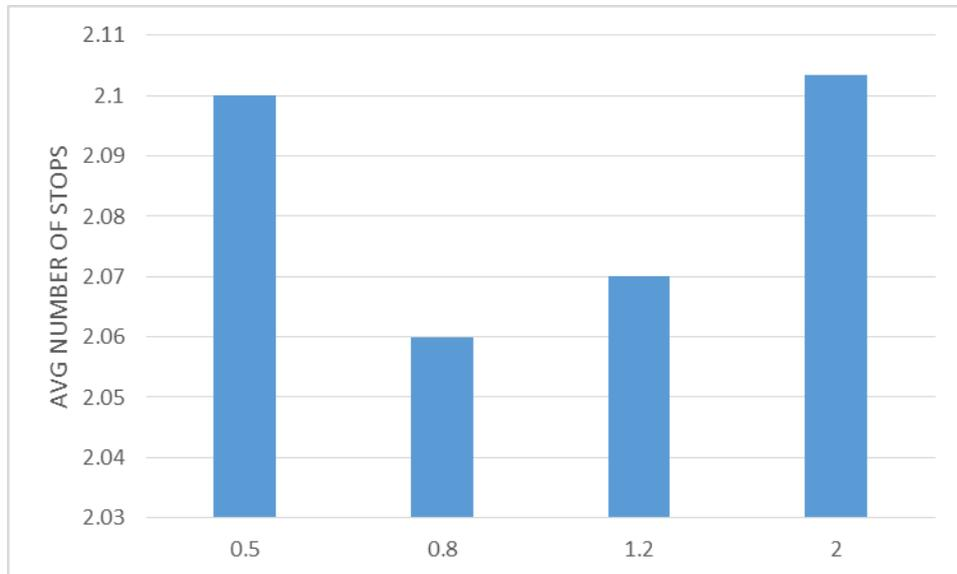

Figure 18 (D) Average number of stops

Figure 18. Model-5's Performance Measures with Different Passenger ratios

Based on the results in Figure 18, one can find that Model-5, an integrated progression model that accounts for both buses and passenger cars, performs better when the ratio between passengers on the two types of vehicles is close to 1. This is consistent with the expectation that the Model-5 is applicable when the difference between the numbers of passengers on these two types of vehicles is not significant. When the number of passengers in one vehicle type far exceeds the other type, the conventional signal progression model or Model-4 should be preferred.

Chapter 6: Conclusions and Future Study

6.1. Conclusions

Due to the limited functions of the active transit signal priority control and the strengths of arterial signals, this study has developed a bus progression system to facilitate bus movements on an arterial, but have the minimal impact to the side-street traffic. Given the cycle length and green splits at each intersection, the proposed bus-based progression models have taken the bus stops as the control points, and provided variable bus green bands along the arterial.

The key features of the developed model include: 1) the impact of bus dwell time at a bus stop between intersections on the progression design; 2) the stochastic nature of bus dwell times; 3) the capacity of bus stops; and 4) the competition on the green band between buses and passenger cars. To deal with the stochastic nature of bus dwell time, this study has introduced some control parameters to capture the relations between the arriving and departing bandwidths at bus stops. To prevent the potential spillbacks of buses at a stop, this study has developed a set of constraints to properly limit the bandwidths. An integrated model that is able to balance the bus and passenger car bandwidths has also been formulated to optimize the interrelations between these two types of progression bands.

To evaluate the effectiveness of the developed model, this study has further conducted extensive laboratory experiments with VISSIM. The simulation results demonstrate that the proposed model can significantly reduce both bus passenger

delays and average person delays for vehicles in the entire network, compared to the conventional progression models. The proposed integrated model also outperforms all other models in minimizing the delays of all arterial users.

6.2. Future research

Despite the progress made in this study, much remains to be studied for a full-scale deployment of a bus-band progression system. Among those, one critical issue is to develop a set of rigorous criteria that can compute the trade-off between bus-based and passenger-car-based progression models, and select the proper one in real time based on the detected traffic conditions. The second imperative issue is to increase the computing efficiency of the model's solution algorithm, and ensure that the optimal results can be implemented effectively and efficiently in real time, and also be dynamically operated under various traffic conditions. An extensive sensitivity analysis with field data and simulation experiments shall also be conducted to identify critical factors that may degrade the quality of the bus progression model developed in this research.

Bibliography

1. Smith, W., Westinghouse Airbrake Co. and Institute of Public Administration. Study of Evolutionary Urban Transportation, Vol. I-III. U.S. Department of Housing and Urban Development. 1968.
2. Ludwick, S. and John Jr. (1974) Simulation of an unconditional preemption bus priority system. Report MTP-400, Yhe Mitre Corporation
3. Dion F. and Hesham R. (2005) Integration Transit Signal Priority with Adaptive Traffic Signal Control Systems, presented at 84th Annual Meeting of the Transportation Research Board, Washington, D.C.
4. Evans H. and Skiles G. (1970) Improving public transit through bus preemption of traffic signals. In *Traffic Quarterly*, Vol.24, No.4, pp. 531-543.
5. Tamoff P. J. (1975) The results of FHWA urban traffic control research: an interim report. *Traffic Engineering*, 45 (4), 27-35.
6. MacGowan J. and Fullerton I. J. (1979) Development and testing of advanced control strategies in the urban traffic control system. *Public Roads*, 43 (3), pp.97-105.
7. Allsop R. E. (1977) Priority for buses at signal-controlled junctions: some implications for signal timings. Proceedings of the 7th International Symposium on Transportation and Traffic Theory, Kyoto, August 1977. In *Transportation and Traffic Theory* (Edited by T. Sasaki and T. Yamaoka) pp. 247-270. Kyoto: The Institute of Systems Science Research.
8. Cottinet M., Breteque A., Henry J. J. and Gabard F. (1980) Assessment by observation and by simulation studies of the interest of different methods of bus preemption at traffic lights. Proceeding of the international Symposium on Traffic Systems, Berkeley, California, Vol.2, pp. 92-105.
9. Lin, Y., X. Yang, G.L. Chang, and N. Zou. (2013b) Transit Priority Strategies for Multiple Routes Under Headway-Based Operations. In *Transportation Research Record: Journal of the Transportation Research Board*, No. 2356, Transportation Research Board of the National Academies, Washington, D.C., 2013, pp. 34-43.
10. Lin, Y., X. Yang, N. Zou, L. Jia, and Shu. (2013a) A New Passive Transit Signal Priority Control at Urban Arterials. *Journal of Northeastern University: Natural Science (In Chinese)*, 2013, Vol. 34, No. 9
11. Lin, Y.J., Yang, X.F., Zou, N, and Jia L. (2013c) Real Time Bus Arrival Prediction: A Case Study of Jinan China, *Journal of Transportation Engineering ASCE*, 139(11):1134-1140.

12. Urbanik, I. I. Priority treatment of buses at traffic signals. *Transportation Engineering*, 1977, pp. 31-33.
13. Garrow, M., and R. Machemehl. Development and Evaluation of Transit Signal Priority Strategies. Presented at the 77th Annual Meeting of the Transportation Research Board, Washington, D.C., 1998.
14. Ma W., and Yang X. A Passive Transit Signal Priority Approach for Bus Rapid Transit System. ITSC, Seattle: IEEE, 2007, pp. 413-418.
15. Morgan, J. T., & Little, J. D. (1964). Synchronizing traffic signals for maximal bandwidth. *Operations Research*, 12(6), 896-912.
16. Gartner N. H., S. F. Assmann, F. Lasaga, and D. L. Hou. A multi-band approach to arterial traffic signal optimization. *Transportation Research B; Methodological*, Vol. 25, No. 1, 1991, pp. 55-74.
17. Little, J., M. D. Kelson, and N. H. Gartner. MAXBAND: A Program for Setting Signals on Arteries and Triangular Networks. In *Transportation Research Record: Journal of the Transportation Research Board* No. 795, Transportation Research Board of the National Academies, Washington, D.C., 1981, pp. 40-46.
18. Li, J. Q. Bandwidth Synchronization Under Progression Time Uncertainty. *Intelligent Transportation Systems, IEEE Transactions on*, 2014, Vol. 15 Issue. 2
19. Yagar, S., and B. Han. A procedure for real-time signal control that considers transit interference and priority. *Transportation Research Part B: Methodological*, Vol. 28, No. 4, 1994, pp. 315-331.
20. Chang, G.L., M. Vasudevan, and C. Su. Modelling and evaluation of adaptive bus-preemption control with and without Automatic Vehicle Location systems. *Transportation Research Part A: Policy and Practice*, Vol. 30, No. 4, 1996, pp. 251-268.
21. Ling, K., and A. Shalaby. Automated Transit Headway Control via Adaptive Signal Priority. *Journal of Advanced Transportation*, Vol. 38, No. 1, 2004, pp. 45-67.
22. Hounsell, N.B., B.P. Shrestha, J.R. Head, S. Palmer, and T. Bowen. The Way ahead for London's Bus Priority at Traffic Signals. *IET Intelligent Transport Systems*, Vol. 2, No. 3, 2008, pp. 193-200.
23. Skabardonis, A. Control strategies for transit priority. In *Transportation Research Record: Journal of the Transportation Research Board*, No. 1727, Transportation Research Board of the National Academies, Washington, D.C., 2000, pp. 20-26.
24. Hounsell, N.B., and J.P. Wu. Public transport priority in real-time traffic control systems. *Applications of advanced technologies in Transportation Engineering*, 1995, pp. 71-75.

25. Chang, E. C., Cohen, S. L., Liu, C., Chaudhary, N. A., & Messer, C. (1988). MAXBAND-86: Program for optimizing left-turn phase sequence in multiarterial closed networks In *Transportation Research Record: Journal of the Transportation Research Board* No. 906, Transportation Research Board of the National Academies, Washington, D.C., 1988, pp. 61-67
26. Cohen, S. L. Concurrent use of MAXBAND and TRANSYT signal timing programs for arterial signal optimization. In *Transportation Research Record: Journal of the Transportation Research Board* No. 906, Transportation Research Board of the National Academies, Washington, D.C., 1983, pp. 81-84
27. Ma, W., Yang, X., & Liu, Y. Development and evaluation of a coordinated and conditional bus priority approach. In *Transportation Research Record: Journal of the Transportation Research Board*, Transportation Research Board of the National Academies, Washington, D.C., 2010, 2145(1), pp. 49-58.
28. Chang, E. P., Messer, C. J., & Cohen, S. L. (1986). Directional weighting for maximal bandwidth arterial signal optimization programs In *Transportation Research Record: Journal of the Transportation Research Board*, Transportation Research Board of the National Academies, Washington, D.C., 1057, pp. 10-19.
29. Hisai, M. Delay-minimizing control and bandwidth-maximizing control of coordinated traffic signals by dynamic programming. *Transportation and Traffic Theory.*, 1987, pp. 301-308
30. Leuthardt, H. R. Design of a progressively timed signal system. *Traffic Engineering*, 1975, Vol. 45, pp.11-18
31. Little, J. D. The synchronization of traffic signals by mixed-integer linear programming. *Operations Research*, 1966, 14(4), pp. 568-594.
32. Cohen, S. L., & Liu, C. C. THE BANDWIDTH-CONSTRAINED TRANSYT SIGNAL-OPTIMIZATION PROGRAM (DISCUSSION AND CLOSURE) , In *Transportation Research Record: Journal of the Transportation Research Board*, Transportation Research Board of the National Academies, Washington, D.C., 1986, 1057, pp. 1-9.
33. Tsay, H. S., & Lin, L. T. NEW ALGORITHM FOR SOLVING THE MAXIMUM PROGRESSION BANDWIDTH (WITH DISCUSSION AND CLOSURE), In *Transportation Research Record: Journal of the Transportation Research Board*, Transportation Research Board of the National Academies, Washington, D.C., 1988, 1194, pp. 15-30.
34. Wallace, C. E., & Courage, K. G. (1982). ARTERIAL PROGRESSION--NEW DESIGN APPROACH., In *Transportation Research Record: Journal of the Transportation Research Board*, Transportation Research Board of the National Academies, Washington, D.C., 1982, 881, pp. 53-59.

35. Machemehl R. "Class Notes: CE 391L, Advanced Traffic Engineering", The University of Texas at Austin, Spring, 1996.
36. Zhang, W. H., Lu, H. P., Shi, Q., & Liu, Q. Optimal signal-planning method of intersections based on bus priority. *Journal of Traffic and Transportation Engineering (In Chinese)*, 2004, 4(3), pp. 49-53.
37. JI, Y. J., DENG, W., WANG, W., & ZHANG, W. H. Study on the Design of Signal Phase Based on Bus Priority Intersections. *Journal of Highway and Transportation Research and Development (In Chinese)*, 2004-12
38. FENG, Y., PEI, Y. L., & CAO, C. H. Study of single bus priority signal planning under the mixed traffic flow. *Journal of Harbin Institute of Technology (In Chinese)*, 2007-2.
39. Mirchandani, P., Knyazyan, A., Head, L., & Wu, W. An approach towards the integration of bus priority, traffic adaptive signal control, and bus information/scheduling systems. In *Computer-Aided Scheduling of Public Transport 2001*, pp. 319-334. Springer Berlin Heidelberg.
40. Zhou G.W. and Gan A. Determination of Optimal detector locations for transit signal priority with queue jumper lanes, In *Transportation Research Record: Journal of the Transportation Research Board*, 2006, No.1978, pp.123-129.
41. El-Reedy T. Y. and Ashworth R., The effect of bus detection on the performance of a traffic signal controlled intersection. *Transportation Research*, 1978, 12 (5), pp.337-342.
42. Cooper, B. R., Vincent, R. A., & Wood, K. Bus-actuated traffic signals-initial assessment of part of the Swansea bus priority scheme (No. TRRL LR925 Monograph), 1980.
43. Bowen G.T., Bretherton R.D., Landles J. R. and Cook D. J. (1994) Active Bus Priority in SCOOT. In *Road Traffic Monitoring and Control, Seventh International Conference*, pp.73-76.
44. Smith, H. R., Hemily, B., & Ivanovic, M. Transit signal priority (TSP): A planning and implementation handbook., ITS America, 2005
45. Balke K. N., Dudek C. L. and Urbanik II T. Development and Evaluation of an Intelligent Bus Priority Concept. *Presented at the 79th Annual Meeting of the Transportation Research Board*, 2000, Washington, DC
46. Janos M. and Furth P. G. Bus priority with highly interruptible traffic signals: simulation of San Juan's Avenida Ponce de Leon, In *Transportation Research Record: Journal of the Transportation Research Board*, Transportation Research Board of the National Academies, Washington, D.C., 2002, No.1811, pp.157-65.
47. Satiennam T., T. Muroi, Fukuda A. and Jansuwan S. An Enhanced Public Transportation Priority System for Two-lane Arterials with Nearside Bus Stops.

- In *Proceedings of the Eastern Asia Society for Transportation Studies*, 2005, Vol.5, pp.1309-1321.
48. Ma W. and Yu B. (2007) Serve Sequence Optimization Approach for Multiple Bus Priority Requests Based on Decision Tree. *Proceedings of the Seventh International Conference of Chinese Transportation Professionals Congress*.
 49. He Q., Head K.L. and Ding J. Heuristic Algorithm for Priority Traffic Signal Control. In *Transportation Research Record: Journal of the Transportation Research Board*, 2011, No.2259, pp.1-7.
 50. Kulash D. (1971). Routing and scheduling in public transit systems, dissertation presented to Massachusetts Institute of Technology, at Cambridge, Mass., in partial fulfillment of the requirements for the degree of Doctor of Philosophy.
 51. Ling, K., & Shalaby, A. Automated transit headway control via adaptive signal priority. *Journal of advanced transportation*, 2004, Vol. 38(1), pp. 45-67.
 52. Altun S.Z. and Furth P.G. Scheduling Buses to Take Advantage of Transit Signal Priority. In *Transportation Research Record: Journal of the Transportation Research Board*, Transportation Research Board of the National Academies, Washington, D.C., 2009, No.2111, pp.50-59.
 53. Yan F., Li K., Sun J. Detector Location for Transit Signal Priority at Intersection with Countdown Signals. *Journal of Transportation Information and Safety (In Chinese)*, 2009(6): pp. 79-83.