

## ABSTRACT

Title of Document: AVIAN/HUMAN ARCHITECTURE  
Jane R. Atalig, Master of Architecture, 2013

Directed By: Clinical Associate Professor, Michael A.  
Ambrose, Department of Architecture

Belonging to the Commonwealth of the Northern Mariana Islands (CNMI), Rota, the southernmost island in the Northern Mariana Island archipelago, is home to a naturally protected avian sanctuary that hosts critically endangered species of birds found nowhere else in the world. The island's unique environment has attracted the interest of academic institutions and international visitors focused on learning more about the island's ecosystem. While attempting to address the CNMI's tourism issues, the most recent tourism master plan for the islands, *NMI Tourism Master Plan 2012-2016*, fails to recognize Rota as a major candidate for economic growth. This thesis proposes a solution to both address tourism issues as well as educate locals and visitors of the importance of ecological sustainability through critical and creative exploration of the interaction between avian and human architecture.

AVIAN/HUMAN ARCHITECTURE

By

Jane R. Atalig

Thesis submitted to the Faculty of the Graduate School of the  
University of Maryland, College Park, in partial fulfillment  
of the requirements for the degree of  
Master of Architecture  
2013

Advisory Committee:

Clinical Associate Professor Michael A. Ambrose, Chair

Professor Garth Rockcastle, FAIA, Member

Associate Professor Madlen Simon, AIA, Member

© Copyright by  
Jane R. Atalig  
2013

## Preface

Every living species needs a combination of food, water, space and shelter – habitat – to survive. In the Mariana Islands, the movement towards increased commercial, residential, and institutional development in the hopes for future economic success has negatively impacted the avifauna ecosystem. While water is not necessarily the greatest concern for these birds, food, space and shelter are in steep decline due to human settlement and benign neglect.

The introduction of non-native species such as the cat and monitor lizard has also negatively impacted the native avifauna population. The original intention for the introduction of these two species was to control the rat population that was thriving off local farms; however, it was unforeseen that these predators would also prey on the birds—especially on the native birds that have never known predators in their natural ecosystem.

As a designer, I believe that there is a potential solution to almost everything and that critical analysis and creative thinking are necessary to finding the best answers. This thesis will challenge the notion that habitat loss is the inevitable result of human development and question how architecture can positively impact the avifauna habitat alongside the needs for economic success. My primary goals are to illustrate how architecture can enhance, support and protect and unify habitat. Secondary to this, I intend to utilize architecture as a tool to promote ecological conservation and environmental protection through an education that is experientially derived rather than proscribed. And thirdly, I would like to create an architecture that

expresses an appreciation for the local avifauna in a way that is less literal and more phenomenological.

## Acknowledgement

After successfully defending my thesis on the 17<sup>th</sup> of December 2013, I feel that it is necessary to thank the University of Maryland, School of Architecture for not only molding me into the design thinker that I am today but also for providing me with this great opportunity to explore a subject that is important to me. As much as I would like to claim that I alone achieved this body of work, I simply cannot. This project would not have been possible without the numerous conversations with my colleagues, the various exchanges of ideas with my committee members during our meeting sessions and of course the collaboration with various experts--Local and US Fish & Wild Life, Phil Hannon of the University of Washington's Avian Behavioral Ecology Team, and Rota's Government. Thank you all for making this the greatest learning experience I have ever had.

## Dedication

I would like to dedicate this body of research to my father, Francisco M. Atalig, my mother, Ofelia R. Atalig, and the people of Rota. I am sincerely proud of your steadfast efforts to preserve the island's natural beauty and cannot wait to return home one day. Keep up the bbq fire, turn up the fiesta music, and never forget to wave at your neighbors on the main road. *Biba Luta!*

## Table of Contents

Preface.....	ii
Acknowledgement.....	iv
Dedication.....	v
Table of Contents .....	vi
List of Tables .....	ix
List of Figures.....	x
Chapter 1: Overview .....	1
Northern Mariana Islands: Tourism Master Plan 2012-2016.....	1
The State of Tourism in the Northern Mariana Islands .....	1
Market Highlights .....	2
Top Five.....	4
Key Points .....	5
Rota Island as a Solution to the state of NMI Tourism .....	6
"Nature's Treasure Island" .....	6
A Key Difference.....	7
Niche Market Opportunity .....	8
Bird Watching: A Growing Niche Market .....	8
Avian Enthusiast Population .....	8
Avian Enthusiast Profile.....	9
Bird Watching Population and CNMI Tourism Needs .....	10
Eco-Tourism.....	12
Concept and Current State.....	12
The Fastest Growing Niche Market.....	12
Rota and Eco-Tourism.....	13
CNMI Conservation Practice .....	14
Chapter 2: Site .....	15
Rota .....	15
Why Rota.....	15
Demographic and Environmental Facts .....	16
Topography .....	16
Roads .....	17
Land Use.....	18
Critical Habitat .....	19
I'Chenchon Park Bird Sanctuary .....	20
History and Location .....	21
Human Perspective/ Existing Conditions .....	21
Avian Perspective .....	22
Chapter 3: Avian Study.....	24
Observing Birds.....	24
Institutions and Organizations.....	25
Academic.....	25
Government and other Organizations.....	26



The Importance of Birds .....	26
Agents of Dispersal .....	26
Insect Exterminators .....	26
Bio-indicators .....	27
Primary Behaviors .....	27
Diet .....	27
Mating .....	27
Nesting .....	28
Rota's Birds .....	29
Chapter 4: Precedent Study .....	32
Path .....	32
Cornell Lab of Ornithology .....	32
The Highline .....	34
Placement .....	35
Materials .....	37
Local Wood .....	37
Bamboo .....	38
Scale .....	38
Chapter 5: Proposal .....	39
Path Study .....	39
Existing Path .....	39
Strategies for Extension .....	40
Proposed .....	41
Support: The Vine .....	45
Purpose .....	46
Impact on avian habitat .....	47
Impact on humans .....	48
Support: The Canopy .....	49
Purpose .....	50
Impact on avian habitat .....	52
Impact on humans .....	52
Enhance: The Burrow .....	53
Purpose .....	53
Impact on avian habitat .....	54
Impact on humans .....	56
Protect: The Nest .....	57
Purpose .....	57
Impact on avian habitat .....	58
Impact on humans .....	60
Unify: The Cliff .....	62
Purpose .....	62
Impact on avian habitat .....	64
Impact on humans .....	65
Chapter 6: Conclusion and Reflections .....	68
The Project .....	68
Final Reflections .....	69

Bibliography .....71

## List of Tables

Table 1: FY 2011 Trip Statistics	3
Table 2: FY 2011 Traveling Party Statistics	3
Table 3: FY 2011 Average Daily Expenditure	3
Table 4: Top Reasons for Visiting	4
Table 5: Top Activities during Stay	4
Table 6: Top Activities Visitors Would Like to See More Of	5
Table 7: Population of Bird Watching and Conservation Groups in the US and UK (2013)	11

## List of Figures

Figure 1: Total Arrivals in the Northern Mariana Islands since 1981.	2
Figure 2: Number of Birdwatchers Worldwide (in Millions).	9
Figure 3: Birdwatchers by Income (2006).	10
Figure 4: Birdwatchers by Age Groups.	10
Figure 5: Sustainability Level	11
Figure 6: International Tourist Arrivals (% change over same period of the previous year).	13

## List of Illustrations

Illustration 1: View of Songsong Village (Downtown)	6
Illustration 2: View of Songsong Village (Downtown area)	15
Illustration 3: Panoramic of Rota Island Massing	16
Illustration 4: Topography drawing at 10 meter increments.	17
Illustration 5: Roads, Topography at 50meter increments, Protected Habitats	18
Illustration 6: Land use map (2013)	19
Illustration 7: Critical Avian Habitats and Conservation Areas	20
Illustration 8: Panoramic of Bird Sanctuary	20
Illustration 9: Aerial View.	21
Illustration 10: View from bottom terrace to main overlook.	21
Illustration 11: University of Washington's Rota Avian Behavioral Ecology Program Team: Intern, Phil Hannon, And Sarah Faegre (sitting from Left to Right).	25
Illustration 12: Small bird nest construction.	28
Illustration 13: Medium bird nest construction.	29
Illustration 14: Large bird nest construction.	29
Illustration 15: Taxonomy sheet summarizing range avian study.	30
Illustration 16: Site Plan of Cornell Lab of Ornithology	33
Illustration 17: Lowered seating area from street view.	34
Illustration 18: Lowered seating area interior view.	34
Illustration 19: Entry Point.	34
Illustration 20: Clingmans Dome, TN	36
Illustration 21: Kielder Observatory, Northumberland, UK	36
Illustration 22: Korkeasaari Island Lookout, Helsinki, Finland	36
Illustration 23: An Turas Shelter, Northumberland, UK	36
Illustration 24: Kiro San Observatory, Japan	36
Illustration 25: Women at War Museum, Yorkshire, UK	36
Illustration 26: Aurland Lookout, Aurland, Norway	36
Illustration 27: Grand Canyon Skywalk, Skywalk, AZ	36
Illustration 28: House on the Rock, WI	36
Illustration 29: Edge	41
Illustration 30: Enclosed	41
Illustration 31: Extended	41
Illustration 32: Proposed path	42
Illustration 33: Proposed path overlaid on existing conditions with habitat zones	42
Illustration 34: Proposed Paths and Pause Points in Red	43
Illustration 35: Burrow Plan	43
Illustration 36: Vine Plan	43
Illustration 37: Canopy Plan	43
Illustration 38: Nest Plan	43
Illustration 39: Cliff Plan	43
Illustration 40: Aerial Perspective with Proposal	44
Illustration 41: Vine Details	45
Illustration 42: Vine Perspective	46
Illustration 43: Vine Section	46

Illustration 44: Canopy Details	49
Illustration 45: Goal of Canopy Scheme	50
Illustration 46: Canopy Perspective	51
Illustration 47: Burrow Section Perspective	53
Illustration 48: Burrow Steel Pipe Treatment	54
Illustration 49: Steel Rod and Vibration Movement Diagram	54
Illustration 50: Burrow Construction Process	55
Illustration 51: Intention for Burrow Perspective	56
Illustration 52: Nest Perspective	57
Illustration 53: Structural Details without Camouflage Layer	58
Illustration 54: Metaphorical Parallel Construction	59
Illustration 55: Volume Detail	60
Illustration 56: Knotting Detail	60
Illustration 57: Intention of Nest Scheme	61
Illustration 58: Cliff Section Perspective	62
Illustration 59: Construction Detail for Minimal Impact on Habitat	63
Illustration 60: Typical cliff-edge path condition	64
Illustration 61: Bird Perspective	64
Illustration 62: Typical Red and Brown Booby behavior outside of path.	65
Illustration 63: Mirror Device	66
Illustration 64: Perspective of Cliff Scheme from Top of Site	67

## Chapter 1: Overview

### *Northern Mariana Islands: Tourism Master Plan 2012-2016*

#### The State of Tourism in the Northern Mariana Islands

In 2010, the Marianas Visitors Authority (MVA) hired Management Analysis, Incorporated (MAI), an analytical-support-consulting agency located in Vienna, VA, to assist in the preparation of a five-year master plan for tourism in the Northern Mariana Islands of Saipan, Tinian and Rota. Their findings were presented to the office of Governor Benigno R. Fitial and Lieutenant Governor Eloy S. Inos in a document entitled Northern Mariana Islands: Tourism Master Plan 2012-2016<sup>1</sup>. It currently serves as the economic development plan aimed at revitalizing the NMI's tourism industry.

MAI states in the 2012-2016 tourism plan that:

For more than 30 years, tourism has provided essential economic support for the people of Saipan, Tinian and Rota in the US Commonwealth of the Northern Mariana Islands (CNMI). The islands' close proximity to major Asian cities, their natural beauty, tropical climate, and abundant historical sites make this an ideal tourist destination.

The following figure illustrates tourist patterns since the 1980s:

---

<sup>1</sup> Management Analysis, Incorporated. (2012). *Northern Mariana Islands Tourism Master Plan 2012-2016*. Marianas Visitors Authority. Vienna, VA: Management Analysis, Incorporated.

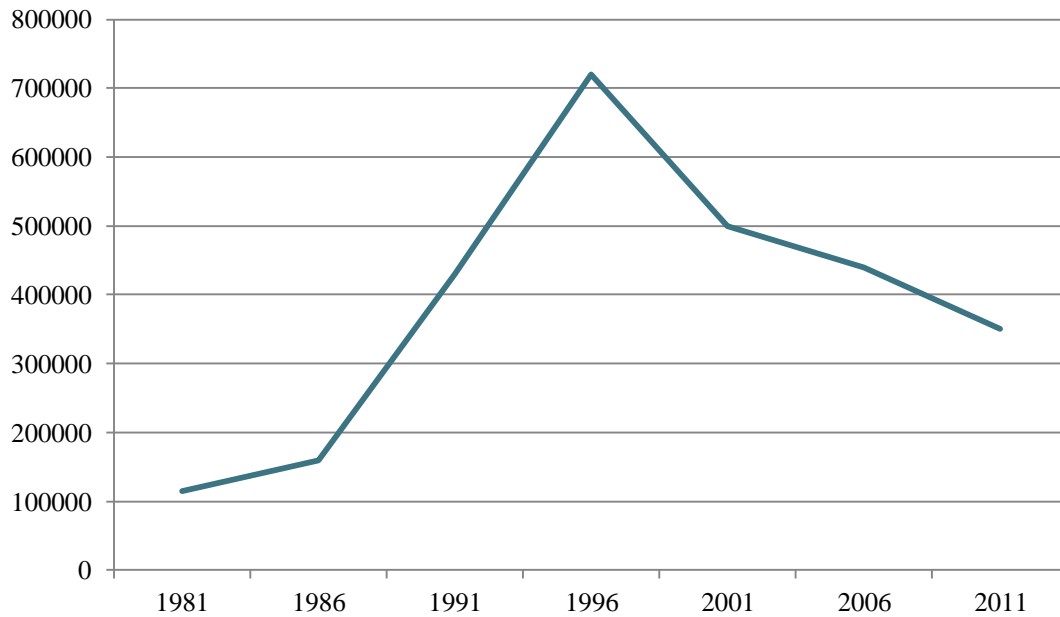

**Figure 1: Total Arrivals in the Northern Mariana Islands since 1981.**

As you can see, the late 1980s and first half of the 1990s experienced a rapid growth in tourism. In 1997, tourism peaked with approximately 727,000 visitors but has since been in decline. In 2011, the islands only received 338,646 visitors, a drop of 53% over their peak year. The tourism master plan reports that insufficient air transportation primarily caused the drop. MAI's analysis concluded that the NMI requires a minimum of 572,000 visitors annually to adequately sustain the tourist industry in today's market.

#### Market Highlights

According to the master plan's report on market highlights from the NMI's 2011 tourism records, a majority of the tourists to the island are couples who stay for an average of four nights. In family parties, the children primarily range from 2 to 12



years of age. And finally, although Russians spend the most money per day, they make up the smallest market group. You can see the information broken down below:

**Table 1: FY 2011 Trip Statistics**

<b>Market</b>	<b>Total Visitors</b>	<b>Average Length of Stay</b>	<b>Expenditure w/o hotel</b>
<b>Japan</b>	148,634	3.3 nights	\$758.20
<b>Korea</b>	106,483	4 nights	\$568.73
<b>China</b>	46,451	4 nights	\$681.40
<b>Guam / US Military*</b>	8,928	4 nights	\$652.37
<b>Russia</b>	5,092	12.4 nights	\$4,129.00

\* Guam & US Military inter-island visitors primarily travel for business and travel either alone or with business associates.

**Table 2: FY 2011 Traveling Party Statistics**

<b>Market</b>	<b>Traveling w/ Spouse</b>	<b>Traveling w/ Children</b>	<b>Age of Children</b>
<b>Japan</b>	50.2%	24.6%	2-12
<b>Korea</b>	67.3%	37.2%	2-12
<b>China</b>	39.5%	18.1%	7-18
<b>Guam / US Military*</b>	n/a	n/a	n/a
<b>Russia</b>	57.1%	57.1%	2-6

**Table 3: FY 2011 Average Daily Expenditure**

<b>Market</b>	<b>Length of Stay</b>	<b>Expenditure without Hotel</b>	<b>Average Daily Expenditure</b>
<b>Japan</b>	3.3 nights	\$758.20	\$229.75
<b>Korea</b>	4 nights	\$568.73	\$142.18
<b>China</b>	4 nights	\$681.40	\$170.35
<b>Guam/US Military</b>	4 nights	\$652.37	\$163.09
<b>Russia</b>	12.4 nights	\$4,129.00	\$332.98

## Top Five

In looking at the top five results for reasons for visiting the Mariana Islands, the NMI's tropical climate ranks as number one with nature activities right after. According to the top five activities visitors carry out during their stay, water sports and island adventure opportunities rank at the top of the list. And finally, nature activities come up the most in the “top activities visitors would like to see more of” category.

**Table 4: Top Reasons for Visiting**

	<b>1</b>	<b>2</b>	<b>3</b>	<b>4</b>	<b>5</b>
<b>Japan</b>	Tropical Climate	Inexpensive Travel	Nature Activities	Short Travel Distance	Shopping
<b>Korea</b>	Tropical Climate	Nature Activities	Short Travel Distance	Safe Place to Visit	Scuba Diving
<b>China</b>	Tropical Climate	Nature Activities	Scuba Diving	Shopping	Short Travel Distance
<b>Guam/ US Military</b>	Tropical Climate	Business Trip	Visit Friends/Relatives	Golf	Scuba Diving
<b>Russia</b>	Tropical Climate	Safe Place to Visit	Fishing	Historical Sites	Shopping

**Table 5: Top Activities during Stay**

	<b>1</b>	<b>2</b>	<b>3</b>	<b>4</b>	<b>5</b>
<b>Japan</b>	Snorkeling	Island* Tour	Water/Beach Sports	<i>Managaha*</i> Tour	Hotel Spa
<b>Korea</b>	Snorkeling	<i>Managaha</i> Tour	Island Tour	Water park	Water/Beach Sports

<b>China</b>	Tinian Tour	<i>Managaha</i> Tour	Island Tour	Snorkeling	Jungle Tour
<b>Guam/ US Military</b>	n/a				
<b>Russia</b>	Snorkeling	Submarine ride	Island Tour	<i>Tapochau</i> * tour	Water sports on the beach

\* Island refers to Saipan.

\* *Managaha* is a small, uninhabited island off the coast of Saipan.

\**Tapochau* is the tallest mountain on Saipan.

**Table 6: Top Activities Visitors Would Like to See More Of**

	<b>1</b>	<b>2</b>	<b>3</b>	<b>4</b>	<b>5</b>
<b>Japan</b>	Nature / scenic attractions	Marine/ sea life exhibit	Shopping	B&B Hotels	Local Food
<b>Korea</b>	Local Food	Open /Night Market	Bed &Breakfast Hotels	Activities for Children and Families	Hiking trails
<b>China</b>	Marine /Sea Life Exhibit	Nature/ Scenic Attraction	Night Clubs	Open / Night Market	Local Food
<b>Guam/ US Military</b>	Shopping	Nature/Scenic Attractions	Camping/ Eco-Lodges	B&B Hotels	Open/Night Market
<b>Russia</b>	Shopping	Nature/Scenic Attractions	Night Clubs	Local Entertainment	Marine /Sea Life Exhibit

#### Key Points

- 1.) The CNMI needs to find ways to attract more long-stay tourists such as the Russians.
- 2.) Because nature/scenic attractions ranked high on both the "Top 5 Reasons for Visiting" and "Top 5 Activities Visitors Would Like to See More Of" lists, the CNMI needs to provide more opportunities for tourists to see and experience more local culture and nature-based activities.

- 3.) Although Rota is the least traveled island in the NMI, it has the greatest potential to provide opportunities to view indigenous landscapes and fauna.

The following section will discuss how Rota is a good candidate for economic growth through its unique environment among the Mariana Islands.

*Rota Island as a Solution to the state of NMI Tourism*



**Illustration 1: View of Songsong Village (Downtown)<sup>2</sup>**

"Nature's Treasure Island"

Within the NMI, Rota has been called "The Peaceful Island," and "Nature's Treasure Island."<sup>3</sup> Unlike the other NMI islands, Rota has crystal clear waters due to lack of industrial pollution. Its beaches and parks are pristine due to continual care by the locals who frequently use them. Additionally, Rota's jungles are lush and full of

---

<sup>2</sup> "Songsong Village lookout." Accessed 20 November 2013.  
<http://www.panoramio.com/photo/11941821>.

<sup>3</sup> Management Analysis, Incorporated. (2012). *Nothern Mariana Islands Tourism Master Plan 2012-2016*. Marianas Visitors Authority. Vienna, VA: Management Analysis, Incorporated.

indigenous animal and plant fauna due to the fact that it is the only island in the NMI that was spared from WWII destruction.

According to the MAI's report on Rota:

The experience of visiting Rota is distinctly different from the ambiance of other Mariana islands. In addition to its natural charms, Rota has many historic attractions that one can explore on a leisurely basis...The island is home to a mysterious As Nieves Quarry and several other ancient latte village sites, caves with ancient pictographs, and a number of Japanese era and WWII historical sites. High above *Songsong* Village, there is even a historic building from the Spanish times, the Santa Lourdes Shrine. A number of sites lie on private property and are open for tourist visitation by the families that own them.

Rota is an underwater wonderland for scuba divers, with beautiful coral gardens, reef walls, caves and shipwrecks. The clear water quality is among the best in the world... Added to the underwater mystique of Rota is the fact that a Manila Galleon, the *Santa Margarita* sank off the island in the 1600s. The shipwreck site was located in 1995, bringing international publicity, but artifacts have yet to be made available for public display.

A number of seasonal festivals--such as the annual "Fiesta de Borja Rota Fiesta" and competitive sporting events like the long-standing "Rota Blue Triathlon"--make Rota a fun and welcoming place to join in local activities.

As you can see, Rota contains all the features—nature attractions, genuine local culture, and even historic attractions<sup>4</sup>. Because both Saipan and Tinian offer similar attractions and the majority of Rota's lands are under protected for conservation purposes, Rota has struggled to advertise itself as a worthwhile place to see and has seen significantly fewer visitors each year.

#### A Key Difference

One of the recent key differences between Rota and other islands in the Mariana island chain is that Rota is snake free. In the 1950s<sup>5</sup>, Guam, the southernmost island in the Mariana Island chain, first detected the presence of brown tree snakes that were accidentally transported from South Pacific cargo carriers. In

---

<sup>4</sup> Ten of Rota's historic attractions are listed under the National Registry for Historic Places.

<sup>5</sup> "The brown treesnake on Guam." Accessed 20 November 2013.

<http://www.fort.usgs.gov/resources/education/bts/invasion/colonize.asp>.

1986, snakes made their way into Saipan's jungles. Soon after, in the 1990s, Tinian also became flooded with snakes. Because of the growing population of snakes on Guam, Tinian and Saipan, the bird population in NMI has been rapidly decreasing and more birds are becoming critically endangered. Recently, Guam has introduced their endemic bird, the Ko'ko bird, to Rota while they attempt to gain control over their snake population.

#### Niche Market Opportunity

Since Rota remains snake free and it already hosts a large bird sanctuary, Rota has the opportunity to brand itself as a unique place within the NMI where one can both observe and safely interact with native avian fauna. By marketing Rota as a great place for bird watching, it will both give the mainstream tourist groups a specific reason to travel to the island as well as attract a new group of international travelers that have a strong interest in birds. For at least the past ten years, local ornithologists and biologist have been visiting the island to study both the state of the Guam rail, migrating birds and the endemic birds on the island. A section in chapter three provides information on the different organizations and institutions affiliated with Rota's avifauna.

#### *Bird Watching: A Growing Niche Market*

##### Avian Enthusiast Population

According to the National Survey of Fishing, Hunting, and Wildlife-Associated Recreation, bird watching is the fastest growing recreational pursuit internationally. This is due to the fact that field guides and affordable optics have

become readily available and, more recently, the internet has provided a platform where people can share information and spark interest. The population growth of avian enthusiasts is charted below:

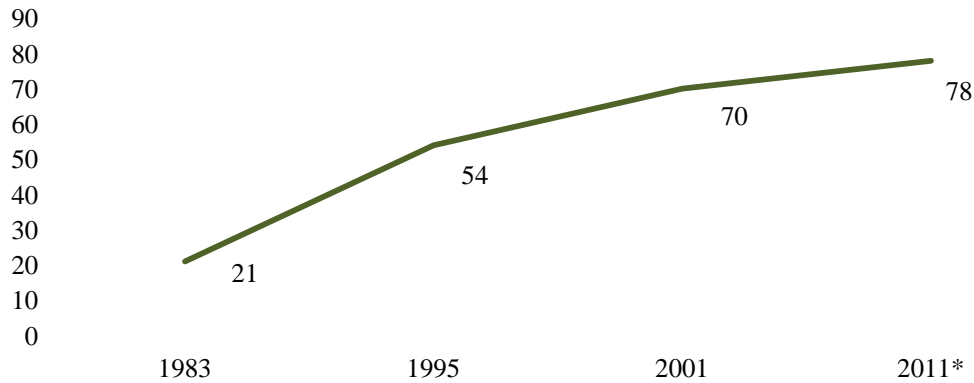

**Figure 2: Number of Birdwatchers Worldwide (in Millions).**

\* While 1983-2001 accounts for the population of birdwatchers worldwide, 2011 only accounts for the UK and US population.

#### Avian Enthusiast Profile

Enthusiasts find bird watching a favorite activity and the most dedicated birdwatchers spend a substantial amount of time and money in pursuit of this hobby. For many, bird watching is a competitive sport in which individuals race around and try to see as many species as possible within a particular time frame and area.<sup>6</sup> Otherwise, it is a carefree activity one can simply enjoy at one's leisure.

---

<sup>6</sup> Unwin, M. (2011). *The Atlas of Birds*. Brighton: Myriad Editions.

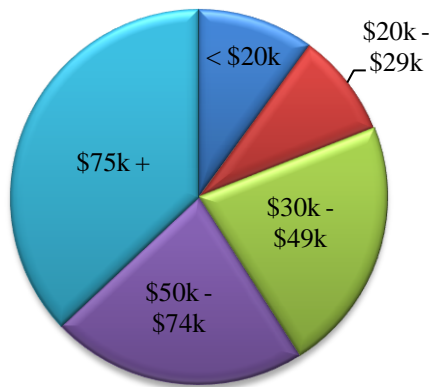

**Figure 3: Birdwatchers by Income (2006).**

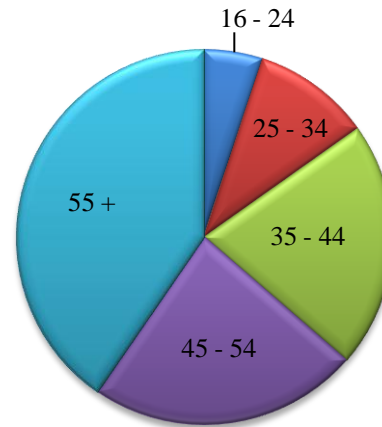

**Figure 4: Birdwatchers by Age Groups.**

The charts above illustrate that the majority of birdwatchers are affluent, older adults. According to birdwatcher profiles, birdwatchers are also known to be highly educated, love traveling, and interested in wildlife.<sup>7</sup>

#### Bird Watching Population and CNMI Tourism Needs

The main shareholders in the bird watching market include the US, UK, Continental Europe (Germany, Netherlands and France, in particular), and Australia. The US and UK serve as the primary stakeholders.<sup>8</sup> In 2006, the US's bird watching industry spent an estimated \$45 billion, the most revenue ever generated in this market. The UK followed with \$260 million.<sup>9</sup>

Looking at just the major UK and US organizations, there are already over two million registered members in nature-conservancy organizations.

<sup>7</sup> Ibid.

<sup>8</sup> Ibid.

<sup>9</sup> Ibid.



**Table 7: Population of Bird Watching and Conservation Groups in the US and UK (2013)**

United States		United Kingdom	
American Birding Association (ABA)	15,000	British Trust for Ornithology	40,000
Cornell Lab of Ornithology	200,000	Royal Society for the Protection of Birds	Greater than 1,000,000
National Audubon Society	600,000		
<b>Total</b>	<b>815,000</b>	<b>Total</b>	<b>1,040,000</b>

According to the statistical analysis prepared for the NMI's Tourism Master Plan, "it would take at least 572,000 visitors annually to adequately fill the number of operating hotel rooms at a sustainable level." Looking at the graph below, you can see where the sustainable level lies in the existing visitor trend.

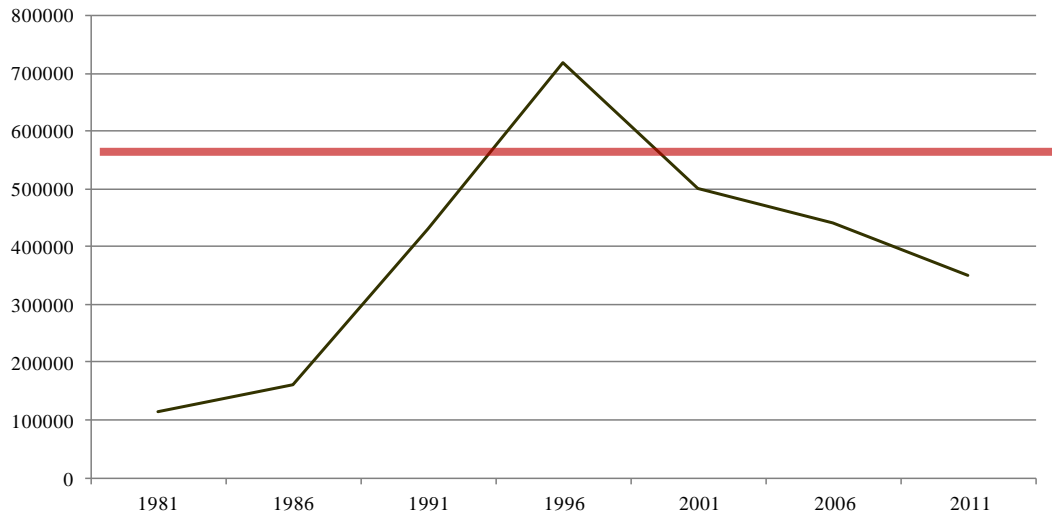

**Figure 5: Sustainability Level**

In other words, with the potential to brand Rota as a unique place for bird watchers to come and see the birds of the Mariana Islands, attracting no more than a quarter of

UK and US nature-conservancy group members is enough to maintain the tourism industry at a sustainable level. It is important to note here too that this number is even independent of the natural flow of tourists already traveling to the CNMI.

### Eco-Tourism

#### Concept and Current State

Nature-based tourism involves travel to destinations where the outdoor environment and cultural heritage are the primary attractions. It is used to help preserve nature and promote conservation through providing opportunities for visitors to engage with the environment. Popular attractions include wild fauna, wild flora, geological features, hydrological features, natural landscapes and natural seascapes, and participation in local activities. Eco-tourism primarily involves two forms of activity. First, one can passively observe the attraction for quiet enjoyment or learning. Second, one can actively immerse oneself in the natural setting for a more intimate adventure experience.

#### The Fastest Growing Niche Market

According to the United Nations World Tourism Organization, nature-based tourism, or "eco-tourism," is one of the fastest growing segments of tourism worldwide.<sup>10</sup> The chart below shows how there was a positive growth in all regions of the world except in the Middle East. A dramatic jump of international tourist arrivals to places like North Africa and Oceania where urban development falls

---

<sup>10</sup> *UN General Assembly: ecotourism key to eradicating poverty and protecting environment. (2013).*

behind indigenous landscape illustrates how the downturn of the economy has played a positive role in eco-tourism. In short, excluding North Africa, Oceania is experiencing the greatest increase in tourist growth rate in recent years.

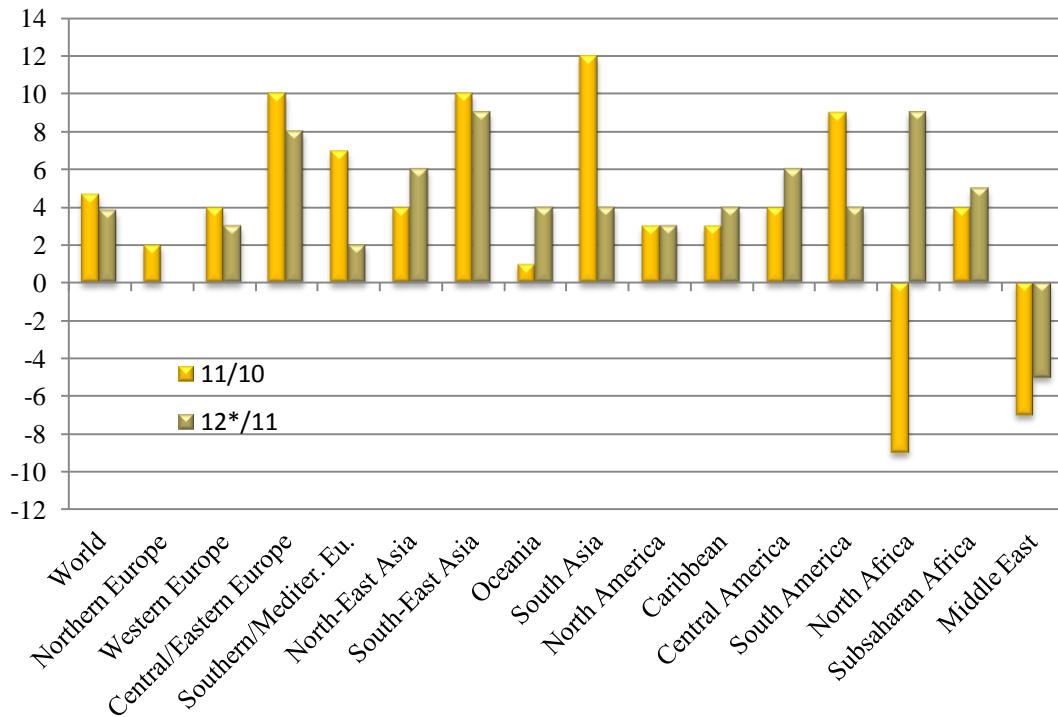

Figure 6: International Tourist Arrivals (% change over same period of the previous year).

#### Rota and Eco-Tourism

Because the Oceania region is experiencing the greatest increase in tourist growth rate in recent years, *now* is the right time to capitalize on tourism in the CNMI. As mentioned before, the NMI can target the bird watching population to help improve their economy. Rota would serve as the main eco-tourist attraction for this target population.

Again, since the majority of people in the bird watching market are more affluent individuals in their 50s and 60s and will be travelling from far, they are likely

to be long-stay travelers like many of the Russian visitors. The characteristics of this demographic as typically well-educated and pro-environmental protection also means that this particular group of visitors are more likely to support the greater effort for conservation and protection of the environment.

#### CNMI Conservation Practice

Although the greater goal for preservation of the environment is well known, little is known about how people actually work to achieve them. In the NMI, the belief that nature should be left alone in order to protect is the basis of their conservation practice. For at least the past ten years, efforts to preserve Rota's ecosystem and ecology have led to its isolation. The notion that isolation will guarantee protection has resulted in the near destruction of the local community, which is suffering from lack of tourism activity on the island.

## Chapter 2: Site



**Illustration 2: View of Songsong Village (Downtown area)**

### Rota

#### Why Rota

The last chapter establishes Rota as a good candidate for economic growth in the CNMI for a number of reasons that include:

1. Majority of tourists to the NMI want to see and experience the native environment and culture. Unlike Guam, Saipan and Tinian, Rota has remained relatively undeveloped due to its environmental conservation and ecological protection efforts.
2. Rota is the only island in the NMI that does not have snakes and therefore provides a safe place for visitors to explore the forests as well as serves as a sanctuary for the local avifauna population which has been in steep decline in the other islands.
3. Rota has the opportunity to establish itself internationally in the bird watching industry as a place where visitors can observe and learn from the efforts of avian/human architecture.

This chapter will highlight the physical characteristics of Rota and its existing bird sanctuary.

## Demographic and Environmental Facts

The island of Rota, or *Luta* in the native language of Chamorro, is a territory of the United States and governed under the Commonwealth of the Northern Mariana Island system. Located in the Pacific Ocean at 14°09'13"N 145°12'11"E, the island is part of a chain of islands known as the Mariana Islands archipelago in which Guam is the southernmost island. When excluding Guam, which is politically separate from the CNMI, Rota is referred to as the southernmost island of the Northern Mariana Island archipelago. The approximately 33 square mile island is twelve by five miles at its longest and widest. The 2012 census record shows that 2,527 people currently reside on the island, a 23% decrease from the last census in 2000 which was 3,283.

The CNMI is classified as having a tropical marine climate because it experiences an average of 83 degrees year-round temperature with between 79 to 86 percent humidity. There are only two seasons on the islands. The wet season lasts between July through October while the dry season lasts between November through June. Among the natural disasters that occur are typhoons (common), earthquakes (uncommon) and tsunamis (rare).

## Topography

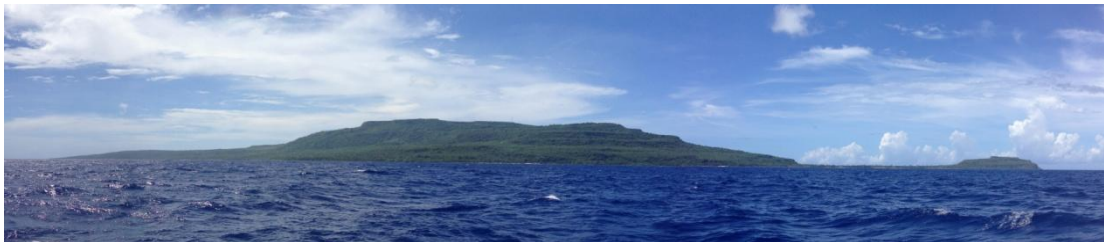

**Illustration 3: Panoramic of Rota Island Massing**

Rota is primarily an island of concentric limestone plateaus with the highest point found in the Sabana mountain region at 1625 feet above sea level. The lowest point is found in the Songsong Village area which sits on the isthmus connecting Mount Taipingot (also referred to as Wedding Cake Mountain) and the main landmass. There are steep, dissected areas in the Talakhaya area due to drainage from the mountain.

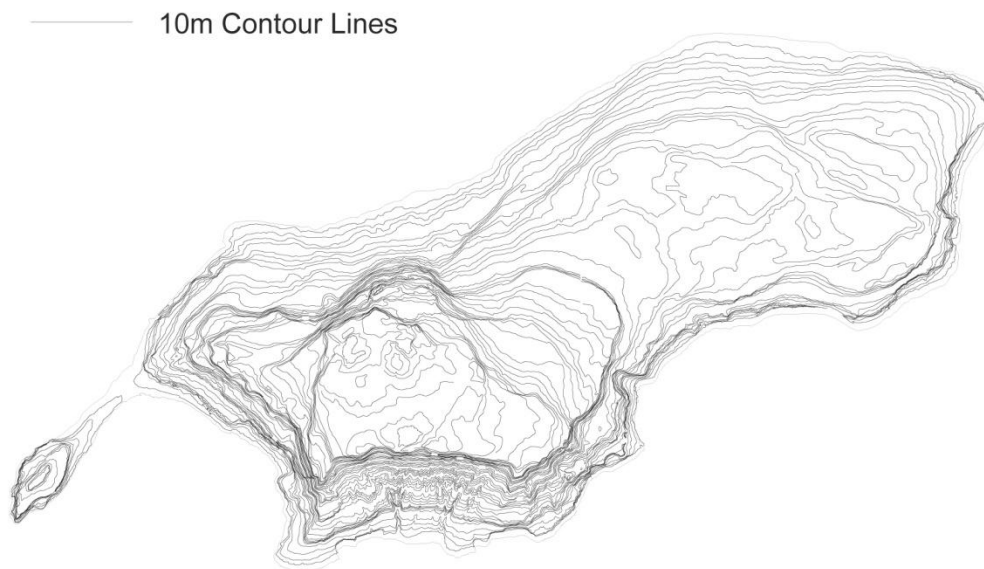

**Illustration 4: Topography drawing at 10 meter increments.<sup>11</sup>**

#### Roads

There is one main highway on Rota. It is an asphalted paved road that begins at the Rota International Airport on the eastern part of the island and ends at Songsong Village on the western part. The majority of the secondary connecting

---

<sup>11</sup> Information provided by the Rota Department of Public Lands.

paved roads in the villages are made up of compacted coral. Only Songsong and Sinapalo Village's secondary paths are made of asphalt.

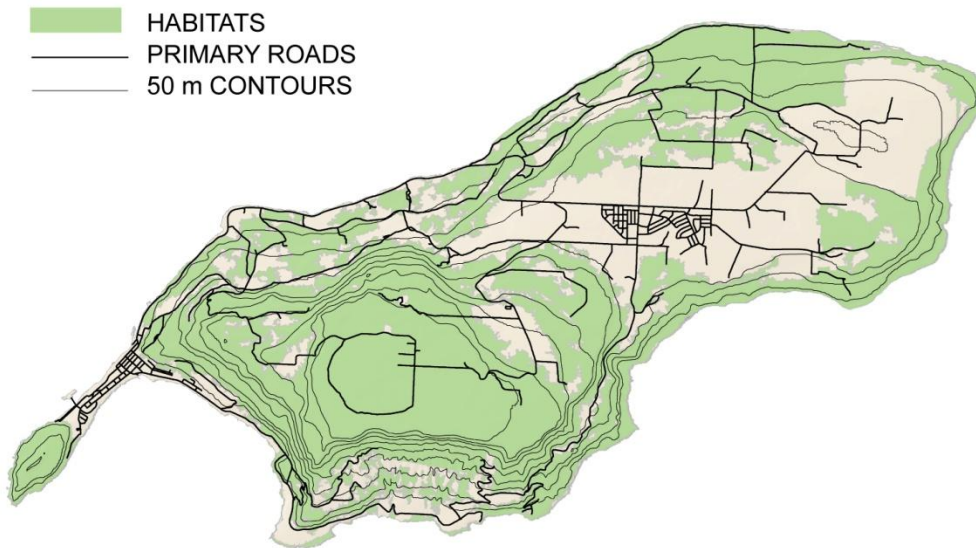

**Illustration 5: Roads, Topography at 50meter increments, Protected Habitats<sup>12</sup>**

#### Land Use

The majority of the island is protected under the federal government as strict ecological conservation areas. Second to this, agricultural homesteads take up most of the eastern part of the island. The Rota International Airport places third in terms of land coverage.

---

<sup>12</sup> Information provided by the Rota Department of Public Lands.



LEGEND:

-  LEASE (Long/Short term)
-  CNMI GOVERNMENT USAGE
-  PUBLIC LANDS (Encumbered/Unencumbered)
-  VILLAGE HOMESTEAD
-  AGRICULTURAL HMSTD.
-  PROPOSED VILLAGE HMSTD.
-  PROPOSED AGRICULTURAL HMSTD.
-  PRIVATE LOTS
-  CONSERVATION AREAS

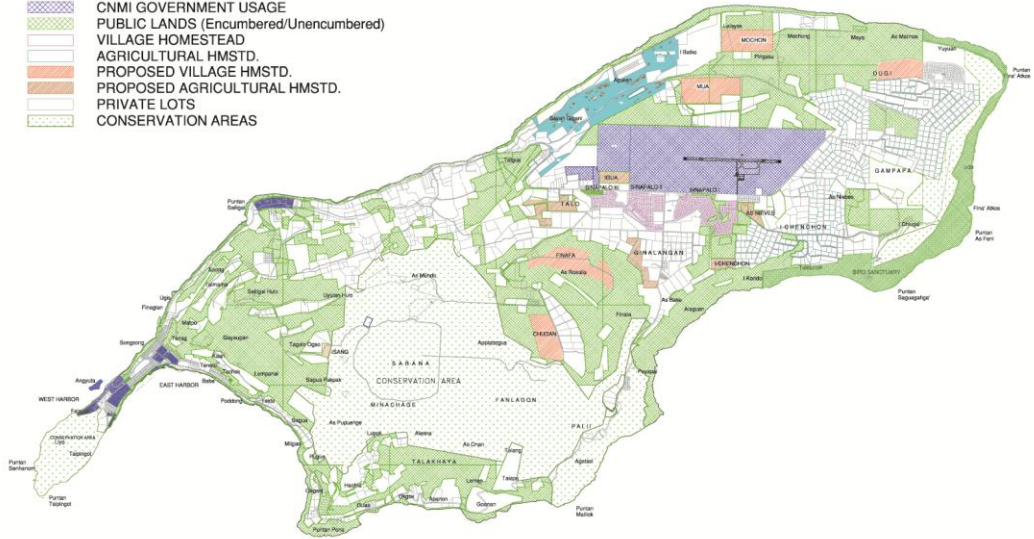





**Illustration 6: Land use map (2013)<sup>13</sup>**

### Critical Habitat

There are specific critical habitats under the general umbrella of conservation areas on the island. These habitats are homes of the critically endangered endemic birds –the Bridled White-Eye and the Mariana Crow. The island has also designated a large strip of land along the southeastern cliff side for the various seabird colonies that nest there. At the southern tip of the seabird nesting colony, there is a park area called I'Chenchon Park Bird Sanctuary which is intended to celebrate the seabirds that have chosen the island as their nesting grounds. This park serves as the site for the exploration of avian/human architecture, the results of which will provide the main nature attraction within the NMI islands.

<sup>13</sup> Information provided by the Rota Department of Public Lands.

LEGEND:

-  CONSERVATION AREAS
-  BIRD SANCTUARY
-  MARIA CROW CRITICAL HABITAT
-  BRIDLED WHITE EYE CRITICAL HABITAT

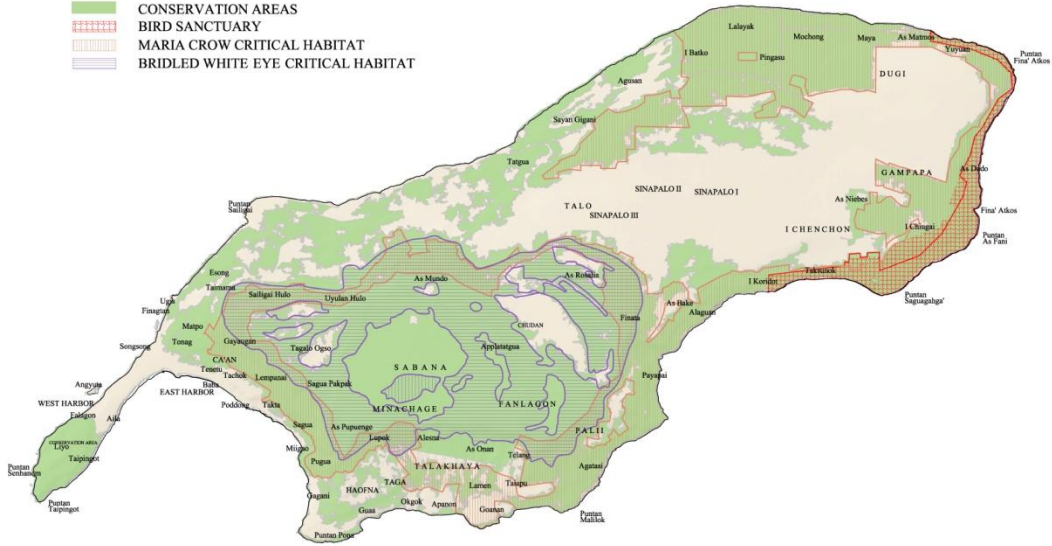

Illustration 7: Critical Avian Habitats and Conservation Areas<sup>14</sup>

*I'Chenchon Park Bird Sanctuary*



Illustration 8: Panoramic of Bird Sanctuary<sup>15</sup>

<sup>14</sup> Information provided by the Rota's Department of Public Lands.

<sup>15</sup> Peter Leong, "Welcome to Rota island!" Accessed 20 November 2013.

<http://www.flickr.com/photos/peteleongphotography/4101140217/sizes/z/in/photostream/>.

## History and Location

The local Fish and Wildlife department conceived Rota's I'Chenchon Park Bird Sanctuary as a public park where locals and tourists can observe the seabirds that nest at the site. As mentioned earlier, the park's land is part of a larger wildlife conservation area that has been designated by the US Fish and Wildlife Department to ensure the survival of endemic plant and animal species. It is through the joint effort of both groups that I'Chenchon Park exists today. The following sections discuss the different ways the site was studied for the purpose of the thesis.

## Human Perspective/ Existing Conditions



Illustration 9: Aerial View.<sup>16</sup>



Illustration 10: View from bottom terrace to main overlook.<sup>17</sup>

When visitors first come to the sanctuary, they come down a steep compacted road that leads to the sanctuary. Upon entering the site, they find an open clearing with a small concrete paved area (three cars maximum) designated for parking. Behind this lot, there is a restroom facility.

---

<sup>16</sup> SMV, "Bird Sanctuary." Accessed 20 November 2013. <http://imagesdesavions.com/rota/rota014.jpg>.

<sup>17</sup> Photo Credit Xavier Castro. Accessed 20 November 2013. [http://www.iluvsaipan.com/2010/11/i-luv-rota-too\\_17.html](http://www.iluvsaipan.com/2010/11/i-luv-rota-too_17.html).

To their left, there are native fruit trees. To their right, there is a large patch of coconuts which have been planted for visitor consumption. In front of them, beyond the large clearing of grass, there are flower trees which set the backdrop of a small welcome sign to the site.

Peeking out from the flower trees, there are two walking paths. These paths lead to the cliff side trail where you will find a couple of small lookouts and the terraced cliff side. The trail follows the edge of the terraces in order for visitors to easily observe the seabird nursery below.

Coming back up the trail, an offshoot from the path leads to a secondary, unpaved walking trail. This trail leads to another meadow with native forests to on one side and the same fruit trees that were seen at the entrance fruit trees on the other side. At one point, the meadow served as extra parking space when visitors were plentiful on the island. The grass here is now overgrown and reveals how long it has been since it was last used.

#### Avian Perspective

In thinking about avian/human architecture, it is important to consider the site from both perspectives. For birds, the sanctuary provides the proper combination elements necessary for a habitat in which they can thrive. First, the site provides food. As mentioned earlier, there are fruit and flower trees located at the center of the site. These fruit and flower trees not only provide food but also serves as the primary source of water for these birds.

Second, throughout the sanctuary, different specimens of trees ranging from five feet to over thirty feet tall provide a variety of shelter and nesting opportunities.

The site's natural cliff side also provides shelter and nesting opportunities in its crevices. Thirdly, the meadow at the site provides a safe place for birds to forage for materials and play with other birds. For seabirds, the cliff provides a strong updraft which they use to achieve long flying time while expending very little energy. This is an important activity that keeps seabirds healthy and able to endure long sea travel.

## Chapter 3: Avian Study

### Observing Birds

Tim Laman stated that it is "our human nature to explore places that we have never been to before," at the Birds of Paradise exhibition in Washington DC's National Geographic Museum on April 14, 2013. However, in the world of bird watching, it is tricky to observe birds in their natural environment since they are typically wary of humans. Because of this, it is necessary to gain a range of knowledge on the bird population you are dealing with before designing spaces and places that you intend for humans and avifauna to naturally interact with and observe each other.

This chapter discusses the people involved in avian research and protection programs on the island, the importance of birds in the greater context, and research compiled of Rota's avifauna.

## Institutions and Organizations



**Illustration 11: University of Washington's Rota Avian Behavioral Ecology Program Team: Intern, Phil Hannon, And Sarah Faegre (sitting from Left to Right).**

Academic

Currently there are two major universities studying the local avifauna on Rota. The first is the Cornell Lab of Ornithology who are studying endangered species and finding ways to save them. Kevin McGowan, an ornithologist who visited the island, documented that there are two birds on Rota found nowhere else in the world. These endemic birds are the Mariana Crow, or *Vorvus Kubaryi* (locally known as the Aga), and the Rota White-Eye, or *Zosterops rotensis* (locally known as the Nosa Luta). The other university presence on the island is the University of Washington's Avian Behavioral Ecology Program. This organization specializes in the Mariana Crow and has spent years tagging, documenting and researching this bird population. Their team is critical in the task of stabilizing populations of the Aga and other bird populations on the island.

## Government and other Organizations

Other organizations with interest in the Mariana Island avifauna include: Federal and Local Fish and Wildlife Department, Guam's Department of Agriculture Division of Aquatic and Wildlife Resources, and the California San Diego Zoo<sup>18</sup>. While the government's focus is to create policy, the zoo aids in fostering endangered species within their facilities.

### *The Importance of Birds*

#### Agents of Dispersal

Thanks to the increasing number of avian enthusiasts, we have learned that birds play a significant role in our ecosystem for a variety of reasons. First, they are agents of dispersal; meaning, they help transport things through the environment. For example, land birds allow for the diversity of plants through their natural eating habits. Sea birds perform a similar role with fish when fish eggs stick to their feet as they wade in the water. Pollination and cross-pollination are additional benefits birds naturally bring to our environment. These occur when they transport pollen on their beaks and feathers from one plant to another.

#### Insect Exterminators

In terms of their primary source of energy, most birds seek out adult and larvae insects which are high in protein. Birds benefit our human environment and agricultural ecosystem through their natural control over insect populations. In short, because most people dislike the presence of blood-sucking mosquitoes, crop-

---

<sup>18</sup> "Guam Rail." Accessed 20 November 2013. <http://www.aviary.org/animals/guam-rail>.



devastating beetles and creepy-crawly spiders, birds should be more appreciated in our society.

#### Bio-indicators

Finally, birds help us see potential threats to our own health and are, therefore, good bio-indicators. For instance, when the American robin population suddenly dropped in the 1950s and 1960s<sup>19</sup>, it was discovered that DDT, a chemical used to control the insect population which these birds were consuming, was also a huge danger to human health--especially since much of the chemicals were being absorbed by the crops we grew. Finally, the drop in bird populations to habitat loss informs society of the importance of environmental conservation as a whole.

### Primary Behaviors

#### Diet

Diet varies between species of birds. The majority of birds are omnivores—eating both plant and animal matter. Some are herbivores—eating seeds, fruits, buds, and flowers. Others are carnivores—eating insects, snails, fish, or carrion. The best way to determine the diet of a bird is through their bill shape.

#### Mating

Birds have five primary mating behaviors: feeding, preening, singing, dancing, and displaying. Depending on the species, the male attempts to attract a

---

<sup>19</sup> "The importance of Birds." Accessed 20 November 2013.  
[http://www.extension.iastate.edu/naturemapping/monitoring/Importance\\_Birds.htm](http://www.extension.iastate.edu/naturemapping/monitoring/Importance_Birds.htm).

female mate by carrying out one or a combination of these behaviors. Monogamy also depends on the species of bird.

### Nesting

There are a variety of ways birds nest. Depending on location, nesting materials also vary. In general, smaller birds construct more elaborate nests. This happens for a number of reasons. First, the smaller the bird, the lighter the nest materials. Therefore, more materials are used and more effort is necessary to weave, bind, adhere, etc. these small materials in order to construct the nest. Second, because smaller birds are much easier to prey on, they need a camouflage layer to deter predators. Third, because of their light weight, the wind can easily blow the nests away and, therefore, these birds need to exert more effort in securing their nest to a surface or branch structure.



**Illustration 12: Small bird nest construction.**

Medium bird nests, like small birds nests, consist of a layer of camouflage around the perimeter. Unlike small bird nests, however, they are constructed primarily of a latticework of twigs and sticks. Vines are used with leaves to hold the structure together while providing camouflage and individual leaves are added for

extra camouflage. Mud and waste matter is added as a usable surface for the eggs to sit on. Over time, it weighs down the nest to provide additional stability and security.



**Illustration 13: Medium bird nest construction.**

Large bird nests are the least complex in terms of having a system of construction. Since larger birds primarily nest at higher elevations, such as the top of a tree canopy, the birds expend less effort to camouflage their nests since ground predators are less likely to notice their presence. For the most part, large bird nests are constructed of a latticework of larger sticks with mud and waste material added over time.



**Illustration 14: Large bird nest construction.**

### Rota's Birds

Although there are hundreds of bird species on the island of Rota due to the presence of both migratory and introduced bird species, this project will highlight only native and endemic species as well as a handful of the seabird species which would be of particular interest to avian enthusiasts. In total, there are eighteen species

that have been studied for this project; the research has been summarized in the taxonomy sheet below.

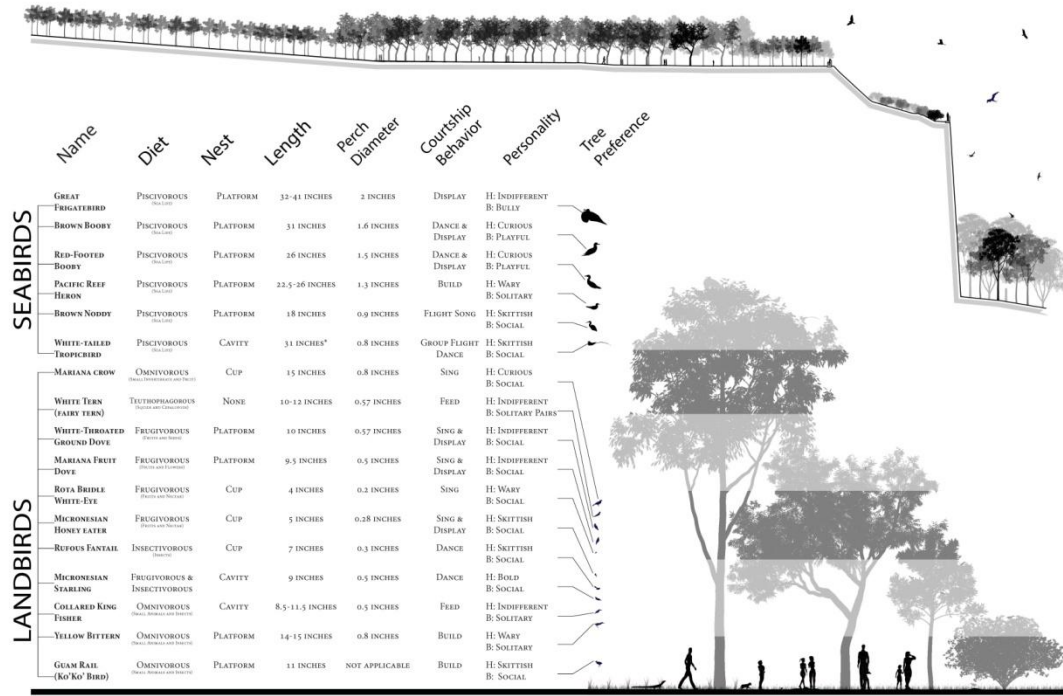

Illustration 15: Taxonomy sheet summarizing range avian study.<sup>20</sup>

The taxonomy summarizes a number of essential facts: classification (sea versus land bird), common name, diet, nest typology, size, ideal perch diameter, courtship behavior, personality (towards humans and other birds), tree and nesting elevation preference, and relation to human scale. The section drawing above also highlights the trees and their location at the bird sanctuary to help illustrate where on the site a person could find specific birds.

<sup>20</sup> Pratt, Bruner, & Berrett. (1987). *A Field Guide to The Birds of Hawaii and the Tropical Pacific*. New Jersey: Princeton University Press

It is important to note that the numbers documented for ideal perch diameter was formulated from information gathered from a study on bird housing accessories. Nesting, diet, length, courtship behaviors and personality are based primarily from the work A field guide to The Birds of Hawaii and the Tropical Pacific as well as from discussions with the local ornithologists and personal experience.

## Chapter 4: Precedent Study

In thinking about how to begin to design a place where both humans and birds coexist and learn from each other, a number of precedents were considered in order to visually highlight goals and values of the project.

### Path

#### Cornell Lab of Ornithology

The design of Cornell Lab of Ornithology, by RMJM, came about from the collaboration between the ornithologist and the architect. The two groups worked closely together to create a place where people can come to see birds while at the same time preserving the natural site. While some say that the highlight of the design is how the abstracted bird-like shape of the building allows for visitors to observe birds from many different parts of the building, the landscape design and nature trail actually achieve much better natural interaction opportunities for avian enthusiasts.



Illustration 16: Site Plan of Cornell Lab of Ornithology<sup>21</sup>

From the site plan, it is clear how the nature trails, developed by Boston landscape architect Susan Childs integrate into the wetland landscape. From the site plan, one can immediately see a variety of natural spaces in the landscape that provide different habitat zones for birds. For instance, there are small islands within the wetlands which are surrounded by denser forests. From the bird watcher perspective, the design is exciting because it provides variety of habitat zones which

---

<sup>21</sup> "Cornell Ornithology Laboratory/RMJM." Accessed 20 November 2013. <http://www.archdaily.com/19263/>.

means there is a higher chance to see a greater variety of bird species in that small area. It is the interaction of the trail with these habitat zones that allow people to not only see different types of birds but also how birds here use those different areas in the landscape.

### The Highline

Like the Cornell Lab of Ornithology, the Highline is successful in that the design segments a singular, monotonous path by creating a variety of spaces that cater to a wide range of people—from the solo explorer to groups of friends. The different strategies used to define places of stasis and movement include furniture arrangement, landscaping detail, and movement in the third dimension.



**Illustration 17: Lowered seating area from street view.**<sup>22</sup>



**Illustration 18: Lowered seating area interior view.**<sup>23</sup>



**Illustration 19: Entry Point.**<sup>24</sup>

In thinking about the path for the bird sanctuary, the nature trail is heavily influenced by these two precedents in that it integrates the path with different habitat zones and brings people to pause points by movement in the third dimension.

Material considerations for path detail are also taken into account to define different

<sup>22</sup> Iwan Baan, "High Line Park Photos," 2009. Accessed 20 November 2013.

<http://www.thehighline.org/galleries/images/high-line-park-photos>

<sup>23</sup> *ibid.*

<sup>24</sup> *ibid.*



habitat zones within the site. And finally, the dimension of the path was considered to control the flow of people within the site.

### Placement

Because of the nature of the project and location of site, the placement and scale of observatory structures needed exploration. Below you will find a compilation of observatory structures that express a variety of ways observatories can rest on a site. In general, the objective of looking at these different options was to study what type of structure or construction would provide the most positive impact (on avian habitat, human experience, environment, etc.) with the least disruption or intervention on the site.



**Illustration 20: Clingmans Dome, TN<sup>25</sup>**



**Illustration 21: Kielder Observatory, Northumberland, UK<sup>26</sup>**



**Illustration 22: Korkeasaari Island Lookout, Helsinki, Finland<sup>27</sup>**



**Illustration 23: An Turas Shelter, Northumberland, UK<sup>28</sup>**



**Illustration 24: Kiro San Observatory, Japan<sup>29</sup>**



**Illustration 25: Women at War Museum, Yorkshire, UK<sup>30</sup>**



**Illustration 26: Aurland Lookout, Aurland, Norway<sup>31</sup>**



**Illustration 27: Grand Canyon Skywalk, Skywalk, AZ<sup>32</sup>**



**Illustration 28: House on the Rock, WI<sup>33</sup>**

<sup>25</sup> Gary Wilson, "Frozen Clingmans Dome." Accessed 20 November 2013.

[http://www.smokiesinformation.org/blog/wp-content/uploads/394096\\_1015117724068673\\_1128551070\\_n.jpg](http://www.smokiesinformation.org/blog/wp-content/uploads/394096_1015117724068673_1128551070_n.jpg).

<sup>26</sup> "Kielder Observatory." Accessed 20 November 2013. [http://1.bp.blogspot.com/-Kghwan58lbM/TWQ4pa-FH-I/AAAAAAAAAI4/wFEa6ymtGa0/s1600/kielder\\_observatory\\_charlesbarclay130808\\_1.jpg](http://1.bp.blogspot.com/-Kghwan58lbM/TWQ4pa-FH-I/AAAAAAAAAI4/wFEa6ymtGa0/s1600/kielder_observatory_charlesbarclay130808_1.jpg).

<sup>27</sup> "Korkeasaari Island Lookout Tower Helsinki Tower." Accessed 20 November 2013.

<http://www.cumbu.com/wp-content/uploads/2011/04/Korkeasaari-Island-Lookout-Tower-Helsinki-Tower-image-3.jpg>.

<sup>28</sup> "An Turas Ferry Shelter." Accessed 20 November 2013. [http://officeinsight.org/wp-content/uploads/2013/03/539457519\\_8a6be7a475.jpg](http://officeinsight.org/wp-content/uploads/2013/03/539457519_8a6be7a475.jpg).

<sup>29</sup> "Kiro San Observatory." Accessed 20 November 2013.

[http://buildllc.files.wordpress.com/2008/10/kirosan\\_pushpullbar\\_com.jpg](http://buildllc.files.wordpress.com/2008/10/kirosan_pushpullbar_com.jpg).

<sup>30</sup> "Women at War Museum." Accessed 20 November 2013.

[http://static.dezeen.com/uploads/2010/07/dzn\\_Charlotte-Wilson-at-Free-Range-1.jpg](http://static.dezeen.com/uploads/2010/07/dzn_Charlotte-Wilson-at-Free-Range-1.jpg).

<sup>31</sup> "Aurland Lookout." Accessed 20 November 2013.

<http://www.notempire.com/images/uploads/aurland-2.jpg>.

Ignoring materiality in the observatories above, it is clear that some strategies for placement already require more intervention on the landscape than others. For instance, Kengo Kuma's observatory that cuts into the mountain required a huge amount of earth to be moved and held back in order to create the structure within the ground. Although, conceptually, this project is memorable to humans, an intention for this thesis is to learn to question how to mediate concept and conservation.

### Materials

Because of Rota's location, it is difficult and costly to import building materials such as large steel members and glass. Looking at most buildings on the island, there are two primary materials used for construction: concrete (unreinforced and reinforced) and wood. A tertiary material found on the island is steel which is mainly used to reinforce concrete.

#### Local Wood

Although the island has an abundance of trees, there are only two species of trees commonly used in building construction: the A'abang and Chopak trees. The A'abang wood is very hard and can be used for smaller design elements such as fencing, tables, chairs, frames, handrails, etc. The Chopak wood is both hard and very durable and is used for house beams and post, planks, stairs, and corner posts. In general, the locals practice conservation of these materials and only use wood from trees that have been cut down for farming purposes or are already dead in the forest.

---

<sup>32</sup> "Grand Canyon Skywalk." Accessed 20 November 2013. <http://www.journalofcommerce.com/images/archivesid/23982/100.jpg>

<sup>33</sup> "House on the Rock." Accessed 20 November 2013. [http://www.collectorsquest.com/blog/wp-content/uploads/infinity\\_ext\\_fs.jpg](http://www.collectorsquest.com/blog/wp-content/uploads/infinity_ext_fs.jpg)

## Bamboo

Because this material is plentiful around the island, comes in a variety of sizes and rapidly regenerates, bamboo will be used in this project. Today, the locals use the bamboo plant mainly as a structural framing material for furniture and small, temporary structures such as a beach hut or roadside vendor shack. In general, the compressive and tensile capabilities are not evident in the local architecture.

## Scale

In terms of scale, the observatories will be no more than two stories tall and, as much as possible, have minimum impact at the ground level. The two-story limitation for these structures comes from the fact that majority of the buildings on Rota are no more than a couple of stories tall. The small footprint relates to the overall goal of having the most positive impact with minimal construction.

## Chapter 5: Proposal

Every living species needs habitat in order to survive and thrive. Habitat is comprised of a proper combination of food, water, shelter and space. For the most part, human development has meant the destruction of habitat due to lack of consideration for the well-being of non-human species<sup>34</sup>. For this project, the local avifauna on the island of Rota are the subject of consideration and the primary goal of the thesis is to design structures that challenge the current notion that architecture destroys habitat.

### Path Study

Before discussing the design of the observatory structures, it is important to know that the location of each structure was strategically chosen based on a comprehensive study of the existing path and its relationship to the site.

#### Existing Path

The existing trail at the bird sanctuary clearly intends to bring visitors to the edge of the cliff where they can observe the seabirds. However, because there is also an abundance of land birds at this site, this thesis proposes to extend the existing paths to areas where people are likely to discover non-seabirds. The resulting path will serve as a nature trail that takes people into the different landscape/habitat

---

<sup>34</sup> Edwards, B. (2010). "Biodiversity: the new challenge for architecture." Royal Danish Academy of Fine Arts, School of Architecture.  
<http://www.thenbs.com/topics/Environment/articles/biodiversitynewchallengeforarchitecture.asp>

conditions found at the site (meadow, cliff, forest of different tree canopy heights, etc.) found within the site's property lines.

#### Strategies for Extension

There are three major strategies for extending the existing path and relating it to the different habitat zones. First, the path can hug the edges of the different zones with offshoots that bring humans into specific areas adjacent to the path. While the highlight of this scheme is that the path has very little impact on the actual areas where birds live or nest, it is counterintuitive to the goals for avian/human interaction.

Another strategy would be to have the new path move completely through the different zones. In this strategy, the strength is that people are completely enclosed within the area where birds live. However, having people always within the areas where the birds are may be too disruptive to the birds.

A final strategy explored was the simple extension of existing paths towards the edge of the property line. Each extended path was then connected to the nearest parallel path. Unlike the last two strategies, this strategy naturally moves people in and out of habitat zones.

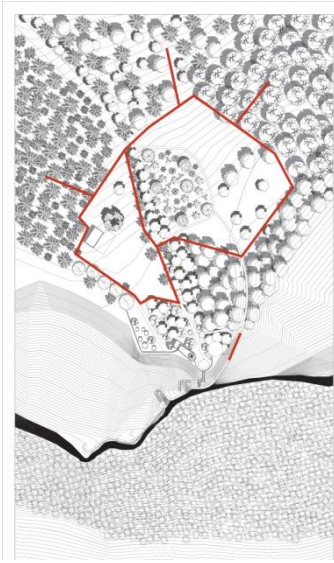

**Illustration 29: Edge**



**Illustration 30: Enclosed**



**Illustration 31: Extended**

Proposed

Although the idea of balancing the circulation of people in and out of where birds live was a good point in the last strategy discussed, there were some parts in that strategy that took people through areas that are not necessarily useful or safe. For instance, one extension takes you through an area of high vehicular traffic and another extension takes you right along where water settles after a good rain shower.









Therefore, in the proposed path for the site, the extended strategy is altered by taking away the issues just mentioned above. The result is a circuit-like nature trail that takes people in and out of the different habitat zones in a sensibly connected and loosely sequential manner. There are pause points along this trail intended to highlight the importance of that part of the site to birds.



Illustration 33: Proposed path overlaid on existing conditions with habitat zones

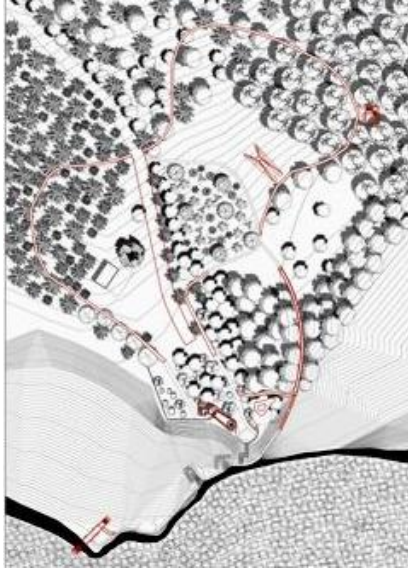

Illustration 32: Proposed path

	Food (Fruit Trees)	NESTING OPTIONS
	Water (Flower Nectar)	
	Extra Tall Trees (30' +)	
	Tall Trees (20'-30')	
	Medium Trees (10'-20')	
	Small Trees (5'-10')	
	Caves	
	Open Land for Forage and Play	
	Open Water for Forage and Play	

The following sections will describe each of the pause points in the sequence that most visitors would take. Each pause point exhibits how architecture can positively impact habitat in different ways—enhance, support, protect and unify. Secondary to this, each pause point promotes conservation through an education that is experientially gained rather than proscribed. Thirdly, each scheme expresses an appreciation for the local avifauna in a less literal and more phenomenological way.





**Illustration 34: Proposed Paths and Pause Points in Red**



**Illustration 36: Vine Plan**



**Illustration 37: Canopy Plan**



**Illustration 35: Burrow Plan**



**Illustration 38: Nest Plan**

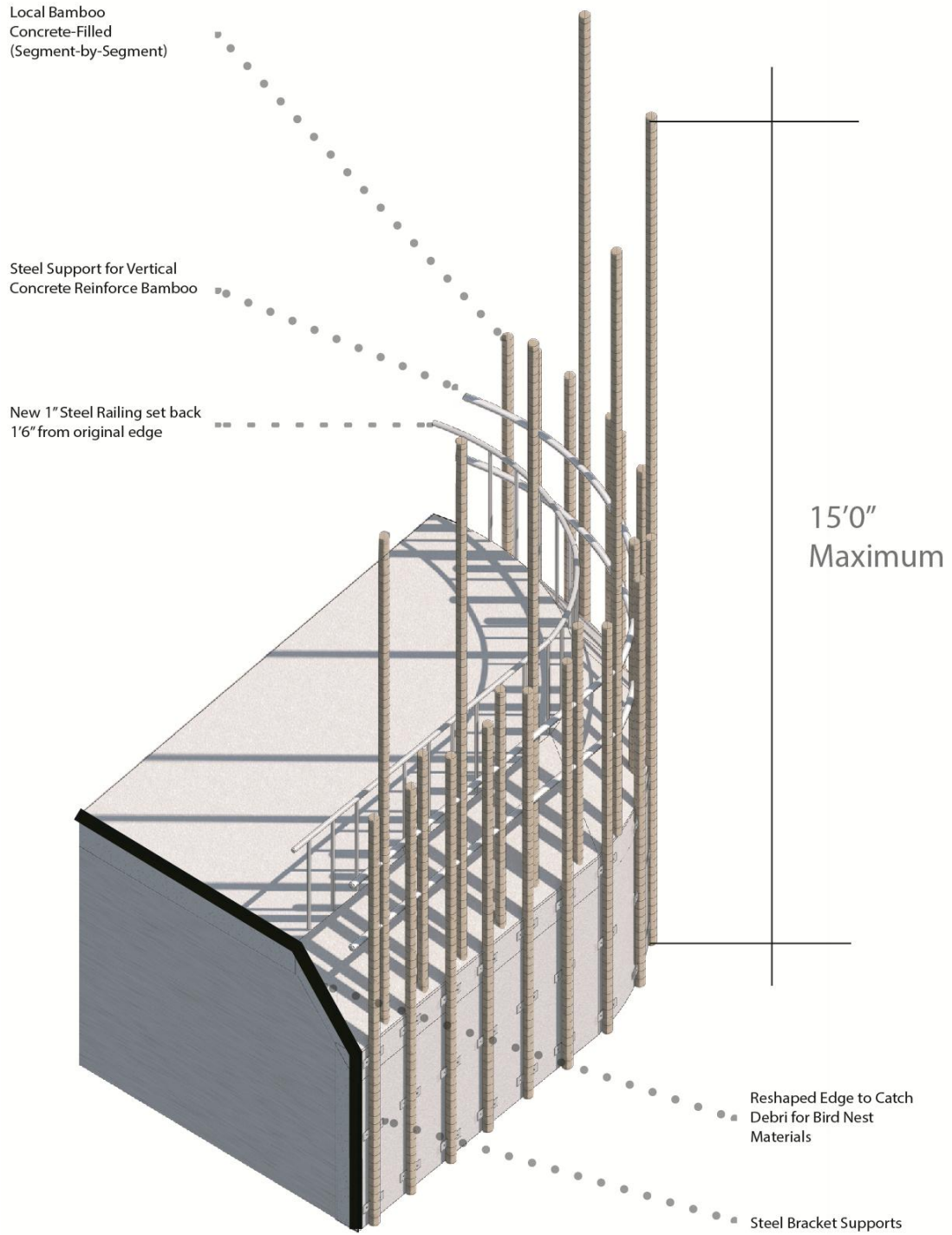

**Illustration 39: Cliff Plan**



**Illustration 40: Aerial Perspective with Proposal**

*Support: The Vine*



**Illustration 41: Vine Details**



**Illustration 42: Vine Perspective**



**Illustration 43: Vine Section**

### Purpose

When people enter the site, the first thing they will encounter is a path that takes you under a canopy of short flower trees. What they will likely do is collect the flowers that have fallen and then continue along until they come across the first pause point: The Vine. Sitting at the top of the cliff, this pause point uses an existing structure that has always served as the main observatory for the site. Today, a concrete umbrella structure is located at the center of the structure to provide shelter from the sun. Visually, it appears to cap off the cliff, which seems to rise from the ground below.

This thesis proposes to remove the concrete umbrella and alter the structure with features that heighten the cliff side and provide the same shading effect of the umbrella while at the same time supporting avian habitat.

#### Impact on avian habitat

As mentioned earlier in the section on nests, birds need certain materials to construct a nest; and, the smaller the bird the more the amount of material is required to well construct a nest. At the sanctuary, all the materials birds naturally use—sticks, twigs, vines, leaves and mud—are readily available. However, for smaller birds, vines are either difficult to get to (cliff side) or located in areas that make them easy targets for predators (ground and tree trunk). This scheme aims to address this issue by providing a place where vines can grow and smaller birds can safely collect them.

The design proposes to wrap the existing structure with rebars spaced at least eight inches apart and placed vertically along the outside concrete face. The area facing towards the ocean will have gaps greater than eight inches to provide unobstructed panoramic views of the site. The vine species that grow along the cliff side and are found in different areas of the site will be planted around the base of the structure and directed to grow up the rebars.

In terms of material choice, rebar was chosen because it is sturdy enough to resist wind force while also supporting vine growth. The diameter of the rebar also provides a comfortable perch for most small birds while they select pieces of vines for their nest. And finally, the rebar's long, linear characteristics are a natural defense against ground predators such as the monitor lizard and cat.

### Impact on humans

For humans, having the structure support a necessary material for the land birds at this site provides them a greater opportunity to encounter these birds. With the railing spaced at least an arm's length away from the rebar envelope, humans are at a great enough distance that neither species will feel threatened by the other's presence. Over time, when the vine material begins to fully cover the rebar envelope, the overlook will become shaded in the same way the concrete umbrella once shaded the space. Also, because plants produce a natural cooling affect on the environment, the space will not only be shaded but discernibly cooler in temperature. In terms of human participation at this location, visitors can assist birds by picking out the vines that have overgrown onto the railings and leave them for the birds to collect.

*Support: The Canopy*

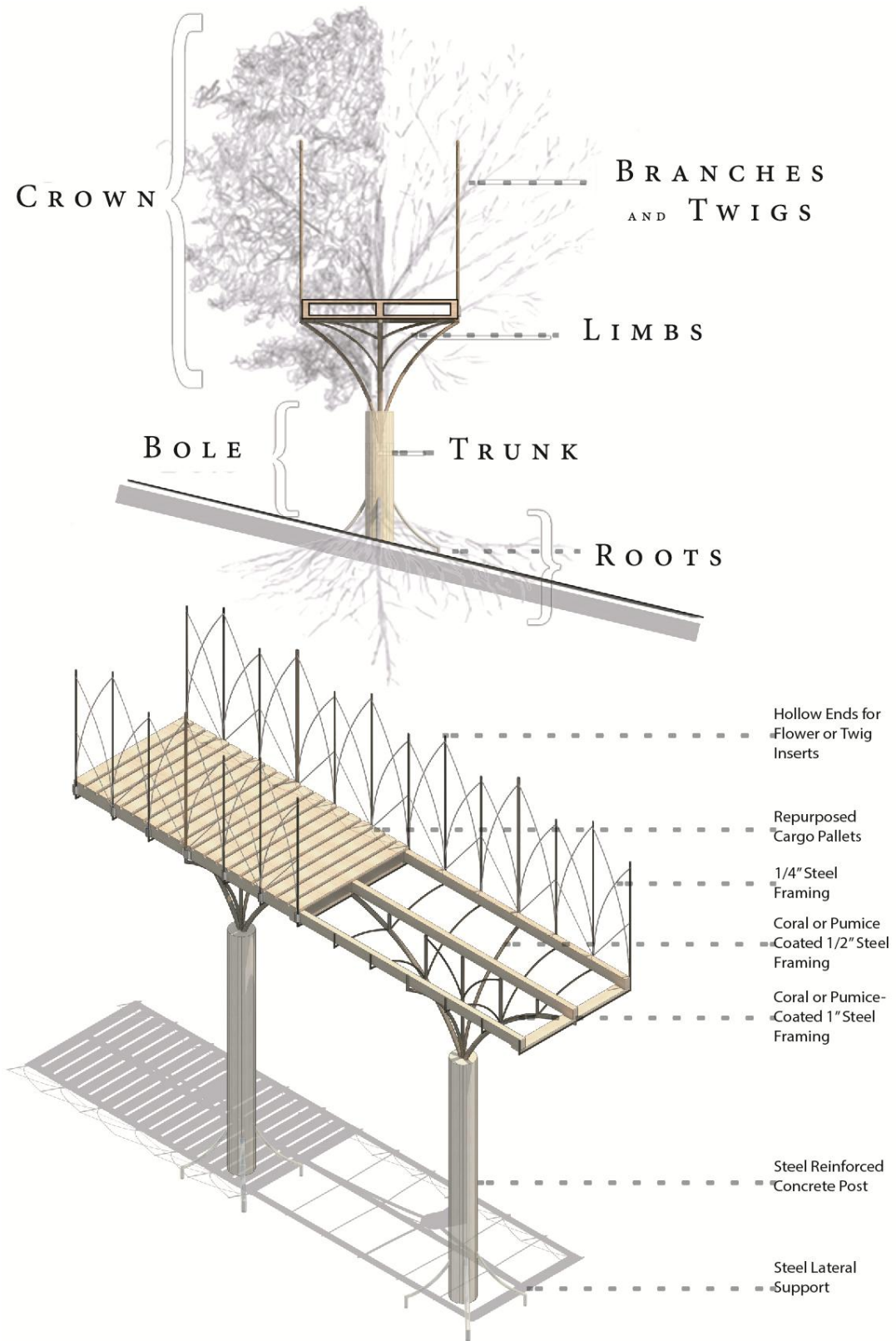

**Illustration 44: Canopy Details**

## Purpose

After the Vine, people will have a choice to either descend to the cliff side terraces which highlight the seabirds at the site or enter into the forest zone where they can observe the land birds. The trail that exists today takes you through a steep, rocky area beside the topmost terrace of the cliff side before having you enter the meadow at the site. Part of this trail is a path that connects to the seabird trail below. This trail is rarely used due to overgrown shrubbery and poor maintenance.

Because this part of the site is the only intersection between the land bird zone and the sea bird zone, this thesis proposes to improve the existing path with the design of a bridge that connects the two trails. This bridge will serve as an important point of entry and transition between the human and seabird zone into the land bird zone.



**Illustration 45: Goal of Canopy Scheme**





**Illustration 46: Canopy Perspective**

### Impact on avian habitat

Because the majority of the land birds at the site prefer the mid-story canopy level of trees, the bridge is designed to be at this elevation. Conceptually, the structure grows like a tree in that it starts with a single trunk and forks into smaller branches which become not only railings to protect humans from falling but also serve as additional perches for birds. Because of the branching structure of the bridge, different spatial conditions occur which provide the birds a variety of options for perching.

In a study on what keeps pet birds healthy, it is understood that, although birds have their preference for certain perch diameter sizes, it is important to provide multiple perch sizes to keep them agile and their grasping muscles strong. Perches of different materials such as coral or pumice stone are also useful for birds that sharpen their beaks and talons. Because of this, the design of the bridge structure consists of different sized members of different types of materials to promote healthy avian lifestyle needs.

The materials selected for the structure of the bridge include: concrete-filled bamboo, concrete-reinforced steel, steel rods, steel tension wire, and coral treated and untreated wood.

### Impact on humans

For humans, the bridge provides a unique transitional point in the landscape in that from either entrance—the seabird entrance and the main entrance—you begin at the ground level and suddenly find yourself at the mid-story of the tree canopy. At this level, the sounds of the birds—calling, singing, or warning—are more audible

and one immediately becomes aware of the presence of birds. Along the vertical support of the handrails, there are slots where one can insert fallen twigs that have littered the bridge. Visitors will be informed of the purpose of these slots and may take part in this activity. Over time, these inserted twigs will become additional perching options for birds while providing camouflage to the bridge.

Enhance: The Burrow

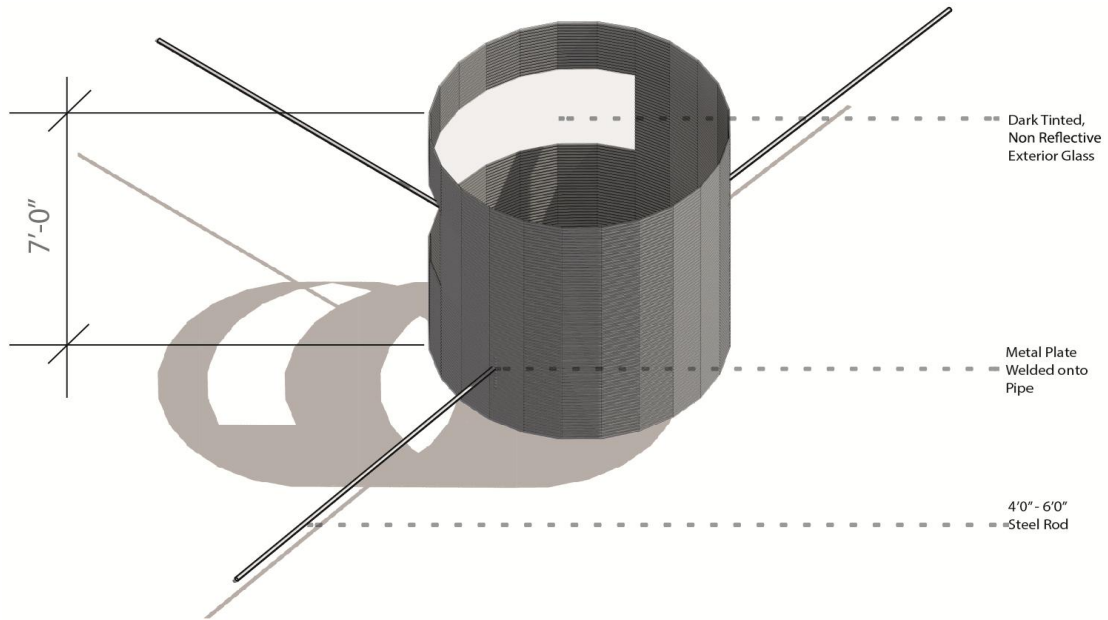

**Illustration 47: Burrow Section Perspective**

Purpose

After following the bridge, visitors will come across an open meadow. Unlike the forest ground, the meadow at the site provides a safe place for land birds to forage and play because it is light-filled and open. To provide people with an opportunity to closely observe the birds here, a burrow structure is planted into the ground. The

design of these burrow focuses on enhancing environment of the meadow so that birds are even more likely to use the space and have greater interaction with humans.



**Illustration 48: Burrow Steel Pipe Treatment**

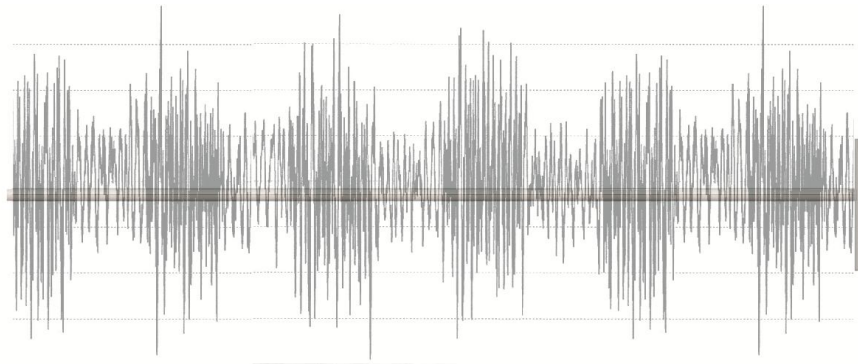

**Illustration 49: Steel Rod and Vibration Movement Diagram**

#### Impact on avian habitat

The mini burrows are located at the median between the nesting zone and fruit-tree area. The presence of mini burrows here provides a safer place for birds forage and play because they can first overlook the entire site before they fly to the

ground. These burrows also serve as a place for birds to rest between traveling from the nesting tree zone to the fruit tree zone or even just after playing.

Because the majority of birds eat worms for protein, the interior structure of the burrow is designed to attract worms to the surface. It uses the same principles of a worm harvesting technique called worm grunting. Humans are necessary in utilizing the burrow structure as a tool.

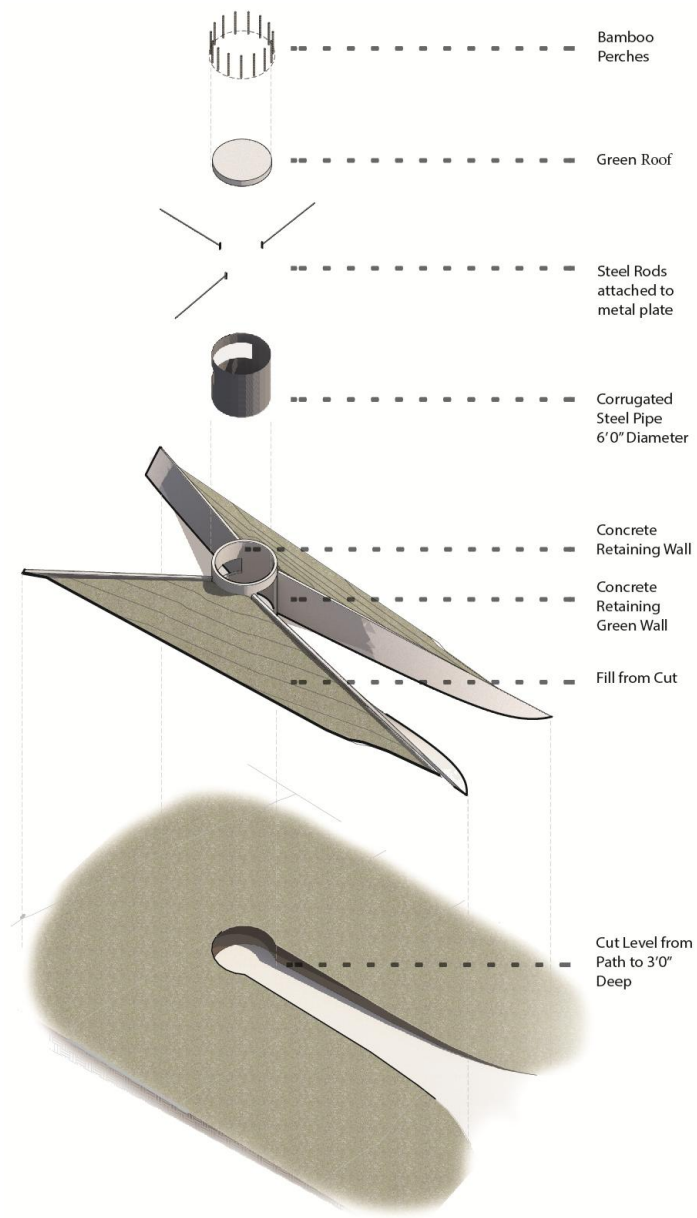

**Illustration 50: Burrow Construction Process**

### Impact on humans

For humans, the mini burrows provide a discreet place where they can closely observe the birds that forage and play in the meadow. To increase their chances for close encounters with the birds here, they can activate the burrow's worm grunting capability by rubbing the wall surface with a wooden stick. The vibrations from the surface of the wall transfer to the metal rods rooted in the ground and attract worms to the surface. Overtime, the goal of the burrow is to help birds positively associate the presence of humans at this particular part of the site.



**Illustration 51: Intention for Burrow Perspective**

Protect: The Nest

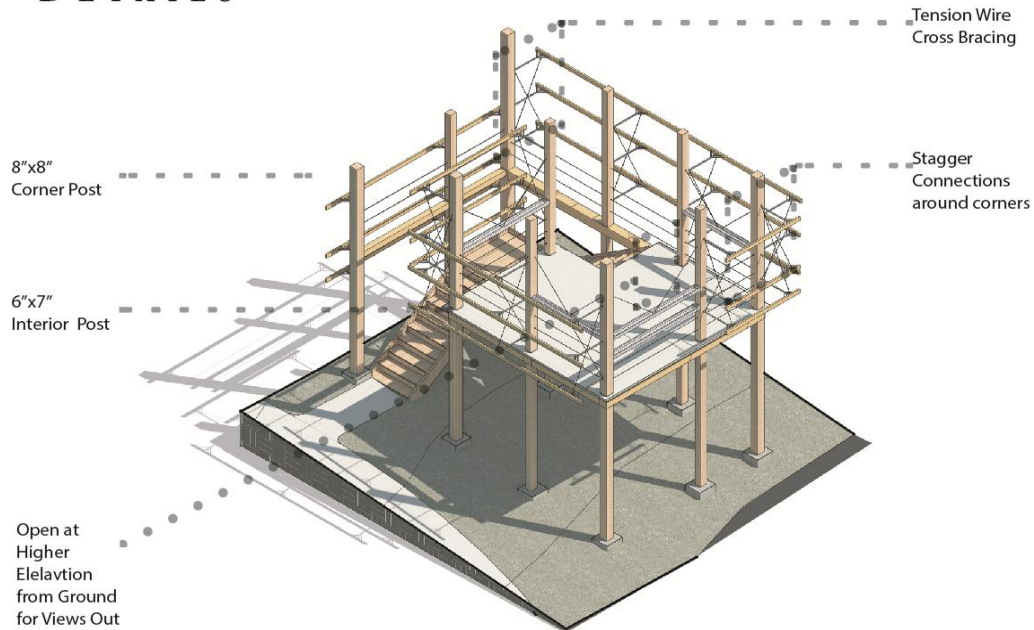

**Illustration 52: Nest Perspective**

Purpose

To the east of the meadow, there is a small patch of tall trees which are favored by birds that are currently under protection or are critically endangered. Due to the introduction of the monitor lizard and feral cats, the population of these birds has been in decline. Unlike most migratory and introduced birds on the island, the native avifauna are unfamiliar with the concept of predators. Although it is difficult to protect these birds in their daily life, design can provide a place where they can at least safely nest in the presence of these predators.

## STRUCTURAL DETAILS



**Illustration 53: Structural Details without Camouflage Layer**

### Impact on avian habitat

The structure of the observatory here parallels the way birds build their nests and introduces a new element—volume—as an element for deterring predators from where birds nest. Volume is created through the separation of the camouflage layer from the usable surface layer by thin steel rods of no more than an inch in diameter and three feet long. At the end of the rod that attaches to the camouflage layer, the rod forks into five branches which assist birds in securing their nests. While the three foot rod physically prevents monitor lizards from accessing the nests, the camouflage



envelope surrounding the entire structure deters feral cats by screening the nests.

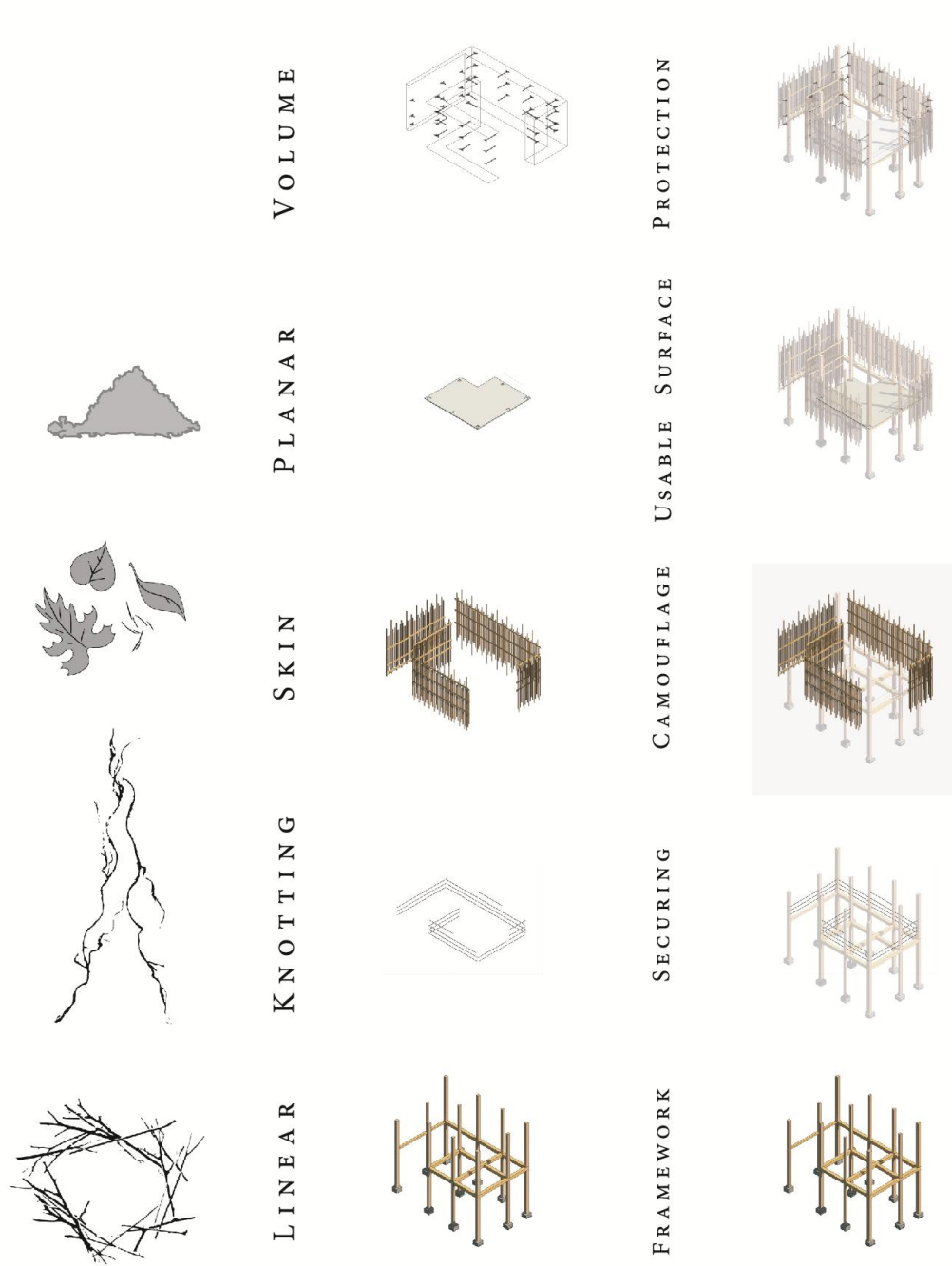

**Illustration 54: Metaphorical Parallel Construction**

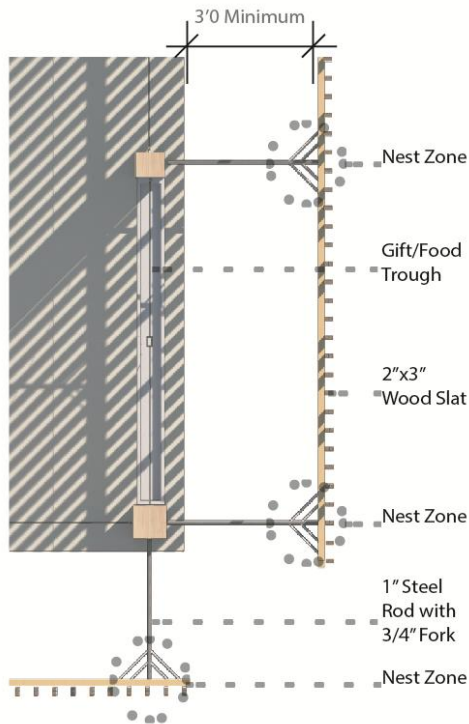

Illustration 55: Volume Detail

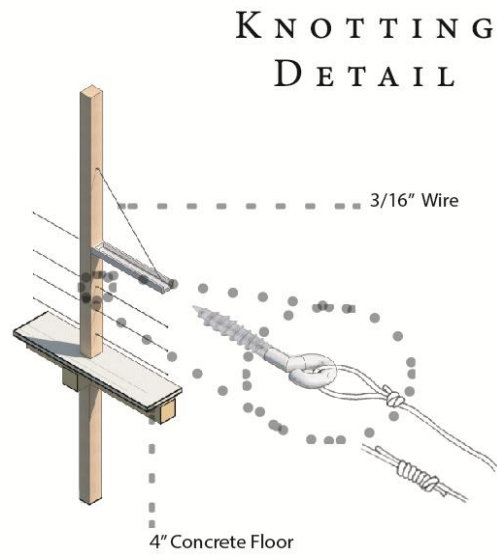

Illustration 56: Knotting Detail

### Impact on humans

Like the bridge, the structure is elevated above the ground to reach the mid-story canopy level where the birds here typically nest. Unlike the bridge, visitors are aware of their ascendance to the platform above. When they get to the top, they will see bird nests in the envelope of the structure which camouflages them in the environment. For those curious to physically touch the nests, they will be disappointed to see that it is beyond their reach for the bird's protection.

Over time, some friendlier birds such as the Mariana Fruit Dove and Ground Dove may perch on the rods that separate the camouflage layer from the platform. In this case, humans have to opportunity to more closely interact with them. Otherwise,

visitors would need to offer something of value—food, twigs, flowers, etc.—in order to attract them away from their nest. Along the handrail, there are places where people can place their gifts for these birds.



**Illustration 57: Intention of Nest Scheme**

*Unify: The Cliff*



**Illustration 58: Cliff Section Perspective**

Purpose

For those who chose to first explore the cliff side edge and not the land bird zone, they will immediately understand that from the cliff side beyond is the sea bird zone. The trail at the seabird zone runs along the edge of three terraces which span approximately sixty feet in elevation from the top of the site to the bottom terrace. The bottom terrace sits a little over one hundred feet above the base of the cliff.

Because most of the seabirds either nest at the top canopy of the trees below or in the crevices of the cliff, the interaction between humans and birds here takes place primarily along the trail. Unfortunately, the interaction that takes place along

the existing path falls short of what this thesis is about since the design of the trail essentially forces both species to remain in their zone. Therefore, this last structure attempts to blur the edge condition through a platform that unifies the edge in order to improve the interaction between humans and birds at this part of the site.

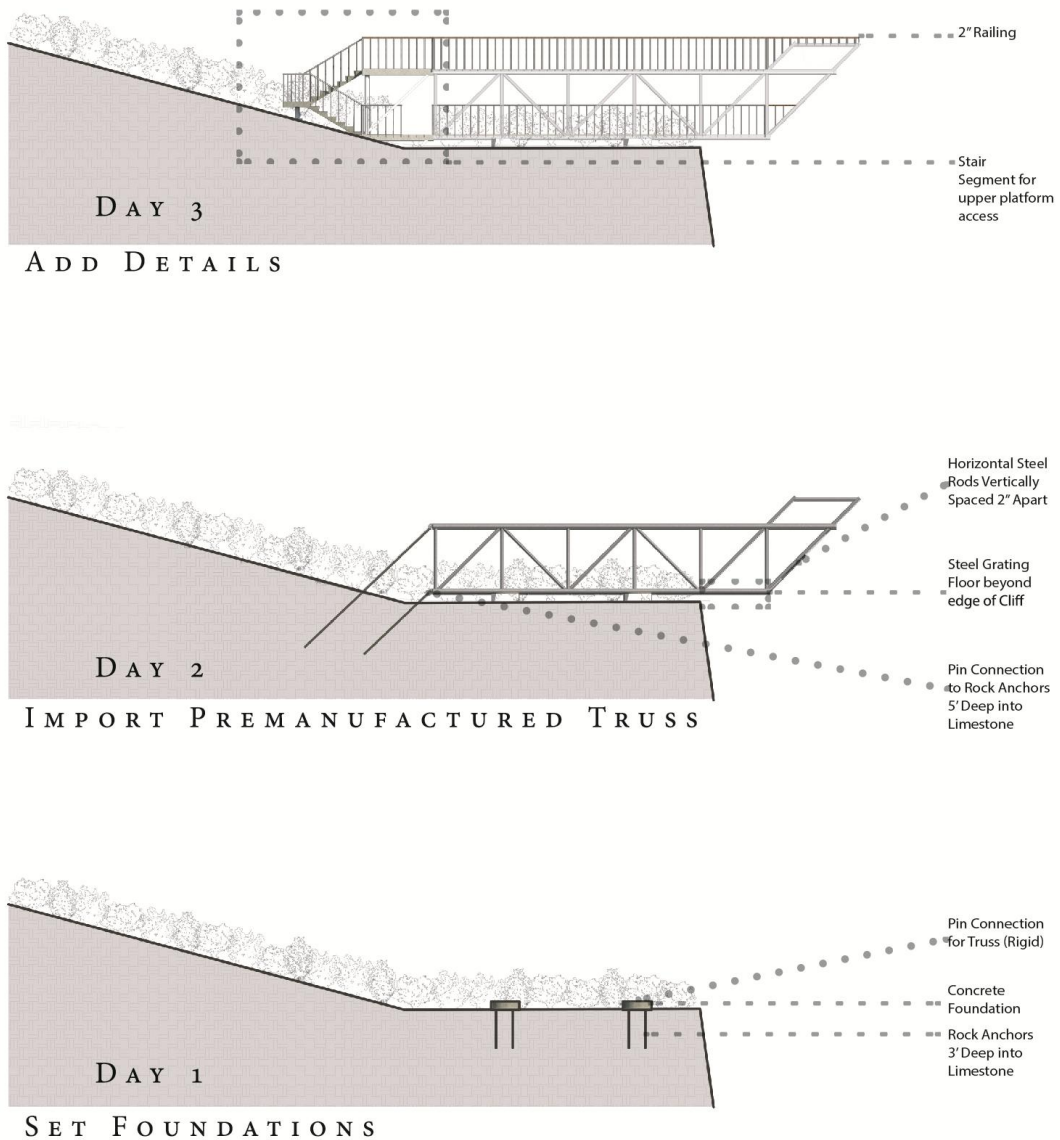
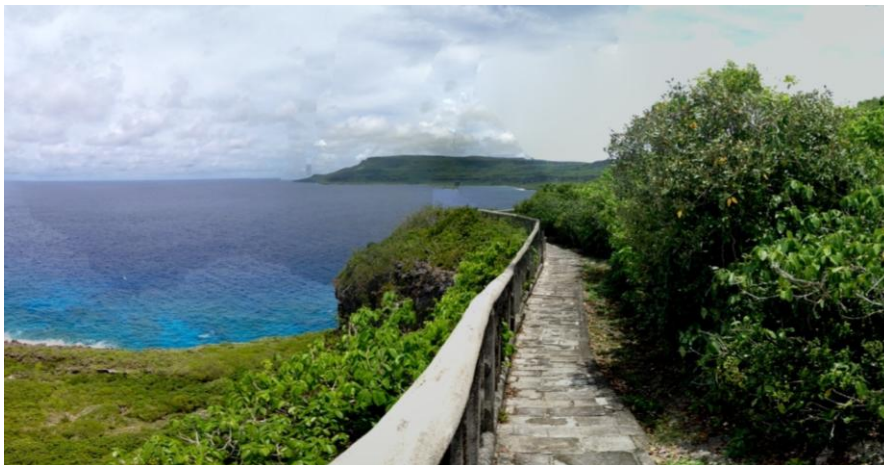

**Illustration 59: Construction Detail for Minimal Impact on Habitat**

### Impact on avian habitat

As mentioned earlier in the section on birds, the updraft winds created by the cliff side to help seabirds achieve long flight time while expending minimal energy. This kind of recreational activity helps these birds stretch and strengthen their wing muscles which keep them healthy enough to endure long sea travel.

For the most part, the seabirds here fly at an elevation almost parallel to the trail and, when humans are present, it is clear that these birds want to interact with them more closely. For instance, the red-footed booby and brown-booby birds express their curiosity by either hovering in front of or gently swooping upwards towards humans along the trail. A plausible reason for why these seabirds enjoy the presence of visitors is that they have associated humans with boats and other water vessels that are a welcome refuge for them at sea.



**Illustration 60: Typical cliff-edge path condition**

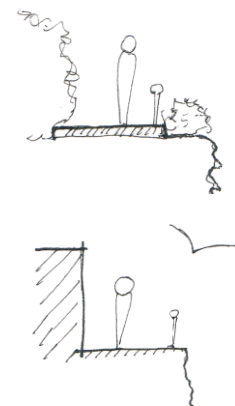

**Illustration 61: Bird Perspective**

Because the thick shrubbery behind the trail visually appears as something they could get entangled in, seabirds do not usually cross the boundary of the trail despite their clear interest in humans. The design therefore proposes the introduction

of platform at the bottom terrace of the site that elevates above the ground. The open surface of the platform will provide seabirds a place where they safely come into closer contact with humans.

#### Impact on humans



**Illustration 62: Typical Red and Brown Booby behavior outside of path.<sup>35</sup>**

This platform will extend beyond the cliff so that humans also have the opportunity to enter into the seabird zone. In this zone, humans will feel the upward draft that birds are using to fly. Additionally, they can unfold a mirror device to look back at the cliff side where smaller seabirds such as the Brown Noddy and White-tailed Tropicbird nest. Both these design decisions are intended to provide visitors

---

<sup>35</sup> Sarah Faegre, 2013. *Rota I'Chenchon Park Bird Sanctuary*

with the memorable experience and unique opportunity to have a greater appreciation for and understanding of the seabirds that live at this location.

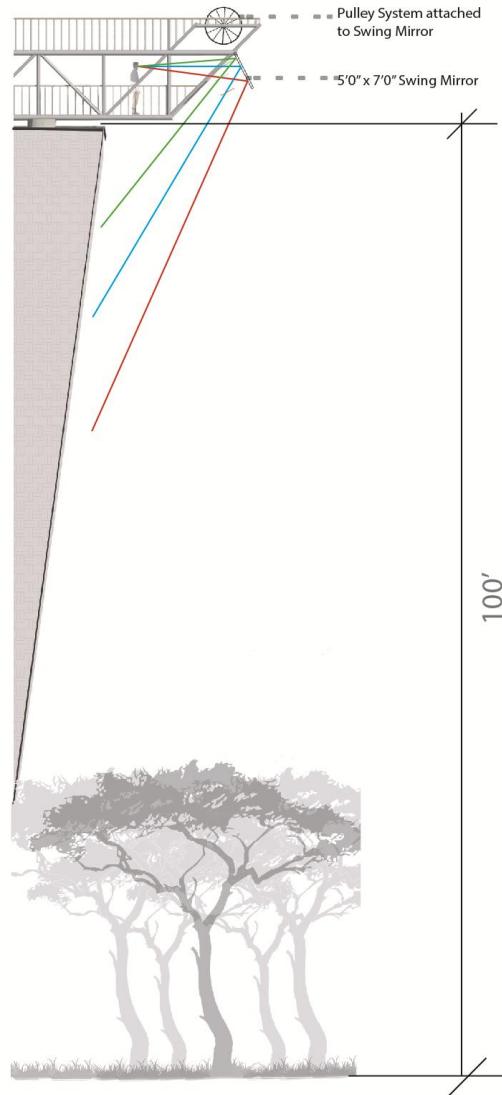

**Illustration 63: Mirror Device**





**Illustration 64: Perspective of Cliff Scheme from Top of Site**

## Chapter 6: Conclusion and Reflections

### *The Project*

Within the Northern Mariana Islands, the island of Rota serves as the best candidate for economic growth in that it provides the safest place for visitors to explore the native fauna and flora. Because of the island's dedication to eco-tourism and strict conservation efforts, the landscape remains relatively untouched with native forest covering majority of the land. Despite this fact, visitors find travel to Rota inconvenient due to the shortage of commercial flights to the island and therefore skip Rota in their tour of the Mariana Islands.

The shortage of commercial flight did not always exist and there is no established explanation for why the decision was made to cut flights to the island. However, it is my assumption that the accidental introduction of brown tree snakes to the other Mariana Islands—Guam, Saipan and Tinian—via air and sea transportation, is what led to the decision to cut transportation to Rota. Nevertheless, the lack of air and water transportation to Rota has negatively impacted the island so significantly that the population has drastically been declining and the economy has been struggling to survive.

In my opinion, the idea of shutting one's doors to a problem is not a good solution. Someway and somehow, the problem will find its way past the door and it is up to us to prepare for it. This project has explored a variety of ways to deal with the issue of loss of habitat due to human development and interruption of habitat due

to human introduction of foreign predators to the avian environment. It has illustrated how both humans and birds can benefit from design that carefully considers its users, the various issues associated with the problem (predators, climate, policy, etc.), and the overarching goals of the project.

Most importantly, although this thesis has proposed a solution to address a current issue on the island, the conceptual framework of the solution can be used to address more far reaching and alternative issues. For instance, what do we do when snakes finally make it to the island? According to this thesis, the solution would not be to annihilate the snake population; instead, we must learn how to create architecture that allows both species to share the habitat and, essentially, survive.

### *Final Reflections*

Looking back at the final review, I am very pleased that the jury was able to understand and welcome the concepts and goals behind my design despite my flawed structural details. I agreed with many of the comments that were made—even the comment “save the worms!” One of the comments-- it can be risky to “feed the animals”—struck me because I do understand that, by doing so, we alter a species’ reality and, more importantly, disturb the natural food chain. However, I do believe that this project is an exception—especially considering the fact that Rota may be the last island to save the birds of the Marianas.

In evaluating the way I managed my time, I wish I had spent less time thinking and more time doing. I believe in the necessity of model making in architecture and wish I had set aside more time to build at least three versions of each

scheme. To me, models help bring the idea to life and give people a chance to really be on the same wavelength. Nevertheless, I was happy to see that my earlier study models and site models were appreciated and, more importantly, helpful enough to get the ideas across.

Finally, despite the fact that none of the jury members realize that the majority of the site is not set up with accessibility paths, I still regret not immediately exploring how to provide accessibility on the site when I started the design process. Thinking about it now, I feel that it was a missed opportunity because accessibility paths tend to go longer planar distances and therefore have the potential to serve a greater positive impact on the environment if treated correctly. In the end, time got ahead of me and I unfortunately just could not figure out an appropriate way to create an accessible path that did not excessively disrupt the natural physical environment.

## Bibliography

2010-2011 Survey of US State of Tourism Office Budgets. US Travel Association, Washington DC. June 2011.

Birkhead, T. (2012). *Bird Sense: What It's Like to Be a Bird*. New York: Walker & Company.

Crossett, K., Clement, C., & Rohmann, S. (2008). *Demographic Baseline Report of U.S. Territories and Counties Adjacent to Coral Reef Habitats*. NOAA, National Ocean Service, Special Projects. Silver Spring, MD: NOAA.

*The Four Essential Elements of Habitat*. Retrieved 5 May 2013, from US Fish and Wildlife Services: <http://www.fws.gov/birds/documents/elementsofhabitat.pdf>

*Five Principles for Successful and Sustainable Heritage Tourism*. Cultural Heritage Tourism. Retrieved 17 Aug. 2011 National Trust for Historic Preservation: <http://www.preservationnation.org/information-center/economics-of-revitalization/heritage-tourism/basics/the-five-principles.html>.

*Global Trends Revealed at World Travel Market*. Global Travel Industry News, November 10, 2011.

Goodfellow, P. (2011). *Avian Architecture: How Birds Design, Engineer & Build*. Princeton, New Jersey: Princeton University Press.

Lynch, P., Proctor, N. (1993). *Manual of Ornithology: Avian Structure & Function*. Yale University. New Haven, CT: Yale University Press.

Management Analysis, Incorporated. (2012). *Nothern Mariana Islands Tourism Master Plan 2012-2016*. Marianas Visitors Authority. Vienna, VA: Management Analysis, Incorporated.

Podulka, S., Rohrbaugh, R. W., & Bonney, R. (Eds.). (2004). *Handbook of Bird Biology*. Ithaca, NY: Cornell Lab of Ornithology.

Pratt, Bruner, & Berrett. (1987). *A Field Guide to The Birds of Hawaii and the Tropical Pacific*. New Jersey: Princeton University Press

Proctor, N. S., & Lynch, P. J. (1993). *Manual of Ornithology: Avian Structure and Function..* New Haven: Yale University Press.

Reyes Planning and Consulting Firm. (2008). "Environmental Impact Assessment Report, Island of Rota Bird Sanctuary." Saipan, MP.

The National Aviary. (n.d.). *Guam Rail*. Retrieved 24 March 2013, from The National Aviary: <http://www.aviary.org/animals/guam-rail>

Unwin, M. (2011). *The Atlas of Birds*. Brighton: Myriad Editions.

UN World Tourism Organization. (2013, January 3). *UN General Assembly: ecotourism key to eradicating poverty and protecting environment*. Retrieved March 24, 2013, from World Tourism Organization UNWTO: <http://media.unwto.org/en/press-release/2013-01-03/un-general-assembly-ecotourism-key-eradicating-poverty-and-protecting-envir>

UN World Tourism Organization. (2013, January 29). *UNWTO World Tourism Barometer*. Retrieved March 24, 2013, from Tourism Trends and Marketing Strategies UNWTO: [http://dtxqt4w60xqpw.cloudfront.net/sites/all/files/pdf/unwto\\_fitur\\_2013\\_fin\\_2pp.pdf](http://dtxqt4w60xqpw.cloudfront.net/sites/all/files/pdf/unwto_fitur_2013_fin_2pp.pdf)  
Unwin, M. (2011). *The Atlas of Birds: Diversity, Behavior, and Conservation*. Princeton, New Jersey: Princeton University Press.

U.S. Geological Survey. (2005, July 26). *Brown Tree snake Colonization and Dispersal Events on Guam*. Retrieved March 24, 2013, from The Brown Treesnake on Guam: <http://www.fort.usgs.gov/resources/education/bts/invasion/colonize.asp>

*The Secret Life of Birds* (2012). [Motion Picture]. Mill Creek Entertainment.  
*What is Ecotourism?* The International Ecotourism Society-Uniting Conservation, Communities and Sustainable Travel-TIES. The International Ecotourism Society, Web. 1 April 2013. [www.ecotourism.org](http://www.ecotourism.org).

World Tourism Barometer, Volume 9, No. 1. World Tourism Organization (UNWTO). February 2011



