

## ABSTRACT

Title of Document: Down Syndrome Cell Adhesion Molecule, Dscam Molecular Diversity Crucial for Survival in *Drosophila Melanogaster*

Sangeetha Raghavan,  
Master of Science, 2009

Directed By: Dr. Leslie Pick  
Cell Biology and Molecular Genetics

There are 250,000 neurons and millions of synaptic connections in the fruit fly *Drosophila Melanogaster*. The molecular mechanism behind the precision and timing of these neural connections during development still eludes us. The *Drosophila* Down syndrome cell adhesion molecule or *Dscam* encodes 152,064 isoforms that are believed to be significant in regulating branching and targeting of neurites and, consequently in neuronal wiring and the viability of the organism. This study presents evidence that distinct set of *Dscam* isoform diversity is paramount to the survival of the organism. Single domain specific isoforms have been shown to rescue lethality caused by *Dscam* mutations up to the third instar larval stage (Wang, 2004). This study demonstrates that isoform specific single and multiple transgenes can rescue lethality caused by *Dscam* mutations up to the stage of adulthood with varying degrees of efficiency. The differences in rescuing abilities were found not only between isoforms belonging to different domains but also within the same domain. These individual differences reflect distinct functions for distinct isoforms in contributing to *Dscam*'s overall function.

Down Syndrome Cell Adhesion Molecule,  
Dscam Molecular Diversity Crucial for Survival  
In *Drosophila Melanogaster*

By

Sangeetha Raghavan

Thesis submitted to the Faculty of the Graduate School of the  
University of Maryland, College Park, in partial fulfillment  
of the requirements for the degree of  
Master of Science  
2009

Advisory Committee:

Dr. Leslie Pick

Dr. Jian Wang

Dr. Steven Brauth

© Copyright by  
Sangeetha Raghavan  
2009

## **Dedication**

This thesis is dedicated to my parents and husband who encouraged and supported me through different stages in my life, especially those trying times.

## **Acknowledgements**

I would like to thank my advisors Dr. Jian Wang and Dr. Leslie Pick for offering me continuous guidance and support for my project. I am grateful for Dr. Wang's patience in always being there to explain the nuances of the Dscam project. I am also thankful to Dr. Pick's valuable suggestions throughout my term as a graduate student.

I would also like to thank Dr. Steven Brauth for his suggestions on my thesis. I enjoyed attending your Neurobiology classes and I'm still fascinated by the things that I learned in your class. Thank you to Dr. Grunner for providing me with insights on data analysis and to Dr. Kenneth Frauwirth and Dr. Loiusa Wu for their useful comments.

I would like to thank the members of my lab – Cheng Peng, the hardest working person in the lab, always available and so very helpful, Jian-Hua Huang for enhancing my thesis with your contribution, Mohammad for the lively conversations and Siqian Feng for keeping the competitive spirit in the lab.

I would also like to thank the past members of the lab for their valuable contributions. Thank you Nicole Corrado for helping me with the initial data collection and maintenance of my flies. I would like to thank all the administrative personnel from Donna Brown to Sarah Biancardi for facilitating my graduation process.

Last but not the least I would like to thank my family, especially my son for being understanding and cheerful through all my ordeals and making me appreciative of life.

# TABLE OF CONTENTS

	<i>Page</i>
<b>Dedication</b> .....	ii
<b>Acknowledgements</b> .....	iii
<b>List of Tables</b> .....	v
<b>List of Figures</b> .....	vi
<b>Chapter 1. Introduction</b> .....	1
- Dscam and Down Syndrome.....	1
- The Significance of the Molecular Diversity of Dscam Extracellular and Transmembrane domain diversity of Dscam isoforms .....	3
- Cytoplasmic domain diversity and its implications.....	8
<b>Chapter 2. Experimental Methodology</b> .....	10
- Generation of Dscam Transgenes .....	10
- Development of genetically unique Dscam transgenic lines using P element Mobilization .....	13
- Genetic Rescue and Mutant characteristics .....	16
<b>Chapter 3. Results</b> .....	18
- Rescue of Dscam mutant using single and double copies of a single Dscam transgene with Transmembrane domain II or <i>TM2</i> .....	18
- Rescue of Dscam mutant using single copy of a single Dscam transgene with Transmembrane domain I or <i>TM1</i> .....	24
- Rescue of Dscam mutant using two different Dscam transgenes.....	27
- Rescue using different subsets of all three Dscam domains.....	32
<b>Chapter 4. Discussion</b> .....	35
<b>References</b> .....	46

# List of Tables

## Chapter 2: Research Methodology

Table 1: Identities of the Different <i>Dscam</i> Transgenic Lines .....	11
Table 2: Lines generated through p-element mobilization.....	12
Table 3: Lines used for Rescue – Part I, II and Part III.....	14
Table 4: Lines used for Rescue – Part IV.....	15
Table 5: Lines Used for Crosses between with Two Different Transgenes – Part III .....	15

## Chapter 3: Results Part I

Table 6: Rescue Using Single Copy of Transgene ( <i>TM2</i> ) – A2 Lines .....	22
Table 7: Rescue Using Single Copy of Transgene ( <i>TM2</i> ) – B2 Lines .....	22
Table 8: Rescue Using Single Copy of Transgene ( <i>TM2</i> ) – C2 Lines .....	22
Table 9: Rescue Rate with Double Copies of the Same Transgene ( <i>TM2</i> ) .....	23

## Chapter 3: Results Part II

Table 10: The Larval Count and the Survival Rate for Each of the <i>TM1</i> Lines .....	25
---	----

## Chapter 3: Results Part III

Table 11: Survival Rates of Lines with Two Different <i>Dscam</i> Transgenes .....	31
--	----

## Chapter 3: Results Part IV

Table 12: Survival Rates for the Single and Double <i>DspDs</i> transgenic lines during the Three Stages of Development .....	34
---	----

# List of Figures

## Chapter 1: Introduction

Figure 1: Human and Drosophila Dscam Molecular Architecture .....	2
Figure 2: Drosophila <i>Dscam</i> Amino Acid Sequence .....	4
Figure 3: Drosophila <i>Dscam</i> potentially encodes 152,064 distinct isoforms .....	9

## Chapter 2: Research Methodology

Figure 4: Schematic of Dscam Transgenic Lines and Scheme of Crosses .....	17
---	----

## Chapter 3: Results Part I

Figure 5: Survival Rate Comparison for <i>TM2</i> Lines .....	21
Figure 6: Survival Rate Comparison for <i>TM2</i> Lines at Larval Stage .....	21
Figure 7: Survival Rate Comparison for <i>TM2</i> Lines at Pupal Stage .....	21
Figure 8: Survival Rate Comparison for <i>TM2</i> Lines at Adult Stage .....	21
Figure 9: Comparison of Survival Rates Between Single & Double Transgenes.....	23

## Chapter 3: Results Part II

Figure 10: Comparison of the Survival Rate for the <i>TM1</i> Containing Lines .....	26
Figure 11: Comparison of the Mean Survival Rates of the <i>TM1</i> and <i>TM2</i> Lines .....	26

## Chapter 3: Results Part III

Figure 12: Rescue Using Two Different Transgenes (A2 -17 x B2 and C2) .....	29
Figure 13: Rescue Using Two Different Transgenes (A2 -26.1 x B2 and C2) .....	30
Figure 14: Rescue Using Two Different Transgenes (B2 x C2) .....	30

## Chapter 3: Results Part IV

Figure 15: Comparison of Survival Rates of <i>DspDs</i> Lines (with single copy).....	33
Figure 16: Comparison of Survival Rate of Single & Double copy <i>DspDs</i> lines .....	34

## **Chapter 1: Introduction**

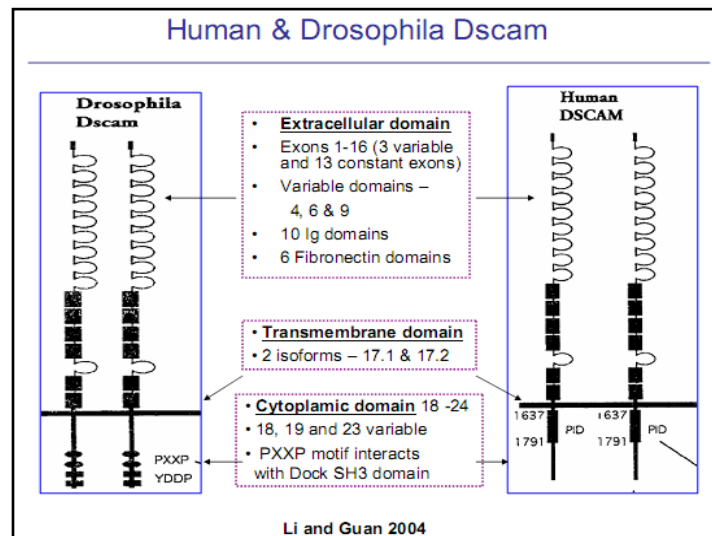
### **Dscam and Down Syndrome**

Down syndrome is a developmental disorder caused by trisomy 21 in human beings. It is one of the most frequent genetic disorders contributing to mental retardation in 1 in 800 live births in all races and economic groups (Fryns et al., 1984). Human Down syndrome cell adhesion molecule or DSCAM first identified by Yamakawa et al (1998) was mapped to a region known as the Down syndrome critical region DSCR in chromosome 21. DSCAM was found to be one of the genes associated with the Congenital Heart Disorder which was commonly found in 40%-60% of Down syndrome patients suffering (Barlow (a), 2001; Wells, 1994; Yang, 2002). A recent finding that human Dscam is not only expressed in the nervous system but also the circulatory system may suggest that it may play a role in Congenital Heart Disorder (Baumann, 2007).

Humans have two Dscam paralogs – Human DSCAM present on the 21<sup>st</sup> chromosome and Human DSCAM like 1 present on chromosome 11. They share about 64% amino acid similarity in the extracellular domain (Agarwala (b), 2001). The human Dscam gene is about 840kb long compared to the one in *Drosophila* which is about 60kb in length. Both human homologs appear to produce limited alternative variants (exons 3 and 4), unlike their insect counterparts (Gravelly, 2004). Tissue in situ hybridization using human and mouse DSCAM and DSCAML1 probes showed inverse ventral-dorsal expression patterns of the two paralogs in the mouse embryonic spinal cord and the developing cortex. DSCAM and DSCAML1 were also found to be expressed in

embryonic and adult mouse brain tissues – cortex, cerebellum, hippocampus, olfactory bulbs, choroid plexus, root and floor plate of the fourth ventricle, pons, medulla oblongata, eye, limb buds and dorsal root of ganglion (Barlow (b), Barlow (c), 2002; Agarwala (c), 2001).

**Figure1: Human and Drosophila Dscam Molecular Architecture**



**Figure 1:** A schematic of the molecular structures of Human and Drosophila Dscam molecules comparing the three domains: extracellular, transmembrane and cytoplasmic domains (Source: Li, Guan et al 2004). The extracellular domain shares many similarities between both molecules in terms of the same number of Ig and Fibronectin domains. There is not much similarity between the transmembrane and cytoplasmic domains with Human Dscam having motifs that directly interact with the p21-activated kinase or pak while Drosophila Dscam interacts with pak indirectly through the adaptor molecule Dock.

Human and Drosophila DSCAMs have three domains: the extracellular transmembrane and the cytoplasmic domains (Figure 1). Both molecules share similar molecular architecture in terms of the number and organization of the Ig and fibronectin domains in the extracellular domain. They share 32% sequence identity and 49% sequence similarity in the extracellular domain. The transmembrane and cytoplasmic domains do not share many common elements. The cytoplasmic domains in

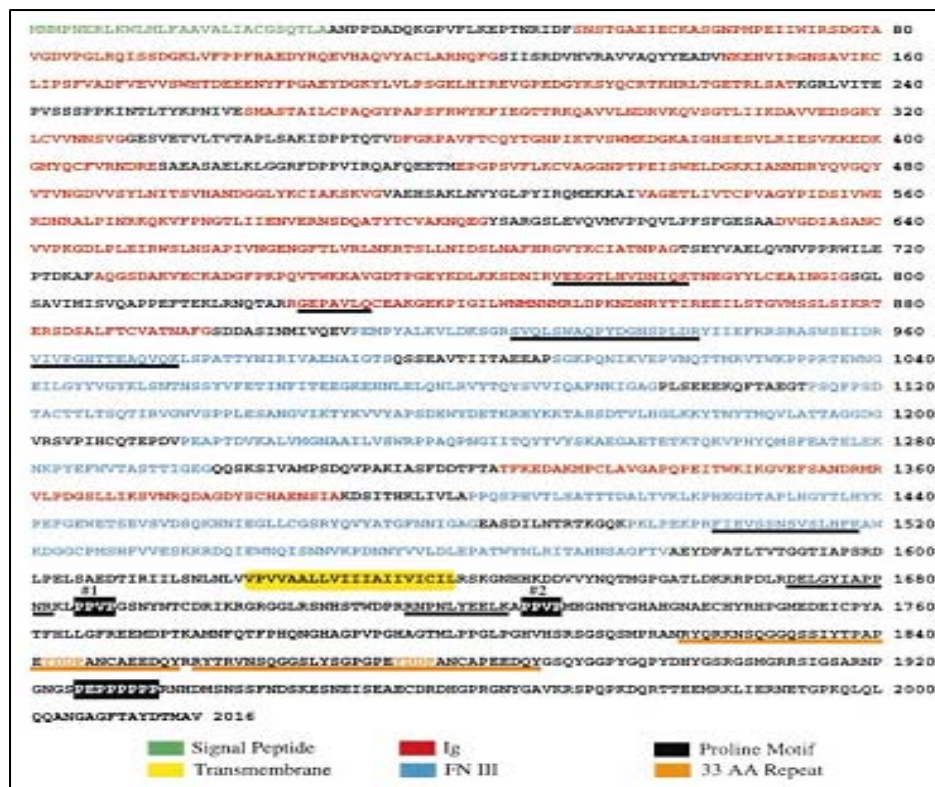
both molecules are predicted to interact with different signaling molecules. *In vitro* studies have shown Human DSCAM to directly interact with Pak (p-21 activate kinase) via the Pak-interacting Domain (PID) in the cytoplasmic domain (Li, 2004). In contrast the *Drosophila* DSCAM indirectly interacts with Pak through an adaptor molecule Dock (homolog of human Nck).

### **The Significance of the Molecular Diversity of Dscam Extracellular and Transmembrane domain diversity of Dscam isoforms**

*Drosophila* DSCAM was identified as a tyrosine phosphorylated 270kDa protein that interacted with the adaptor protein Dock in an *in vitro* immunoprecipitation and purification assay (*Figure 2*, Schmucker, 2000). Comprehensive cDNA analyses revealed multiple mutually exclusive isoforms generated through alternative splicing (Schmucker, 2000; Gravely, 2005). *Drosophila* DSCAM is composed of three domains the extracellular (with 10 Ig and 6 Fibronectin domains), the transmembrane and cytoplasmic domains. Each domain has variable exons (3 in the extracellular, 1 in transmembrane and 2 in the cytoplasmic domain) that contribute to the plethora of *Dscam* variants. One of the structural bases for mutually exclusive splice variants may be the formation of secondary RNA structures called istem or inclusion stem during exon4 variant formation (Kreahling, 2005). It is believed that given *Dscam*'s multiple exons, the choice of alternative exon at one cluster modulates the choice at adjacent clusters (Neves, 2004; Kreahling, 2005). The splicing mechanism does not necessarily provide insight into the biased manner in which the exon subsets are chosen. There is however some unknown

incentive for regions of the *Dscam* gene that have been conserved. To determine if alternative splicing in *Dscam* extends to other organisms, sixteen genomes were iteratively searched for homologs using four of *Drosophila Dscam*'s alternatively spliced exons (4, 6, 9 and 17). Homologs found in nematodes, arthropods and vertebrate genomes were arranged in tandem arrays which indicated mutually exclusive splicing (Crayton, 2006). The splicing mechanism thus could potentially be significant in regulating the choice of alternative exons.

**Figure 2 –*Drosophila Dscam* Amino Acid Sequence**



*Figure 2* is the amino acid sequence for p270 or *Dscam* which is a single pass transmembrane protein containing multiple domains. The domains are color-coded as indicated. The underlined amino acid sequences were the ones obtained for the p270 tryptic peptides. Two 33 amino acid direct repeats each contain a single Dock SH2-domain consensus binding site (YDDP). The PXXP motifs are numbered. (Adapted from Schmucker et al 2000).

For *Drosophila* DSCAM the three Ig domains 2, 3 and 7 contribute to variation in the extracellular domain encoded by exons 4, 6 and 9 respectively (Schmucker, 2000). X-ray crystal structures of the N-terminals of the first four Ig domains show a horse shoe like configuration with variable domains 2 and 3 engaged in homo-dimerization and anti-parallel pairing (Meijers, 2007). Amino acid sequence similarity between isoforms generated by the three extracellular exons (4 – 33-81%, 6 – 22-87% and 9 – 23-92%) ranged from anywhere between 22-92% (Schmucker, 2000). In all there are 38,016 isoforms; 19,008 from the extracellular and 2 from the transmembrane domains (encoded by exon17) that have been reported so far. The comparison of Dscam alternative splicing among other similar insects belonging to *Drosophila* subgenus (*D.melanogaster*, *D.pseudoobscura*, and *D. virilis*), the mosquito *Anopheles gambiae*, and the honeybee *Apis mellifera* revealed that alternative variants within one species are much more closely related than those within the other species or insects (Gravelly, 2004). This suggests that individual species may have undergone gene duplication but still retained the capacity to generate abundant isoforms crucial for the formation and maintenance of neuronal wiring.

*In vitro* experiments indicated that the variable extracellular domain isoforms engage in isoform-specific homophilic binding (Wojtowicz, 2004 and 2007; Hughes, 2007). Evidence for this came from *in vitro* cell adhesion assays with specific *Dscam* extracellular domain isoform-expressing culture cells and, high-throughput ELISA assay that tested relative interaction between similar and dissimilar extracellular isoforms. These assays demonstrated that variable isoforms with 100% amino acid sequence

similarity bound to each other and reduction in the amino acid similarity reduced or abolished binding. Heterophilic binding was rarely observed. The transmembrane domain has been shown to exhibit isoform-specific homophilic binding in culture assays but not within *in vivo* yet. Nevertheless, the localization of its two isoforms in structurally opposite ends of the neuron (*TM1* in dendrites and *TM2* in axons) suggests that DSCAM may play an important role in determining isoform localization, more so than the variety of extracellular isoforms (Wang et al 2004). Moreover, the ability of *TM2* and *TM1* containing isoforms to rescue axonal and dendritic morphological defects respectively caused by *Dscam* mutations extends its function to enabling proper neuritic branching as well (Wang, 2004).

The presence of a variety of isoforms does not mean that all isoforms are generated at the same time or simultaneously during all stages of development. To test the pattern of *Dscam* variant expression, the alternative splicing of exon four which contains 12 mutually exclusive exons was investigated. Exon 4 pre-mRNA expression was found to be temporally and spatially regulated (Celotto, 2001). The most regulated exon, 4.2 was rarely used in the early embryos but was dominantly expressed in adults. Additionally, different tissues expressed distinct repertoire of *Dscam* isoforms. Along the same lines Neves et al (2004) discovered that despite being random, there is an inherent bias to exon 4.2 expression. They performed microarray analysis following RT-PCR in individual photoreceptor R1-R8 neurons (separated by FACS) to compare the *Dscam* expression in neighboring neurons. Each neuron was shown to express its own complement of distinct isoforms (Zinn, 2007). *In vivo* evidence for the endogenous

function of *Dscam* extracellular domain diversity has yet to be demonstrated. Previous rescue assays with a single extracellular isoform (4.3; 6.36; 9.25) containing both *TM1* and *TM2* domains were required to rescue lethality in *Dscam* mutants (Wang, 2004). Transheterozygous mutants used in these experiments (*Dscam* 18/*Dscam* B17-1) displayed reduced axon bifurcation and segregation defects in the Mushroom body (the olfactory/learning center of *Drosophila* brain). Transgenes with *TM2* not only rescued axonal morphogenesis in mutants but were also better at rescuing lethality than those with *TM1*. On the other hand *TM1* containing isoforms were good at rescuing dendritic defects in mutants suggesting the relative roles of *TM1* and *TM2* isoforms in the dendritic and axonal terminals of a neuron.

To understand significance of the profusion of isoforms, flies with a single isoform composed of variable extracellular and transmembrane domain subsets were used to rescue *Dscam* mutation. Closer examination of the mushroom body and midline regions revealed that these organisms had neurites that were capable of bifurcation but displayed other branching and targeting defects and hence could survive only until early larval stage (Hattori et al, 2007). Fly lines with a reduction in the number of DSCAM isoforms generated by P-element induced deletions as well as alleles with reduced number of isoforms showed a distinct upregulation of certain alternatively spliced isoforms and defects in their targeting precision and neuritic branching (Wang, 2004; Chen, 2006). The non-random, unique repertoire of *Dscam*'s numerous isoforms are believed to not only facilitate neurite branching but are also essential for establishing

target specificity, both of which are fundamental to neuronal wiring in a developing nervous system (Hummel, 2003; Bharadwaj, 2006; Zipursky, 2006).

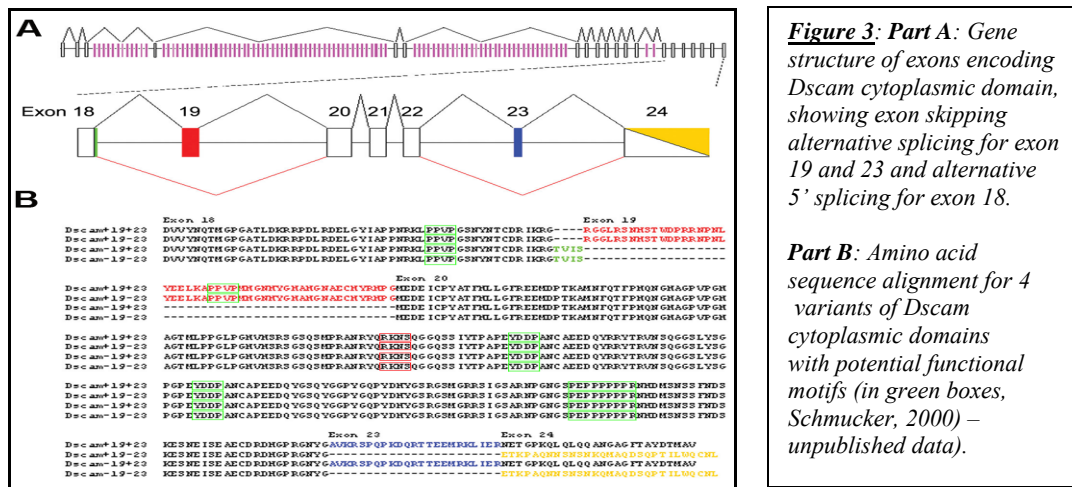
### **Cytoplasmic domain diversity and its implications**

The DSCAM molecular diversity is not just contributed by the extracellular and transmembrane domains alone but also by the cytoplasmic domain. Unpublished studies from our lab suggest that *Drosophila Dscam* cytoplasmic domain may contribute *four* additional variants which bring up the total number of *Dscam* isoforms to 152,032. The four alternative exons are generated by retaining and/or removing exons 19 & 23, with an alternative 5'splice site for exon 18. The *in vivo* expression of these isoforms was confirmed using antibodies raised against peptides specific to exons 18, 19 and 23 in wandering larvae CNS. Different staining patterns were observed among these antibodies. For example, though all three antibodies have similar staining patterns in wandering larval CNS, only antibody against exon 18 recognizes Dscam in the CNS of the late embryo (Data not shown), implying that Dscam with exon 19 and/or exon 23 may be not utilized in the embryonic stage. The biased expression of Dscam cytoplasmic isoforms suggests potential differences in the functions of these isoforms during different stages of development.

The cytoplasmic domain is believed to be the link between the Dscam molecule and its downstream signaling partners. The interaction of Dscam cytoplasmic domain isoforms and intracellular signaling partners could help explain another dynamic way

neuritic branching and extension is regulated. Neuritic branching involves the remodeling of the cytoskeletal elements within a neuron. The functional motifs PXXP known to interact with adaptor molecules like Dock (Schmucker, 2000) and, YDDP which acts like phosphorylation site were initial clues to understanding how DSCAM interacted with its downstream signaling molecules. *In vitro* immunoprecipitation assays have indicated that Dock interacts with the PXXP domain (Schmucker, 2000) and tyrosine kinase Src42A phosphorylates the YDDP domain (Muda, 2001). Besides Dock and Src42A, DSH3PX1, a sorting nexin was found to connect Dscam to cytoskeleton interacting Wasp in biochemical assays (Worby, 2001). Moreover Dock is known to also interact with pak (p-21 activated kinase) which in turn is known to interact with cytoskeletal remodeling proteins (Garrity, 1996; Ang, 2003) These multiple molecular interactions with the different functional motifs in the DSCAM cytoplasmic domain suggest that it could be involved in regulating the cytoskeletal reorganization within a neuron that eventually manifests as neuronal branching.

**Figure 3 : Drosophila *Dscam* potentially encodes 152,064 distinct isoforms**



## Chapter 3: Experimental Methodology

### Generation of *Dscam* Transgenes

In order to test isoform specific rescue capability, different *Dscam* transgenes were generated by Dr. Jian Wang (Unpublished). Full-length *Dscam* cDNA was generated from multiple over-lapping cDNA fragments using RT-PCR from late embryonic total RNA. These fragments were joined by ligation to generate a cDNA composed of exons 1-16 (encoding the extracellular domain) and exon 17 (encoding the transmembrane domain) and a genomic fragment extending from exons 18 to 24 (encoding the cytoplasmic domain). For transgenes used in part I, II and III (Table 1) alternative hybrid cDNA-genomic fragments were used, that included the different exons of the extracellular domain spanning three regions: exons 3-10, exons 10-15 and exons 15-17 (**A** – 4.3-6.36-9.25-17.1 or 17.2; **B** – 4.2-6.18-9.22-17.1 or 17.2; **C** – 4.2-6.14-9.24-17.1 or 17.2) respectively. *Figure 4A* provides a schematic of the A, B and C transgenic lines.

For transgenes used in part IV, the cDNA fragments spanned three different regions: exons 3-10, exons 10-15 and exons 15-24 respectively. All transgenes in part IV had one common variant representing the extracellular and transmembrane domains (**A2**-4.3-6.36-9.25-17.2) and the cytoplasmic domain represented by exons 19 and / or 23 in different combinations *DspDs 1* – (*A-TM2+19+23*); *DspDs 2* - (*A-TM2-19+23*); *DspDs 6* – (*A-TM2-19-23*). These transgenes were individually introduced into the fly genome through P element-mediated germline transformation (Spradling and Rubin, 1982). These

transgenic lines represented one exon subset of each variable exon in the extracellular and transmembrane domains. An endogenous *Dscam* promoter was generated by piecing together two PCR fragments that in combination extended from -261 bp to +4309 bp in the genomic *Dscam* region. This 4.5 kb *Dscam* promoter region was then connected with the different cDNAs to drive their endogenous expression.

**Table 1 – Identities of the Different Dscam Transgenic Lines**

<b><u>Extracellular and Transmembrane Domain Specific Lines</u></b>	<b><u>Subset of Exons</u></b>
A1	4.3-6.36-9.25-17.1
A2	4.3-6.36-9.25-17.2
B1	4.2-6.18-9.22-17.1
B2	4.2-6.18-9.22-17.2
C1	4.2-6.14-9.24-17.1
C2	4.2-6.14-9.24-17.2
<b><u>Cytoplasmic Domain Specific Lines</u></b>	
DspDs1	A-17.2+19+23
DspDs2	A-17.2-19+23
DspDs6	A-17.2-19-23

***Table 1:*** The nomenclature for different lines: A, B and C in the first part of the table refer to extracellular domain specific variant isoforms (4, 6 and 9) with their respective subsets in the second column. The second part of the table lists the cytoplasmic domain specific isoforms all of which have the same extracellular domains subsets (as in line A) paired with TM2 domain (exon 17.2). These isoforms have different combinations of the cytoplasmic domain exons.

**Table 2– Lines generated through p-element mobilization**

<b>Genotype</b>	<b>Number of lines with p-element confirmed on 3rd chromosome</b>	<b>p-element previously on Chromosome</b>
<b>B2(2)</b>	<b>7</b>	<b>2</b>
<b>B1(1)</b>	<b>15</b>	<b>2</b>
<b>C1(2)</b>	<b>15</b>	<b>2</b>
<b>C2(1B)</b>	<b>7</b>	<b>2</b>
<b>A2(2)</b>	<b>16</b>	<b>2</b>
<b>A1(C)</b>	<b>6</b>	<b>2</b>
<b>DspDs1(5)</b>	<b>12</b>	<b>2</b>
<b>DspDs5(9)</b>	<b>8</b>	<b>2</b>
<b>DspDs2(1)</b>	<b>12</b>	<b>3</b>
<b>B2(1)</b>	<b>16</b>	<b>3</b>
<b>DspDs6(2)</b>	<b>1</b>	<b>1</b>
<b>Total Lines</b>	<b>115</b>	

***Table 2:*** P-element mobilization in the Dscam transgenic lines bestowed them with unique genomic location. The chromosomal location of each p-element was confirmed prior to the mobilization and then re-confirmed post-mobilization through crosses that indicated whether p-elements did or did not associate with a certain marker (*sb*) or balancer (*cyo*). All transgenic lines were confirmed to have their p-elements localized within the third chromosome.

Development of genetically unique Dscam transgenic lines using P element Mobilization

P element Mobilization was used to generate multiple insertions of each Dscam transgene described above in *Table 1* (Bingham, 1982). The original *Dscam* transgenic lines had transgenes inserted in either the first, second or third chromosome. Since the *Dscam* gene is on chromosome II, it was necessary to have the Dscam transgenes on the other chromosomes for the rescue experiments. All lines having transgenes on chromosome II were balanced with *Cyo* or *CyoY* and those on chromosome III were balanced with *TM3*. The presence of the transgene was easily detected through the red eye phenotype due to the white gene in the p-element which encoded for red eyes. The  $\Delta 2-3$  line with the Sb (Stubble) bristles marker was used to mobilize the P-elements. It carries a stable source for the enzyme transposase which mobilizes the P-elements.

Transgenes were first crossed to  $\Delta 2-3$  *sb/Tm3* and red eyed, *Cyo* or *CyoY* and Sb flies were selected for the next cross with  $y^w$  recessive mutations. Next red eyed, non-stubble bristled and *Cyo* or *CyoY* progeny from this second cross were selected. Thereafter lines with unique red eye color underwent multiple crosses with *Pin/Cyo* firstly establish the location of their respective transgenes in the third chromosome and then with *Pin/Cyo.GFP; Tm3/Tm6B* lines to generate stocks for the final rescue crosses.

Approximately 100 genetically unique lines were generated from the original transgenic lines (A, B, C, DspDs1, DspDs2, DspDs5 and DspDs 6), of which we managed to salvage only about 50. For the purpose of this experiment 43 lines derived

from the original 50 were used. *Table 2* lists the different lines, the respective chromosome in which the p-element was first located and then the final destination chromosome post-mobilization. *Tables 3 and 4* list the 41 lines were used for the entire project.

**Table 3 – Lines used for Rescue – Part I, II and Part III**

<b>A2 ( 7 Lines )</b>	<b>B2 ( 16 Lines )</b>	<b>C2 ( 9 Lines )</b>
Dscam B 17-1; A2 – 26.1	Dscam B 17-1; B2 – 1.2	Dscam B 17-1; C2 - 24
Dscam B 17-1; A2 – 17	Dscam B 17-1; B2 – 2.1	Dscam B 17-1; C2 - 32
Dscam B17-1; A2 – 36	Dscam B 17-1; B2 – 3.1	Dscam B 17-1; C2 - 44
Dscam 21; A2 – 26.1	Dscam B 17-1; B2 – 7	Dscam 21; C2 - 24
Dscam 21; A2 – 17	Dscam B 17-1; B2 – 8	Dscam 21; C2 - 32
Dscam 21; A1 - 1	Dscam B 17-1; B2 – 11	Dscam 21; C2 - 44
Dscam 21; A1- 3	Dscam B 17-1; B2 – 22	Dscam 21; C1 - 21
	Dscam B 17-1; B2 – 33.1	Dscam 21; C1 - 33
	Dscam B 17-1; B2 – 34	Dscam 21; C1 - 35
	Dscam 21; B2 – 2.1	
	Dscam 21; B2 – 3.1	
	Dscam 21; B2 – 8	
	Dscam 21; B2 – 33.1	
	Dscam 21; B1 - 30	
	Dscam 21; B1 – 37.1	
	Dscam 21; B1 – 44.1	

**Table 4 – Lines used for Rescue – Part IV**

<b>DspDs 1 ( 4 Lines )</b>	<b>DspDs 2 ( 4 Lines )</b>	<b>DspDs 6 (1 Line )</b>
Dscam B17-1; DspDs 1 – 1	Dscam B17-1; DspDs 2 – 9	Dscam B17-1; DspDs 6- 2.2
Dscam B17-1; DspDs 1 – 6	Dscam B17-1; DspDs 2 - 32.2	
Dscam 21; DspDs 1 – 1	Dscam 21; DspDs 2 – 9	
Dscam 21; DspDs 1 – 6	Dscam 21; DspDs 2 – 32.2	

**Table 5 - Lines Used for Crosses between with Two Different Transgenes – Part III**

<b>A2 x B2 Lines</b>	<b>A2 x C2 Lines</b>	<b>B2 x C2 Lines</b>
A2 - 17 x B2 - 2.1	A2 - 17 x C2 - 24	B2 - 2.1 x C2 - 24
A2 - 17 x B2 - 3.1	A2 - 17 x C2 - 32	B2 - 7 x C2 - 24
A2 - 17 x B2 - 7	A2 - 17 x C2 - 44	B2 - 33.1 x C2 - 24
A2 - 17 x B2 - 33.1	A2 - 26.1 x C2 - 24	B2 - 2.1 x C2 - 32
A2 - 26.1 x B2 - 2.1	A2 - 26.1 x C2 - 32	B2 - 7 x C2 - 32
A2 - 26.1 x B2 - 3.1	A2 - 26.1 x C2 - 44	B2 - 33.1 x C2 - 32
A2 - 26.1 x B2 - 7		B2 - 2.1 x C2 - 44
A2 - 26.1 x B2 - 33.1		B2 - 7 x C2 - 44
		B2 - 33.1 x C2 - 44

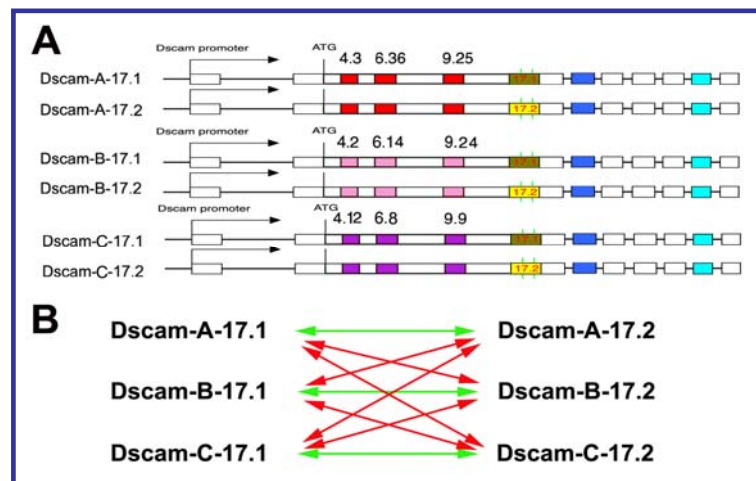
### Genetic Rescue and Mutant characteristics

Multiple *Dscam* transgenic lines generated through p-element mobilization were crossed with *Pin/Cyo.GFP; Tm3/Tm6B* triple balancer lines. *Pin/Cyo.GFP* balancer lines were used to generate stocks for the two *Dscam* mutant lines – *Dscam B17-1* (p-element generated) and *Dscam 21* (EMS generated). These two lines were then crossed with each of the *Dscam* transgenic lines. Preliminary test crosses to generate transheterozygotes (with and without the transgenes) with a select group of lines were first performed with some monitoring (through different developmental stages) to fine-tune the logistics of the data collection method for the rescue experiment. Approximately 100 larvae at first *instar* stage were collected and transferred from the grape juice food (created from agar, grape juice and alcohol) to regular fly food (made from primarily molasses and agar). Initially both GFP and non-GFP first *instar* larvae were used. It was observed that these animals competed for food and other basic necessities with the GFP (non-mutant) larvae surviving better than the non-GFP (mutant) larvae. Additionally, owing to the abundance of GFP larvae in the food vials, it was not easy to distinguish the two kinds of larvae for future developmental monitoring.

So taking all these factors of space and nutrient constraints among GFP and non-GFP larvae as well as the ease of monitoring, the larvae were separated based on the expression of GFP or lack thereof into separate vials. Lines A1, B1, C1, A2, B2, C2 and *DspDs* (1, 2 and 6) were selected for more detailed analysis based on their ability to rescue beyond the third *instar* larval stage. Each transgenic line on chromosome III with the *Dscam* mutation on chromosome II was either crossed with the alternative mutant line

with or without the transgene to test for the influence of single versus double copies of a single transgene. A schematic of possible crosses is given in *Figure 4B*. Overall 76 crosses were performed and 700-800 total larvae (~50 larvae per vial on average) were collected for part I and 30-250 larvae for parts II, III and IV. These were monitored regularly through different stages of development. The number of larvae that survived to third instar, pupal and adulthood were noted.

**Figure 4 : Schematic of *Dscam* Transgenic Lines and Scheme of Crosses**



**Figure 4: Part A** shows the common elements of the cDNA-genomic hybrid Transgenes used in the three lines include: the 4.5 Kb *Dscam* promoter, the presence of either TM1 or TM2 *Dscam* domains (exon 17.1 or 17.2) and the genomic section extending from exons 18-24 (cytoplasmic *Dscam* domain). The lines were composed of three different subsets of variable exons in the extracellular *Dscam* domain. **Part B** illustrates the potential scheme of crosses between different lines for the purpose of rescue with different combinations of the extracellular and transmembrane domains.

## Chapter 4: Results

### **Results Part I - Rescue of *Dscam* mutant using single and double copies of a single *Dscam* transgene with Transmembrane domain II or *TM2***

One of the aims of this study was to understand if there were any individual differences between the different 19,008 *Dscam* extracellular isoforms were used with either *TM1* or *TM2* domains. *Dscam* transgenic lines (Table 3) with extracellular and transmembrane domain specific isoforms were used to test the contribution of these respective *Dscam* domains in the rescue of the transheterozygote mutant – *Dscam 21/ Dscam B17-1*. Based on previous evidence that *TM2* containing isoforms were superior in their ability to rescue lethality caused by *Dscam* mutation (Wang, 2004), the rescue rates of such lines were first tested. For a quantitative analysis, the rescue capacity of a single copy of each *Dscam* transgene versus a double copy was also tested. Differential rescue rates were observed for lines carrying different transgenes – A, B or C. The rescue efficiency within lines carrying the same transgene also varied but the general trend was lines with the C transgene rescued lethality better than those with B or A transgenes. The introduction of two copies of the same transgene within an animal resulted in poor rescue capability (single transgenic copy results in Figure 5 and tables 6, 7 and 8 double copies of the same transgene in table 9 and figure 9).

A total of 24 lines were used for this part of the rescue (using lines with *TM2*) with 5 A2 lines (17, 26.1 and 36 with either *Dscam B17-1* or *Dscam 21* ), 13 B2 lines (1.2, 2.1, 3.1, 7, 8, 11, 22 and 33.1 with either *Dscam B17-1* or *Dscam 21*) and 6 C2 lines

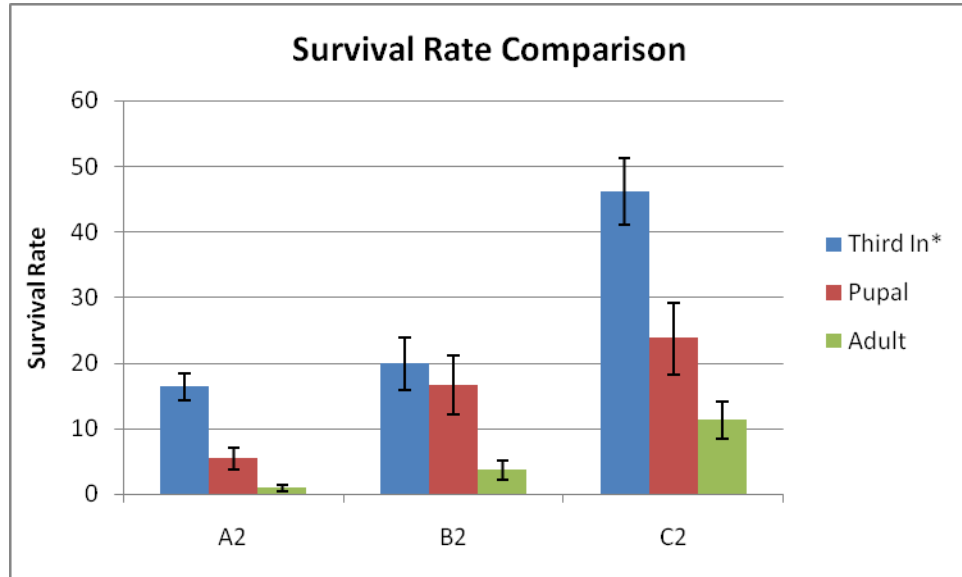
(24, 32 and 44 with either *Dscam B17-1* or *Dscam 21*) being used for rescue with single copy of a single transgene and 9 lines with double copies of the same transgene (*Figures 5-8 and Tables 6-8*). The rescue efficiency in terms of the survival rate was noted for the progeny of each line, beginning at the first *instar* larval stage up to adulthood. The general trend observed was that the single copies of *Dscam* transgene in each line outperformed the double copy transgenic lines in their ability to rescue lethality or promote survival up to adulthood. Among A2 lines A2-26.1 (single copy - 1.89%; double copy - 1.4%) was relatively better at rescuing than A2-17 and A2-36 (< 1% for both single and double copies). Among B2 lines B2-8 (single copy - 6.62%), B2-3.1 (single copy - 6.7%) and B2-33.1 (single copy - 8.45%) had rescue efficiencies better than B2-11 (single copy - 3.75%), B2-1.2 (single copy 2.68%), B2-7 (single copy - 0.99%) and B2-2.1 (single copy - 3.11%). All B2 lines tested with double copies of the transgenes had 0% survival rate - i.e. they could not survive up to the stage of adulthood. Among C2 lines C2-32 (single copy -8.89%; double copy - 3.34%) and C2-44 (single copy - 17.69%; double copy - 10.6%) had better rescue efficiencies than C2-24 (single copy 7.20%; double copy 0.3%).

The progeny that were collected in each case comprised of either GFP (non-mutant) or non-GFP (mutant) larvae. Among the mutant progeny that survived up to adulthood some managed to eclose while the remaining were pharate adults (where the animal would partially or completely emerge from the pupal casing and not survive beyond a single day). The mutants were characterized by the absence of GFP and non-Cyo wings (when eclosed), sluggish with limited body and mouth part (proboscis)

movement. Their development in terms of body parts was seemingly normal since there was no developmental delay in other developmental milestones. The mutant larvae from the negative control crosses managed to survive up to third instar stage with a few that escaped up to pupal stage. Most positive control larvae survived up to adulthood.

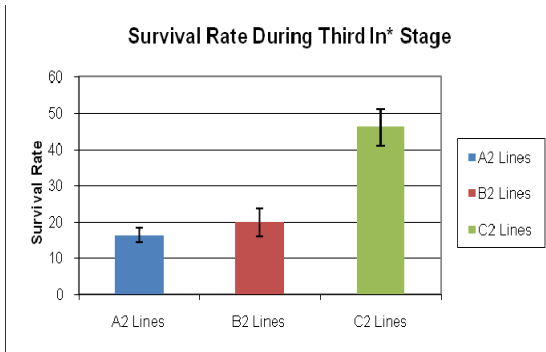
For positive and negative controls 100 first instar larvae were collected for each cross and monitored for survival. On average ~70% or more of the positive controls for each line – i.e. larvae that resembled the parental phenotypes (*Dscam* B17-1 or *Dscam* 21 / cyo.GFP; [*Dscam* transgenes]) survived up to adulthood. Among the negative control larvae (transheterozygote *Dscam* 21/*Dscam* B17-1), 9% survived up to third instar stage, 0.4% survived up to pupal stage and none survived up to adulthood. Overall the survival rate up to adulthood varied between the three lines with *C2* being the most efficient, *B2* intermediate and *A2* the least efficient in rescuing lethality. Statistical analysis for the survival data indicates that there is a significant difference between the rescue efficiencies of the three lines ( $p < 0.05$ ) for rescue up to adulthood.

**Figure 5: Survival Rate Comparison for *TM2* Lines**

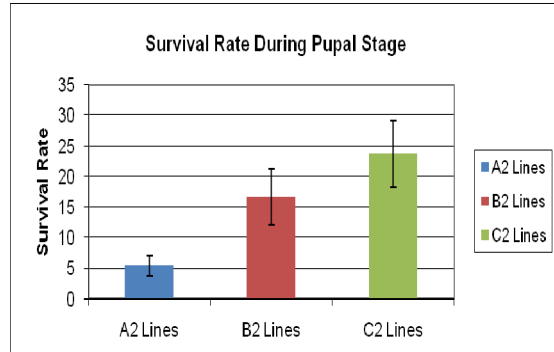


**Figure 5:** Comparison of mean survival rate for the three lines A2, B2 and C2 during the three different stages – Third instar, Pupal and Adult. The error bars in each case correspond to the respective standard deviation between lines A2, B2 and C2 at each developmental stage ( $p$  value < 0.05 for the survival rate of larvae up to adulthood).

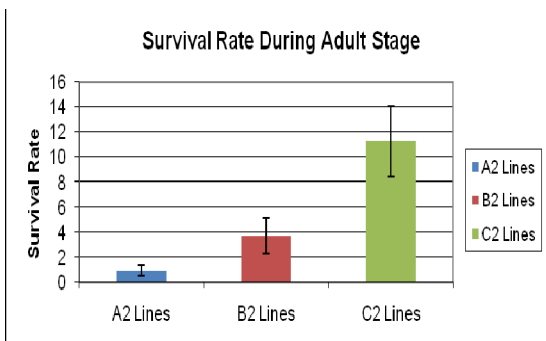
**Figure 6**



**Figure 7**



**Figure 8**



**Figure 6:** Mean survival rates of the three different lines at the third instar larval stage.

**Figure 7:** Mean survival rates of the three different lines at the pupal stage.

**Figure 8:** Mean survival rates of the three different lines at the adult stage.

The error bars in all three graphs are based on the standard deviation between the multiple lines of each corresponding line ( $p$  value < 0.05 for the survival rate of larvae up to adulthood).

**Table 6 - Rescue Using Single Copy of Transgene (TM2) – A2 Lines**

Overall Larval/Pupal/Adult Count					Survival Rate			
A2 Lines	First In*	Third In*	Pupal	Adult	A2 Lines	Larval	Pupal	Adult
A2 - 17	774	134	41	6	A2 - 17	17.31%	5.29%	0.78%
A2 - 26.1	740	148	65	14	A2 - 26.1	20%	8.78%	1.89%
A2 - 36	740	87	16	1	A2 - 36	11.76%	2.16%	0.14%

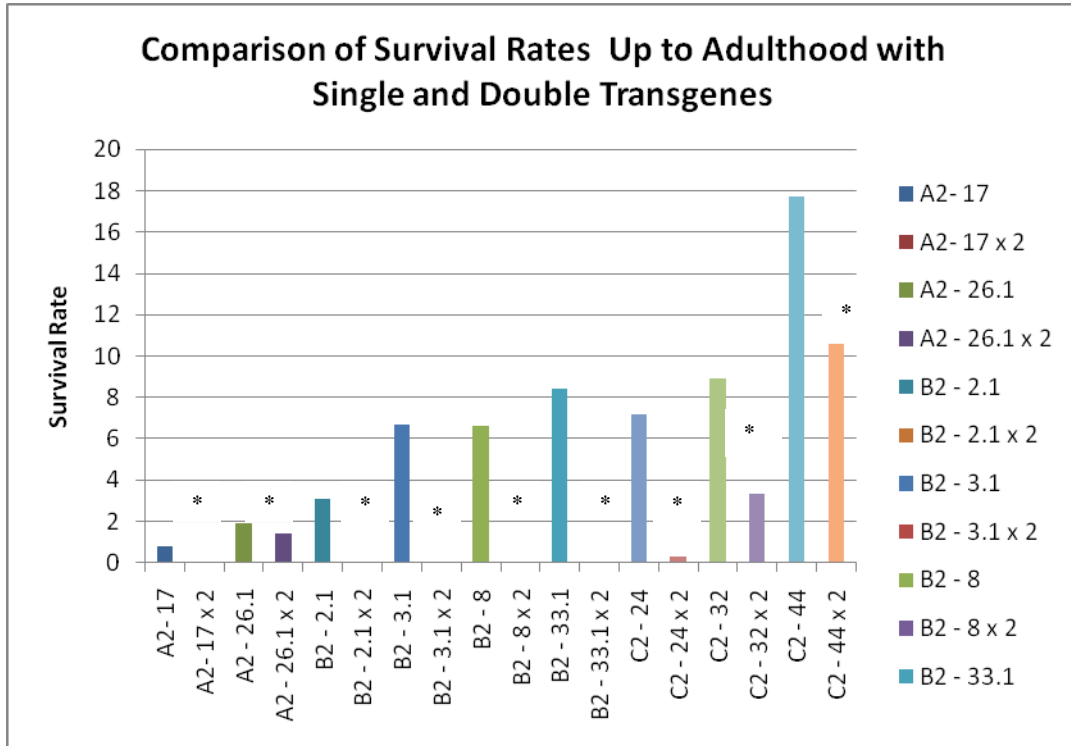
**Table 7 - Rescue Using Single Copy of Transgene (TM2) – B2 Lines**

Overall Data (Larval/Pupal/Adult Count)					Survival Rate			
B2 Lines	First In*	Third In*	Pupal	Adult	B2 Lines	Third In*	Pupal	Adult
B2 - 1.2	708	126	119	19	B2 - 1.2	17.79%	16.80%	2.68%
B2 - 2.1	739	140	117	23	B2 - 2.1	18.94%	15.83%	3.11%
B2 - 3.1	209	62	56	14	B2 - 3.1	29.67%	26.80%	6.70%
B2 - 7	803	124	95	8	B2 - 7	15.44%	11.83%	0.99%
B2 - 8	786	205	166	52	B2 - 8	26.08%	21.12%	6.62%
B2 - 11	746	119	109	28	B2 - 11	15.95%	14.61%	3.75%
B2 - 33.1	746	260	246	63	B2 - 33.1	34.85%	32.97%	8.45%
B2 - 22	724	76	24	2	B2 - 22	10.49%	3.31%	0.27%
B2 - 34	115	52	16	2	B2 - 34	45.22%	13.90%	1.74%

**Table 8 – Rescue Using Single Copy of Transgene (TM2) – C2 Lines**

Overall Data (Larval/Pupal/Adult Count)					Survival Rate			
C2 Lines	First In*	Third In*	Pupal	Adult	C2 Lines	Third In*	Pupal	Adult
C2 - 24	680	248	171	49	C2 - 24	36.47%	25.15%	7.20%
C2 - 32	180	102	22	16	C2 - 32	56.67%	12.22%	8.89%
C2 - 44	791	359	268	140	C2 - 44	45.39%	33.88%	17.69%

**Figure 9: Comparison of Survival Rates Between Single & Double Transgenes**



**Figure 9:** Comparison of the survival rate up to the stage of adulthood for A2, B2 and C2 lines with single versus double transgene. Most lines with double transgenes (represented with \*) have 0% survival rate compared to the respective single transgene lines.

**Table 9 – Rescue Rate with Double Copies of the Same Transgene (TM2)**

Double Copy Transgenes					Rescue Rate		
A2 Lines	First In*	Third In*	Pupal	Adult	Third In*	Pupal	Adult
A2 - 17 x A2 - 17	172	12	2	0	6.98%	1.16%	0%
A2 - 26.1 x A2 - 26.1	142	30	10	2	21.12%	7.04%	1.41%
B2 Lines	First In*	Third In*	Pupal	Adult	Third In*	Pupal	Adult
B2 - 2.1 x B2 - 2.1	76	14	2	0	18.42%	2.63%	0%
B2 - 3.1 x B2 - 3.1	32	1	1	0	3.13%	3.13%	0%
B2 - 8 x B2 - 8	33	4	1	0	12.12%	3.03%	0%
B2 - 33.1 x 2	154	48	40	0	31.17%	25.97%	0%
C2 Lines	First In*	Third In*	Pupal	Adult	Third In*	Pupal	Adult
C2 - 24 x C2 - 24	335	79	42	1	23.58%	12.54%	0.30%
C2 - 32 x C2 - 32	329	107	77	11	32.52%	23.40%	3.34%
C2 - 44 x C2 - 44	132	44	32	14	33.33%	24.24%	10.60%

**Results Part II - Rescue of *Dscam* mutant using single copy of a single *Dscam* transgene with Transmembrane domain I (*TM1*)**

*Dscam* diversity contributed by all three of its domains is significant and, specifically this was demonstrated by testing the same set or cluster of *Dscam* extracellular isoforms with the *TM1* domain to examine the efficiency with which *TM1* contributed to the rescue of *Dscam* mutant. This enabled the testing of any differences between not only between *TM1* and *TM2* but also the extracellular isoforms. A previous rescue study using a single *TM1* isoform demonstrated inferior efficacy in rescuing mutant phenotype compared to *TM2* containing isoform (Wang, 2004). Lines *A1*, *B1* and *C1* (having the same extracellular isoforms as their *A2*, *B2* and *C2* counterparts) had *TM1* as the transmembrane domain and showed similar rescue trends as their *TM2* counterparts implicating the relevance of isoform diversity. Using similar procedures as in part I, ~600 first *instar* larvae were collected and their survival rates monitored through third *instar*, pupal and adult stages.

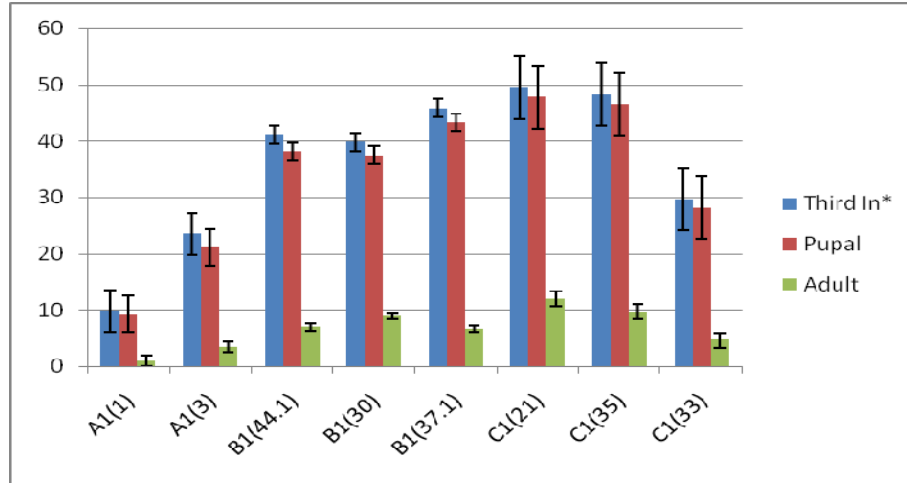
*Table 10* gives the progeny count at each stage as well as the rescue rates. The data reveals that on an average the rescue rates for the lines were as follows: *A1* lines – 2.25%, *B1* lines – 7.56% and *C1* lines – 8.78%. *Figure 10* gives a survival rate comparison for all three lines at the three different stages (third *instar*, pupal and adult) monitored. Statistical analysis for the survival data indicates that there is a significant difference between the rescue efficiencies of the three lines ( $p < 0.05$ ) for rescue up to adulthood. These lines also followed a similar rescue trend as in part I where *C1* lines

outperformed the *BI* and *AI* lines. This seems to suggest the relative bias of the extracellular domain specific isoforms (that maintained similar proportional rescue rate) when combined with the alternative transmembrane isoform. However the presence of the *TMI* domain does not impede the survival rate of the *AI* (2.25%) and *BI* (7.56%) lines which have a greater mean survival rate compared to the *A2* (0.94%) and *B2* (3.7%) lines respectively up to the stage of adulthood. *Figure 11* provides a comparison of the *TMI* and the *TM2* lines. The comparison of these lines indicates that line *C* when paired up with either *TMI* or *TM2* domain has the best survival rate among all of its lines. Line *C1* has a mean survival rate of 8.78% while line *C2* has 11.26%. This trend does not hold true for lines *A* and *B* which show an opposite effect when paired with either *TMI* or *TM2*. Lines *AI* and *BI* as previously states have superior rescue rates compared to *A2* and *B2*, suggesting that *TMI* actually has a positive effect on the survival rate of these lines. This further reinforces our hypothesis *Dscam* isoform diversity (in this case the extracellular and transmembrane isoform diversity) play a significant role in the survival of the organism.

**Table 10: The Larval Count and the Survival Rate for Each of the *TMI* Lines**

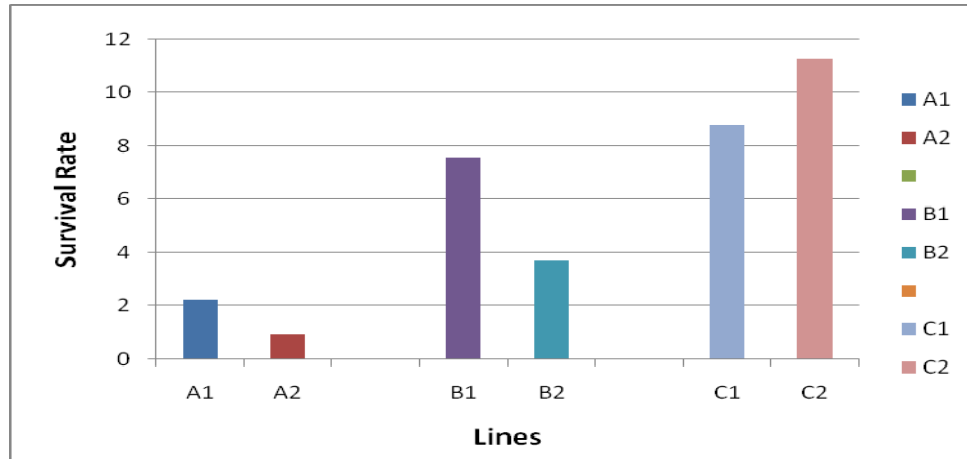
Larval Count (Third In*/Pupal/Adult Stages)				Survival Rate		
Lines	Third In*	Pupal	Adult	Third In*	Pupal	Adult
A1(1)	59	56	6	9.83%	9.33%	1%
A1(3)	141	127	21	23.50%	21.17%	3.50%
B1(44.1)	247	229	42	41.17%	38.17%	7%
B1(30)	239	225	54	39.83%	37.50%	9%
B1(37.1)	275	260	40	45.83%	43.33%	6.67%
C1(21)	297	287	72	49.50%	47.83%	12%
C1(35)	290	279	58	48.30%	46.50%	9.67%
C1(33)	178	169	28	29.67%	28.17%	4.67%

Figure 10: Comparison of the Survival Rate for the *TM1* Containing Lines



**Figure 10:** Comparison of the survival rate during the three developmental stages (third instar larval, pupal and adult) for the *TM1* domain containing lines –A1, B1 and C1. These lines follow a trend similar to the *TM2* lines in that the C1 lines perform better than the A1 and B1 lines, very much like the C2 lines outperforming the A2 and B2 line. Survival rates in general for the *TM1* lines are as good as those for *TM2* containing lines. The error bars in each case correspond to the respective standard deviation between lines A1, B1 and C1 at each developmental stage ( $p$  value  $<0.05$  for the survival rate of larvae up to adulthood).

Figure 11: Comparison of the Mean Survival Rates of the *TM1* and *TM2* Lines



**Figure 11:** The general trend as seen in the above graph is that the C lines (C1 and C2) have higher survival rates (up to the stage of adulthood) compared to the A and B lines. C1 lines do not have a better survival rate than the C2 lines. However the A1 and B1 lines have superior survival rates compared to A2 and B2 lines suggesting the respective significant roles of both the extracellular and transmembrane domains.

### **Results Part III - Rescue of *Dscam* mutant using two different *Dscam* transgenes**

Based on the premise that the survival rate of the *Dscam* mutants could be improved by enhancing *Dscam* diversity, two different transgenes were paired together to rescue the transheterozygote mutant. All transgenes used had different extracellular domain variant representing the variable exons of that domain. The common factor in all the transgenes was the presence of *TM2* domain along with the same stretch of genomic fragment representing the cytoplasmic domain. The rescue rate with two different transgenes was found to be proportionally greater than that with a single transgene (*Table 11*). The rate of larvae that survived up to the third *instar* and pupal stages was similar to the rescue using a single or double transgenes; however during the last stage of development when the pupae approached adulthood, the number of animals that actually surpassed this stage exceeded those in the previous crosses.

Line *A2 – 17* when paired with *B2* lines (*Figure 12: Survival Rate up to Adulthood* → *B2 – 2.1* (2.3%), *B2 – 3.1* (2.92%), *B2 – 7* (1.82%) and *B2 – 33.1* (4.23%)) had a rescue rate that averaged 2.81% with *B2 – 33.1* having the highest rescue rate. Line *A2- 26.1* when paired with *B2* lines (*Figure 13: Survival Rate up to Adulthood* → *B2 – 2.1* (2.85%), *B2 – 3.1* (11.29%), *B2 – 7* (2.79%) and *B2 – 33.1* (11.29%)) had a much better rescue capability than *A2 – 17* lines. It is clearly apparent from these set of crosses that among *B2* lines, *B2 – 33.1* has the best capability in rescuing flies to adulthood when paired up with both *A2 – 17* and *A2 – 26.1* followed by *B2 – 2.1* and *B2 – 3.1*. All three

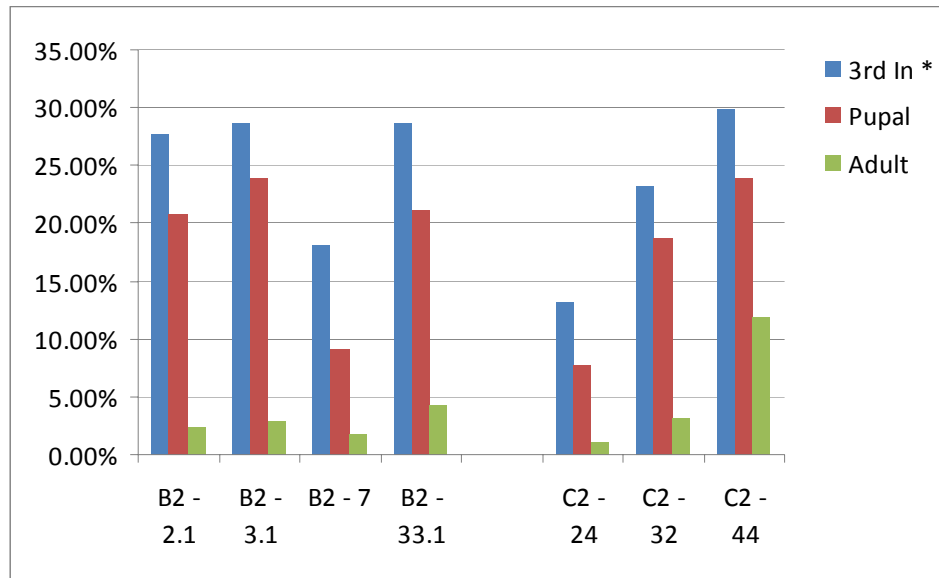
*B2* lines (*B2 - 33.1*, *B2 - 2.1* and *B2 - 3.1*) were also able to single handedly rescue flies by themselves successfully a single transgenic copy was used.

Line *A2 - 17* when paired with *C2* lines (*Figure 12: Survival Rate up to Adulthood* → *C2 - 24* (1.16%), *C2 - 32* (3.16%) and *C2 - 44* (11.94%)) had an average rescue rate of 5.42% with *C2 - 44* having the best rescue rate. When line *A2 - 26.1* was paired with *C2* lines (*Survival Rate up to Adulthood* → *C2 - 24* (7.09%), *C2 - 32* (12.23%) and *C2 - 44* (6.45%)) had an average rescue rate of 8.59%. The rescue rate of *C2* lines with *A2 - 17* shows an expected pattern of rescue where line *C2 - 44* which has consistently shown competent rescue capability by itself has also shown proportionally better rescue ability when paired with the *A2 - 17* line. However, this trend deviates from the expected outcome, when *C2 - 44* line paired up with *A2 - 26.1* does not show a proportionally higher rate than its counterparts *C2 - 32* and *C - 24* respectively (*Figure 13*). The potential reasons for this deviation from this presumed trend will be considered in the discussion section.

Lines *B2* and *C2* were also crossed to look for distinct patterns in rescue capabilities of different lines (*Figure 14*). Line *C2 - 24* when paired with *B2* lines (*Survival Rate up to Adulthood* → *B2 - 2.1* (8.37%), *B2 - 7* (5.04%), *B2 - 33.1* (5.05%)) had a rescue rate that ranged from 5 – 8 %. Line *C2 - 32* when paired with *B2* lines (*Survival Rate up to Adulthood* → *B2 - 2.1* (6.56%), *B2 - 7* (3.40%), *B2 - 33.1* (4.10%)) had a rescue rate that ranged from 3 – 6.5%. Both *C2* lines, *C2 - 24* and *C2 - 32* have somewhat comparable rescuing abilities when paired up with other lines and,

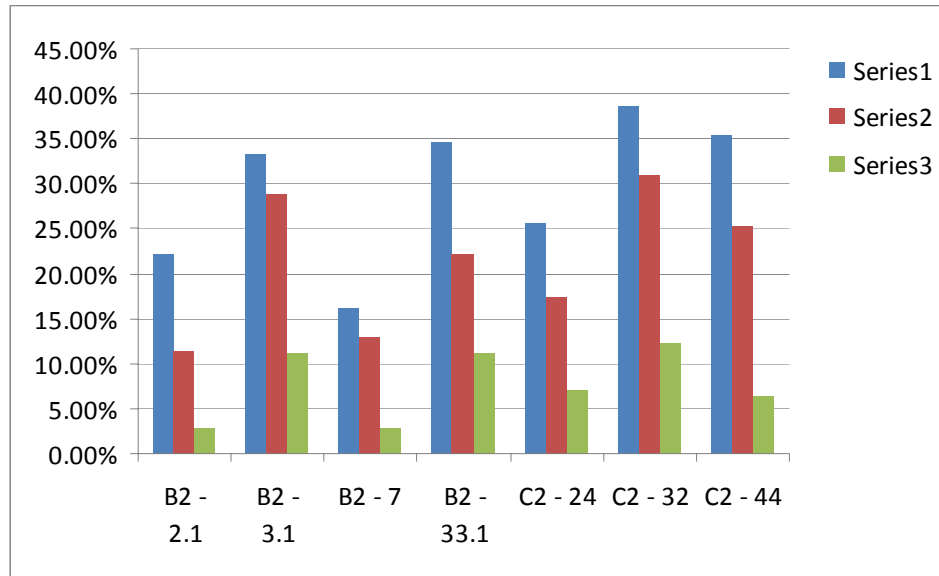
proportionally greater than their individual rescue rates. On another note, *B2* lines do not seem to reflect their individual rescuing capabilities as witnessed in the above crosses where *B2 33.1* distinctly had greater rescue rates than its counterparts *B2 – 2.1* and *B2 – 3.1*. Nevertheless, *B2 – 33.1* has comparable or inferior rescue abilities compared to these lines when paired up with *C2 – 24* and *C2 – 32*. This trend is not mirrored when line *C2 – 44* was paired with *B2* lines (Survival Rate up to Adulthood → *B2 – 2.1* (10.47%), *B2 – 7* (5.84%), *B2 – 33.1* (23.03%)). Overall, lines *B2-33.1* and *C2-44* had significantly greater rescue rates than their counterparts *A2*, *B2* and *C2* lines respectively, individually or in conjunction with other lines.

**Figure 12: Rescue Using Two Different Transgenes (A2 -17 x B2 and C2)**



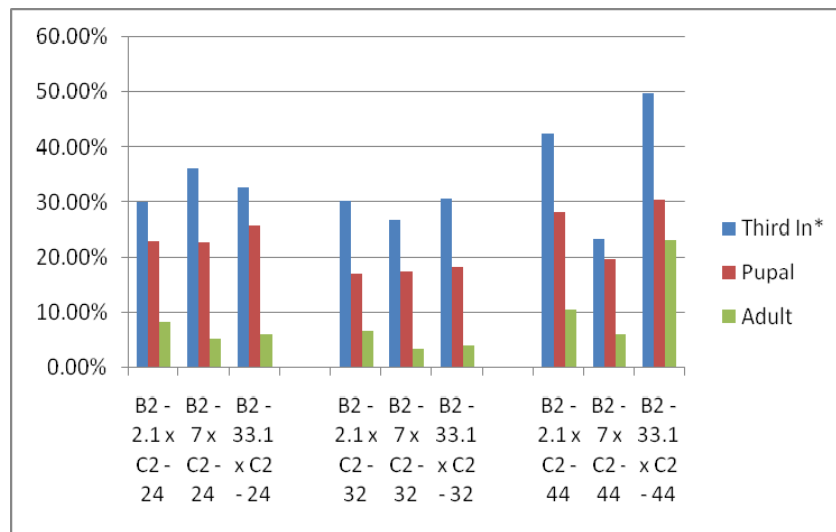
**Figure 12:** The survival rates of lines with two different transgenes used to rescue the mutant phenotype. The survival rates were monitored through three different stages of development for line *A2-17* which was crossed to the respective *B2* and *C2* lines. Rescue with two distinctly different transgenes indicate a significant improvement in survival rate over that of a rescue with a single transgene.

**Figure 13: Rescue Using Two Different Transgenes (A2 -26.1 x B2 and C2)**



**Figure 13:** The survival rates of lines with two different transgenes used to rescue the mutant phenotype. The survival rates were monitored through three different stages of development for line A2-26.1 which was crossed to the respective B2 and C2 lines. Rescue with two distinctly different transgenes indicate a significant improvement in survival rate over that of a rescue with a single transgene.

**Figure 14: Rescue Using Two Different Transgenes (B2 x C2)**



**Figure 14:** The survival rates of lines with two different transgenes used to rescue the mutant phenotype. The survival rates were monitored through three different stages of development for the respective B2 and C2 lines which were crossed with each other. Rescue with two distinctly different transgenes indicate a significant improvement in survival rate over that of a rescue with a single transgene.

**Table 11: Survival Rates of Lines with Two Different *Dscam* Transgenes**

Rescue with Two Different Transgenes					Rescue Rate		
A2 x B2 Lines	First In*	Third In*	Pupal	Adult	Third In*	Pupal	Adult
A2 - 17 x B2 - 2.1	130	36	27	3	27.69%	20.77%	2.30%
A2 - 17 x B2 - 3.1	171	49	41	5	28.65%	23.97%	2.92%
A2 - 17 x B2 - 7	165	30	15	3	18.18%	9.09%	1.82%
A2 - 17 x B2 - 33.1	71	22	15	3	28.57%	21.13%	4.23%
A2 - 26.1 x B2 - 2.1	316	70	36	9	22.15%	11.39%	2.85%
A2 - 26.1 x B2 - 3.1	177	59	51	20	33.34%	28.81%	11.29%
A2 - 26.1 x B2 - 7	322	52	42	9	16.15%	13.04%	2.79%
A2 - 26.1 x B2 - 33.1	239	83	53	27	34.73%	22.18%	11.29%
A2 x C2 Lines	First In*	Third In*	Pupal	Adult	3rd In *	Pupal	Adult
A2 - 17 x C2 - 24	259	34	20	3	13.13%	7.72%	1.16%
A2 - 17 x C2 - 32	504	117	94	16	23.21%	18.65%	3.16%
A2 - 17 x C2 - 44	67	20	16	8	29.85%	23.88%	11.94%
A2 - 26.1 x C2 - 24	282	72	49	20	25.53%	17.38%	7.09%
A2 - 26.1 x C2 - 32	278	106	86	34	38.54%	30.93%	12.23%
A2 - 26.1 x C2 - 44	217	77	55	14	35.48%	25.34%	6.45%
B2 x C2 Lines	First In*	Third In*	Pupal	Adult	Third In*	Pupal	Adult
B2 - 2.1 x C2 - 24	227	68	52	19	29.96%	22.91%	8.37%
B2 - 7 x C2 - 24	119	43	27	6	36.13%	22.69%	5.04%
B2 - 33.1 x C2 - 24	171	56	44	10	32.75%	25.73%	5.85%
B2 - 2.1 x C2 - 32	183	55	31	12	30.05%	16.94%	6.56%
B2 - 7 x C2 - 32	206	55	36	7	26.70%	17.48%	3.40%
B2 - 33.1 x C2 - 32	268	82	49	11	30.60%	18.28%	4.10%
B2 - 2.1 x C2 - 44	191	81	54	20	42.41%	28.27%	10.47%
B2 - 7 x C2 - 44	257	60	50	15	23.35%	19.45%	5.84%
B2 - 33.1 x C2 - 44	165	82	50	38	49.70%	30.30%	23.03%

## **Results Part IV - Rescue using different subsets of all three DSCAM domains**

The DSCAM cytoplasmic domain encodes four isoforms that contribute significantly to the diversity and hence survival of the fly. This part of the rescue was performed using a different set of lines with transgenes that represented the variable exons of all DSCAM domains, including the cytoplasmic. The extracellular domain is represented by line A(4.3-6.36-9.25), the transmembrane domain by *TM2* and the cytoplasmic domain by exons 19 and / or 23 in different combinations (*DspDs 1* – (A-*TM2*+19+23) ; *DspDs 2* - (A-*TM2*-19+23); *DspDs 5* - (A-*TM2*+19-23); *DspDs 6* – (A-*TM2*-19-23)). Two *DspDs 1* lines, namely *DspDs 1 – 1* and *DspDs 1 – 6*, three *DspDs 2* lines and one *DspDs 6* lines generated through p-element mobilization were used for this part. *DspDs 5* lines could not be used because of the inability to obtain a homozygous transgenic line.

The different *DspDs* lines were tested individually with single or double copies (*Table 12 and Figures 15 and 16*). *DspDs 1* lines were relatively more successful in rescuing the larvae up to adulthood when a single transgenic copy was used (Survival Rate up to Adulthood → *DspDs 1 – 1*: single copy – 4.72%, double copy – 1.78%; *DspDs 1 – 6*: single copy – 16.67%, double copy 0%). These lines follow the expected trend as revealed in parts I and II of the results section that single transgenic copies excel in rescuing lethality. Moreover, the rescue rate for single copy of *DspDs 1 – 6* is as good as that of C2 lines. As anticipated using double copies of the same transgene does not yield effective rescue rates.

Among the three *DspDs 2* lines, *DspDs 2 – 32.2* performed much better than the other two (Survival Rate up to Adulthood → *DspDs 2 – 9*: single copy – 0.83%, double copies – 0%; *DspDs 2 – 11*: single copy – 2.61%, double copies – 4.63%; *DspDs 2 – 32.2*: single copy – 4.63%, double copies – 5.07%). *DspDs 2 – 9* showed expected result where its single copy rescued better than its double copy transgene. The only anomaly that was observed was that the rescue capabilities with single and double of lines *DspDs 2 – 11* and *DspDs 2 – 32.2* were comparable. In fact, the rescue with double copies was better. *DspDs 6 – 2.2* was tested with a single copy of its transgene and did not show much promise in terms of its rescue ability (survival rate up to adulthood: 1.97%). These results suggest that despite not having survival rates as high as in part I and II (lines A, B and C), the *Dscam* cytoplasmic domain isoforms significant role in the survival.

**Figure 15: Comparison of Survival Rates of *DspDs* Lines (with single copy)**

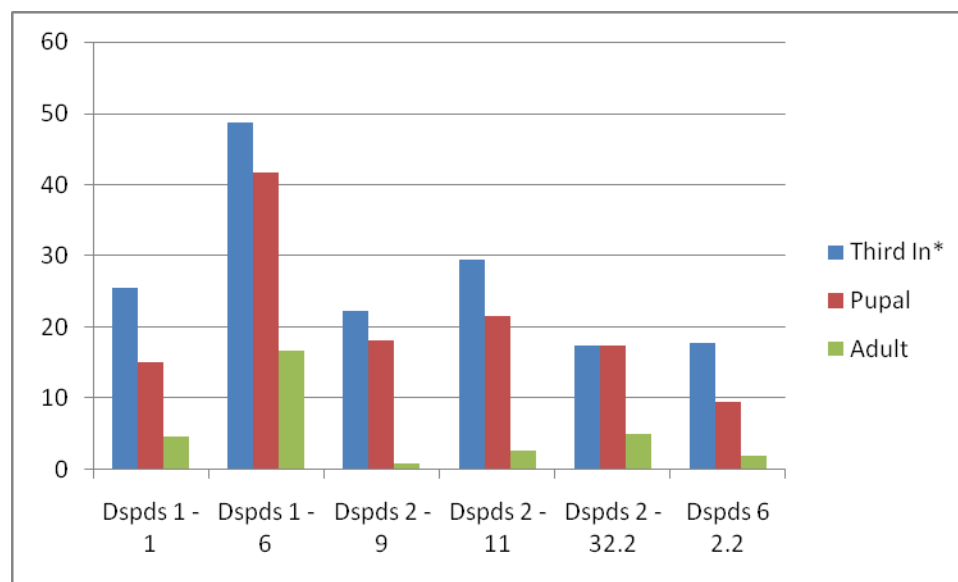
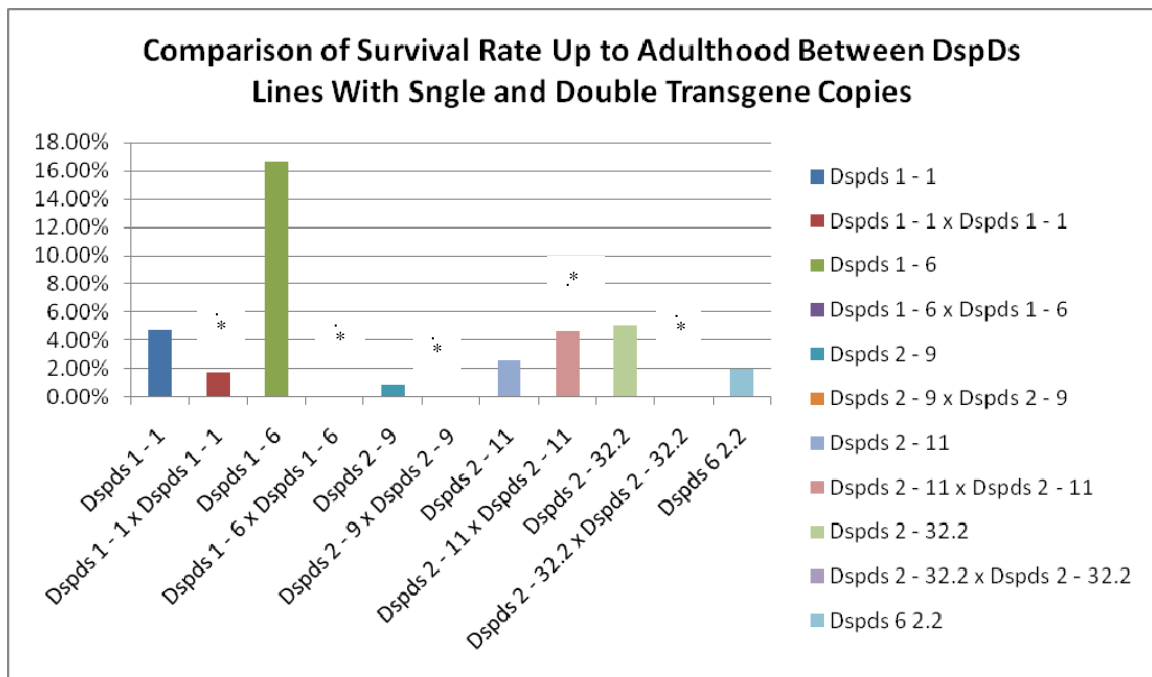


Figure 15: Comparison of the survival rates during the three different stages of *DspDs* lines with single transgene copy.

Table 12: Survival Rates for the Single and Double *DspDs* transgenic lines during the Three Stages of Development

Rescue with <i>DspDs</i> Lines					Rescue Rate		
	Lines	First In*	Third In*	Pupal	Adult	Third In*	Pupal
Dspds 1 - 1	106	27	16	5	25.50%	15.09%	4.72%
Dspds 1 - 1 x 2	225	40	39	4	17.78%	17.34%	1.78%
Dspds 1 - 6	72	35	30	12	48.61%	41.67%	16.67%
Dspds 1 - 6 x 2	151	35	7	0	23.18%	4.64%	0%
Dspds 2 - 9	121	27	22	1	22.31%	18.18%	0.83%
Dspds 2 - 9 x 2	52	2	2	0	3.85%	3.85%	0%
Dspds 2 - 11	268	79	58	7	29.50%	21.64%	2.61%
Dspds 2 - 11 x 2	108	22	16	5	20.37%	14.81%	4.63%
Dspds 2 - 32.2	138	24	24	7	17.40%	17.40%	5.07%
Dspds 2 - 32.2 x 2	162	31	16	0	19.13%	9.88%	0%
Dspds 6 2.2	253	45	24	5	17.78%	9.48%	1.98%

**Figure 16: Comparison of Survival Rate of Single & Double copy *DspDs* lines**



**Figure 16:** Comparison of the survival rates up to adulthood in *DspDs* lines with single and double copies (\*) of the the *DspDs* transgene. These lines also follow the same trend observed in the A2, B2 and C2 lines where the single transgenic lines have better rescue efficiencies than those with double transgenes.

## Chapter 5: Discussion

The focus of this study was to obtain insight into how differently the multiple *Dscam* isoforms rescue the mutant larvae and hence contribute to the survival of the fly. The rescue experiments using domain specific isoforms showed differential rescue capabilities suggesting specific roles for each *Dscam* isoform cluster. Part I, II and III of the results emphasized the rescuing abilities of the isoforms specific to the extracellular and transmembrane domains and Part IV highlighted the contribution of the cytoplasmic domain isoforms. The results suggested that a) there were significant individual differences between the different isoforms belonging to the same domain, b) each domain contributed to the survival of the organism in a positive instead of an antagonistic way, c) the introduction of additional copies of the same isoforms had an inhibitory effect on the survival rate and, d) the introduction of two different isoforms enhanced the survival rate of the mutants further providing evidence in favor of diversity being crucial for the survival of the fly.

The single transgenic copy of either *TM1* or *TM2* based isoforms when combined with lines A, B and C representing the extracellular domain isoforms were successful in rescuing *Dscam* mutants compared to the negative control (*Tables 5-8 & 10; Figures 6-8 & 10-11*). It was apparent from the outset that lines A2, B2 and C2 required only a single copy of their respective isoforms to restore viability. Increasing the number of copies of the same isoform to two had limited or no effect in rescuing the flies. In each case single transgenes representing single isoforms outperformed double copies of the same

transgene in rescuing lethality (*Table 9 & Figure 9*). It is fair to assume that the presence of an extra copy of the same transgene simulated more of an overexpression than a rescue of lethality. This could possibly be due to an unknown threshold of the number of the identical *Dscam* isoforms that the organism can tolerate before which it would be considered a gain of function. There is previous precedence that the gene dosage causes abnormal phenotype as observed in the extra dose of chromosome 21 genes which causes Down syndrome and its associated phenotypes, although this may not be due to *Dscam* since chromosome 21 by itself also encodes other genes that are possibly responsible for the some of these phenotypes.

Individually, several lines had a rescue potential of over 5% and most of these lines were either B1, C1, B2 or C2 lines. Besides having *TM1* or *TM2* domain as a common factor, these lines had the extracellular domain variable exon 4, subset 4.2 indicating that this subset plays a potentially important role in the survival of the fly (*Table 1*). Moreover, this exon subset has been previously shown to be highly regulated. Exon 4.2 is rarely expressed in the early stages of development but highly expressed prior to the onset and during adulthood (Celotto, 2001; Neves, 2004). The other exon subsets used in lines B and C include 6.36, 6.18, 9.25 and 9.22 all of which are expressed during later stages of development (Neves, 2004), especially in the brain and photoreceptor cells. The combined expression of these exons may have allowed the fly to fulfill the specific functions in order to survive up to adulthood.

Among the lines that performed well in the rescue using a single transgene (part I), line C2 – 44 (rescue rate 17.69%) had the best rescue efficiency when used individually in single as well as double copy form. Similarly C2 – 32 (rescue rate 9%) also performed relatively better than the other B2 and C2 lines (Table and Figure). Other corresponding lines with *TM1* (part II) and superior rescue efficiencies were the C1 lines (C1-21; C1-35; C1-33 *Table 10* and *Figures 10-11*). Among all C lines (with TM1 or TM2) C2-44 performed the best. One unique aspect about C2 – 44 was that a very negligible number of rescued flies actually survived beyond the pharate adult stage which was not observed for any other line. This could possibly be a reflection of the significance of the site of insertion of the P-element carrying this transgene within the genome. The insertion point potentially could determine the differential regulation of the expression of this transgene. C2 – 44 possibly had an ideal site of insertion which was demonstrated by its enhanced rescue efficiency compared to other C2 lines carrying the same transgene albeit at different points of insertion in the genome.

In the third part of the experiment, rescue rate improved upon introduction of a single copy of a different isoform which varied only in the extracellular domain. This enabled the comparison of rescue capabilities of distinct isoforms individually and in combination. A proportional increase in the rescue rate was observed when a transgene with superior rescuing ability was used with another transgene. Irrespective of whether an individual transgene rescued satisfactorily by itself (i.e. with a rescue rate of 5% or greater), all transgenes when used in combination rescued much better than they individually did. Lines B2 (3.1, 8, 33.1) and C2 (32 and 44) performed better when

crossed with A2 (*Table 11 & Figures 12-14*). The A2 – 26.1 lines rescued better than A2 – 17 when used in combination with other lines as expected. Lines C2 – 44, C2 – 32, B2 – 3.1 and B2 – 33.1 when paired-up with other lines, had consistently better rescue efficiencies. Lines B2 – 33.1 and C2 – 44 when used in combination rescued approximately 20% of the larvae, demonstrating the best rescue efficiency in agreement with their individual rescue efficiencies. It was once again evident that B2 and C2 lines outperformed A2 lines suggesting that the common factor of exon 4.2 subset may potentially contribute to the survival of the larvae up to adulthood.

A notable quality of the rescue was the fact that there were individual differences in the rescuing abilities of different isoforms. This could mean several things: a) that different isoforms affect the survival of the fly differently, b) the expression of isoforms is not entirely random and each isoform has a specific role; this is in agreement with previous findings that expression of *Dscam* isoforms in the R7 cells is temporally and spatially regulated (Neves, 2004), and c) the reason that one particular isoform has superior rescue qualities may not have to do with the isoform by itself but the tissue in which it is expressed and its insertion site within the genome. The site of insertion influences the nature of its expression – i.e. time or stage of development it is expressed as well as the regulatory elements that control its expression in a specific tissue. All these factors could explain subtle differences in the rescue rates of very similar variants that vary only by a single exon subset.

One of the eminent features of the rescue was the transheterozygote mutant larvae which had distinct characteristics such as reduced body and mouth part mobility, possibly as a consequence of the reduced diversity of *Dscam* affecting the neuro-muscular junction – after all the foundation of all necessary networks including the nervous, circulatory and muscular are founded during early stages of development. The developmental parallels between the nervous and circulatory systems include anatomical similarities like arborization and modes of migration of precursor embryonic cells, neurons and glia in the nervous system while mural and endothelial cells in circulatory system and the flow of information from axons to dendrites (plus efferent and afferent neurons) being analogous to veins and arteries in the circulatory system (Shima, 2000). Given the fact that *Dscam* is expressed in the circulatory system and there are many parallels between the nervous and circulatory systems, it is plausible that *Dscam* plays an important role in the survival of the fly.

Most studies on *Dscam* have focused on understanding the functions of the extracellular and transmembrane domain. Studies from our lab have shown that the cytoplasmic domain produces four variants from alternative splicing; all of these are present *in vivo* and hence are functionally significant. The results in part IV have indicated that among transgenes encoding different combinations of the three cytoplasmic domain specific isoforms, two transgenes (*DspDs 1* and *DspDs 2*) had comparable results (*Table 12 & Figures 15-16*). Both these transgenes had exon 23 as the common element. Additionally, line *DspDs 1-6* (with both exons 19 and 23) performed extraordinarily better than all other lines (rescue rate of ~16%). The *DspDs 6 – 2.2* (exons 19 and 23

absent) line had less than significant rescue capability (~1%) which suggests that even though it may occur naturally, it may work in conjunction with other isoforms to facilitate the survival of the fly. The presence of both exons 19 and 23 seems to be pivotal to the survival of the fly. Exon 19 is known to have a PXXP binding sites that allows *Dscam* to associate with Dock. Therefore, *Dscam* cytoplasmic domain isoforms that do not contain exon 19 may have weaker interaction with Dock *in vivo*. Exons 19 and 23 were also not found to be expressed in earlier stages of development from expression studies using antibodies directed specifically against the peptides of these exons. This may also be a reflection of why these late expressing exons could be important for survival up to adulthood.

It has been a general observation that the cytoplasmic domains of axon guidance molecules like Roundabout (Robo) and Frazzled (Fra) have specialized functions. Fra is a DCC-like (Deleted in colorectal carcinoma) netrin receptor that mediates attraction and Robo is a slit receptor that mediates repulsion. In a genetic study that swapped the cytoplasmic domains of Robo and frazzled, opposite filopodial reactions were observed; i.e. Fra ectodomain and Robo's cytoplasmic domain function together as a repulsive netrin receptor while Robo ectodomain and Fra's cytoplasmic domain function as an attractive slit receptor. In other words the action to be attracted or repelled by an external activating factor was determined by the cytoplasmic domain (Bashaw, 1999). The cytoplasmic domain in *Dscam* could potentially have a function analogous to these axon guidance molecules. Axon guidance molecules typically have different genes (paralogs) encode different versions of the same molecule instead of one gene encoding different

isoforms through alternative splicing as in the case of *Dscam*. For instance, Robo, Robo2 and Robo3 function in different parts of the nervous system regulating the guidance of different sets of neurons while *Dscam* uses a single gene to generate a plethora of isoforms to function in different parts of the nervous system. However, some redundancy among *Dscam* isoforms may exist. There has been precedence for different molecules (again paralogs – Slit1, Slit2 and Slit3 in this case) that function in a compensatory fashion. Mice lacking axon guidance molecules Slit1 and Slit2 did not produce any guidance defects; however these mice were still expressing Slit3 which possibly compensated for their absence (Chilton, 2006). But they produced defects in the generation of optic chiasm where Slit3 is not expressed. Thus unlike other axon guidance molecules *Dscam* is unique in that it is a single gene that encodes for a variety of isoforms that essentially function as different molecules possibly with specialized functions.

It has been difficult to ascertain the precise molecular mechanism by which *Dscam* regulates neuritic branching. Axon guidance molecules have been known to perceive external cues and communicate this information to downstream signaling partners. *Dscam* has been previously shown to interact with adaptor protein Dock (with its PXXP motif) and through Dock, with Pak which is known to interact with cytoskeletal-regulating proteins. This could be one of the pathways which *Dscam* targets. However, *Dscam*'s gain of function phenotype is much more severe in the MB than that of Dock or Pak (unpublished studies). Moreover, *Dscam* has been shown to interact in vitro with tyrosine kinase Src42A (Muda, 2002) and sorting nexin DSH3PX1 (Worby,

2001) and, has phosphorylation sites in the cytoplasmic domain serving as potential binding sites for kinases and other signaling partners - all these factors indicate that it may be interacting directly or indirectly with other signaling and cytoskeleton remodeling elements.

*Dscam*'s role in regulating neuritic branching through cytoskeletal reorganization may not be novel. The link between CAMS and cytoskeletal proteins like GAP-43, spectrin (in the case of NCAMS) and nexin (in the case of *Dscam*) suggests how their signaling may manifest as growth cone formation and eventually neuronal wiring (Ditlevsen, 2007; Worby, 2001). Localized expression of distinct cadherins can contribute to the compartmentalization in the central nervous system, the development of neuronal networks by sorting neuronal fiber fascicles and the stabilization of axo-dendritic synaptic contacts (Theiry 2003). Unlike some other cell adhesion molecules which may express limited number of multiple variants, *Dscam* expresses more than 150,000 isoforms allowing it to potentially be functionally diverse.

The molecular mechanism or the sequence of events by which *Dscam* directly or indirectly assists in the survival of the fly is unknown. The results from this study suggest that it contributes to the survival of the fly and hence may potentially interact indirectly with elements that control cell death and differentiation. The differential rescue capabilities of different *Dscam* isoforms indicate that each isoform potentially has a specific role directly or indirectly on the survival of the organism.

## References

- Agarwala, K. L., Nakamura, S., Tsutsumi, Y., and Yamakawa, K. Down Syndrome cell adhesion molecule *Dscam* mediates homophilic intercellular adhesion. *Molecular Brain Research*. 2000. 79, 118-126.
- Agarwala, K.L., Ganesh, S., Tsutsumi, Y., Suzuki, T., Amano, K. and Yamakawa, K. Cloning and Functional characterization of DSCAML1, a novel DSCAM-like cell adhesion molecule that mediates homophilic intercellular adhesion. *Biochemical and Biophysical Research Communication*. 2001. 285, 760-772.
- Agarwala, K.L., Ganesh, S., Tsutsumi, Y., Suzuki, T., Amano, K. and Yamakawa, K. DSCAM, a highly conserved gene in mammals, expressed in differentiating mouse brain. *Biochemical and Biophysical Research Communication*. 2001. 281, 697-705.
- Ang, L., Kim, J., Stepensky, V., Hing, H. Dock and Pak regulate olfactory axon pathfinding in *Drosophila*. *Development*. 2003. 130, 1307-1316.
- Barlow GM, Chen XN, Shi ZY, Lyons GE, Kurnit DM, Celle L, Spinner NB, Zackai E, Pettenati MJ, Van Riper AJ, Vekemans MJ, Mjaatvedt CH, Korenberg JR. (2001a). Down syndrome congenital heart disease: a narrowed region and a candidate gene. *Genet Med*. 3(2):91-101.
- Barlow, G.M., Lyons, G.E., Richardson, J.A., Sarnat, H.B., and Korenberg, J.R. DSSCAM: an endogenous promoter drives expression in the developing CNS and neural crest. *Biochemical and Biophysical Research Communication*. 2002. 299, 1-6.
- Barlow, G.M., Micales, B., Chen, X., Lyons, G.E. and Korenberg, J.R. Mammalian DSCAMS: roles in the development of the spinal cord, cortex and cerebellum? *Biochemical and Biophysical Research Communication*. 2002. 293, 881-891.
- Bashaw, G. J. and Goodman, C. S. Chimeric Axon Guidance Receptors: The Cytoplasmic Domains of Slit and Netrin Receptors Specify Attraction versus Repulsion. *Cell*. 1999 Vol. 97, 917–926.
- Baumann, J. Down syndrome cell adhesion molecule--a common determinant of brain and heart wiring. *Pediatric Res*. 2007. 62(1):1
- Bharadwaj, R., and Kolodkin, A.L. Descrambling DSCAM Diversity. *Cell*. 2006. 125, 421-424.
- Bingham, P. M., Kidwell, M. G. and Rubin, G. M. The molecular basis of P-M hybrid dysgenesis: the role of the *P* element, a P-strain-specific transposon family. *Cell*. 1982. 29: 993–1004.

- Celotto, A. M. and Gravelly, B.R. Alternative splicing of the *Drosophila* Dscam Pre-mRNA temporally and spatially regulated. *Genetics*. 2001. *159*, 599-608.
- Chen, B.E., Kondo, M., Garnier, A., Watson, F.L., Puettmann-Holgado, R., Lamar, D.R. and Schmucker, D. The molecular diversity of Dscam is functionally required for neuronal wiring specificity in *Drosophila*. *Cell*. 2006. *125*, 607-620.
- Chilton, J. K, Molecular Mechanisms of axon guidance. *Developmental Biology*. 2006.
- Crayton, M.E., Powell, B.C., Vision, T.J., and Giddings, M.C. Tracking the evolution of alternatively spliced exons of Dscam family. *BMC Evolutionary Biology*. 2006. *6*:16
- Ditlevsen, D.K., Povlsen, G. K., Berezin, V., Bock, E. N-CAM-induced intracellular signaling revisited. *Journal of Neuroscience Research*. 2007. Nov 1 (advance print).
- Garrity, P.A., Rao, Y., Salecker, I., McGlade, J., Pawson, T. and Zipursky, S.L. *Drosophila* Photoreceptor Axon Guidance and Targeting Requires the Dreadlocks SH2/SH3 Adapter Protein. *Cell*. 1996. *85*, 639-650.
- Gravelly, B.R. Mutually exclusive splicing of the insect Dscam pre-mRNA directed by competing intronic RNA secondary structures. *Cell*. 2005. *Vol123*, 65-73.
- Gravelly, B.R., Kaur, A., Gunning, D., Zipursky, S.L., Rowen, L., and Clemens, J.C. The organization and evolution of the Dipteran and Hymenopteran Down syndrome cell adhesion molecule (Dscam) genes. *RNA*. 2004. *10*, 1499-1506.
- Hing, H., Xiao, J., Harden, N., Lim, L., and Zipursky, S.L. Pak functions downstream of Dock to regulate photoreceptor axon guidance in *Drosophila*. *Cell*. 1999. *Vol97*, 853-863.
- Hughes, M.E., Bortnick, R., Tsubouchi, A., Baumer, P., Kondo, Masahiro, Uemura, T. and Schmucker, D. Homophilic Dscam interactions control complex dendrite morphogenesis. *Neuron*. 2007. *54*, 417-427.
- Hummel, T., Vasconcelos, M.L., Clemens, J.C., Fishilevich, Y., Vosshall, L.B., Zipursky, S.L. Axonal targeting of olfactory receptor neurons in *Drosophila* is controlled by Dscam. *Neuron*. 2003. *Vol37*, 221-231.
- Jefferis, G.S.X.E Wiring specificity: axon-dendrite matching refines the olfactory map. *Current Biology*. 2006. *Vol 16 No. 10*, 373-376.
- Kidd, T., Condrón, B. Avoiding the SCAMS. *Neuron*. 2007. *54*, 350-352.
- Kohmura, N., Senzaki, K., Harnada, S., Kai, N., Yasuda, R., Watanabe, M., Ishii, H., Yasuda, M., Mishina, M., and Yagi, T. Diversity revealed by a novel family of cadherins expressed in neurons at a synaptic complex. *Neuron*. 1998. *Vol 20*, 1137-1151.

- Kreahling, J.M. and Gravelly, B.R. The iStem, a long-range RNA secondary structure element required for efficient exon inclusion in the *Drosophila* Dscam pre-mRNA. *Molecular and Cellular Biology*. 2005. Vol25, No.23, 10251-10260.
- Li, W., and Guan, K. The Down syndrome cell adhesion molecule (Dscam) interacts with and activates Pak. *JBC*. 2004. Vol279, No. 31, 32824-32831.
- Matthews, B.J., Kim, M.E., Flanagan, J.J., Hattori, D., Zipursky, L.S., Grueber, W.B. Dendrite Self-Avoidance is controlled by Dscam. *Cell*. 2007. 129, 593-604.
- Meijers, R., Peuttmann-Holgado, R., Skiniotis, G., Liu, J., Walz, T., Wang, J., and Schmucker, D. Structural basis of Dscam isoform specificity. *Nature*. 2007. Vol449, 487-493.
- Millard, S.S., Flanagan, J.J., Pappu, K.S., Wu, W., and Zipursky, S.L. Dscam2 mediates axonal tiling in the *Drosophila* visual system. *Nature*. 2007. Vol447, 720-725.
- Missler, M., and Sudhof, T.C. Neurexins: three genes and 1001 products. *Trends in genetics*. 1998, Vol14 No. 1, 20-26. Review
- Muda, M., Worby, C. A., Simonson-Leff, N., Clemens, J.C. and Dixon, J.E. Use of double-stranded RNA-mediated interference to determine the substrates of protein tyrosine kinases and phosphatases. *Biochem J*. 2002. 366, 73-77.
- Neves, G., Zucker, J., Daly, M., Chess, A. Stochastic yet biased expression of multiple Dscam splice variants by individual cells. *Nature*. 2004. Vol36 No. 3, 240-246.
- Schmucker, D., Clemens, C., Shu, H., Worby, C.A., Xiao, J., Muda, M., Dixon, J.E., and Zipursky, S.L. *Drosophila* Dscam is an axon guidance receptor exhibiting extraordinary molecular diversity. *Cell*. 2000. Vol 101, 671-684.
- Shima, D.T. and Mailhos, C. Vascular developmental biology: getting nervous. *Current Opinion in Genetics & Development* 2000, 10:536–542
- Rao, Y. Dissecting Nck/Dock signaling pathways in *Drosophila* visual system. *International Journal of Biological Sciences*. 2005. 1, 80-86.
- Theiry, J. P. Cell adhesion in development: a complex signaling network. *Current opinion in genetics and development*. 2003. 12, 365-371. Review .
- Wang, J., Ma, X., Yang, J.B., Zheng, X., Zugates, C.T., Lee, C.J., and Lee, T. Transmembrane/Juxtamembrane domain-dependent Dscam distribution and function during mushroom body neuronal morphogenesis. *Neuron*. 2004. Vol 43, 663-672.

Wang, J., Zugates, C.T., Liang, I.H., Lee, C.J., and Lee, T. *Drosophila* Dscam is required for divergent segregation of sister branches and suppresses ectopic bifurcation of axons. *Neuron*. 2002. Vol 33, 559-571.

Wells GL, Barker SE, Finley SC, Colvin EV, Finley WH. (1994). Congenital heart disease in infants with Down's syndrome. *South Med J*. 87(7):724-7.

Wojtowicz, W. M., Flanagan, J.J., Millard, S.S., Zipursky, S.L. and Clemens, J.C. Alternative Splicing of *Drosophila* Dscam generates Axon Guidance receptors that exhibit isoform-specific homophilic binding. *Cell*. 2004. 118, 619-633.

Wojtowicz, W.M., Wu, W., Andre, I., Qian, B., Baker, D., and Zipursky, S.L. Vast repertoire of Dscam binding specificities arises from modular interactions of variable Ig domains. *Cell*, 2007. 130, 1134-1145.

Worby, C.A., Simonson-Leff, N., Clemens, J.C., Kruger, R.P., Mudas, M. and Dixon, J.E. The sorting Nexin, DSH3PX1, connects the axonal guidance receptor, Dscam, to the actin cytoskeleton. *The Journal of Biological Chemistry*. 2001. Vol 276, No. 45, 41782-41789.

Wu, Q., and Maniatis, T. A striking organization of a large family of human neural cadherin-like cell adhesion genes. *Cell*. 1999. Vol 97, 779-790.

Yamakawa. K. Huo, Y., Haendel, M., Hubert, R., Chen, X., Lyons, G.E., Korenberg, J.R. Dscam: a novel member of the immunoglobulin superfamily maps in a Down syndrome region and is involved in the development of the nervous system. *Human Molecular Genetics*. 1998. Vol7, No.2, 227-237.

Yang Q, Rasmussen SA, Friedman JM. (2002). Mortality associated with Down's syndrome in the USA from 1983 to 1997: a population-based study *Lancet*. 359(9311):1019-25

Zhan, X. Clemens, J.C., Neves, G., Hattori, D., Flanagan, J.J, Hummel, T., Vasconcelos, M.L., Chess, A. and Zipursky, S.L. Analysis of Dscam diversity in regulating axon guidance in *Drosophila* mushroom body. *Neuron*. 2004. Vol43, 673-686.

Zinn, K. Dscam and neuronal uniqueness. *Cell*. 2007. 129, 455-456. Review

Zipursky, S.L., Wojtowicz, W.M., and Hattori, D. Got diversity? Wiring the fly brain with Dscam. *Trends in Biochemical Sciences*, Review. 2006. Vol31, No. 10, 581-588. Review