

SRC TR 86-42

**Delay Analysis of Interacting
Queues with an Approximate Model**

by

A. Ephremides and Rong-Zhu Zhu

DELAY ANALYSIS OF INTERACTING QUEUES WITH AN APPROXIMATE MODEL

by

Anthony Ephremides
The University of Maryland

and

Rong-Zhu Zhu
China Signals & Communications Co.

ABSTRACT

An approximate model of coupled Markov chains is proposed and analyzed for a slotted ALOHA system with a finite number of buffered nodes. This model differs from earlier ones in that it attempts to capture the interdependence between the nodes. The analytical results lead to a set of equations that, when solved numerically, yield the average packet delay. Comparison between computational and simulation results for a small number of nodes show excellent agreement for most throughput values, except for values near saturation. Numerical comparisons for a two-node system show that a non-symmetric loading of the system provides better delay-throughput performance than a symmetric one.

1. INTRODUCTION

Numerous papers have appeared in the literature that study and analyze the protocol of slotted ALOHA. However most of them either concentrate on capacity analysis or assume an infinite user population that implies no queueing of packets at the terminals. The case of a finite number of terminals that receive packets from exogenous sources and that provide buffer space for queueing is of interest because it is both practical and mathematically leading to a challenging problem. In this paper we consider this problem.

In [1] an approximate model was introduced that proved analytically tractable but did not lead to good agreement with simulation results. Nevertheless it represented an attempt to capture the interdependence between the nodes, contrary to the often assumed practice of considering them statistically independent, and formed the basis for similar approximate analyses in related problems [2,3]. Here we propose a

refinement of the model presented in [1] which tracks closer the interaction between the nodes and thus leads to the expectation of better agreement with the actual system. This expectation is confirmed by comparison of the analytical results to those of a simulation that was carried out only for a small number of nodes (two and three, respectively).

The precise modeling of the system we consider is straightforward in terms of a finite-dimensional, infinite, discrete random walk with appropriate boundaries. It is in fact the presence of the boundaries that causes complications and makes the analysis difficult [1,4]. Even approximate models have proven quite difficult to analyze [5-7]. The theoretical basis for establishing this as an interesting analytical problem can be found in [8], where a closely related problem of two coupled processors was considered and solved exactly. In [9-10] other approximate analysis techniques were proposed and met with limited success in terms of predicting the simulation results. In these same papers, as well as in [11], the related problem of system stability was also considered. In [12] and in [13] an idea of stochastic system domination has been introduced that provides stability bounds and approximate derivation of the steady-state distribution of an ergodic Markov chain respectively. There is a very rich literature on problems that stem from this central problem of analysis of a slotted-ALOHA system with a finite number of buffered users. Thus, one more effort in trying to "discover" a good approximation, as this paper attempts to do, is perhaps justified.

2. The Problem

Consider M terminals each of which receives packets from exogenous sources according to a Bernoulli process and lines them in a queue in a buffer of infinite capacity. The arrival rate at the i th station is λ_i and the arrival processes at different stations are statistically independent. Time is slotted and it takes exactly one slot to transmit one packet, or for a packet to arrive. Thus λ_i is also the probability of an arrival at the i th station in any given slot.

The i th terminal attempts with probability p_i to transmit the head-of-the-line packet in the queue (if the latter is non-empty) through a common channel to the receiver. The usual ALOHA assumptions are made concerning success or collision. Specifically, since we are considering discrete time, we are assuming that a packet that arrives at time t joins the queue at the corresponding terminal and it is possible, if the queue is empty at that instant, that it will be transmitted at that same instant. Ternary information (success, idle, collision) becomes available to all terminals at the next instant $t+1$ and it is possible to retransmit or delete the packet at that new time depending on whether it was involved in a collision or a successful transmission.

To include several variants of the ALOHA protocol (such as immediate first transmission, delayed first transmission, etc. (see [14])) we distinguish the status of a given terminal at the beginning of a given slot into three categories, idle, active and blocked. A terminal is idle if there were no packets in its buffer at the end of the preceding slot, it is blocked if its queue is not empty and the latest attempted transmission was unsuccessful, and it is active if its queue is not empty but its most recent attempted transmission was successful. We then let

$$p_i = \begin{cases} r_i \lambda_i, & \text{if } i \text{ is idle} \\ s_i, & \text{if } i \text{ is active} \\ q_i, & \text{if } i \text{ is blocked} \end{cases}$$

For this system which is schematically shown in Fig. 1, we wish to calculate either the joint probability distribution of the queue sizes $\{N_i, i=1, \dots, M\}$ at steady state or the average values of these queue sizes (and, therefore, the average packet delays using Little's formula).

The mathematical model for this system consists of a $2M$ dimensional Markov chain the states of which are represented by

$$\bar{S} = (S_1, \dots, S_M; N_1, \dots, N_M)$$

where

S_i = status of the i th terminal (ternary variable with values = idle, active, and blocked)*

and

N_i = queue size at the i th terminal

The transition probabilities for this chain can be obtained explicitly and so can the steady state equations. However their number is infinite and, owing to the fact that the transition probabilities on the boundaries are different from the ones in the interior of the state space, traditional analysis methods (for example, in terms of moment generating functions) are inadequate.

3. The Proposed Approximate Model

The idea of simplifying the model without losing track of the interdependence between the queue sizes of different terminals, that was proposed in [1], consisted of considering the "status-state" separately from the "queue-size" state. Thus a system state was defined that consisted of the triplet (I,A,B) where I denoted the number of idle terminals, A the number of active terminals, and $B = M - (I+A)$ the number of blocked terminals. Separately, for each terminal a node state was defined consisting of the pair (N_i, S_i) where N_i denoted the queue size of the i th terminal and S_i its status.

Transitions between the states of the system state variable are not Markovian. However, in [1] they were considered Markovian with transition probabilities equal to

* we represent "idle" by 0, "active" by 1, and "blocked" by 2.

the average probabilities of transition, where the averaging took place over all values of the queue sizes. Similarly the transitions between the states of the node state variable are not Markovian. Again, in [1] they were considered Markovian with the transition probabilities calculated as averages of the true transition probabilities over all values of the system status states. The resulting balance equations for both systems were coupled and could be solved numerically. As mentioned earlier, agreement with simulation results proved to be unsatisfactory and this was proved by a simulation study done at ETH [15].

In trying to determine the reason for the limited success of the model proposed in [1], we observed that the model failed to track the status of the M terminals one-by-one. Instead it considered only the numbers of active, idle, and blocked terminals respectively.

In this paper we formulate a model that again separates status-states from queue-size-states, in the spirit of the model in [1], but expands the state space of the system status variables in order to track every terminal's status separately. Again, however, the model is approximate in that the transition probabilities between the states of each of the two chains are the averages of the true transition probabilities from the original 2M-dimensional Markov chains.

Before we proceed with the mathematical details we would like to justify the value of this approximation a priori. It is clear that in a slotted ALOHA system the probability of success for an attempted transmission depends exclusively on the status of the other terminals. Thus for the i-th terminal the probability of success is given by

$$P(i) = p_i \prod_{j \neq i} (1-p_j) = p_i \prod_{\substack{j \neq i \\ j \in S_I}} (1-r_j \lambda_j) \prod_{\substack{j \neq i \\ j \in S_A}} (1-s_j) \prod_{\substack{j \neq i \\ j \in S_B}} (1-q_j), \quad (1)$$

where S_I , S_A , S_B represent the sets of the idle, active, and blocked nodes respectively. If the system is "symmetric", that is the quantities r_j, s_j, q_j, λ_j do not

depend on j , the success probability becomes a function only of the numbers of terminals in the sets S_I , S_A , and S_B . This observation led to the model developed in [1]. However, transitions between the states of a process that consists of these numbers only, fails completely to "remember" the status of a given terminal in going from slot to slot. Thus, although the success probability might still depend on the numbers only, the transitions "average-out" the effect of the tendency of a given terminal to undergo, or postpone, a change in its own status. Of course, in addition, if the system is not symmetric, it is necessary to track the status of each terminal separately because each terminal contributes differently to the success probability depending on its status.

Thus we shall consider a status variable \bar{S} consisting of M ternary variables, S_1, S_2, \dots, S_M , each of which indicates the status of the corresponding terminal. Separately, we shall consider M queue length variables, each representing the status and queue length of a given terminal independently of the status or queue lengths of the other terminals. We shall consider these variables to evolve as independent Markov chains (they are, in fact, neither Markov, nor independent). The transition probabilities of each chain, we shall see, will depend on the steady-state probabilities of the other chains and thus will take into account a parametric (but not statistical) coupling between them, even though the model is not exact.

3.1 The System-Status Markov Chain

Let $\bar{S} = (S_1, \dots, S_M)$ be the M -dimensional status variable, where

$$S_i = \begin{cases} 0, & \text{if } i \text{ is idle} \\ 1, & \text{if } i \text{ is active} \\ 2, & \text{if } i \text{ is blocked} \end{cases}$$

Let $P(\bar{S})$ be the joint, steady-state probability distribution of this random vector. In Fig. 2 the exact states for $M=2$ are shown. (Note that the state (1,1) is not achievable since it is impossible for two nodes to have had successful

transmissions in the same slot). The total number of states achievable by this vector is easily calculated to be

$$\sum_{n=0}^M \binom{M}{n} + M \sum_{n=0}^{M-1} \binom{M-1}{n} = \sum_{n=0}^M \binom{M}{n} n = 2^{M-1}(M+2)$$

where n indicates the number of blocked nodes, and where the fact that not more than one node can be active is taken into account.

It is assumed that the evolution of \bar{S} is Markovian with probabilities that are suitably estimated. Their calculation is displayed in Appendix 1, where we assume $s_1 = r_1 = 1$. It is important to note that in that calculation two quantities that characterize the node-chain (not yet described) are required. These are calculated in Appendix 2 and are the following:

$$P_1(1|1) \triangleq \Pr[\text{queue size} > 1 \mid \text{node } i \text{ is active}]$$

and

$$P_1(0|2) \triangleq \Pr[\text{queue size} = 1 \mid \text{node } i \text{ is blocked}]^*$$

Thus the state equations for this chain (and therefore the solution $P(\bar{S})$) depend on the above quantities. As we shall see, the above quantities, as obtained in Appendix 2, depend in turn on $P(\bar{S})$. Thus all state equations for both chains must be solved simultaneously.

3.2 The Queue-Length Markov Chain

Let N_i be the total number of packets (the queue-length) at terminal i and let T_i be the indicator of blocked or unblocked status, i.e.

* note that the queue size is considered to include the packets waiting in the queue to be served plus the packet being served; that is, it is equal to the total number of packets residing at the terminal.

$$T_i = \begin{cases} 0, & \text{if } i \text{ is blocked} \\ 1, & \text{if } i \text{ is unblocked (i.e. active or idle)} \end{cases}$$

The pair (T_i, N_i) constitutes the state of the terminal and let $\pi(T_i, N_i)$ denote its steady state probability. This state is assumed to evolve as a Markov chain. Of special interest in our calculations, as shown in Appendix 2, are the quantities $\pi(0,0)$, $\pi(1,0)$, $\pi(1,1)$ and the conditional moment generating functions $G_0^i(z)$ and $G_1^i(z)$, where

$$G_{T_i}^i(z) = \sum_{N_i=0}^{\infty} \pi(T_i, N_i) z^{N_i}, \quad T_i = 0,1$$

These quantities, as well as the state transition probabilities that lead to their determination, can be calculated in terms of the following "average" success probabilities:

$$P_B(i) = \Pr[\text{success} | \text{node } i \text{ is blocked}] \quad (2)$$

$$P_A(i) = \Pr[\text{success} | \text{node } i \text{ is active}] \quad (3)$$

$$P_I(i) = \Pr[\text{success} | \text{node } i \text{ is idle}] \quad (4)$$

where the averaging is performed over the status of the other nodes (and for which the state probabilities $P(\bar{S})$ of the status states are required, thereby leading to the coupling of the two sets of equations).

In fact it is shown in the appendix that, for the case of $r_i = s_i = 1$ and $q_i = p_i$ (case of immediate first transmission), we have

$$\pi(0,0) = \frac{\lambda_i \bar{P}_I(i)}{\lambda_i P_A(i) + \lambda_i P_B(i)} \pi(1,0) \quad (5)$$

$$\pi(1,0) = \frac{\bar{\lambda}_i P_B(i) - \lambda_i \bar{P}_A(i)}{\bar{\lambda}_i P_B(i) - \lambda_i (P_I(i) - P_A(i))} \quad (6)$$

$$\pi(1,1) = \frac{\lambda_1}{\bar{\lambda}_1} \pi(0,0) \quad (7)$$

$$G_0^1(1) = \frac{\lambda_1 \bar{\lambda}_1 \bar{P}_I(1)}{\bar{\lambda}_1 P_B(1) - \lambda_1 (P_B(1) - P_A(1))} \quad (8)$$

$$G_1^1(1) = \lambda_1 + \bar{\lambda}_1 \frac{\bar{\lambda}_1 P_B(1) - \lambda_1 \bar{P}_A(1)}{\bar{\lambda}_1 P_B(1) - \lambda_1 (P_I(1) - P_A(1))} \quad (9)$$

where $\bar{\lambda} = 1 - \lambda$ and $\bar{P} = 1 - P$.

Similar expressions can be obtained for the much studied case of delayed first transmission (i.e. $r_i = s_i = q_i = p_i$).

4. The Average Success Probabilities

Central to the calculations in the appendices is the knowledge of the average success probabilities as defined above in Eqs. (2-4). These are easily expressed in terms of the system state probabilities $P(S_1, \dots, S_M)$ and by making use of the simple ALOHA logic expressed in Eq. (1), as follows:

1) for blocked node i

$$P_B(i) = \Pr(\text{node } i \text{ success} | \text{node } i \text{ is blocked}) \\ = \frac{\Pr(\text{node } i \text{ success and node } i \text{ is blocked})}{\Pr(\text{node } i \text{ is blocked})}$$

where

$$P(\text{node } i \text{ success and node } i \text{ is blocked}) = p_i \sum_{\substack{S_1=2 \\ S_j \neq 1 \\ (j \neq i)}} \prod_{j \neq i} (\bar{P}_j^{\delta_{2S_j}} \bar{\lambda}_j^{\delta_{0S_j}}) P(S_1, \dots, S_M)$$

with the summation ranging over all state values for which node i is blocked and no other node is active. The exponents δ are Kronecker coefficients. Furthermore,

$$P(\text{node } i \text{ blocked}) = \sum_{S_i=2} P(S_1, \dots, S_i, \dots, S_M)$$

2) for active node i

$$P_A(i) = P(\text{node } i \text{ success} | \text{node } i \text{ is active})$$

$$= \frac{P(\text{node } i \text{ success and node } i \text{ is active})}{P(\text{node } i \text{ is active})}$$

where

$$P(\text{node } i \text{ success and node } i \text{ is active}) = \sum_{\substack{S_i=1 \\ S_j \neq 1 \\ (j \neq i)}} \prod_{j \neq i} (\bar{p}_j^{\delta_{2S_j}} \lambda_j^{\delta_{0S_j}}) P(S_1, \dots, S_M)$$

and

$$P(\text{node } i \text{ is active}) = \sum_{S_i=1} P(S_1, \dots, S_i, \dots, S_M)$$

3) for idle node i

$$P_I(i) = P(\text{node } i \text{ success} | \text{node } i \text{ is idle})$$

$$= \frac{P(\text{node } i \text{ success and node } i \text{ is idle})}{P(\text{node } i \text{ is idle})}$$

where

$$P(\text{node } i \text{ success and node } i \text{ is idle}) = \lambda_i \sum_{\substack{S_i=0 \\ S_j \neq 1 \\ (j \neq i)}} \prod_{j \neq i} (\bar{p}_j^{\delta_{2S_j}} \lambda_j^{\delta_{0S_j}}) \cdot P(S_1, \dots, S_M)$$

and

$$P(\text{node } i \text{ is idle}) = \sum_{S_i=0} P(S_1, \dots, S_i, \dots, S_M)$$

5. The Delay

The total average delay incurred by a packet from the moment of its arrival to the terminal until the time of its successful transmission consists of three components, waiting time in queue, $W_q(i)$, "service" time from the instant it arrives at the head-of-the-line position in the buffer until it is successfully transmitted, $W_s(i)$, and the actual transmission time (which we take to be equal to one slot for "local" environments).

The component $W_s(i)$ is approximated by $\frac{G_0(i)}{P_B(i)}$ which is, equivalently, given by $\frac{\text{Pr}(i \text{ is blocked})}{P_B(i)}$. The component $W_q(i)$ is obtained from Little's result by

$$W_q(i) = \frac{L_i}{\lambda_i}$$

where L_i is the average queue length (without considering the blocked head-of-the-line packet as part of the queue). This quantity is calculated in Appendix 2 and is given by

$$L_i = \frac{\lambda_i^2 \bar{\lambda}_i \bar{P}_I(i)}{(\bar{\lambda}_i P_B(i) - \lambda_i \bar{P}_A(i))(\bar{\lambda}_i P_B(i) - \lambda_i (P_I(i) - P_A(i)))} \quad (10)$$

Thus, for terminal i , the delay D_i is given by

$$D_i = 1 + \frac{L_i}{\lambda_i} + \frac{G_0(i)}{P_B(i)}$$

and the total weighted average system delay D is given by

$$D = \frac{\sum_{i=1}^M D_i \lambda_i}{\sum_{i=1}^M \lambda_i}$$

6. The Solution Algorithm and Numerical Results

As explained in the preceding sections the state equations that must be solved

to yield the system state probabilities $P(S_1, S_2, \dots, S_M)$ and the state equations for the node state probabilities $\pi(T_i, N_i)$ are coupled and must be solved simultaneously. The coupling, as shown in the appendixes, occurs in terms of the boundary condition probabilities $P_i(1|1)$ and $P_i(0|2)$ as well as the average success probabilities $P_B(i)$, $P_I(i)$, $P_A(i)$. Given the values of these auxiliary quantities each system of equations can be solved separately. Thus due to the non-linear nature of the coupling, it is natural to proceed iteratively, as shown in Figure 3. The iterative method used is identical to the one used in [1]. Arbitrary values for one set of state probabilities are chosen and used to solve for the other set. Then the values obtained for the second set are used to recalculate those of the first set, and so on. Conditions for convergence are identical as in [1]. Of course it must be assumed that the values of the arrival rates λ_i are such that the system of the queues is stable (ergodic). As conditions for ergodicity are not known except for the case of $M=2$ [9-13], we used rather small values for the λ_i 's to avoid running into the unstable region in which the numerical results would be meaningless. In fact, the region near saturation is expected to show poor agreement with simulation exactly because the stability boundary (which is not precisely known) may be crossed in a simulation.

The numerical results for the case of $M=2$ with $\lambda_1 = \lambda_2$ and $p_1 = p_2$ are shown in Fig. 4 and with $\lambda_1 = \lambda_2$, $p_1 \neq p_2$ in Fig. 5. Numerically optimizing over the values of the p_i 's we find that in the non-symmetric loading case the delay performance is consistently superior over all throughput values to that of the best symmetric case, see Fig. 6. In fact the optimum non-symmetric case requires that one of the two p_i 's be equal to one. The other p_i -value can be computed and varies with λ . The implication is that by favoring one of the two users the average delay is improved. Thus the gains achieved by one user outweigh the losses incurred by the other. This observation may be of value in the design of access protocols if it is explained and confirmed by rigorous theoretical justification.

To evaluate this approximate model a Monte-Carlo simulation was run for a 2-node and a 3-node system with various values of retransmission probabilities and arrival rates. The comparison to the computational results is shown in Figures 7 and 8 respectively, for non-symmetric loading cases.* The average delay for each terminal is plotted separately. The arrival rates are equal for all terminals.

In Fig. 9 we compare the approximate results from our model to the analytical results of [4]. The case of two users with symmetric loading ($p_1=p_2$) is the only one that has been solved exactly and thus such a comparison is necessary. We find excellent agreement, with difference between the two sets of results bounded by 7.5%. Equally good agreement is found between optimal delays for the approximate and analytical cases for the symmetric two-user system as shown in Fig. 10.

7. Conclusion

In this paper a variation of an approximate model for the delay analysis of a slotted-ALOHA system with a finite number of buffered terminals was proposed and analyzed. Limited performance evaluation was carried out for small numbers of terminals in terms of comparison of the results to the analytically obtained ones (whenever exact analysis is available) and to those obtained by simulation. Agreement proved to be very good. Not having evaluated the model for greater values of numbers of terminals we can only be moderately confident in its predictive capability. Our confidence, however, is backed by the arguments provided about the structural nature of the model that served also as our primary source of motivation in proposing it. We believe it may prove to be a useful and usable tool in evaluating performance of several protocols (such as CSMA) that rely on contention among a finite number of terminals that maintain packet queues.

* the little "square" and "triangle" marks on the curves do not represent the points on the basis of which the curves were drawn but rather serve to identify the curves.

REFERENCES

- [1] Saadawi, T.N., and Ephremides, A., "Analysis, Stability, and Optimization of Slotted ALOHA with a Finite Number of Buffered Users," IEEE Trans. on Automatic Control, Vol. AC-26, No. 3, pp. 680-689, June 1981.
- [2] J. Silvester, "An Approximate Model for the Throughput/Delay Performance of Multi-Hop Broadcast Networks: Slotted ALOHA", preprint.
- [3] H. Takagi, L. Kleinrock, "Mean Packet Delay in a Buffered Two-User CSMA/CD System", IEEE Trans. on Communications, p. 1136, October 1985.
- [4] Sidi, M. and Segall, A., "Two Interfering Queues in Packet-Radio Networks," IEEE Trans. on Communications, Vol. 31, No. 1, pp. 123-129, January 1983.
- [5] Kleinrock, L. and Yemini, Y., "Interfering Queueing Processes in Packet-Switched Broadcast Communication," IFIP Congress, Tokyo, 1980.
- [6] Tobagi, F.A. and Kleinrock, L., "On the Analysis and Simulation of Buffered Packet Radio System," Proceeding of the Ninth Hawaii Int. Conf. on System Science, Honolulu, Hawaii, Jan., 1976, pp. 42-45.
- [7] Ephremides, A., "Analysis of Protocols of Multiple Access," Lecture Notes on Modeling and Performance Evaluation, Springer Verlag, Proceeding of INRIA Symposium, Jan. 1983.
- [8] Fayolle, G. and Iasnogorodski, R., "Two Coupled Processors: The reduction to a Riemann-Hilbert Problem", Wahrscheinlichkeits Theorie, pp. 1-27, 1979.
- [9] Szpankowski, W., "A Multiqueue Problem: Bounds and Approximates", Performance of Computer-Communication System, (H. Rubin, W. Bux, editors), IFIP, 1984.
- [10] Szpankowski, W., "Performance Evaluation of a Protocol for Multiaccess System", Proc. Performance '83, pp. 337-395, College Park, 1983.
- [11] B. Tsybakov, W. Mikhailov, "Ergodicity of Slotted ALOHA System", Problems of Information Transmission, Vol. 15, No. 4, pp. 73-87, 1979.

- [12] R. Rao, A. Ephremides, "Application of Countable Markov Chains Theory to the Transient and Asymptotic Behavior of Multiple Access Protocols", Proc. of 23rd Conference on Decision and Control, p. 1158, Las Vegas, Nevada, December 1984.
- [13] T. Nakasis, A. Ephremides, "A Numerical Approach to the Analysis of Interacting Queues", Proc. of ICC, June 1986, Toronto, Canada.
- [14] F. Tobagi, "Analysis of a Two-Hop Centralized Packet Radio Network", IEEE Trans. on Communications, February 1980.
- [15] R. Rueppel, Private Communication, 1983.

APPENDIX 1

TRANSITION PROBABILITIES OF SYSTEM STATUS CHAIN

In this Appendix we calculate the transition probabilities of the system status chain as discussed in section 3.1. We assume that the quantities s_i and r_i are equal to one; that is, a packet gets immediately transmitted when the terminal is idle or active. The same calculations can be easily carried out when this is not the case. Also note that \bar{p} and $\bar{\lambda}$ stand for $1-p$ and $1-\lambda$ respectively.

Since the aim is to develop the steady state distribution for the system status chain, we need to calculate the transition probabilities. These calculations reduce to considering a small number of cases, based on the change in the number of active nodes, thus we classify the transitions into four types as follows:

1) The number of active nodes transits from 0 to 1

An idle node cannot transit into active status, so the only possibility for such a transition is one involving a blocked node, say node j , which becomes active, while the other blocked nodes do not attempt to retransmit and all idle nodes receive no packets. The probability of such a transition is expressed by:

$$\begin{aligned}
 P(\Delta A = 1, \Delta B = -1) &= \prod_{k=1}^{M-n-1} \bar{\lambda}_k \prod_{i=1}^{n+1} \bar{p}_i \frac{p_j}{\bar{p}_j} [(1 - P_j(0|2)) + \lambda_j P_j(0|2)] \\
 &= \prod_{k=1}^{M-n-1} \bar{\lambda}_k \prod_{i=1}^{n+1} \bar{p}_i \frac{p_j}{\bar{p}_j} [1 - P_j(0|2)] \bar{\lambda}_j \quad (1.1)
 \end{aligned}$$

where ΔA and ΔB represent the changes in the numbers of active and blocked nodes and the first term in brackets is the probability that the buffer content of the blocked node j is not 0, while the second term is the probability that the buffer content of node j is 0 and a packet arrives. All other quantities involved have been defined in section 3. Note that for ease of notation the subscripts i and k are shown to vary from 1 to $n+1$ and from 1 to $M-n-1$ while it is meant that they vary over the sets of blocked and idle nodes respectively. The same notation is followed in

the sequel.

2) The number of active nodes remains 1

In this case, the status of all idle nodes and blocked nodes must be kept unchanged. The probability of such a transition is:

$$\begin{aligned}
 P(\Delta A = 0) &= \prod_{k=1}^{M-n-1} \bar{\lambda}_k \prod_{i=1}^n \bar{p}_i [(1-P_j(1|1)) + \lambda_j P_j(1|1)] \cdot p_j \\
 &= \prod_{k=1}^{M-n-1} \bar{\lambda}_k \prod_{i=1}^n \bar{p}_i [1-P_j(1|1)\bar{\lambda}_j] p_j
 \end{aligned} \tag{1.2}$$

where the first term in the brackets is the probability that the buffer content of the active node, node j , is greater than one and the second term is the probability that the buffer content is one while one packet arrives.

3) The number of active nodes transits from 1 to 0

We subdivide this sort of transition into three sub-types. The first sub-type is that the active node turns to idle. The probability of such a transition is given by:

$$P(\Delta A = -1, \Delta I = 1) = \prod_{k=1}^{M-n-1} \bar{\lambda}_k \prod_{i=1}^n \bar{p}_i [1-P_j(1|1)] \bar{\lambda}_j p_j \tag{1.3}$$

The second sub-type is that the active node packet collides with packets from blocked node(s) and becomes blocked. The probability of the transition is:

$$P(\Delta A = -1, \Delta B = 1) = \prod_{k=1}^{M-n} \bar{\lambda}_k (1 - \prod_{i=1}^{n-1} \bar{p}_i) \cdot p_j \tag{1.4}$$

The third sub-type is that the active node collides with $q-1$ idle nodes, which results in the active node and the $q-1$ idle nodes turning to blocked. The probability is:

$$P(\Delta A = -1, \Delta I = -(q-1), \Delta B = q) = \prod_{k_1=1}^{q-1} \lambda_{k_1} \prod_{k=q}^{M-n} \bar{\lambda}_k \cdot p_j \tag{1.5}$$

4) The number of active nodes remains 0

In this case there are four sub-types. The first one is that all nodes maintain their status without change. The transition probability is:

$$P(\Delta I = 0, \Delta B = 0) = \left[1 - \prod_{i=1}^n \bar{p}_i \sum_{j=1}^n \left(\frac{p_j}{\bar{p}_j} \right) \right] \prod_{k=1}^{M-n} \bar{\lambda}_k + \prod_{i=1}^n \bar{p}_i \prod_{k=1}^{M-n} \bar{\lambda}_k \sum_{k=1}^{M-n} \left(\frac{\lambda_k}{\bar{\lambda}_k} \right) + \prod_{k=1}^{M-n} \bar{\lambda}_k \left[1 - \prod_{i=1}^n \bar{p}_i \left(\sum_{j=1}^n \left(\frac{p_j}{\bar{p}_j} \right) - \sum_{k=1}^{M-n} \left(\frac{\lambda_k}{\bar{\lambda}_k} \right) \right) \right] \quad (1.6)$$

where the first term is the probability that no packet arrives at the idle nodes while no blocked node, or at least two blocked nodes, transmit, and the second term is the probability that no blocked node attempts to transmit while only one of the idle nodes receives an arriving packet.

The second sub-type is that one of the blocked nodes, say node j , becomes an idle node. The transition probability is:

$$P(\Delta I = 1, \Delta B = -1) = \prod_{k=1}^{M-n-1} \bar{\lambda}_k \prod_{i=1}^{n+1} \bar{p}_i \left[\bar{\lambda}_j \frac{p_j}{\bar{p}_j} P_j(0|2) \right] \quad (1.7)$$

where the quantity in the brackets is the probability that the blocked node attempts to transmit while its buffer content is 0 and no packet arrives at the node.

The third one is that only one of the idle nodes, say node j , becomes a blocked node. The probability is:

$$P(\Delta I = -1, \Delta B = 1) = \prod_{k=1}^{M-n-1} \bar{\lambda}_k \frac{\lambda_j}{\bar{\lambda}_j} \left(1 - \prod_{i=1}^{n-1} \bar{p}_i \right) \quad (1.8)$$

The fourth one is that q ($q > 2$) of the idle nodes become blocked. The transition probability is:

$$P(\Delta I = -1, \Delta B = 1) = \prod_{j=1}^q \left(\frac{\lambda_j}{\bar{\lambda}_j} \right) \prod_{i=1}^{M-n} \bar{\lambda}_i \quad M-n > 1 \quad (1.9)$$

Based on these transition probabilities we can express explicitly the state equations for the system status state. Note that they will depend on known quantities (λ_1 's and p_1 's) and the unknown quantities $P_1(0|2)$ and $P_1(1|1)$. In the next appendix these quantities will be expressed in terms of the state probabilities of the node chain, $\pi(T_1, N_1)$.

APPENDIX 2

PROBABILITY DISTRIBUTION OF QUEUE LENGTH

In this Appendix, we prove equations (5) - (10) according to the state transition diagram of Figure 11. Here, too, we assume $s_1 = r_1 = 1$, and we denote $q_1 = p_1$. The steady state equations for node 1 are as follows:

$$\begin{aligned} \pi(0,N) = & \bar{\lambda}_1 \bar{P}_B(i) \pi(0,N) + \bar{\lambda}_1 \bar{P}_A(i) \pi(1,N+1) + \lambda_1 \bar{P}_A(i) \pi(1,N) \\ & + \lambda_1 \bar{P}_B(i) \pi(0,N-1), \quad N > 0 \end{aligned} \quad (2.1)$$

$$\begin{aligned} \pi(1,N) = & \lambda_1 P_A(i) \pi(1,N) + \bar{\lambda}_1 P_B(i) \pi(0,N) + \lambda_1 P_B(i) \pi(0,N-1) \\ & + \bar{\lambda}_1 P_A(i) \pi(1,N+1), \quad N > 0 \end{aligned} \quad (2.2)$$

$$\pi(0,0) = \bar{\lambda}_1 \bar{P}_B(i) \pi(0,0) + \bar{\lambda}_1 \bar{P}_A(i) \pi(1,1) + \lambda_1 \bar{P}_I(i) \pi(1,0) \quad (2.3)$$

$$\pi(1,0) = (1 - \lambda_1 \bar{P}_I(i)) \pi(1,0) + \bar{\lambda}_1 P_B(i) \pi(0,0) + \bar{\lambda}_1 P_A(i) \pi(1,1) \quad (2.4)$$

From the equations of $\pi(1,0)$ and $\pi(0,0)$, we obtain the following equations after multiplication of both sides by z^N and addition:

$$\begin{aligned} & [(P_B(i) + \lambda_1 - P_B(i) \lambda_1) - \lambda_1 (1 - P_B(i)) z] G_0^1(z) = \\ & [\lambda_1 P_B(i) + \bar{\lambda}_1 \bar{P}_A(i) z^{-1}] G_1^1(z) + [\lambda_1 (P_A(i) - P_I(i)) - \bar{\lambda}_1 P_A(i) z^{-1}] \pi(1,0) \end{aligned} \quad (2.5)$$

From the equations for $\pi(1,0)$, $\pi(1,n)$, we obtain

$$\begin{aligned} & [1 - \lambda_1 \bar{P}_B(i) - \bar{\lambda}_1 P_A(i) z^{-1}] G_1^1(z) = [\bar{\lambda}_1 P_B(i) + \lambda_1 P_B(i) z] G_0^1(z) \\ & + [1 - \lambda_1 \bar{P}_I(i) - \lambda_1 + \lambda_1 \bar{P}_A(i) - \lambda_1 P_A(i) z^{-1}] \pi(1,0) \end{aligned} \quad (2.6)$$

Eq. (2.5) yields for $z = 1$

$$P_B(i) G_0^1(1) = \bar{P}_A(i) G_1^1(1) + (\lambda_1 \bar{P}_I(i) - \bar{P}_A(i)) \pi(1,0) \quad (2.7)$$

After differentiating (2.5) we obtain at $z = 1$:

$$P_B(1)G_0^1(1) + \lambda_1 \bar{P}_B(1)G_0^1(1) - \bar{P}_A(1)G_1^1(1) - \bar{\lambda}_1 \bar{P}_A(1)G_1^1(1) = -\bar{\lambda}_1 \bar{P}_A(1)\pi(1,0) \quad (2.8)$$

By differentiating (2.6), evaluating at $z = 1$, and adding to (2.8), we obtain

$$G_1^1(1) = \lambda_1 + \bar{\lambda}_1 \pi(1,0) \quad (2.9)$$

Then from (2.7), (2.9), and the fact that $G_0^1(1) + G_1^1(1) = 1$ we obtain (6), (8), (9). From the equations for $\pi(0,0)$ and $\pi(1,0)$, we obtain (5), (7). We use the generating property of G to calculate the average length L_1 , namely

$$L_1 = G_0^1(1) + G_1^1(1) \quad (2.10)$$

In order to calculate these derivatives, we use (2.8), which, after substitution from (5) to (9) for values of $\pi(0,0)$, $\pi(1,0)$, $\pi(1,1)$, $G_0^1(1)$ and $G_1^1(1)$, becomes

$$P_B(1)G_0^1(1) - P_A(1)G_1^1(1) = \frac{\bar{\lambda}_1 \lambda_1^2 \bar{P}_I(1)(P_B(1) - P_A(1))}{\bar{\lambda}_1 P_B(1) - \lambda_1 (P_I(1) - P_A(1))} \quad (2.11)$$

Also, we add (2.5) and (2.6), differentiate twice, and evaluate at $z = 1$. Thus we obtain

$$G_0^1(1) = \frac{\bar{\lambda}_1}{\lambda_1} G_1^1(1) + \frac{\bar{\lambda}_1 \lambda_1 \bar{P}_I(1)}{\bar{\lambda}_1 P_B(1) - \lambda_1 (P_I(1) - P_A(1))} \quad (2.12)$$

From (2.11), (2.12) we have

$$G_1^1(1) = \frac{\lambda_1^2 \bar{\lambda}_1 \bar{P}_I(1) [\bar{\lambda}_1 P_B(1) + \lambda_1 P_A(1)]}{(\bar{\lambda}_1 P_B(1) - \lambda_1 \bar{P}_A(1)) [\bar{\lambda}_1 P_B(1) - \lambda_1 (P_I(1) - P_A(1))]} \quad (2.13)$$

$$G_0^1(1) = \frac{\lambda_1^2 \bar{\lambda}_1 \bar{P}_I(1) [\bar{\lambda}_1 \bar{P}_B(1) + \lambda_1 \bar{P}_A(1)]}{(\bar{\lambda}_1 P_B(1) - \lambda_1 \bar{P}_A(1)) [\bar{\lambda}_1 P_B(1) - \lambda_1 (P_I(1) - P_A(1))]} \quad (2.14)$$

Thus

$$L_i = G_0^i(1) + G_1^i(1) = \frac{\lambda_i^2 \bar{\lambda}_i \bar{P}_i(1)}{(\bar{\lambda}_i P_{B_i}(1) - \lambda_i \bar{P}_{A_i}(1)) [\bar{\lambda}_i P_{B_i}(1) - \lambda_i (P_{I_i}(1) - P_{A_i}(1))]} \quad (2.15)$$

which is Eq. (10).

Finally from the definitions in section 3.1 it follows that

$$P_i(1|1) = \frac{\pi(1,1)}{G_1^i(1) - \pi(1,0)}$$

$$P_i(0|2) = \frac{\pi(0,0)}{G_0^i(1)}$$

By using (5) - (7), we prove also that

$$P_i(1|1) = P_i(0|2) \quad (2.16)$$

Thus all equations now are explicitly obtained and permit the application of the iterative algorithm shown in Fig. 3.

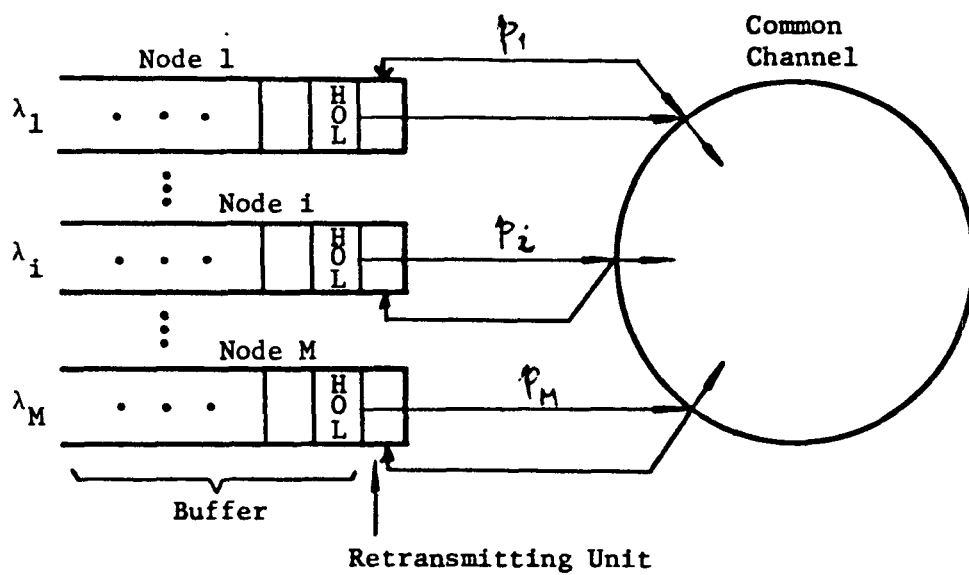

Figure 1: Model of a Slotted ALOHA System

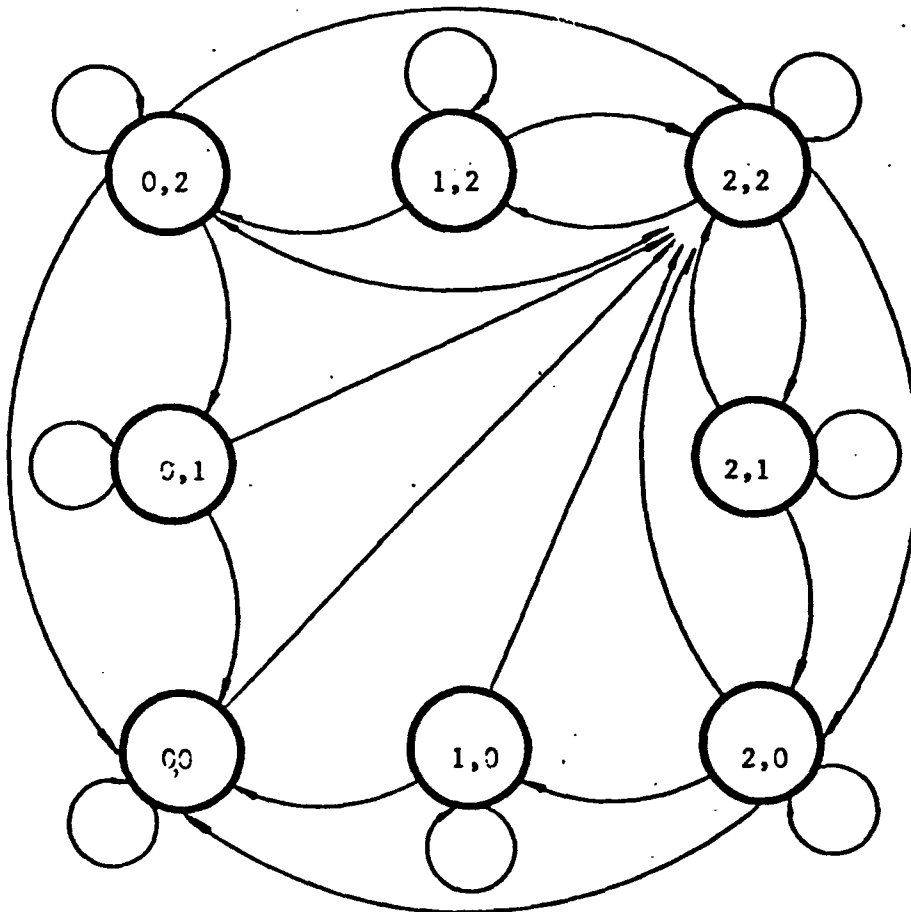

Figure 2 : System Status Markov Chain for M=2; each pair denotes the status of the two terminals; 0,1,2 stand for idle, active, and blocked respectively.

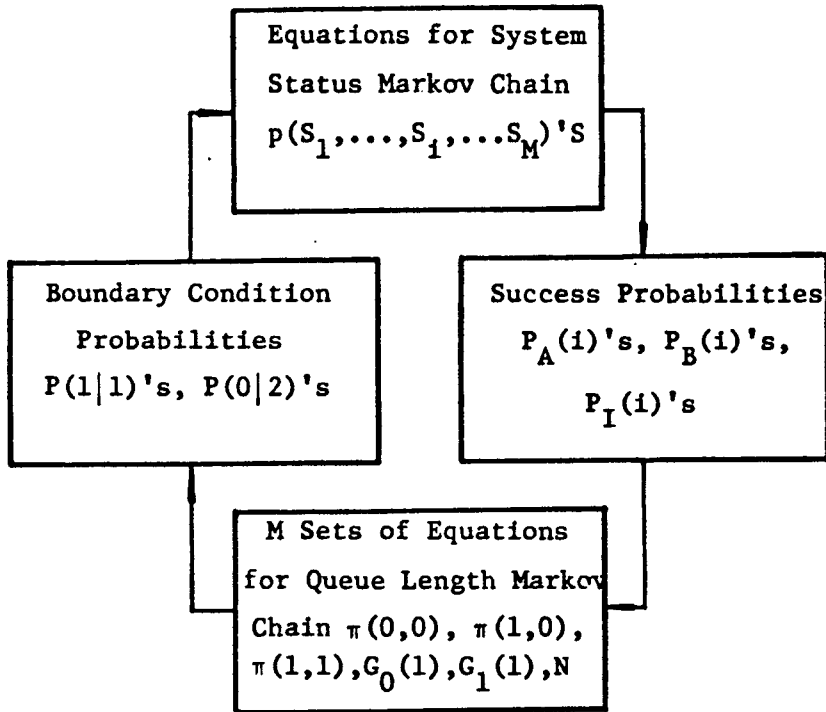

Figure 3: Iterative Algorithm for the solution of the coupled sets of equations for the state probabilities of the system chain and the queue length chains.

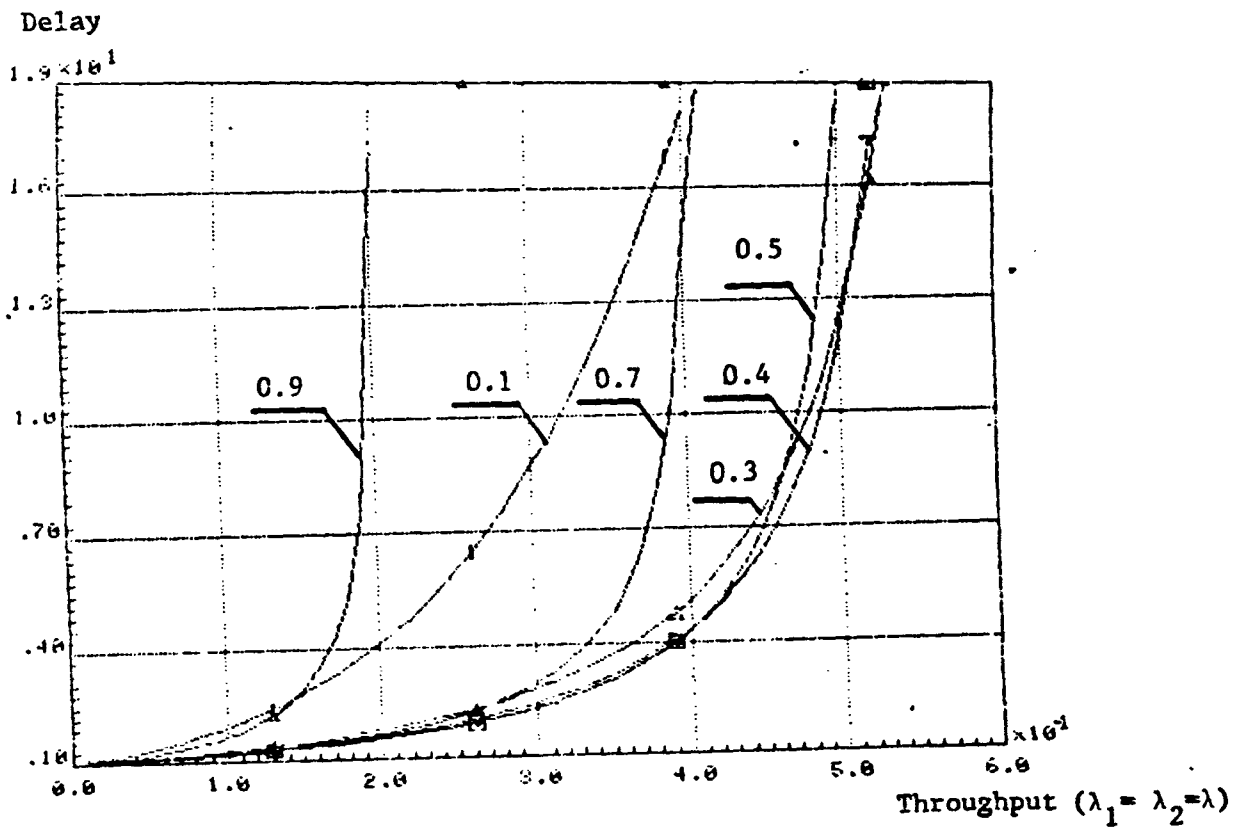

Figure 4 : System Delay vs. Throughput for Symmetric Case, $M=2$
 curves are parametrized by $p(p_1=p_2=p)$.

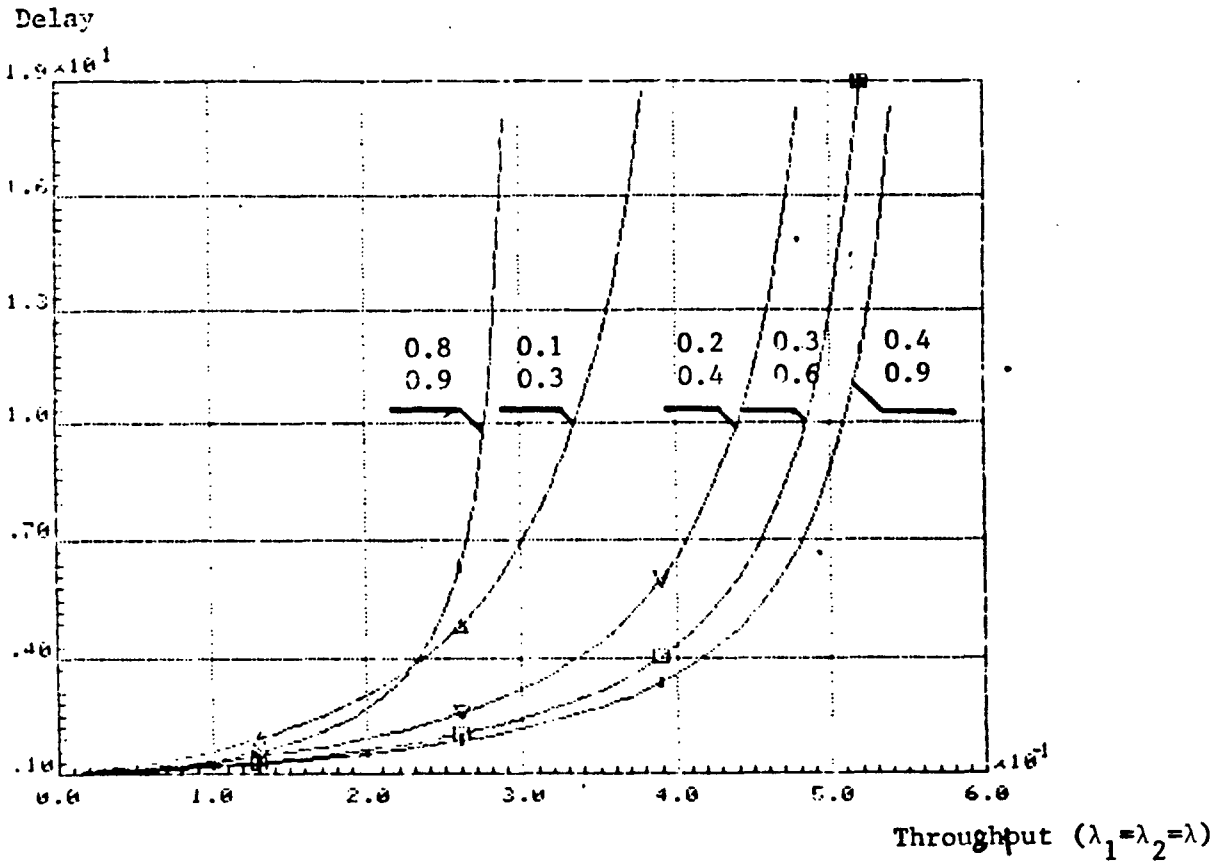

Figure 5 : Average System Delay vs. Throughput for Non-symmetric Case, $M=2$. Curves are parametrized by the pairs of values of p_1 and p_2 respectively.

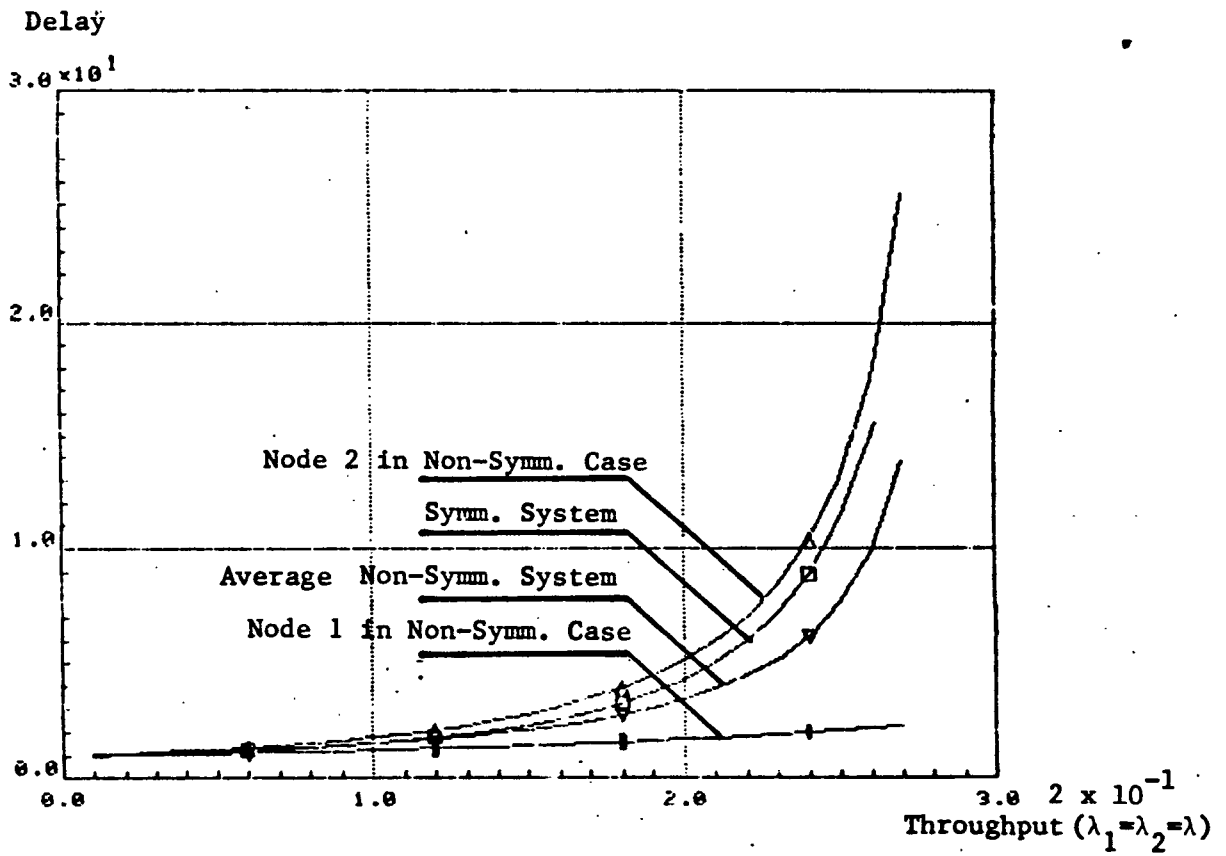

Figure 6: Optimal Delay vs. Throughput of Two Node System in Symmetric and Non-Symmetric Case.

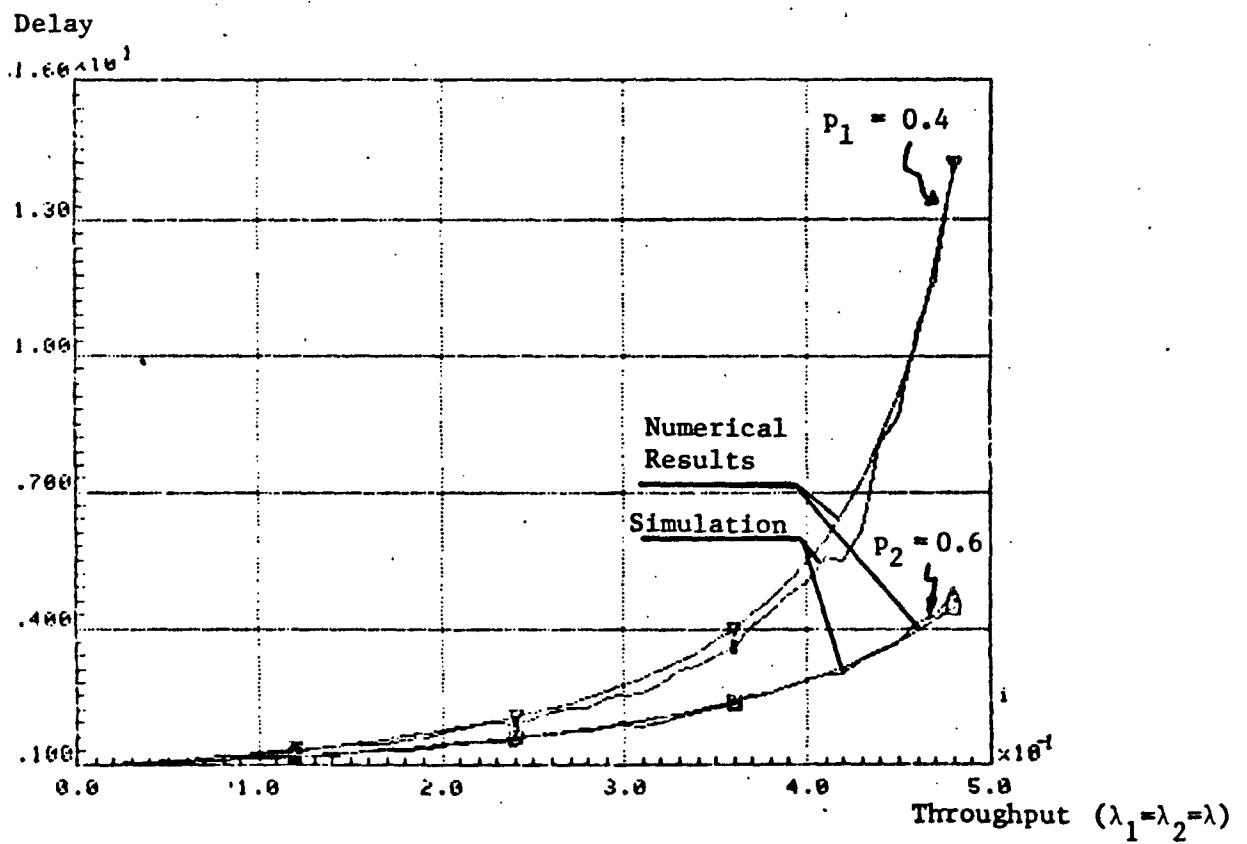

Figure 7 ; Comparison Between Numerical Results and Simulation
(M = 2)

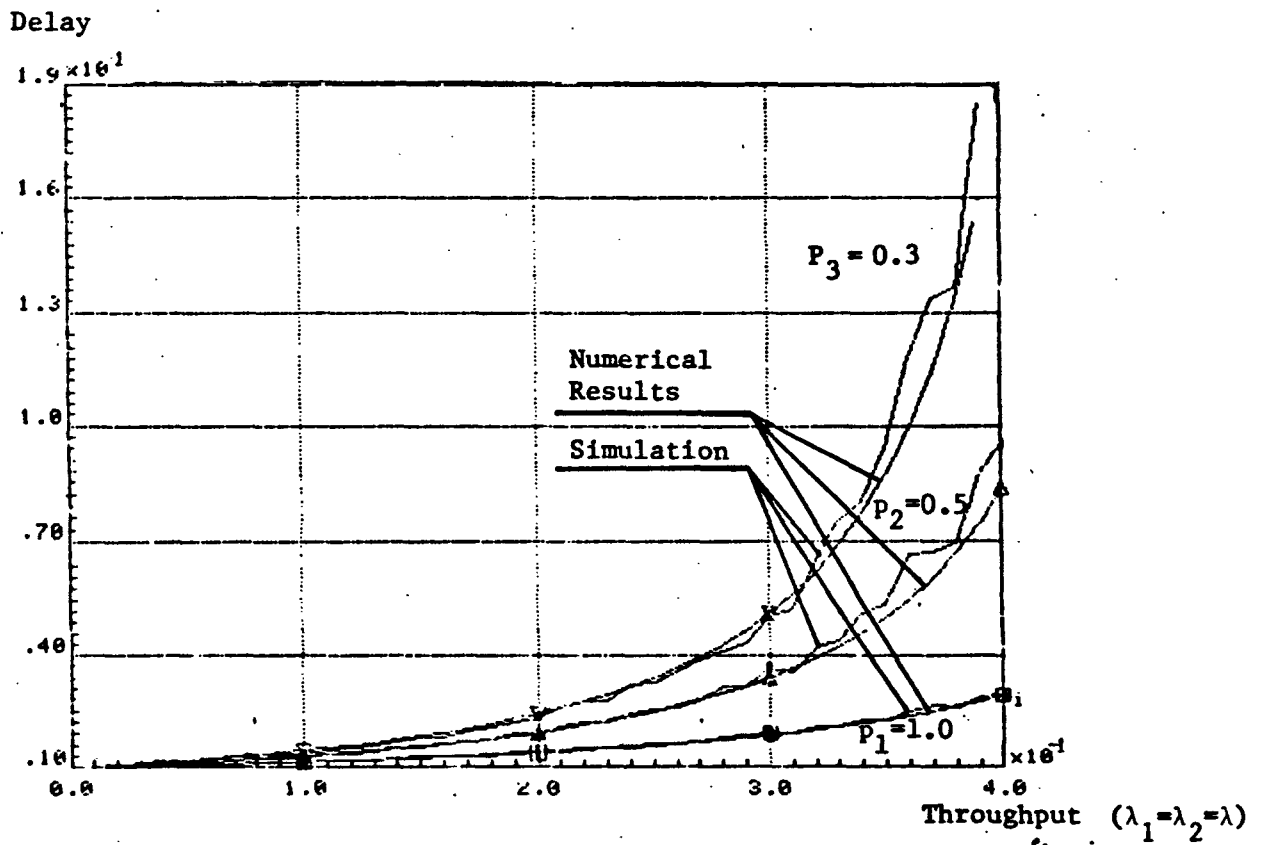

Figure 8 : Comparison Between Numerical Results and Simulation
(M = 3)

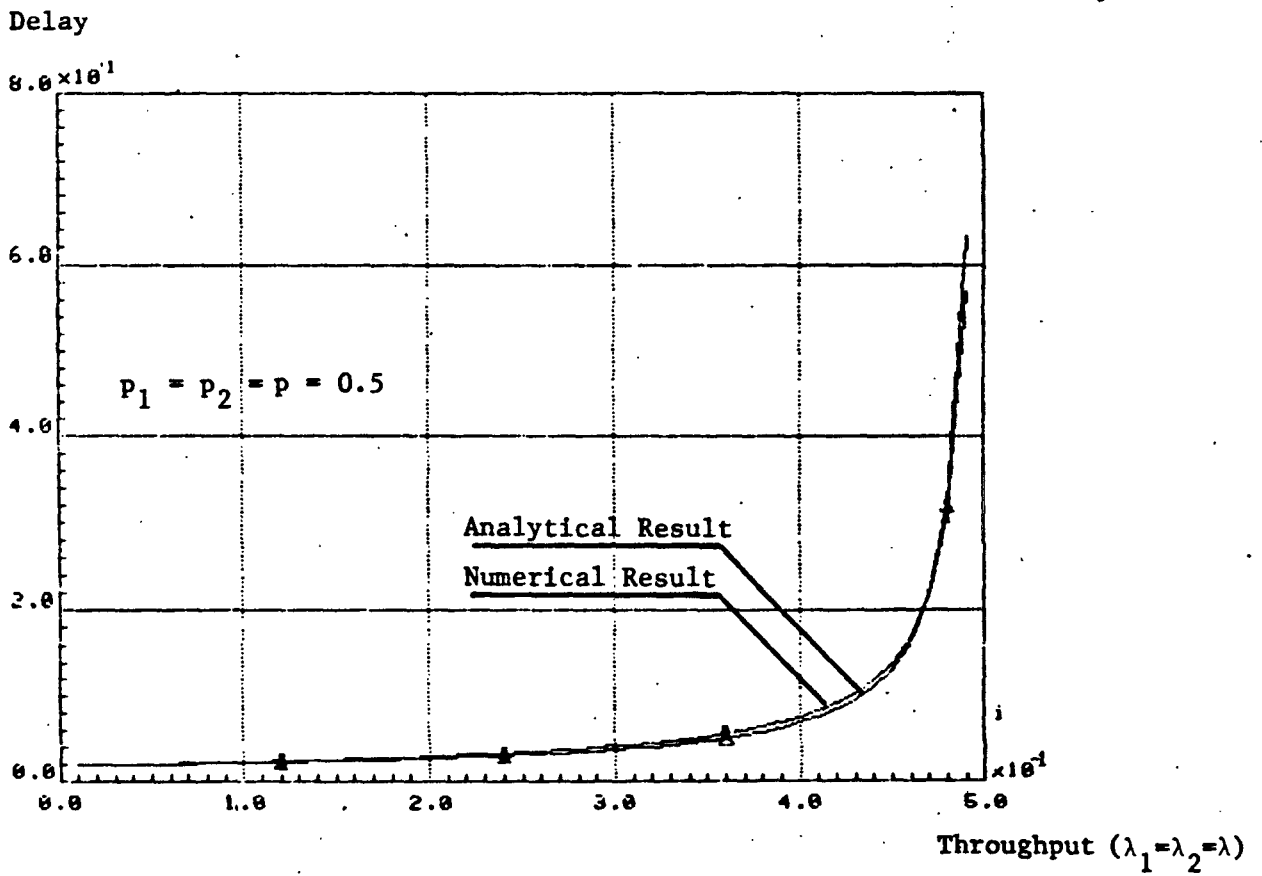

Figure 9 Delay vs. Throughput for Symmetric Case of Scheme 2 (M = 2)

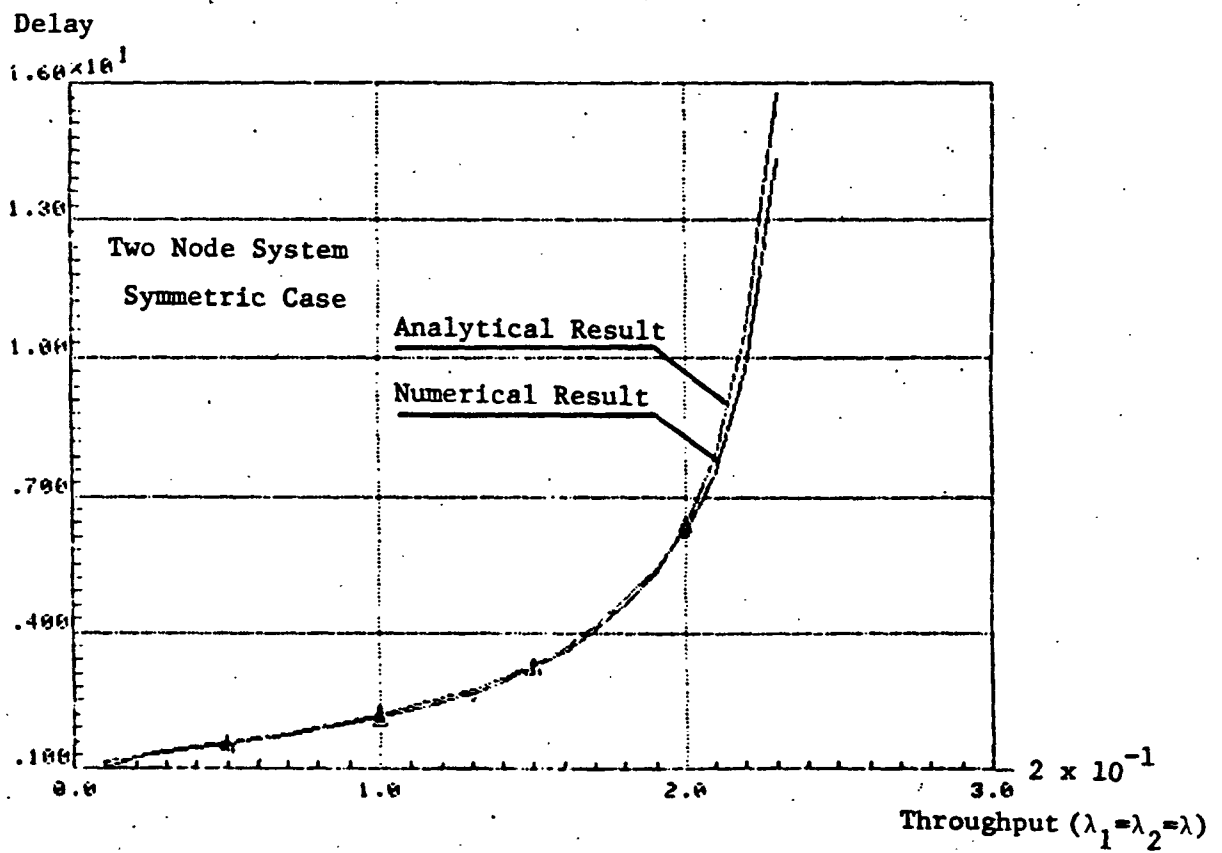

Figure 10: Comparison Between Optimal Delay vs. Throughput Between Numerical and Analytical Results

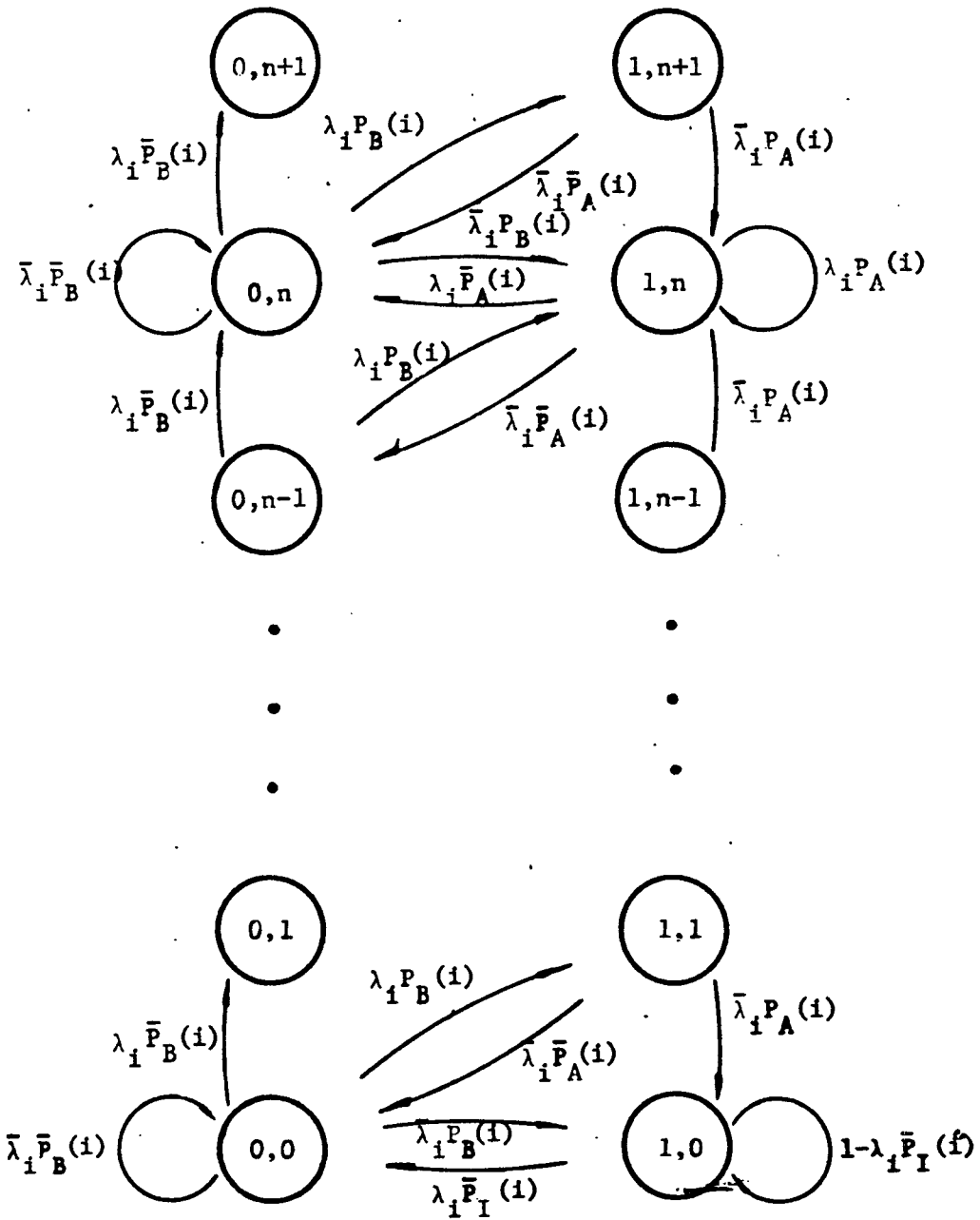

Figure 11 : Transition of Node Status and Queue Length

